

4. Turn Signal and Hazard Light System

A: WIRING DIAGRAM

1. TURN SIGNAL LIGHT AND HAZARD LIGHT

<Ref. to WI-121, SCHEMATIC, Turn Signal Light and Hazard Light System.>

B: INSPECTION

1. TURN SIGNAL SWITCH

<Ref. to LI-9, INSPECTION, Combination Switch (Light).>

2. HAZARD SWITCH

Measure the hazard switch resistance.

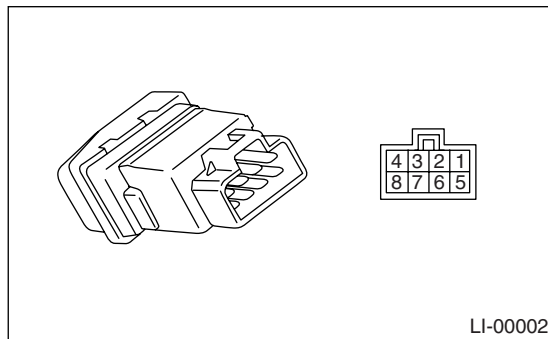

Switch position	Terminal No.	Standard
OFF	6 and 7	Less than 1 Ω
ON	1, 3 and 4	Less than 1 Ω
	7 and 8	Less than 1 Ω

3. TURN SIGNAL AND HAZARD MODULE

Connect the battery and turn signal light bulb to the module, as shown in the figure. The module is properly functioning if it blinks when power is supplied to the circuit.

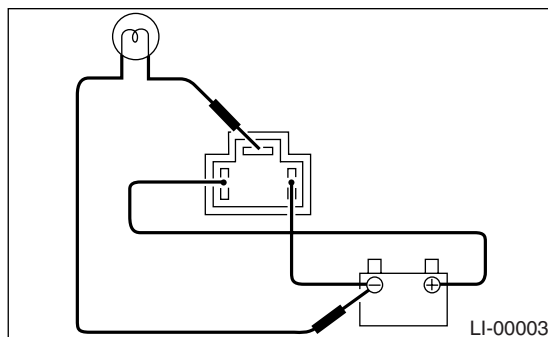

BACK-UP LIGHT SYSTEM

LIGHTING SYSTEM

5. Back-up Light System

A: WIRING DIAGRAM

1. BACK-UP LIGHT

<Ref. to WI-110, SCHEMATIC, Back-up Light System.>

B: INSPECTION

1. BACK-UP LIGHT SWITCH (MT MODEL)

Measure the back-up light switch resistance.

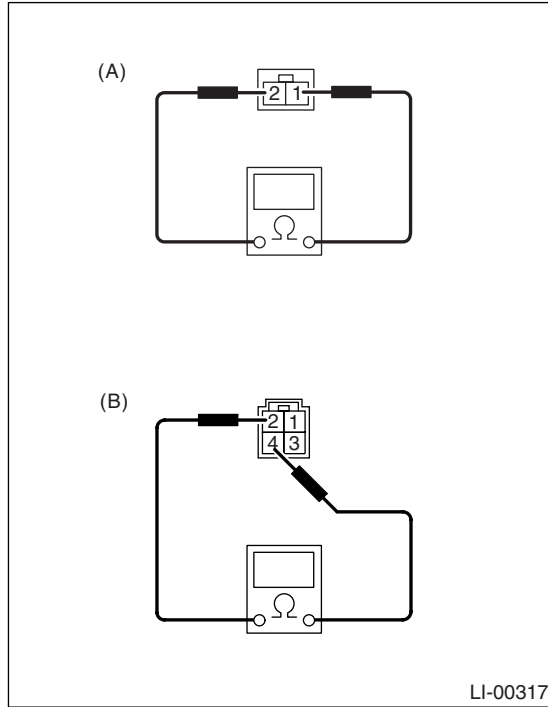

(A) Non-turbo model

(B) Turbo model

Switch position	Terminal No.	Standard
When shift lever is set in reverse position	Non-turbo model: 1 and 2 Turbo model: 2 and 4	Less than 1 Ω
Other positions		More than 1 M Ω

2. INHIBITOR SWITCH (AT MODEL)

Measure the inhibitor switch resistance.

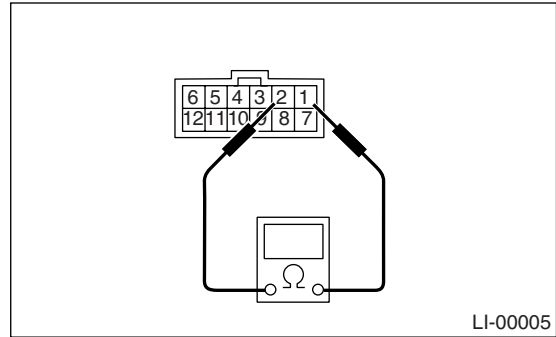

Switch position	Terminal No.	Standard
When select lever is set in "R" position	1 and 2	Less than 1 Ω
Other positions		More than 1 M Ω