

FRONT ABS WHEEL SPEED SENSOR

ABS

4. Front ABS Wheel Speed Sensor

A: REMOVAL

- 1) Disconnect the ground cable from battery.
- 2) Disconnect the front ABS wheel speed sensor connector located next to the front strut mounting house in engine compartment.
- 3) Remove the bolts which secure sensor harness to strut.

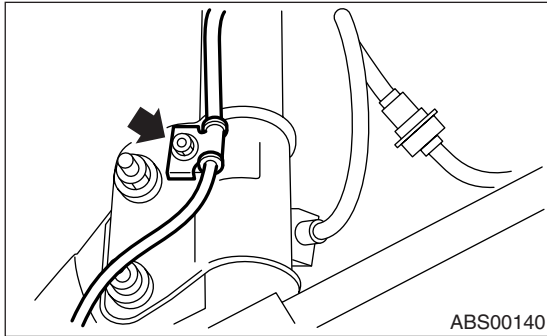

- 4) Remove the bolts which secure sensor harness to body.

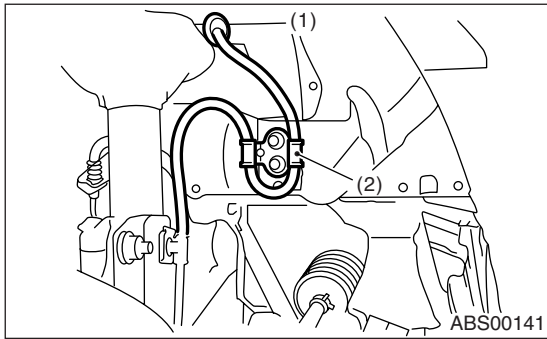

- (1) To front ABS wheel speed sensor connector
- (2) Bracket

- 5) Remove the bolts which secure front ABS wheel speed sensor to housing, and remove the front ABS wheel speed sensor.

CAUTION:

- Be careful not to damage the pole piece located at tip of the sensor and teeth faces during removal.

- Do not pull the sensor harness during removal.

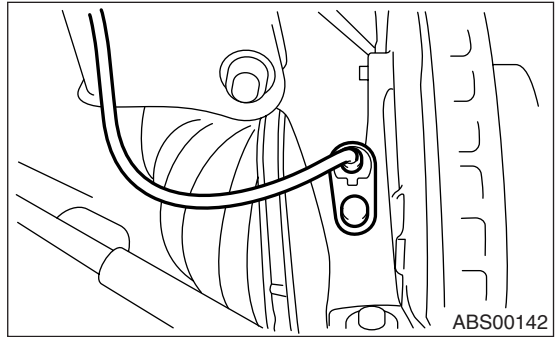

B: INSTALLATION

- 1) Temporarily install the front ABS wheel speed sensor on housing.

CAUTION:

- Be careful not to strike the ABS wheel speed sensor's pole piece against tone wheel and adjacent metal parts during installation.

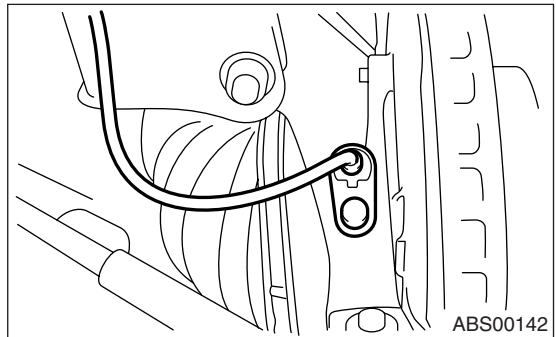

- 2) Install the front ABS wheel speed sensor on strut and wheel apron bracket.

Tightening torque:

33 N·m (3.4 kgf·m, 24.6 ft·lb)

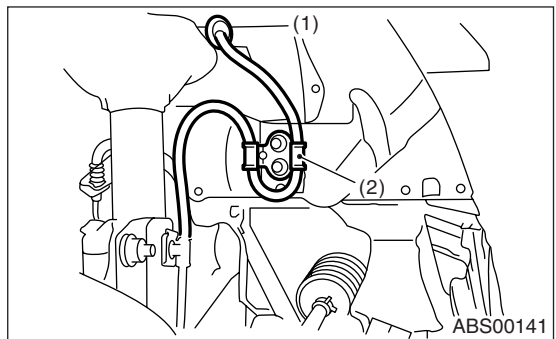

- (1) To front ABS wheel speed sensor connector
- (2) Bracket

3) Check the ABS wheel speed sensor gap. <Ref. to ABS-15, SENSOR GAP, INSPECTION, Front ABS Wheel Speed Sensor.> After standard clearance is obtained, tighten the ABS wheel speed sensor on housing to specified torque.
If the clearance is outside specification, readjust using spacer (Part No. 26755AA000).

ABS wheel speed sensor standard clearance:
0.3 — 0.8 mm (0.012 — 0.031 in)

Tightening torque:
33 N·m (3.4 kgf·m, 24.6 ft·lb)

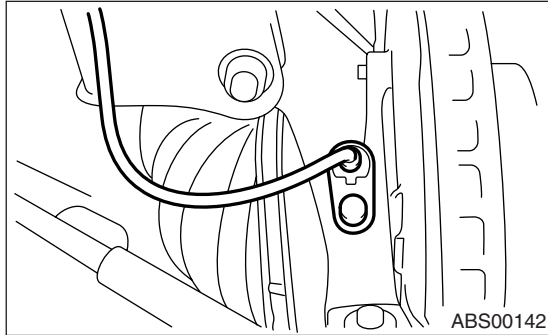

NOTE:
Check the marks on the harness and make sure that no kink exists. (RH: Light blue, LH: Brown)
4) After confirmation of the ABS wheel speed sensor clearance, connect the connector to ABS wheel speed sensor.
5) Connect the battery ground cable to battery.

C: INSPECTION

1. ABS WHEEL SPEED SENSOR

1) Check the pole piece of ABS wheel speed sensor for foreign particles or damage. If necessary, clean the pole piece or replace ABS wheel speed sensor.
2) Measure the ABS wheel speed sensor resistance.
If the resistance is outside standard value, replace the ABS wheel speed sensor with a new one.

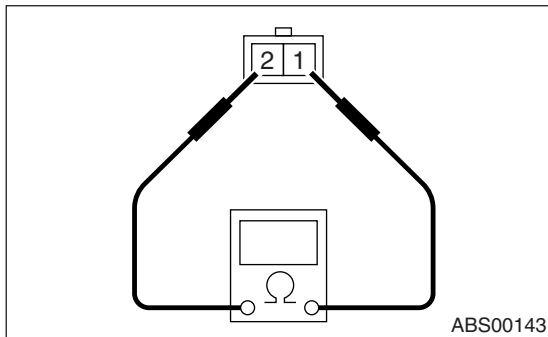

Terminal No.	Standard
1 and 2	1.25±0.25 kΩ

NOTE:
Check the ABS wheel speed sensor cable for discontinuity. If necessary, replace with a new one.

2. SENSOR GAP

1) Measure the distance “A” between ABS wheel speed sensor surface and sensor pole face.

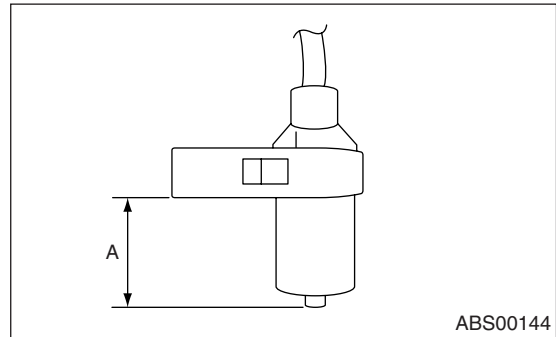

2) Measure the distance “B” between surface where the front axle housing meets the ABS wheel speed sensor and the tone wheel.

NOTE:
Measure so that the gauge touches the tone wheel teeth top.

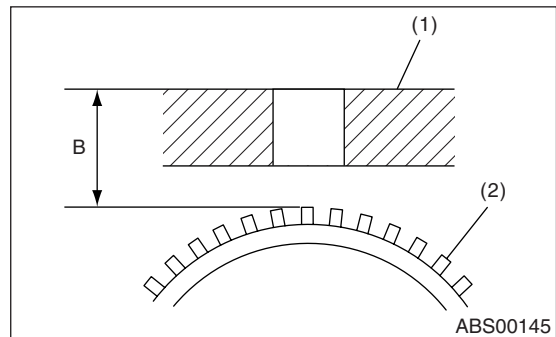

- (1) Axle housing
- (2) Tone wheel

3) Find the gap between the ABS wheel speed sensor pole piece and the surface of the tone wheel teeth by putting the measured values in the formula below and calculating.

$$\text{ABS wheel speed sensor clearance} = B - A$$

ABS wheel speed sensor standard clearance:
0.3 — 0.8 mm (0.012 — 0.031 in)

NOTE:
If the clearance is outside specification, readjust using spacer (Part No. 26755AA000).

FRONT ABS WHEEL SPEED SENSOR

ABS

3. OUTPUT VOLTAGE

Output voltage can be checked by the following method. Install the resistor and condenser, then rotate the wheel about 2.75 km/h (2 MPH) or equivalent.

Output voltage specification:

0.12 — 1 V (at 20 Hz)

NOTE:

Regarding terminal No., please refer to item 1. ABS WHEEL SPEED SENSOR. <Ref. to ABS-15, ABS WHEEL SPEED SENSOR, INSPECTION, Front ABS Wheel Speed Sensor.>

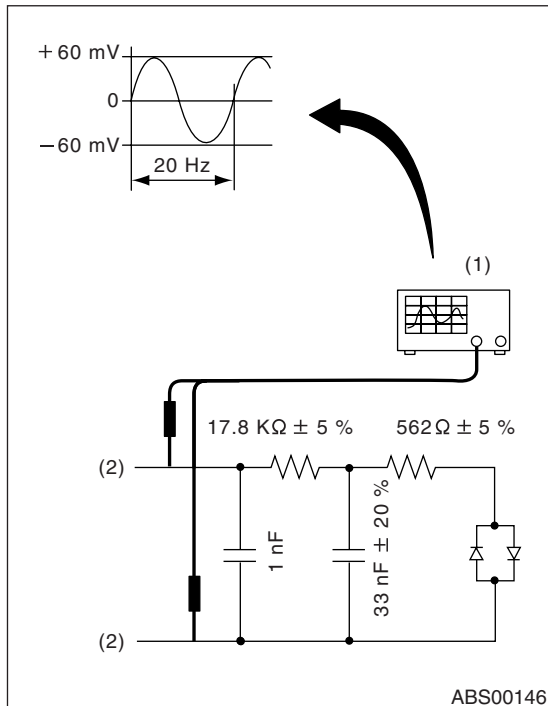

(1) Oscilloscope

(2) Terminal

D: ADJUSTMENT

Adjust the gap using spacer (Part No. 26755A000).