

34. Oil Pump Housing

A: REMOVAL

- 1) Remove the transmission assembly from the vehicle. <Ref. to 4AT-39, REMOVAL, Automatic Transmission Assembly.>
- 2) Extract the torque converter clutch assembly. <Ref. to 4AT-84, REMOVAL, Torque Converter Clutch Assembly.>
- 3) Remove the input shaft.

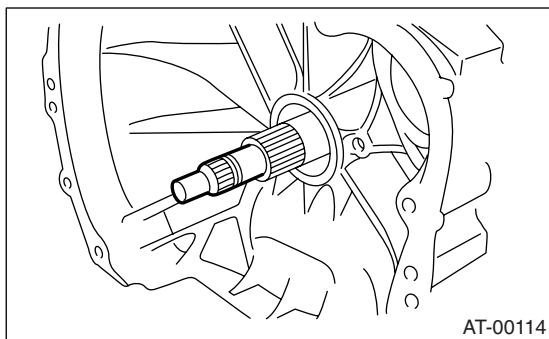

- 4) Lift-up lever behind the transmission harness connector and disconnect it from stay.
- 5) Disconnect inhibitor switch connector from stay.
- 6) Remove the ATF charger pipe. <Ref. to 4AT-83, REMOVAL, ATF Charger Pipe.>
- 7) Remove the ATF cooler inlet and outlet pipes. <Ref. to 4AT-79, REMOVAL, ATF Cooler Pipe and Hose.>
- 8) Separation of torque converter clutch case and transmission case sections <Ref. to 4AT-97, REMOVAL, Torque Converter Clutch Case.>
- 9) Separate transmission case and extension case sections. <Ref. to 4AT-85, REMOVAL, Extension Case.>
- 10) Remove the reduction drive gear. <Ref. to 4AT-94, REMOVAL, Reduction Drive Gear.>
- 11) Remove the reduction driven gear. <Ref. to 4AT-92, REMOVAL, Reduction Driven Gear.>
- 12) Loosen the oil pump housing mounting bolts.

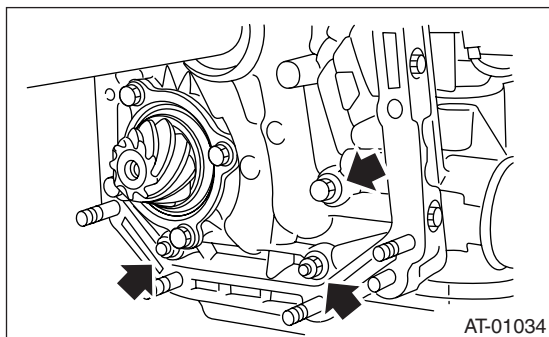

- 13) Place two wooden blocks on the workbench, and stand the transmission case with its rear end facing down.

CAUTION:

Be careful not to scratch the rear mating surface of the transmission case.

NOTE:

Note that the parking rod and drive pinion protrude from the mating surface.

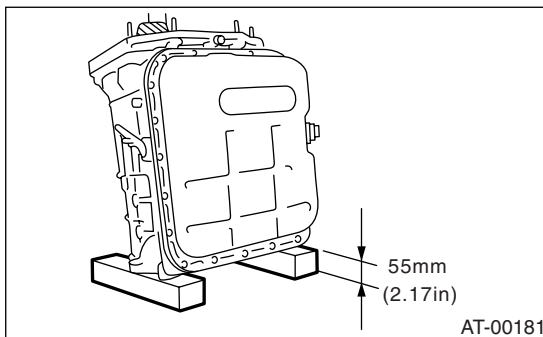

- 14) Remove the oil pump housing and adjusting thrust washer.

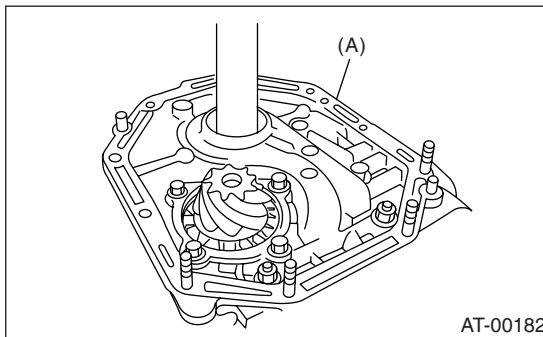

(A) Oil pump housing

B: INSTALLATION

1) Secure the oil pump housing with two nuts and the bolt.

Tightening torque:

42 N·m (4.3 kgf·m, 31 ft·lb)

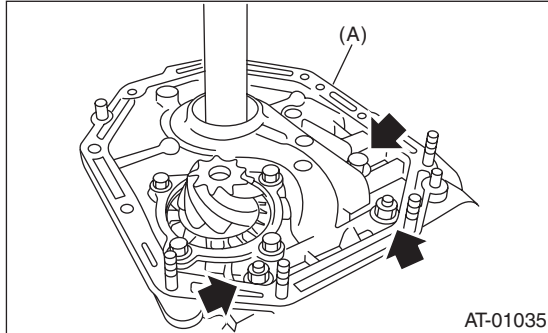

(A) Oil pump housing

2) Install the torque converter clutch case to the transmission case. <Ref. to 4AT-84, INSTALLATION, Torque Converter Clutch Assembly.>

3) Install reduction driven gear. <Ref. to 4AT-92, INSTALLATION, Reduction Driven Gear.>

4) Install the reduction drive gear. <Ref. to 4AT-94, INSTALLATION, Reduction Drive Gear.>

5) Combine the extension case with the transmission case. <Ref. to 4AT-85, INSTALLATION, Extension Case.>

6) Insert inhibitor switch and transmission connector into stay.

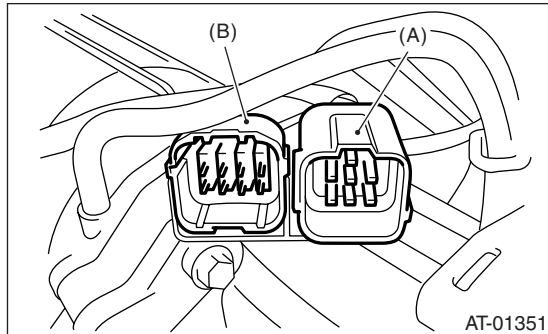

(A) Transmission harness ASSY

(B) Inhibitor switch harness

7) Install the ATF cooler pipe. <Ref. to 4AT-80, INSTALLATION, ATF Cooler Pipe and Hose.>

8) Install the ATF charger pipe with O-ring. <Ref. to 4AT-83, INSTALLATION, ATF Charger Pipe.>

9) Insert the input shaft while turning lightly by hand and verify the protrusion amount.

Normal protrusion A:

50 — 55 mm (1.97 — 2.17 in)

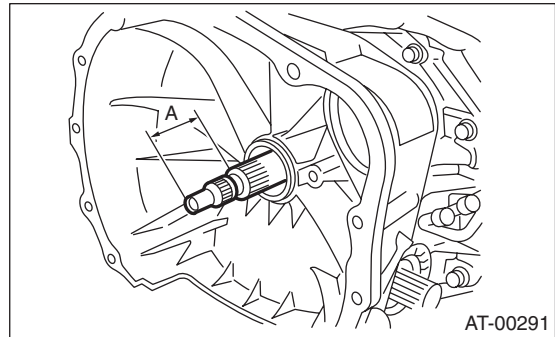

10) Install the torque converter clutch assembly. <Ref. to 4AT-84, INSTALLATION, Torque Converter Clutch Assembly.>

11) Install the transmission assembly to the vehicle. <Ref. to 4AT-42, INSTALLATION, Automatic Transmission Assembly.>

OIL PUMP HOUSING

AUTOMATIC TRANSMISSION

C: DISASSEMBLY

1. OIL PUMP COVER

1) Remove four seal rings.

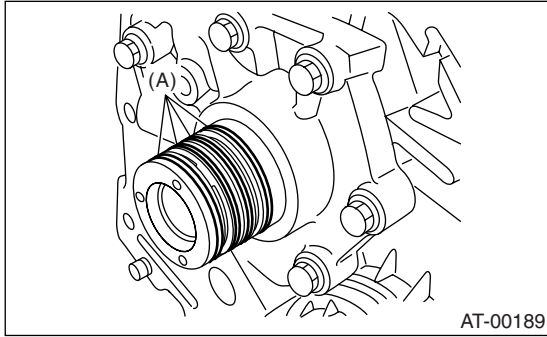

(A) Seal rings

2) Remove the securing bolts, and then tap the end of the stator shaft lightly to remove the cover.

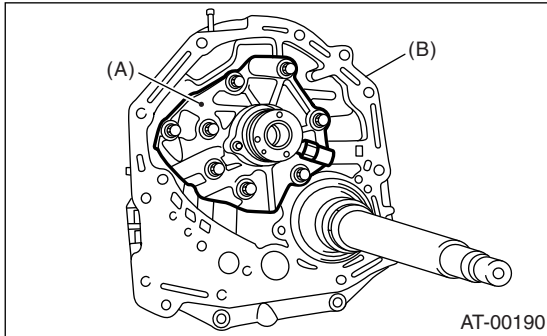

(A) Oil pump cover
(B) Oil pump housing

3) Remove the oil pump inner and outer rotor.

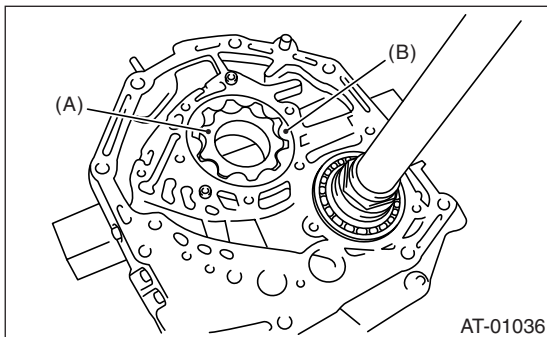

(A) Oil pump inner rotor
(B) Oil pump outer rotor

2. OIL SEAL RETAINER

1) Remove the oil seal retainer.

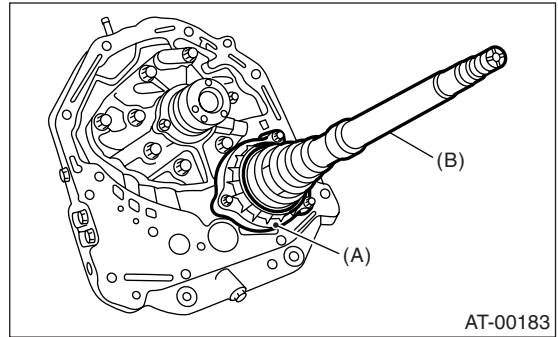

(A) Oil seal retainer
(B) Drive pinion shaft

2) Remove the O-ring.

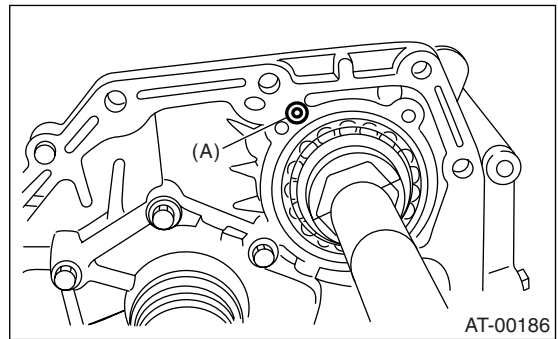

(A) O-ring

3) Remove the oil seal from oil seal retainer.

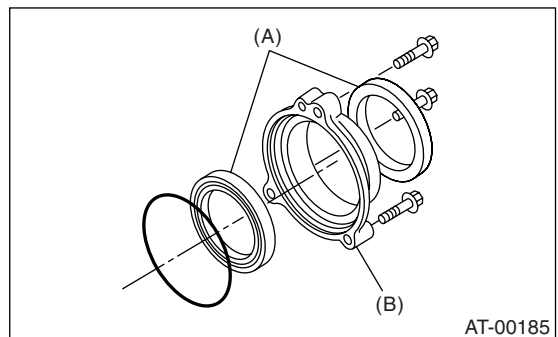

(A) Oil seal
(B) Oil seal retainer

D: ASSEMBLY

1. OIL PUMP COVER

1) Install oil pump rotor assembly to oil pump housing.

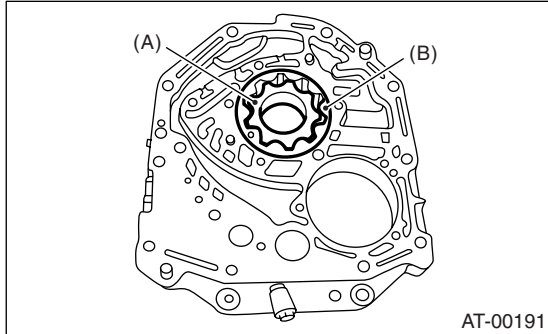

- (A) Oil pump inner rotor
- (B) Oil pump outer rotor

2) Align both pivots with the pivot holes of the cover, and install the oil pump cover being careful not to apply undue force to the pivots.

Tightening torque:

25 N·m (2.5 kgf·m, 18.1 ft·lb)

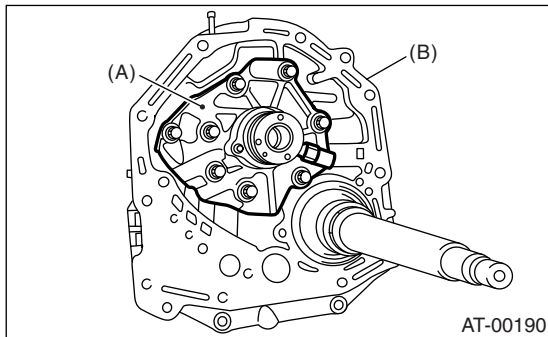

- (A) Oil pump cover
- (B) Oil pump housing

3) After assembling, turn the oil pump shaft to check for smooth rotation of the rotor.

4) Install the oil seal retainer and new seal rings. After adjusting the drive pinion backlash and tooth contact. <Ref. to 4AT-105, ADJUSTMENT, Oil Pump Housing.>

CAUTION:

Two types of sealing exist and are identified by color. Referring to the following figure, install them to the proper position.

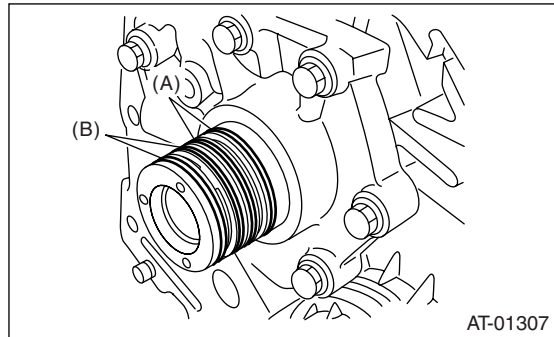

- (A) Seal rings (Black)
- (B) Seal rings (Brown)

2. OIL SEAL RETAINER

1) Install two new oil seals to the oil seal retainer in proper position using ST.

ST 499247300 INSTALLER

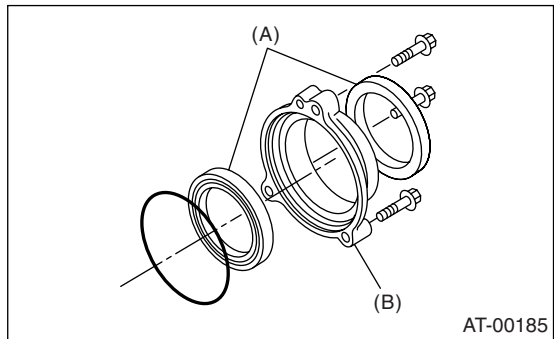

- (A) Oil seal
- (B) Oil seal retainer

2) Install a new O-ring to the oil seal retainer using Vaseline.

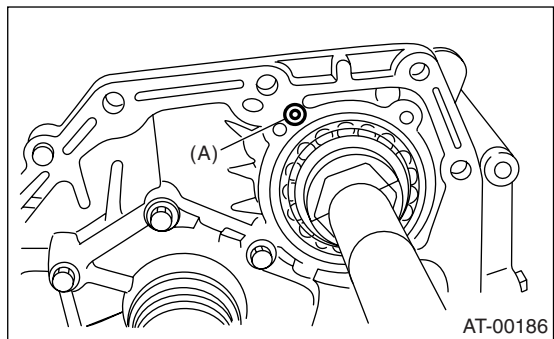

- (A) O-ring

OIL PUMP HOUSING

AUTOMATIC TRANSMISSION

3) Install the oil seal and secure it using three bolts being careful not to damage oil seal lip.

Tightening torque:

7 N·m (0.7 kgf·m, 5.1 ft-lb)

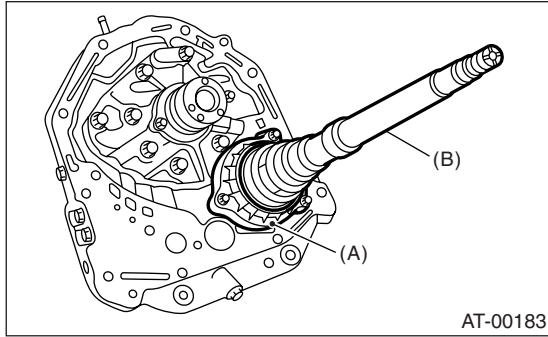

- (A) Oil seal retainer
- (B) Drive pinion shaft

E: INSPECTION

- 1) Check seal ring and O-ring oil seal for breaks or damage.
- 2) Check other parts for dents or abnormalities.
- 3) Selection of oil pump rotor assembly

(1) Tip clearance

Install oil pump inner rotor and oil pump outer rotor to oil pump. With rotor gears facing each other, measure crest-to-crest clearance.

Tip clearance:

0.02 — 0.15 mm (0.0008 — 0.0059 in)

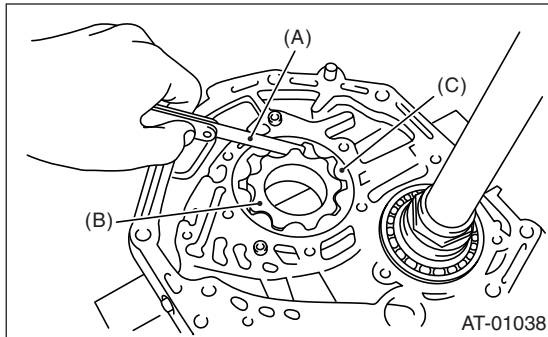

- (A) Thickness gauge
- (B) Oil pump inner rotor
- (C) Oil pump outer rotor

(2) Side clearance

Set a depth gauge to oil pump housing, then measure oil pump housing-to-rotor clearances.

Side clearance:

0.02 — 0.04 mm (0.0008 — 0.0016 in)

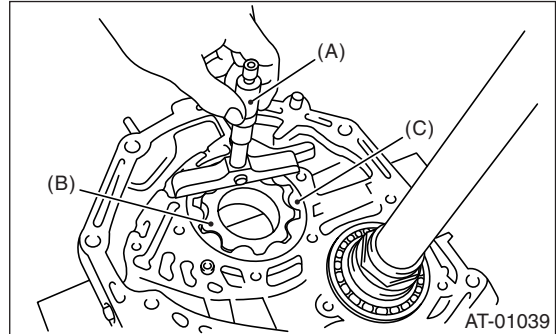

- (A) Depth gauge
- (B) Oil pump inner rotor
- (C) Oil pump outer rotor

(3) If depth and/or side clearances are outside specifications, replace oil pump rotor assembly.

Oil pump rotor assembly	
Part No.	Thickness mm (in)
15008AA060	11.37 — 11.38 (0.4476 — 0.4480)
15008AA070	11.38 — 11.39 (0.4480 — 0.4484)
15008AA080	11.39 — 11.40 (0.4484 — 0.4488)

Measure the total end play and adjust to within specifications. <Ref. to 4AT-105, ADJUSTMENT, Oil Pump Housing.>

F: ADJUSTMENT

1) Using ST, measure the distance from the transmission case mating surface to the recessed portion of the high clutch drum "L".

ST 398643600 GAUGE

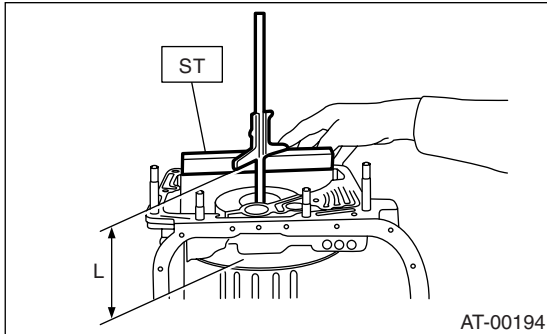

2) Using ST, measure the distance from the oil pump housing mating surface to the top surface of the oil pump cover with thrust needle bearing.

ST 398643600 GAUGE

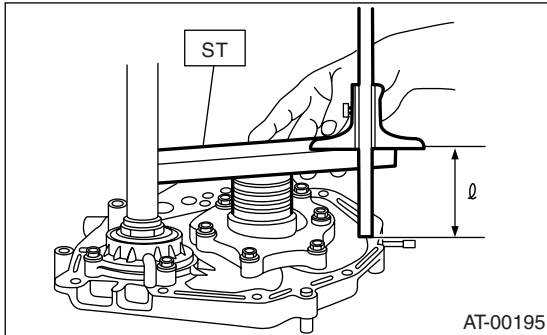

3) Calculation of total end play

Select suitable thrust needle bearing from among those listed in this table so that clearance C is in the 0.25 to 0.55 mm (0.0098 to 0.0217 in) range.

$$C = (L + G) - l$$

C	Clearance between concave portion of high clutch and end of clutch drum support
L	Length from transmission case mating surface to concave portion of high clutch
G	Gasket thickness [0.28 mm (0.0110 in)]
l	Height from oil pump housing mating surface to upper surface of oil pump cover with thrust needle bearing

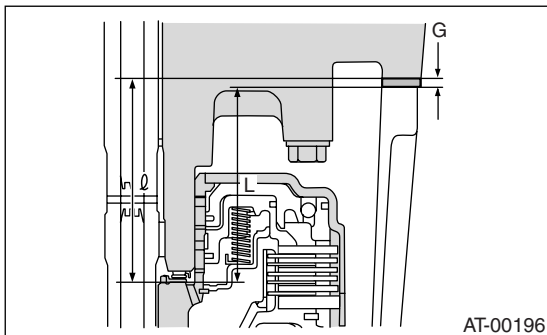

Thrust needle bearing	
Part No.	Thickness mm (in)
806528050	4.1 (0.161)
806528060	4.3 (0.169)
806528070	4.5 (0.177)
806528080	4.7 (0.185)
806528090	4.9 (0.193)
806528100	5.1 (0.201)

4) After completing end play adjustment, insert the bearing race in the recess of the high clutch. Attach the thrust needle bearing to the oil pump cover with Vaseline.

5) After correctly installing the new gasket to the case mating surface, carefully install the oil pump housing assembly. Be careful to avoid hitting the drive pinion against the inside of the case.

6) Install both parts with dowel pins aligned. Make sure no clearance exists at the mating surface.