

# DRIVE PINION SHAFT

## AUTOMATIC TRANSMISSION

### 35. Drive Pinion Shaft

#### A: REMOVAL

- 1) Remove the transmission assembly from vehicle. <Ref. to 4AT-39, REMOVAL, Automatic Transmission Assembly.>
- 2) Extract the torque converter clutch assembly. <Ref. to 4AT-84, REMOVAL, Torque Converter Clutch Assembly.>
- 3) Remove the input shaft.

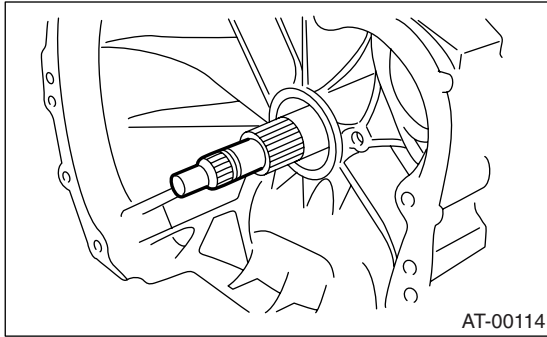

- 4) Lift-up lever behind the transmission harness connector and disconnect it from stay.
- 5) Disconnect inhibitor switch connector from stay.
- 6) Disconnect the air breather hose. <Ref. to 4AT-82, REMOVAL, Air Breather Hose.>
- 7) Remove the ATF charger pipe. <Ref. to 4AT-83, REMOVAL, ATF Charger Pipe.>
- 8) Remove the ATF cooler inlet and outlet pipes. <Ref. to 4AT-79, REMOVAL, ATF Cooler Pipe and Hose.>
- 9) Separation of torque converter clutch case and transmission case sections <Ref. to 4AT-97, REMOVAL, Torque Converter Clutch Case.>
- 10) Separate transmission case and extension case sections. <Ref. to 4AT-85, REMOVAL, Extension Case.>
- 11) Remove the reduction drive gear. <Ref. to 4AT-94, REMOVAL, Reduction Drive Gear.>
- 12) Remove the reduction driven gear. <Ref. to 4AT-92, REMOVAL, Reduction Driven Gear.>
- 13) Remove the drive pinion shaft mounting bolt and remove the drive shaft assembly from oil pump housing.

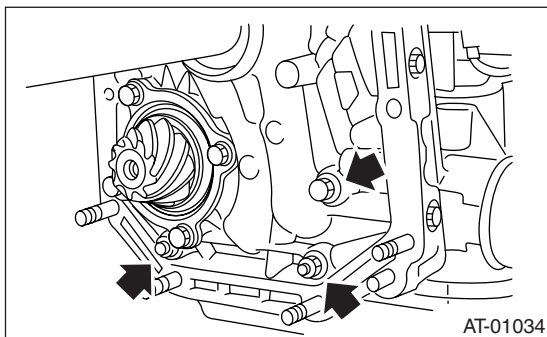

#### B: INSTALLATION

- 1) Assemble the drive pinion assembly to the oil pump housing.

#### NOTE:

- Pay attention not to bend the shim.
- Pay attention not to press the pinion into housing bore.

#### Tightening torque:

**40 N·m (4.1 kgf·m, 29.5 ft·lb)**

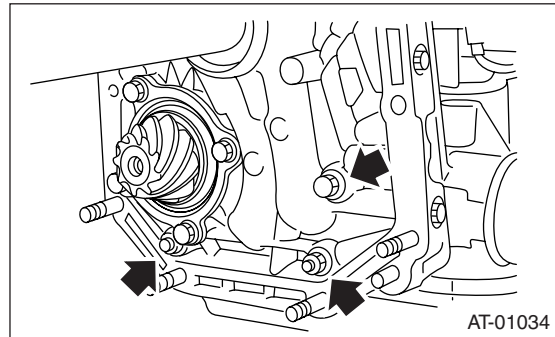

- 2) Combine the torque converter case with the transmission case. <Ref. to 4AT-98, INSTALLATION, Torque Converter Clutch Case.>
- 3) Install the reduction driven gear. <Ref. to 4AT-92, INSTALLATION, Reduction Driven Gear.>
- 4) Install the reduction drive gear. <Ref. to 4AT-94, INSTALLATION, Reduction Drive Gear.>
- 5) Combine the extension case with the transmission case. <Ref. to 4AT-85, INSTALLATION, Extension Case.>
- 6) Insert inhibitor switch and transmission connector into stay.
- 7) Install the air breather hose. <Ref. to 4AT-82, INSTALLATION, Air Breather Hose.>
- 8) Install the ATF cooler inlet and outlet pipes. <Ref. to 4AT-80, INSTALLATION, ATF Cooler Pipe and Hose.>
- 9) Install the ATF charger pipe with O-ring.
- 10) Insert the input shaft while turning lightly by hand and verify the protrusion amount.

#### Normal protrusion A:

**50 — 55 mm (1.97 — 2.17 in)**

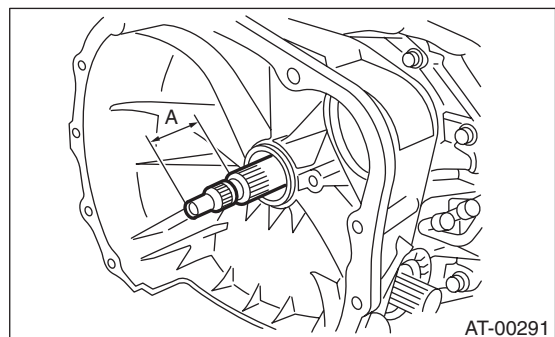

# DRIVE PINION SHAFT

AUTOMATIC TRANSMISSION

11) Install the torque converter clutch assembly.  
<Ref. to 4AT-84, INSTALLATION, Torque Converter Clutch Assembly.>

12) Install the transmission assembly to vehicle.  
<Ref. to 4AT-42, INSTALLATION, Automatic Transmission Assembly.>

## C: DISASSEMBLY

1) Straighten the staked portion of the lock nut, and remove the lock nut while locking the rear spline portion of the drive pinion shaft with ST1 and ST2. Then pull off the drive pinion collar.

ST1 498937110 HOLDER  
ST2 499787700 WRENCH  
ST3 499787500 ADAPTER

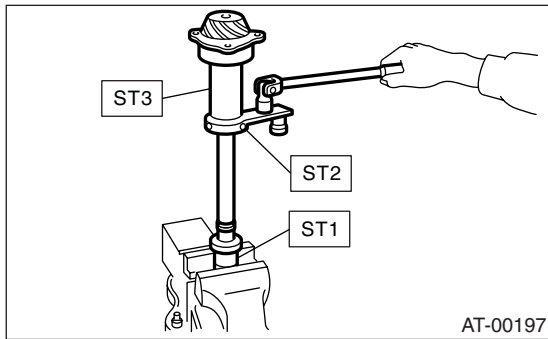

2) Remove the O-ring.

3) Using a press, separate the rear roller bearing and outer race from the drive pinion shaft.

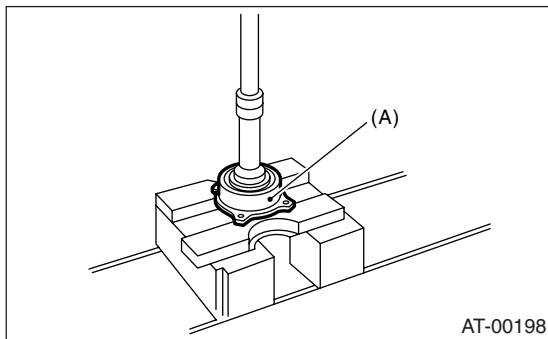

(A) Outer race

4) Using a press and ST, separate the front roller bearing from the drive pinion shaft.

ST 498517000 REPLACER

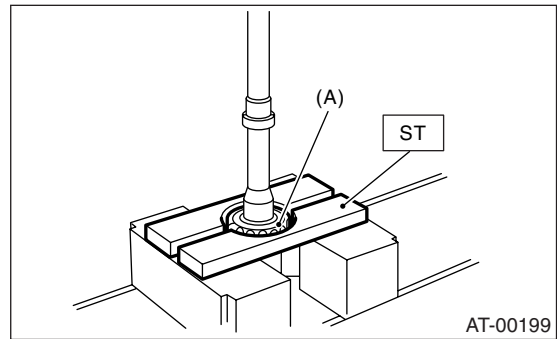

(A) Front roller bearing

# DRIVE PINION SHAFT

## AUTOMATIC TRANSMISSION

### D: ASSEMBLY

- 1) Measure dimension "A" of the drive pinion shaft.  
ST 398643600 GAUGE

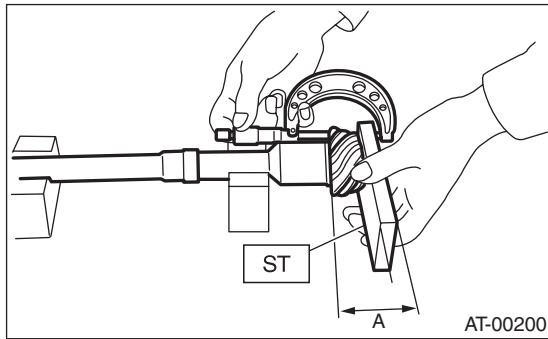

- 2) Using a press, force-fit a new roller bearing in position.

**NOTE:**

If too much pressure is applied, the roller bearing will not turn easily.

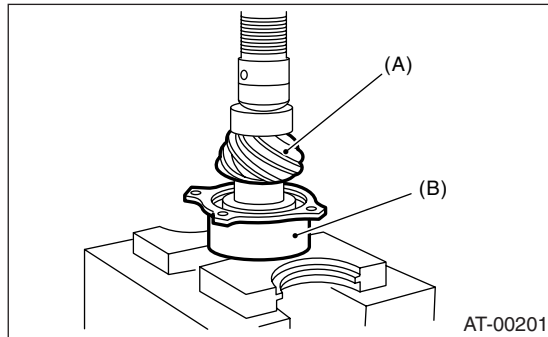

- (A) Drive pinion shaft  
(B) Roller bearing

- 3) After fitting a new O-ring to the drive pinion shaft, attach the drive pinion collar to the drive pinion shaft.

- 4) Install the lock washer to drive pinion shaft in proper direction.

- 5) Tighten a new lock nut with ST1, ST2 and ST3. Calculate lock washer and lock nut specifications using the following formula.

$$T2 = L2 / (L1 + L2) \times T1$$

T1: 116 N·m (11.8 kgf·m, 85.3 ft·lb)

[Required torque setting]

T2: Tightening torque

L1: ST2 length 0.072 m (2.83 in)

L2: Torque wrench length

Example:

Torque wrench length m (in)	Tightening torque N·m (kgf·m, ft·lb)
0.4 (15.75)	98 (10.0, 72.3)
0.45 (17.72)	100 (10.2, 73.5)
0.5 (19.69)	101 (10.3, 74.6)
0.55 (21.65)	102 (10.4, 75.4)

- ST1 498937110 HOLDER  
ST2 499787700 WRENCH  
ST3 499787500 ADAPTER

**NOTE:**

Install ST2 to torque wrench as straight as possible.

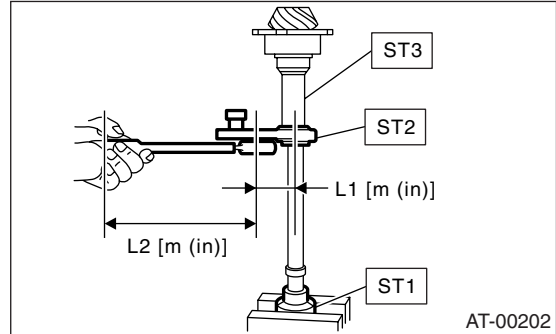

- 6) Measure the starting torque of the bearing. Make sure the starting torque is within the specified range. If out of the allowable range, replace the roller bearing.

**Starting torque:**

7.6 — 38.1 N (0.776 — 3.88 kgf, 1.7 — 8.6 lb)

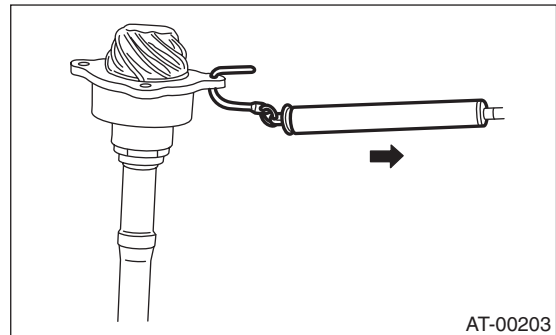

- 7) Stake the lock nut securely at two places.

- 8) Measure dimension "B" of the drive pinion shaft.

- ST 398643600 GAUGE

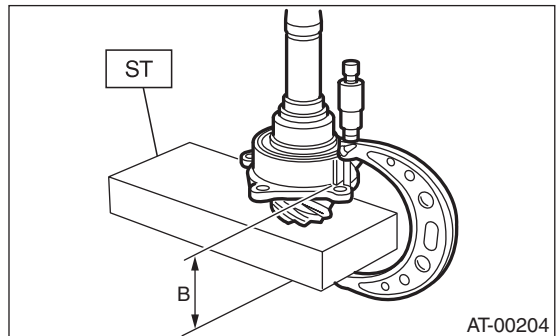

- 9) The thickness "t" (mm) of the drive pinion shim.  
 $t = 6.5 \pm 0.0625 - (B - A)$

10) Select three or less shims from following table.

Available drive pinion shims	
Part No.	Thickness mm (in)
31451AA050	0.150 (0.0059)
31451AA060	0.175 (0.0069)
31451AA070	0.200 (0.0079)
31451AA080	0.225 (0.0089)
31451AA090	0.250 (0.0098)
31451AA100	0.275 (0.0108)

## E: INSPECTION

- Make sure that all component parts are free of harmful cuts, gouges, and other faults.
- Adjust the teeth alignment. <Ref. to 4AT-109, ADJUSTMENT, Drive Pinion Shaft.>

## F: ADJUSTMENT

- 1) Thoroughly remove the liquid gasket from the case mating surface beforehand.
- 2) Install the oil pump housing assembly to the torque converter clutch case, and secure evenly by tightening four bolts.

### NOTE:

Use an old gasket or an aluminum washer so as not to damage the mating surface of the housing.

### Tightening torque:

**41 N·m (4.2 kgf-m, 30.4 ft-lb)**

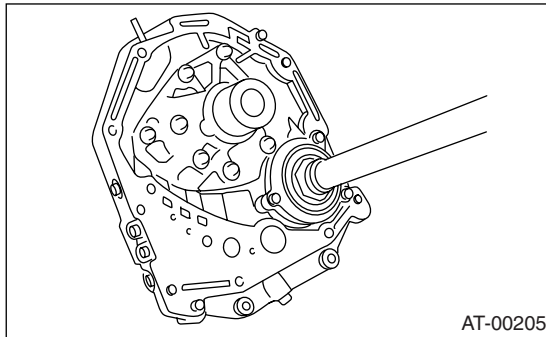

3) Rotate the drive pinion several times with ST1 and ST2.

ST1 498937110 HOLDER

ST2 499787700 WRENCH

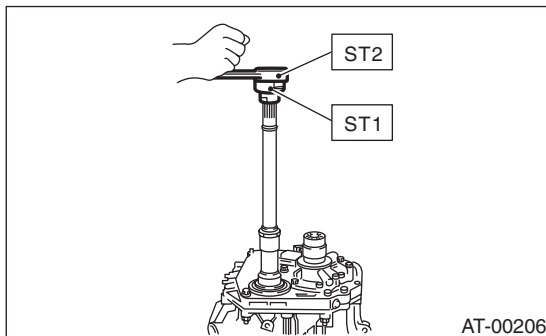

4) Adjust the backlash between drive pinion and hypoid driven gear. <Ref. to 4AT-116, ADJUSTMENT, Front Differential.>

5) Apply red lead evenly to the surfaces of three or four teeth of the hypoid driven gear. Rotate the drive pinion in the forward and reverse directions several times. Then remove the oil pump housing, and check the tooth contact pattern.

If tooth contact is improper, readjust the backlash or shim thickness. <Ref. to 4AT-116, ADJUSTMENT, Front Differential.>

- Tooth contact

**Checking item: Tooth contact pattern is slightly shifted toward to toe side under no-load rotation. [When loaded, contact pattern moves toward heel.]**

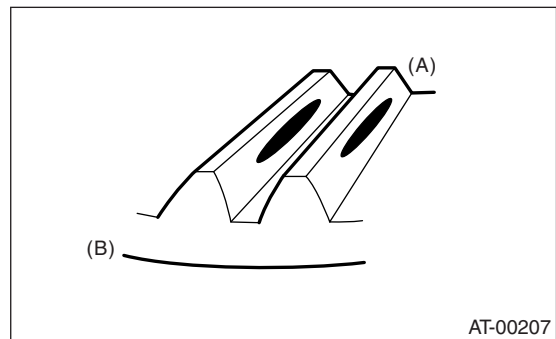

(A) Toe side

(B) Heel side

- Face contact

**Checking item: Backlash is too large. Contact pattern**

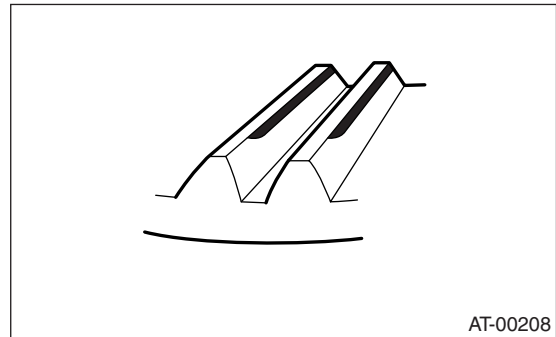

# DRIVE PINION SHAFT

## AUTOMATIC TRANSMISSION

Corrective action: Increase thickness of drive pinion height adjusting washer in order to bring drive pinion shaft close to hypoid driven gear.

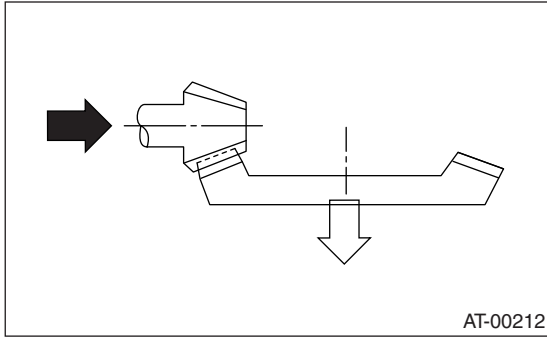

• Flank contact  
**Checking item: Backlash is too small.**  
Contact pattern

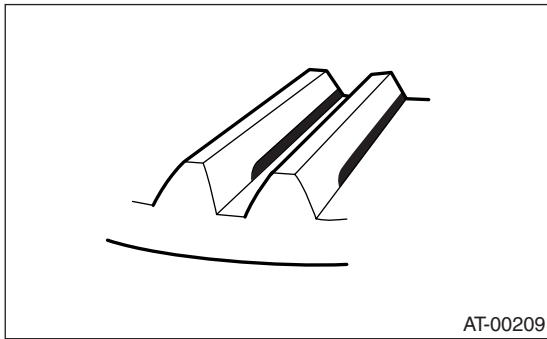

Corrective action: Reduce thickness of drive pinion height adjusting washer in order to move drive pinion shaft away from hypoid driven gear.

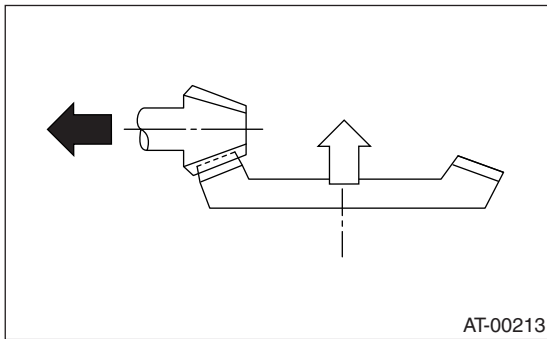

• Toe contact (Inside end contact)  
**Checking item: Contact areas is small.**  
Contact pattern

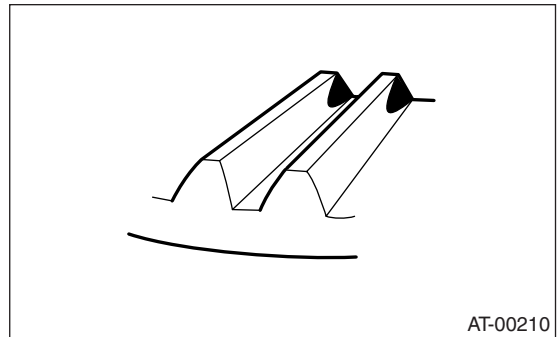

Corrective action: Decrease thickness of drive pinion height adjusting washer in order to move drive pinion shaft away from hypoid driven gear.

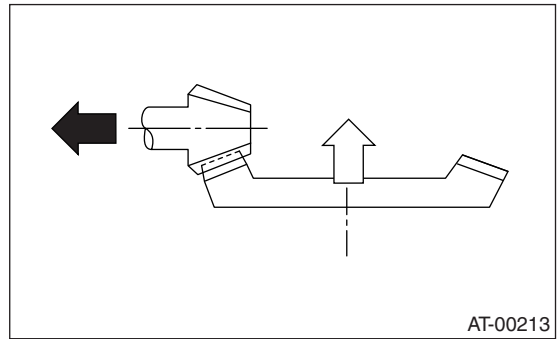

• Heel contact (Outside end contact)  
**Checking item: Contact areas is small.**  
Contact pattern

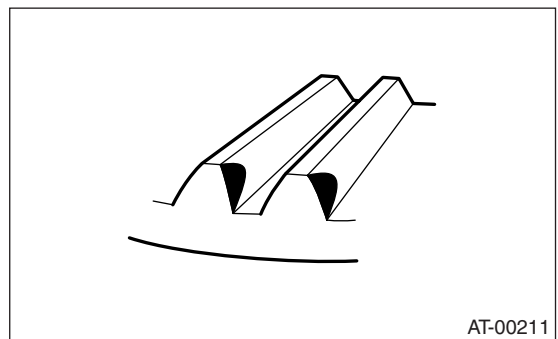

Corrective action: Increase thickness of drive pinion height adjusting washer in order to move drive pinion shaft close to hypoid driven gear.

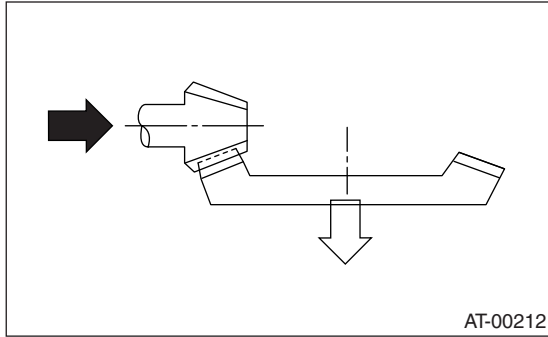

6) If tooth contact is correct, mark the differential side retainer position and loosen it. After fitting a new O-ring and oil seal, screw in the differential side retainer to the marked position. Then tighten the lock plate to the specified torque.

**Tightening torque:**

**25 N·m (2.5 kgf·m, 18.1 ft·lb)**

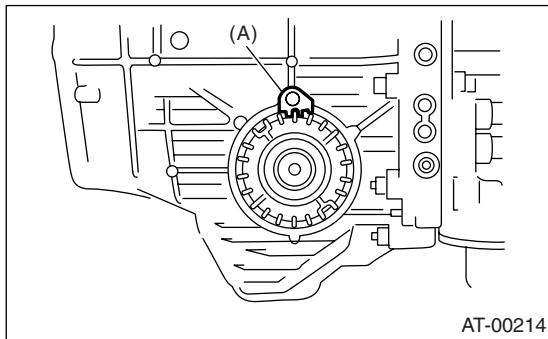

(A) Lock plate