

# **MECHANICAL**

# General Description

MECHANICAL

## 1. General Description

### A: SPECIFICATION

Engine	Cylinder arrangement		Horizontally opposed, liquid cooled, 4-cylinder, 4-stroke gasoline engine	
	Valve system mechanism		Belt driven, double overhead camshaft, 4-valve/cylinder	
	Bore × Stroke		mm (in) 99.5 × 79.0 (3.917 × 3.110)	
	Piston displacement		cm <sup>3</sup> (cu in) 2,457 (150)	
	Compression ratio		8.2	
	Compression pressure (at 200 — 300 rpm)		kPa (kgf/cm <sup>2</sup> , psi) 981 — 1,177 (10 — 12, 142 — 171)	
	Number of piston rings		Pressure ring: 2, Oil ring: 1	
	Intake valve timing	Opening	Max. retard	ATDC 5°
			Min. advance	BTDC 15°
		Closing	Max. retard	ABDC 65°
			Min. advance	ABDC 45°
	Exhaust valve timing	Opening	BBDC 55°	
		Closing	ATDC 5°	
	Valve clearance	Intake	mm (in) 0.20±0.02 (0.0079±0.0008)	
		Exhaust	mm (in) 0.35±0.02 (0.0138±0.0008)	
Idling speed [At neutral position on MT]		rpm 700±100 (No load) 800±100 (A/C switch ON)		
Firing order		1 → 3 → 2 → 4		
Ignition timing		BTDC/rpm 17°±10°/700		

**NOTE:**

STD: Standard I.D.: Inner Diameter O.D.: Outer Diameter OS: Oversize US: Undersize

Belt tension adjuster	Protrusion of adjuster rod		mm (in) 5.2 — 6.2 (0.205 — 0.244)		
Belt tensioner	Spacer O.D.		mm (in) 17.955 — 17.975 (0.7069 — 0.7077)		
	Tensioner bushing I.D.		mm (in) 18.0 — 18.08 (0.7087 — 0.7118)		
	Clearance between spacer and bushing	mm (in)	STD	0.025 — 0.125 (0.0010 — 0.0049)	
			Limit	0.175 (0.0069)	
	Side clearance of spacer	mm (in)	STD	0.2 — 0.55 (0.0079 — 0.0217)	
Limit			0.81 (0.0319)		
Camshaft	Bend limit		mm (in) 0.020 (0.00079)		
	Thrust clearance	mm (in)	STD	0.068 — 0.116 (0.0027 — 0.0046)	
			Limit	0.14 (0.0055)	
	Cam lobe height	mm (in)	Intake	STD	46.55 — 46.65 (1.833 — 1.837)
				Limit	46.45 (1.829)
		Exhaust	STD	46.75 — 46.85 (1.841 — 1.844)	
			Limit	46.65 (1.837)	
	Journal O.D.	mm (in)	STD	Front	37.946 — 37.963 (1.4939 — 1.4946)
				Center rear	29.946 — 29.963 (1.1790 — 1.1796)
	Oil clearance at journal	mm (in)	STD	0.037 — 0.072 (0.0015 — 0.0028)	
Limit			0.10 (0.0039)		
Cylinder head	Surface warpage limit		mm (in) 0.035 (0.0014)		
	Surface grinding limit		mm (in) 0.3 (0.012)		
	Standard height		mm (in) 127.5 (5.02)		

# General Description

MECHANICAL

Valve seat	Refacing angle			90°	
	Contacting width	mm (in)	Intake	STD	0.6 — 1.4 (0.024 — 0.055)
				Limit	1.7 (0.067)
		Exhaust	STD	1.2 — 1.8 (0.047 — 0.071)	
			Limit	2.2 (0.087)	
Valve guide	Inner diameter			6.000 — 6.012 (0.2362 — 0.2367)	
	Protrusion above head			15.8 — 16.2 (0.622 — 0.638)	
Valve	Head edge thickness	mm (in)	Intake	STD	1.0 — 1.4 (0.039 — 0.055)
				Limit	0.8 (0.031)
		Exhaust	STD	1.3 — 1.7 (0.051 — 0.067)	
			Limit	0.8 (0.031)	
	Stem diameter	mm (in)	Intake	5.955 — 5.970 (0.2344 — 0.2350)	
			Exhaust	5.945 — 5.960 (0.2341 — 0.2346)	
	Stem oil clearance	mm (in)	STD	Intake	0.030 — 0.057 (0.0012 — 0.0022)
				Exhaust	0.040 — 0.067 (0.0016 — 0.0026)
	Overall length	mm (in)		Intake	104.4 (4.110)
				Exhaust	104.65 (4.120)
Valve spring	Free length			47.32 (1.863)	
	Squareness			2.5°, 2.1 mm (0.083 in) or less	
	Tension/spring height	N (kgf, lbf)/mm (in)	Set	205 — 235 (20.9 — 24.0, 46.1 — 52.8)/36.0 (1.417)	
Lift			426 — 490 (43.4 — 50.0, 95.8 — 110)/26.50 (1.043)		
Cylinder block	Surface warpage limit (mating with cylinder head)			0.025 (0.00098)	
	Surface grinding limit			0.1 (0.004)	
	Standard height			201.0 (7.91)	
	Cylinder bore	mm (in)	STD	A	99.505 — 99.515 (3.9175 — 3.9179)
				B	99.495 — 99.505 (3.9171 — 3.9175)
	Taper	mm (in)	STD	0.015 (0.0006)	
			Limit	0.050 (0.0020)	
	Out-of-roundness	mm (in)	STD	0.010 (0.0004)	
			Limit	0.050 (0.0020)	
	Piston clearance	mm (in)	STD	-0.010 — 0.010 (-0.0004 — 0.0004)	
Limit			0.030 (0.0012)		
Cylinder enlarging (boring) limit (dia.)			To 100.005 (3.937)		
Piston	Outer diameter	mm (in)	STD	99.505 — 99.515 (3.9175 — 3.9179)	
			A	99.495 — 99.505 (3.9171 — 3.9175)	
			0.25 (0.0098) OS	99.745 — 99.765 (3.9270 — 3.9278)	
			0.50 (0.0197) OS	99.995 — 100.015 (3.9368 — 3.9376)	
Piston pin	Standard clearance between piston pin and hole in piston		mm (in)	STD	0.004 — 0.008 (0.0002 — 0.0003)
			Limit	0.020 (0.0008)	
	Degree of fit		Piston pin must be fitted into position with thumb at 20°C (68°F).		

## General Description

### MECHANICAL

Piston ring	Piston ring gap	mm (in)	Top ring	STD	0.20 — 0.25 (0.0079 — 0.0098)
			Limit		1.0 (0.039)
		Second ring	STD	0.37 — 0.52 (0.015 — 0.020)	
			Limit	1.0 (0.039)	
	Oil ring	STD	0.20 — 0.50 (0.0079 — 0.0197)		
		Limit	1.5 (0.059)		
	Ring groove gap	mm (in)	Top ring	STD	0.040 — 0.080 (0.0016 — 0.0031)
			Limit	0.15 (0.0059)	
Second ring		STD	0.030 — 0.070 (0.0012 — 0.0028)		
		Limit	0.15 (0.0059)		
Connecting rod	Bend twist per 100 mm (3.94 in) in length	mm (in)	Limit		0.10 (0.0039)
	Side clearance	mm (in)	STD	0.070 — 0.330 (0.0028 — 0.0130)	
Connecting rod bearing	Oil clearance	mm (in)	STD	0.017 — 0.045 (0.0007 — 0.0018)	
			Limit	0.05 (0.0020)	
	Thickness at center portion	mm (in)	STD	1.490 — 1.502 (0.0587 — 0.0591)	
			0.03 (0.0012) US	1.504 — 1.512 (0.0592 — 0.0595)	
			0.05 (0.0020) US	1.514 — 1.522 (0.0596 — 0.0599)	
			0.25 (0.0098) US	1.614 — 1.622 (0.0635 — 0.0639)	
Connecting rod bushing	Clearance between piston pin and bushing	mm (in)	STD	0 — 0.022 (0 — 0.0009)	
			Limit	0.030 (0.0012)	

# General Description

MECHANICAL

Crankshaft	Bend limit		mm (in)	0.035 (0.0014)	
	Crank pin	mm (in)	Out-of-roundness		0.003 (0.0001)
			Cylindricity		0.004 (0.0002)
			Grinding limit (dia.)		To 51.750 (2.0374)
	Crank journal	mm (in)	Out-of-roundness		0.005 (0.0002)
			Cylindricity		0.006 (0.0002)
			Grinding limit (dia.)		To 59.750 (2.3524)
	Crank pin outer diameter	mm (in)	STD		51.984 — 52.000 (2.0466 — 2.0472)
			0.03 (0.0012) US		51.954 — 51.970 (2.0454 — 2.0461)
			0.05 (0.0020) US		51.934 — 51.950 (2.0447 — 2.0453)
			0.25 (0.0098) US		51.734 — 51.750 (2.0368 — 2.0374)
	Crank journal outer diameter	mm (in)	STD		59.992 — 60.008 (2.3619 — 2.3625)
			0.03 (0.0012) US		59.962 — 59.978 (2.3607 — 2.3613)
			0.05 (0.0020) US		59.942 — 59.958 (2.3599 — 2.3605)
			0.25 (0.0098) US		59.742 — 59.758 (2.3520 — 2.3527)
	Side clearance	mm (in)	STD		0.030 — 0.115 (0.0012 — 0.0045)
			Limit		0.25 (0.0098)
	Oil clearance	mm (in)	STD		0.010 — 0.030 (0.0004 — 0.0012)
Limit			0.040 (0.0016)		
Main bearing	Main bearing thickness	#1, #3	STD		1.998 — 2.011 (0.0787 — 0.0792)
			0.03 (0.0012) US		2.017 — 2.020 (0.0794 — 0.0795)
			0.05 (0.0020) US		2.027 — 2.030 (0.0798 — 0.0799)
			0.25 (0.0098) US		2.127 — 2.130 (0.0837 — 0.0839)
		#2, #4, #5	STD		2.000 — 2.013 (0.0787 — 0.0793)
			0.03 (0.0012) US		2.019 — 2.022 (0.0795 — 0.0796)
			0.05 (0.0020) US		2.029 — 2.032 (0.0799 — 0.0800)
			0.25 (0.0098) US		2.129 — 2.132 (0.0838 — 0.0839)

# General Description

MECHANICAL

## B: COMPONENT

### 1. TIMING BELT

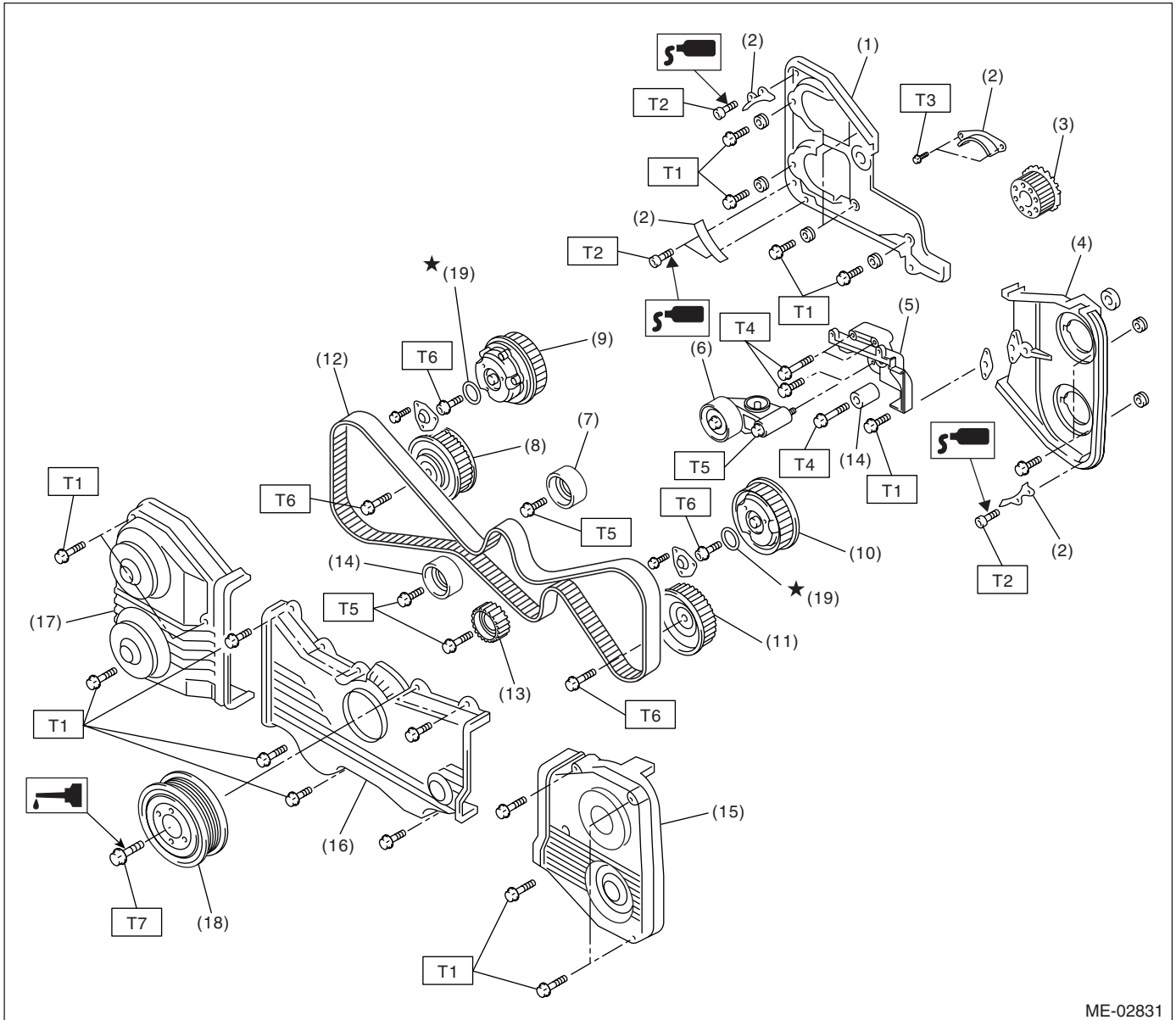

ME-02831

- |  |                                |
|--|--------------------------------|
| (1) Timing belt cover No. 2 (RH)         | (11) Exhaust cam sprocket (LH) |
| (2) Timing belt guide                    | (12) Timing belt               |
| (3) Crank sprocket                       | (13) Belt idler No. 2          |
| (4) Timing belt cover No. 2 (LH)         | (14) Belt idler                |
| (5) Tensioner bracket                    | (15) Timing belt cover (LH)    |
| (6) Automatic belt tension adjuster ASSY | (16) Front belt cover          |
| (7) Belt idler                           | (17) Timing belt cover (RH)    |
| (8) Exhaust cam sprocket (RH)            | (18) Crank pulley              |
| (9) Intake cam sprocket (RH)             | (19) O-ring                    |
| (10) Intake cam sprocket (LH)            |                                |

#### **Tightening torque: N-m (kgf-m, ft-lb)**

**T1: 5 (0.5, 3.6)**

**T2: 6.4 (0.65, 4.7)**

**T3: 9.75 (1.0, 7)**

**T4: 24.5 (2.5, 18.1)**

**T5: 39 (4.0, 28.9)**

**T6: <Ref. to ME(STI)-53, INSTALLATION, Crank Sprocket.>**

**T7: <Ref. to ME(STI)-42, INSTALLATION, Crank Pulley.>**

**ME(STI)-6**

## 2. CYLINDER HEAD AND CAMSHAFT

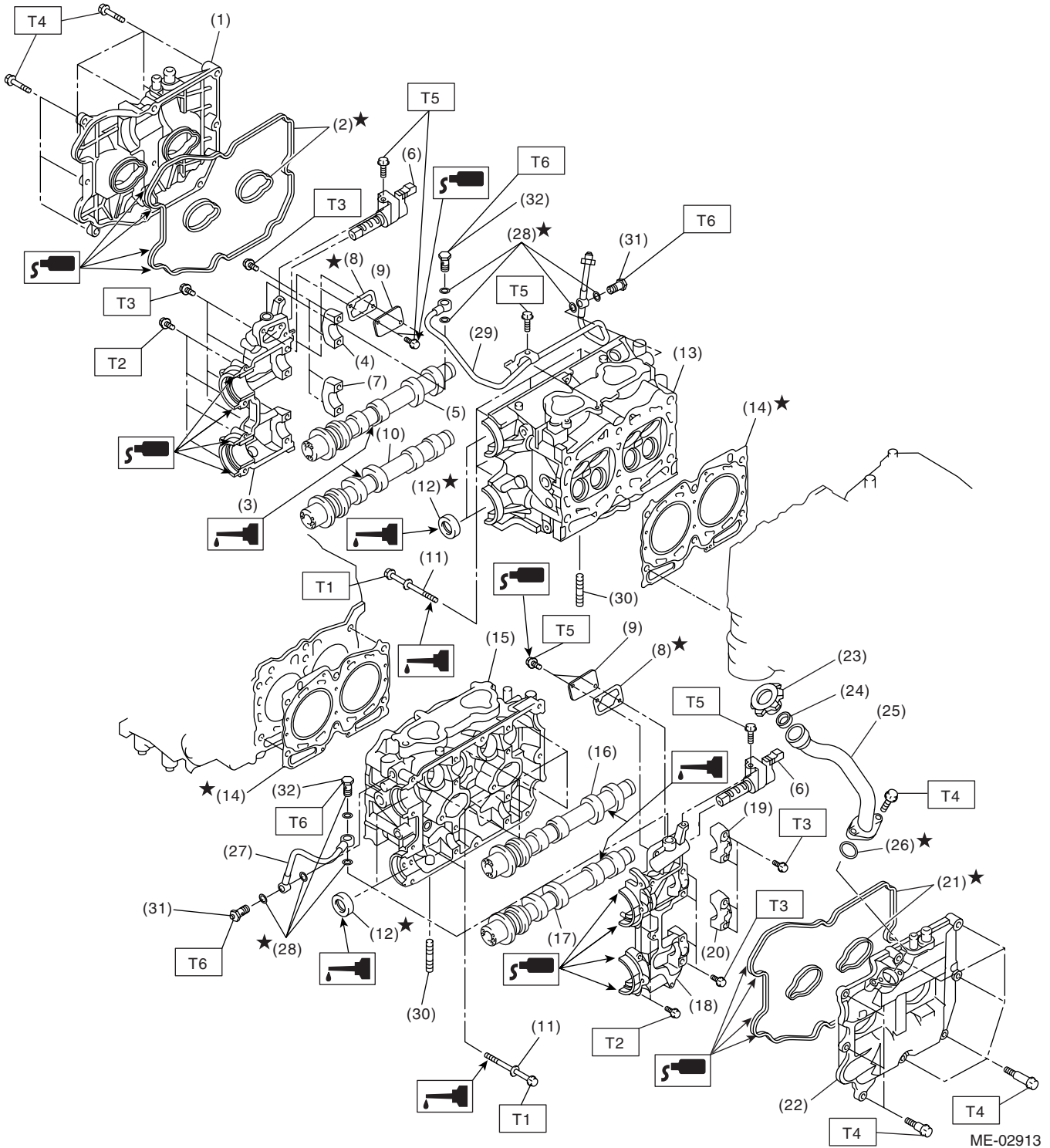

ME-02913

# General Description

## MECHANICAL

---

(1) Rocker cover (RH)	(16) Intake camshaft (LH)	(31) Union screw (with protrusion)
(2) Rocker cover gasket (RH)	(17) Exhaust camshaft (LH)	(32) Union screw (without protrusion)
(3) Camshaft cap (Front RH)	(18) Camshaft cap (Front LH)	
(4) Intake camshaft cap (Rear RH)	(19) Intake camshaft cap (Rear LH)	<hr/> <b>Tightening torque: N·m (kgf-m, ft-lb)</b>
(5) Intake camshaft (RH)	(20) Exhaust camshaft cap (Rear LH)	<b>T1: &lt;Ref. to ME(STI)-60, INSTALLATION, Cylinder Head.&gt;</b>
(6) Oil flow control solenoid valve	(21) Rocker cover gasket (LH)	<b>T2: &lt;Ref. to ME(STI)-55, INSTALLATION, Camshaft.&gt;</b>
(7) Exhaust camshaft cap (Rear RH)	(22) Rocker cover (LH)	<b>T3: &lt;Ref. to ME(STI)-55, INSTALLATION, Camshaft.&gt;</b>
(8) Gasket	(23) Oil filler cap	<b>T4: 6.4 (0.65, 4.7)</b>
(9) Oil return cover	(24) Gasket	<b>T5: 8 (0.8, 5.9)</b>
(10) Exhaust camshaft (RH)	(25) Oil filler duct	<b>T6: 29 (3.0, 21.4)</b>
(11) Cylinder head bolt	(26) O-ring	<hr/>
(12) Oil seal	(27) Oil pipe (LH)	
(13) Cylinder head (RH)	(28) Gasket	
(14) Cylinder head gasket	(29) Oil pipe (RH)	
(15) Cylinder head (LH)	(30) Stud bolt	



## 3. CYLINDER HEAD AND VALVE ASSEMBLY

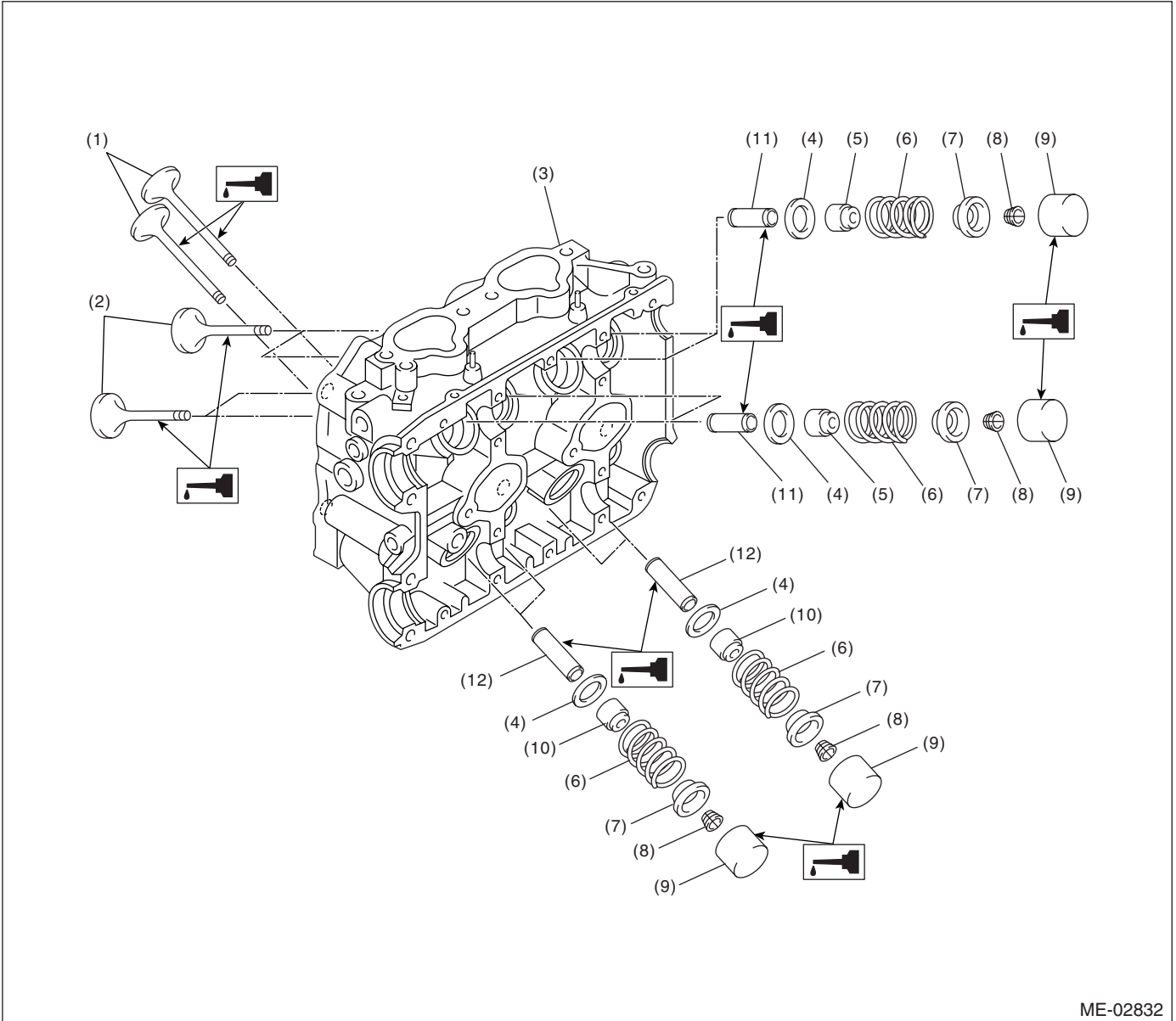

ME-02832

- |                       |                           |                             |
|-----------------------|---------------------------|-----------------------------|
| (1) Exhaust valve     | (5) Intake valve oil seal | (9) Valve lifter            |
| (2) Intake valve      | (6) Valve spring          | (10) Exhaust valve oil seal |
| (3) Cylinder head     | (7) Retainer              | (11) Intake valve guide     |
| (4) Valve spring seat | (8) Retainer key          | (12) Exhaust valve guide    |

# General Description

MECHANICAL

## 4. CYLINDER BLOCK

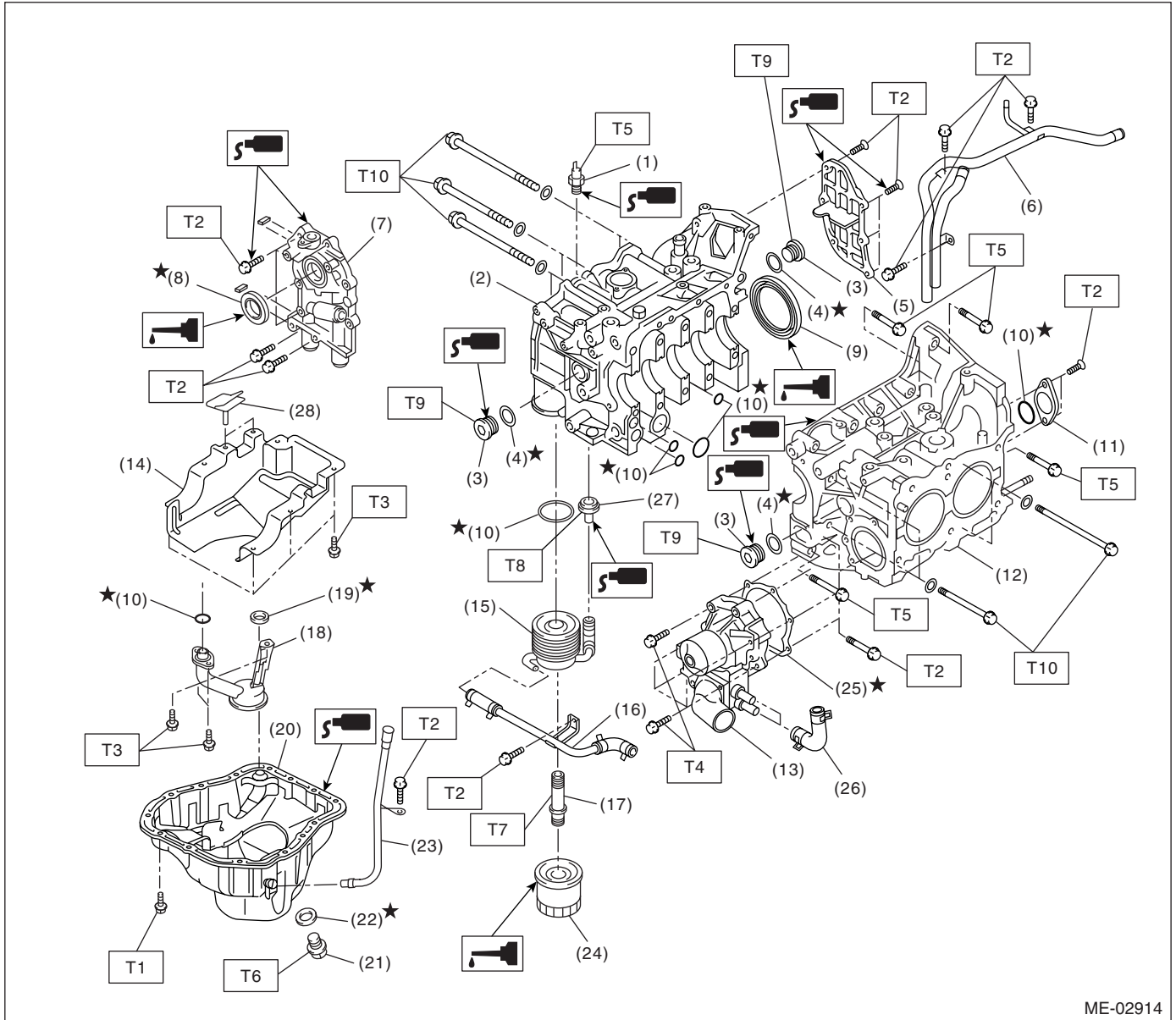

ME-02914

- |                          |                            |
|--------------------------|----------------------------|
| (1) Oil pressure switch  | (15) Oil cooler            |
| (2) Cylinder block (RH)  | (16) Water by-pass pipe    |
| (3) Service hole plug    | (17) Connector             |
| (4) Gasket               | (18) Oil strainer          |
| (5) Oil separator cover  | (19) Gasket                |
| (6) Water by-pass pipe   | (20) Oil pan               |
| (7) Oil pump             | (21) Drain plug            |
| (8) Front oil seal       | (22) Metal gasket          |
| (9) Rear oil seal        | (23) Oil level gauge guide |
| (10) O-ring              | (24) Oil filter            |
| (11) Service hole cover  | (25) Gasket                |
| (12) Cylinder block (LH) | (26) Water pump hose       |
| (13) Water pump          | (27) Plug                  |
| (14) Baffle plate        | (28) Seal                  |

**Tightening torque: N·m (kgf·m, ft·lb)**

- T1: 5 (0.5, 3.6)**  
**T2: 6.4 (0.65, 4.7)**  
**T3: 10 (1.0, 7.4)**  
**T4: First 12 (1.2, 8.7)**  
**Second 12 (1.2, 8.7)**  
**T5: 25 (2.5, 18.4)**  
**T6: 44 (4.5, 33)**  
**T7: 54 (5.5, 40)**  
**T8: 69 (7.0, 50.9)**  
**T9: 70 (7.1, 51.6)**  
**T10: <Ref. to ME(STI)-70,**  
**INSTALLATION, Cylinder**  
**Block.>**

## 5. CRANKSHAFT AND PISTON

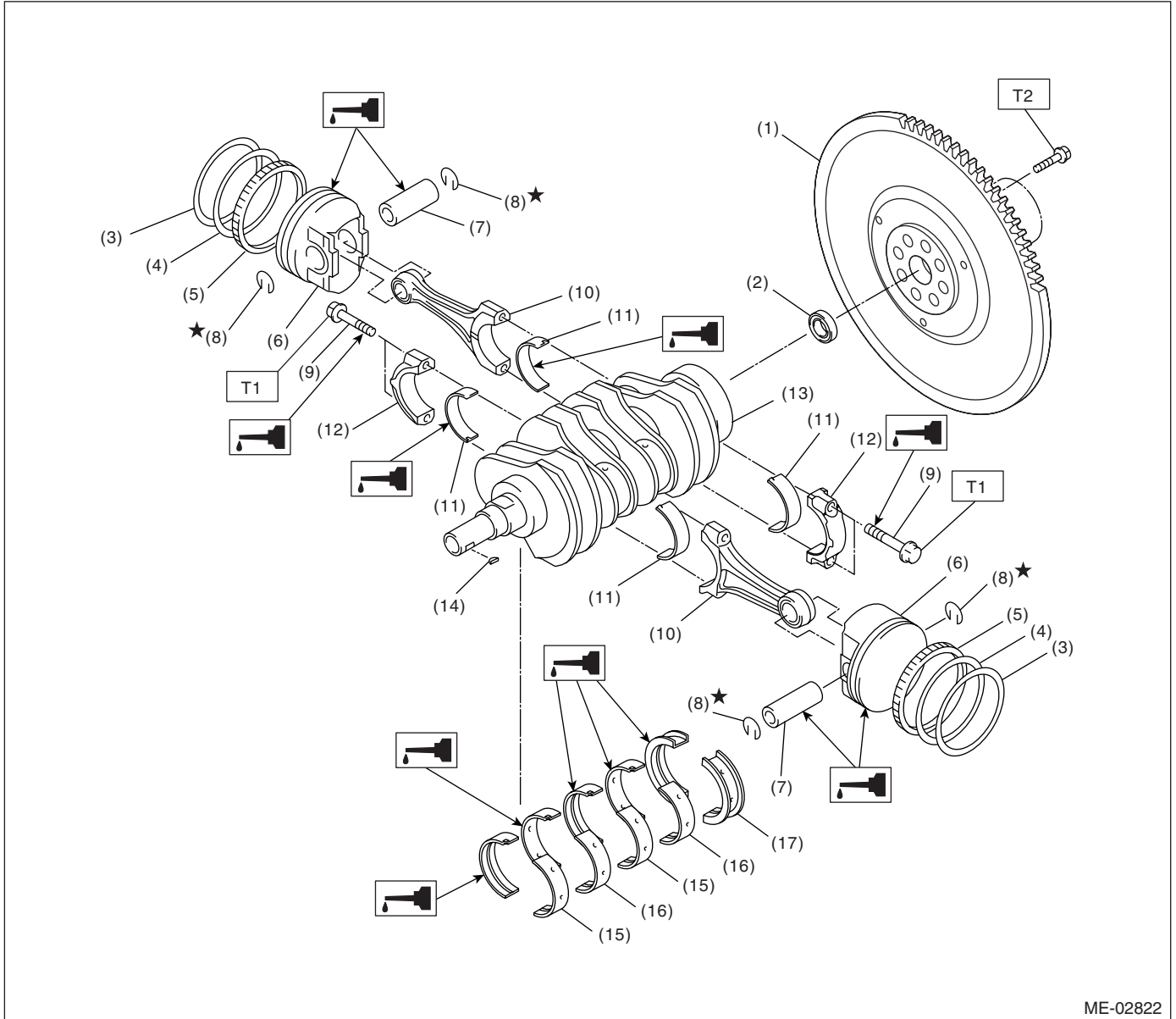

ME-02822

- |                  |                             |                                |
|------------------|-----------------------------|--------------------------------|
| (1) Flywheel     | (8) Snap ring               | (15) Crankshaft bearing #1, #3 |
| (2) Ball bearing | (9) Connecting rod bolt     | (16) Crankshaft bearing #2, #4 |
| (3) Top ring     | (10) Connecting rod         | (17) Crankshaft bearing #5     |
| (4) Second ring  | (11) Connecting rod bearing |                                |
| (5) Oil ring     | (12) Connecting rod cap     |                                |
| (6) Piston       | (13) Crankshaft             |                                |
| (7) Piston pin   | (14) Woodruff key           |                                |

---

**Tightening torque: N-m (kgf-m, ft-lb)**  
**T1: 52 (5.3, 38.4)**  
**T2: 75 (7.6, 55.3)**

---

# General Description

MECHANICAL

## 6. ENGINE MOUNTING

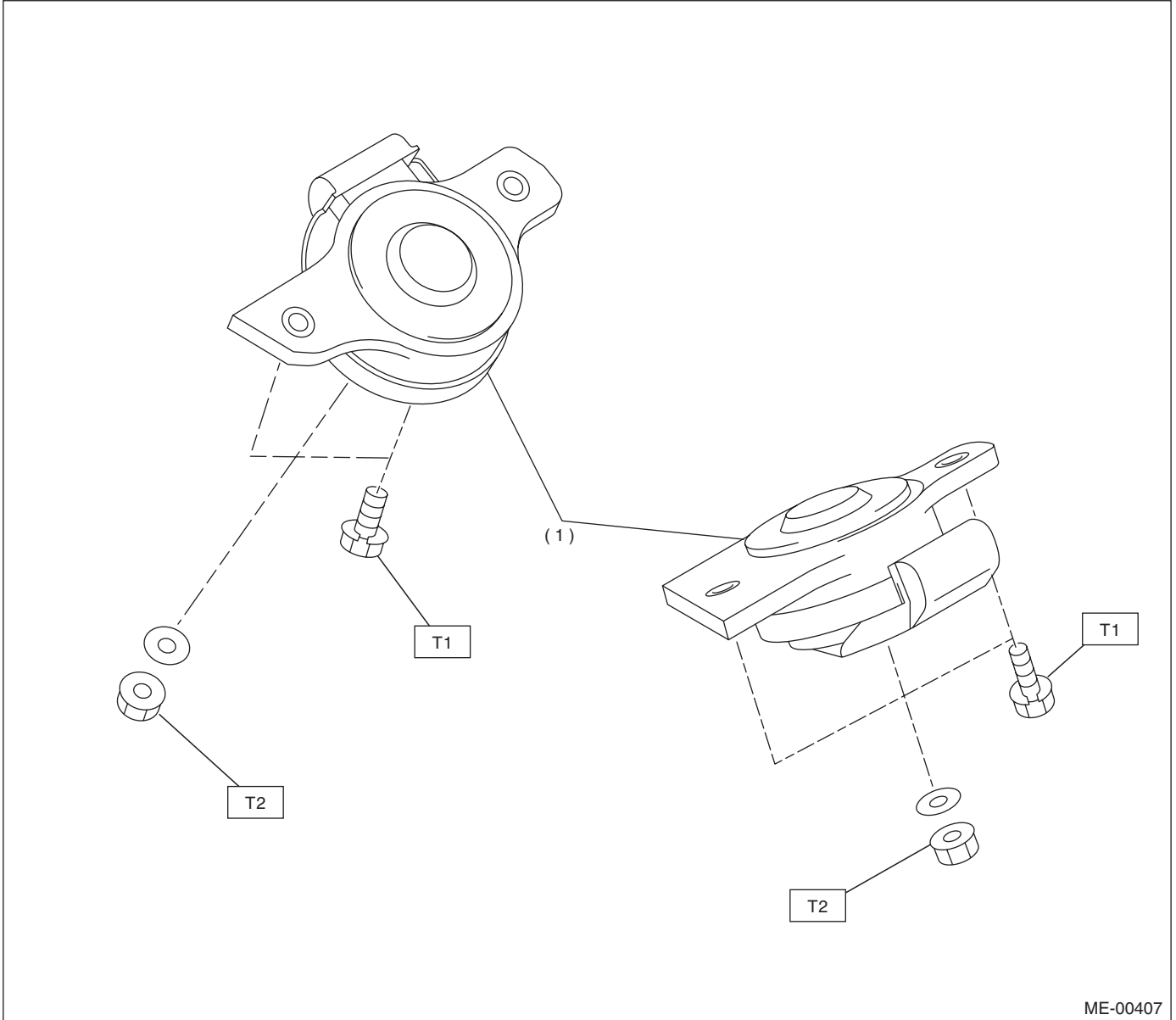

ME-00407

(1) Front cushion rubber

**Tightening torque: N·m (kgf·m, ft·lb)**

**T1: 35 (3.6, 25.8)**

**T2: 85 (8.7, 62.7)**

## **C: CAUTION**

- Wear work clothing, including a cap, protective goggles and protective shoes during operation.
- Remove contamination including dirt and corrosion before removal, installation or disassembly.
- Keep the disassembled parts in order and protect them from dust and dirt.
- Before removal, installation or disassembly, be sure to clarify the failure. Avoid unnecessary removal, installation, disassembly and replacement.
- Be careful not to burn yourself, because each part in the vehicle is hot after running.
- Be sure to tighten fasteners including bolts and nuts to the specified torque.
- Place shop jacks or rigid racks at the specified points.
- Before disconnecting electrical connectors of sensors or units, be sure to disconnect the ground cable from battery.
- All parts should be thoroughly cleaned, paying special attention to the engine oil passages, pistons and bearings.
- Rotating parts and sliding parts such as piston, bearing and gear should be coated with oil prior to assembly.
- Be careful not to let oil, grease or coolant contact the timing belt, clutch disc and flywheel.
- All removed parts, if to be reused, should be reinstalled in the original positions and directions.
- Bolts, nuts and washers should be replaced with new ones as required.
- Even if necessary inspections have been made in advance, proceed with assembly work while making rechecks.
- Remove or install the engine in an area where chain hoists, lifting devices, etc. are available for ready use.
- Be sure not to damage coated surfaces of body panels with tools or stain seats and windows with coolant or oil. Place a cover over fenders, as required, for protection.
- Prior to starting work, prepare the following: Service tools, clean cloth, containers to catch coolant and oil, wire ropes, chain hoist, transmission jacks, etc.
- Lift-up or lower the vehicle when necessary. Make sure to support the correct positions.

# General Description

MECHANICAL

## D: PREPARATION TOOL

### 1. SPECIAL TOOL

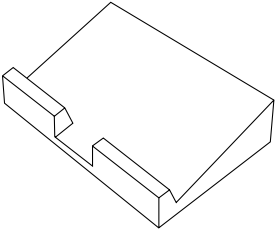
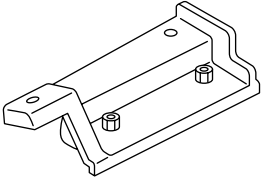
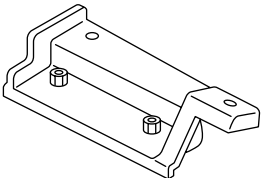
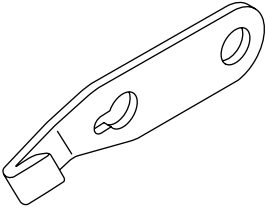
ILLUSTRATION	TOOL NUMBER	DESCRIPTION	REMARKS
 ST-498267600	498267600	CYLINDER HEAD TABLE	<ul style="list-style-type: none"><li>• Used for replacing valve guides.</li><li>• Used for removing and installing valve springs.</li></ul>
 ST-498457000	498457000	ENGINE STAND ADAPTER RH	Used with ENGINE STAND (499817000).
 ST-498457100	498457100	ENGINE STAND ADAPTER LH	Used with ENGINE STAND (499817000).
 ST-498497100	498497100	CRANKSHAFT STOPPER	Used for stopping rotation of flywheel when loosening and tightening crank pulley bolt, etc.

# General Description

MECHANICAL

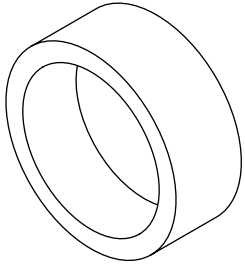
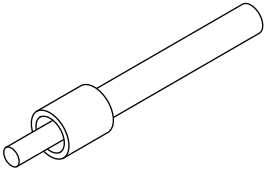
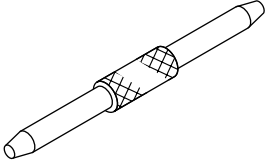
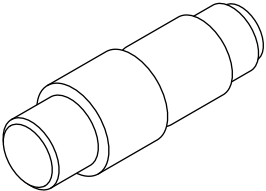
ILLUSTRATION	TOOL NUMBER	DESCRIPTION	REMARKS
 <p style="text-align: center;">ST-498747300</p>	498747300	PISTON GUIDE	Used for installing piston in cylinder for 2.5 L engine.
 <p style="text-align: center;">ST-498857100</p>	498857100	VALVE OIL SEAL GUIDE	Used for press-fitting of intake and exhaust valve guide oil seals.
 <p style="text-align: center;">ST-499017100</p>	499017100	PISTON PIN GUIDE	Used for installing piston pin, piston and connecting rod.
 <p style="text-align: center;">ST-499037100</p>	499037100	CONNECTING ROD BUSHING REMOVER AND INSTALLER	Used for removing and installing connecting rod bushing.

# General Description

## MECHANICAL

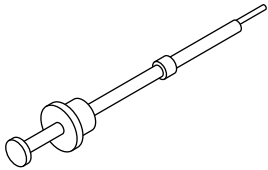
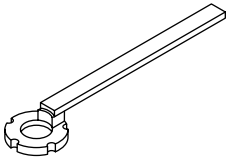
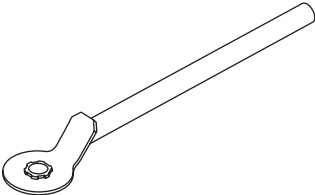
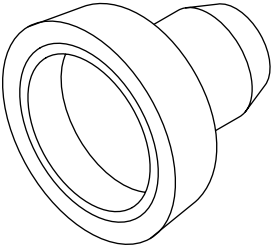
ILLUSTRATION	TOOL NUMBER	DESCRIPTION	REMARKS
 <p style="text-align: center;">ST-499097700</p>	499097700	PISTON PIN REMOVER ASSY	Used for removing piston pin.
 <p style="text-align: center;">ST-499207400</p>	499207400	CAM SPROCKET WRENCH	Used for removing and installing exhaust cam sprocket.
 <p style="text-align: center;">ST-499977500</p>	499977500	CAM SPROCKET WRENCH	Used for removing and installing intake cam sprocket.
 <p style="text-align: center;">ST-499587200</p>	499587200	CRANKSHAFT OIL SEAL INSTALLER	<ul style="list-style-type: none"> <li>• Used for installing crankshaft oil seal.</li> <li>• Used with CRANKSHAFT OIL SEAL GUIDE (499597100).</li> </ul>



# General Description

MECHANICAL

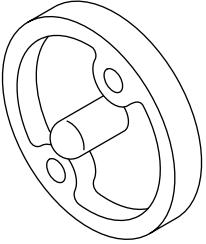
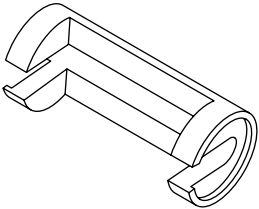
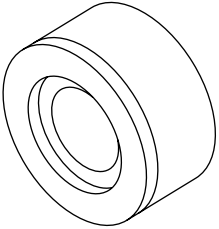
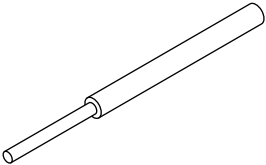
ILLUSTRATION	TOOL NUMBER	DESCRIPTION	REMARKS
 <p style="text-align: center;">ST-499597100</p>	499597100	CRANKSHAFT OIL SEAL GUIDE	<ul style="list-style-type: none"> <li>• Used for installing crankshaft oil seal.</li> <li>• Used with CRANKSHAFT OIL SEAL INSTALLER (499587200).</li> </ul>
 <p style="text-align: center;">ST-499718000</p>	499718000	VALVE SPRING REMOVER	Used for removing and installing valve spring.
 <p style="text-align: center;">ST18251AA020</p>	18251AA020	VALVE GUIDE ADJUSTER	Used for installing intake and exhaust valve guides.
 <p style="text-align: center;">ST-499767200</p>	499767200	VALVE GUIDE REMOVER	Used for removing valve guides.

# General Description

## MECHANICAL

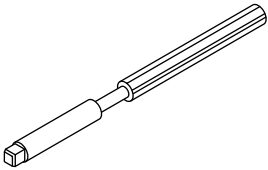
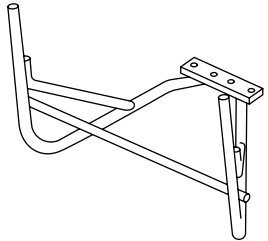
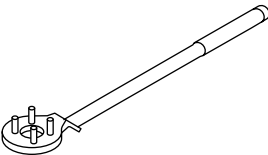
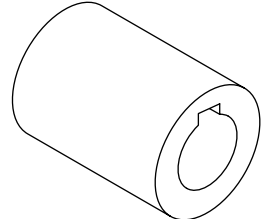
ILLUSTRATION	TOOL NUMBER	DESCRIPTION	REMARKS
 <p style="text-align: center;">ST-499767400</p>	499767400	VALVE GUIDE REAMER	Used for reaming valve guides.
 <p style="text-align: center;">ST-499817000</p>	499817000	ENGINE STAND	<ul style="list-style-type: none"> <li>• Stand used for engine disassembly and assembly.</li> <li>• Used with ENGINE STAND ADAPTER RH (498457000) and LH (498457100).</li> </ul>
 <p style="text-align: center;">ST-499977100</p>	499977100	CRANK PULLEY WRENCH	Used for stopping rotation of crank pulley when loosening and tightening crank pulley bolts.
 <p style="text-align: center;">ST-499987500</p>	499987500	CRANKSHAFT SOCKET	Used for rotating crankshaft.

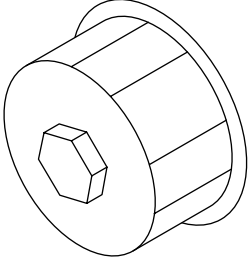
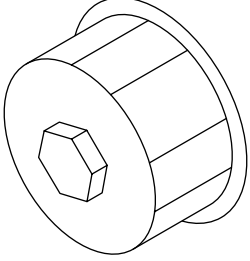
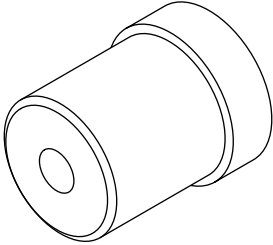
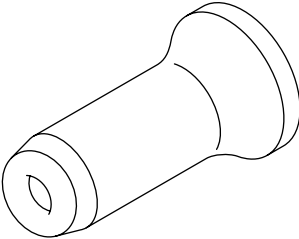

# General Description

MECHANICAL

ILLUSTRATION	TOOL NUMBER	DESCRIPTION	REMARKS
 <p style="text-align: center;">ST18332AA000</p>	18332AA000	OIL FILTER WRENCH	Used for removing and installing the oil filter. (Outer diameter: 68 mm (2.68 in))
 <p style="text-align: center;">ST18332AA010</p>	18332AA010	OIL FILTER WRENCH	Used for removing and installing the oil filter. (Outer diameter: 65 mm (2.56 in))
 <p style="text-align: center;">ST-499587100</p>	499587100	OIL SEAL INSTALLER	Used for installing oil pump oil seal.
 <p style="text-align: center;">ST-499587600</p>	499587600	OIL SEAL GUIDE	Used for installing camshaft oil seal for DOHC engine.

# General Description

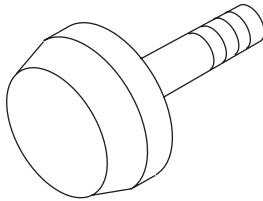
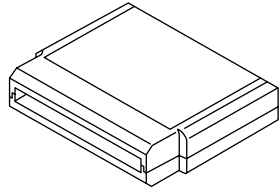
## MECHANICAL

ILLUSTRATION	TOOL NUMBER	DESCRIPTION	REMARKS
 ST-499597200	499597200	OIL SEAL GUIDE	<ul style="list-style-type: none"> <li>• Used for installing camshaft oil seal for DOHC engine.</li> <li>• Used with OIL SEAL GUIDE (499587600).</li> </ul>
 ST18482AA010	18482AA010 (Newly adopted tool)	CARTRIDGE	Troubleshooting for electrical systems.
 ST22771AA030	22771AA030	SUBARU SELECT MONITOR KIT	Troubleshooting for electrical systems.

## 2. GENERAL TOOL

TOOL NAME	REMARKS
Compression gauge	Used for measuring compression.

## E: PROCEDURE

It is possible to conduct the following service procedures with engine on the vehicle, however, the procedures described in this section are based on the condition that the engine is removed from the vehicle.

- V-belt
- Timing Belt
- Camshaft
- Cylinder Head

## 2. Compression

### A: INSPECTION

**CAUTION:**

**After warming-up, engine becomes very hot. Be careful not to burn yourself during measurement.**

- 1) After warming-up the engine, turn the ignition switch to OFF.
- 2) Make sure that the battery is fully charged.
- 3) Release the fuel pressure. <Ref. to FU(STI)-44, RELEASING OF FUEL PRESSURE, PROCEDURE, Fuel.>
- 4) Remove all the spark plugs. <Ref. to IG(STI)-4, REMOVAL, Spark Plug.>
- 5) Fully open the throttle valve.
- 6) Check the starter motor for satisfactory performance and operation.
- 7) Fix the compression gauge securely against spark plug hole.

**NOTE:**

The screw of screw-in type compression gauge (put into cylinder head spark plug hole) should be less than 18 mm (0.71 in) long.

- 8) Crank the engine by means of starter motor, and then read the maximum value on the gauge when the needle of gauge is steady.

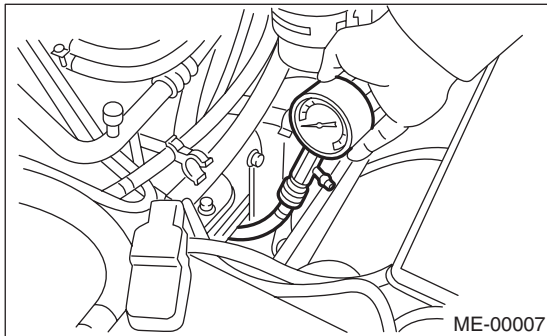

- 9) Perform at least two measurements per cylinder, and make sure that the values are correct.

**Compression (at 200 — 300 rpm):**

**Standard:**

**981 — 1,177 kPa (10 — 12 kgf/cm<sup>2</sup>, 142 — 171 psi)**

**Limit:**

**882 kPa (9.0 kgf/cm<sup>2</sup>, 128 psi)**

**Difference between cylinders**

**Less than 49 kPa (0.5 kgf/cm<sup>2</sup>, 7 psi)**

## 3. Idle Speed

### A: INSPECTION

1) Before checking the idle speed, check the following:

(1) Ensure the air cleaner element is free from clogging, ignition timing is correct, spark plugs are in good condition, and that the hoses are connected properly.

(2) Ensure the malfunction indicator light does not illuminate.

2) Warm-up the engine.

3) Stop the engine, and then turn the ignition switch to OFF.

4) Insert the cartridge to Subaru Select Monitor.

5) Connect the Subaru Select Monitor to data link connector.

6) Turn the ignition switch to ON, and Subaru Select Monitor power switch to ON.

7) Select the {2. Each System Check} in Main Menu.

8) Select the {Engine Control System} in Selection Menu.

9) Select the {1. Current Data Display & Save} in Engine Control System Diagnosis.

10) Select the {1.12 Data Display} in Data Display Menu.

11) Start the engine, and then read the engine idle speed.

12) Check the idle speed when unloaded. (With headlights, heater fan, rear defroster, radiator fan, air conditioning, etc. OFF)

***Idle speed [No load and gears in neutral]:***

***700±100 rpm***

13) Check the idle speed when loaded. (Turn the air conditioning switch to “ON” and operate the compressor for at least 1 minute before measurement.)

***Idle speed [A/C “ON”, no load and gears in neutral]:***

***800±100 rpm***

NOTE:

As the idle speed is automatically controlled, it can not be adjusted manually. If the idle speed is out of specifications, refer to General On-board Diagnosis Table under “Engine Control System”. <Ref. to EN(STI)(diag)-2, Basic Diagnostic Procedure.>

## 4. Ignition Timing

### A: INSPECTION

#### CAUTION:

**After warming-up, engine becomes very hot. Be careful not to burn yourself during measurement.**

- 1) Before checking the ignition timing speed, check the following:
  - (1) Ensure the air cleaner element is free from clogging, spark plugs are in good condition, and that hoses are connected properly.
  - (2) Ensure the malfunction indicator light does not illuminate.
- 2) Warm-up the engine.
- 3) Stop the engine, and then turn the ignition switch to OFF.
- 4) Insert the cartridge to Subaru Select Monitor.
- 5) Connect the Subaru Select Monitor to data link connector.
- 6) Turn the ignition switch to ON, and Subaru Select Monitor power switch to ON.
- 7) Select the {2. Each System Check} in Main Menu.
- 8) Select the {Engine Control System} in Selection Menu.
- 9) Select the {1. Current Data Display & Save} in Engine Control System Diagnosis.
- 10) Select the {1.12 Data Display} in Data Display Menu.
- 11) Start the engine and check the ignition timing at idle speed.

#### ***Ignition timing [BTDC/rpm]:***

***17°±10°/700***

If the timing is not correct, check the ignition control system. Refer to Engine Control System. <Ref. to EN(STI)(diag)-2, Basic Diagnostic Procedure.>

## 5. Intake Manifold Vacuum

### A: INSPECTION

- 1) Warm-up the engine.
- 2) Disconnect the brake vacuum hose from intake manifold, and then install the vacuum gauge.
- 3) Keep the engine at the idle speed, and then read the vacuum gauge indication.

By observing the gauge needle movement, the internal condition of engine can be diagnosed as described below.

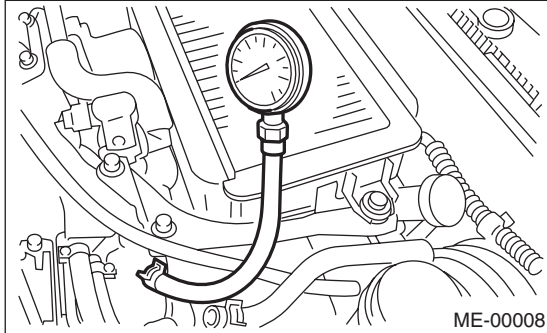

**Vacuum pressure (at idling, A/C "OFF"):**  
**Less than  $-60.0$  kPa ( $-450$  mmHg,  $-17.72$  in-Hg)**

Diagnosis of engine condition by measurement of manifold vacuum	
Vacuum gauge indication	Possible engine condition
1. Needle is steady but lower than normal position. This tendency becomes more evident as engine temperature rises.	Leakage around intake manifold gasket or disconnection or damaged vacuum hose
2. Needle intermittently drops to position lower than normal position.	Leakage around cylinder
3. Needle drops suddenly and intermittently from normal position.	Sticky valves
4. When engine speed is gradually increased, needle begins to vibrate rapidly at certain speed, and then vibration increases as engine speed increases.	Weak or broken valve springs
5. Needle vibrates above and below normal position in narrow range.	Defective ignition system or throttle chamber idle adjustment



## 6. Engine Oil Pressure

### A: INSPECTION

- 1) Remove the oil pressure switch from engine cylinder block. <Ref. to LU(STI)-18, REMOVAL, Oil Pressure Switch.>
- 2) Connect the oil pressure gauge hose to cylinder block.
- 3) Connect the battery ground cable to battery.
- 4) Start the engine, and then measure the oil pressure.

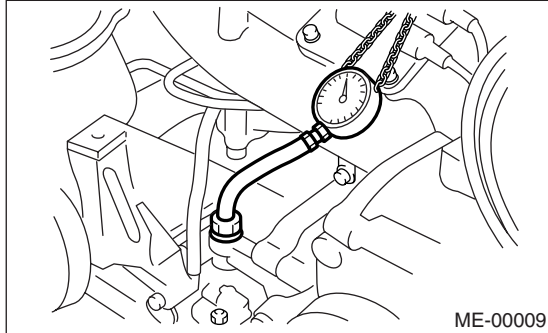

#### **Oil pressure:**

**98 kPa (1.0 kgf/cm<sup>2</sup>, 14 psi) or more at 600 rpm**

**294 kPa (3.0 kgf/cm<sup>2</sup>, 43 psi) or more at 5,000 rpm**

#### **CAUTION:**

- If the oil pressure is out of specification, check oil pump, oil filter and lubrication line. <Ref. to LU(STI)-21, INSPECTION, Engine Lubrication System Trouble in General.>
- If the oil pressure warning light is turned ON and oil pressure is in specification, replace the oil pressure switch. <Ref. to LU(STI)-21, INSPECTION, Engine Lubrication System Trouble in General.>

#### **NOTE:**

The specified data is based on an engine oil temperature of 80°C (176°F).

- 5) After measuring the oil pressure, install the oil pressure switch. <Ref. to LU(STI)-18, INSTALLATION, Oil Pressure Switch.>

#### **Tightening torque:**

**25 N·m (2.5 kgf-m, 18.4 ft-lb)**

## 7. Fuel Pressure

### A: INSPECTION

#### CAUTION:

Before removing the fuel pressure gauge, release the fuel pressure.

#### NOTE:

If out of specification, check or replace the pressure regulator and pressure regulator vacuum hose.

1) Release the fuel pressure. <Ref. to FU(STI)-44, RELEASING OF FUEL PRESSURE, PROCEDURE, Fuel.>

2) Open the fuel filler flap lid, and then remove the fuel filler cap.

3) Disconnect the fuel delivery hoses, and then connect the fuel pressure gauge.

4) Connect the connector of fuel pump relay.

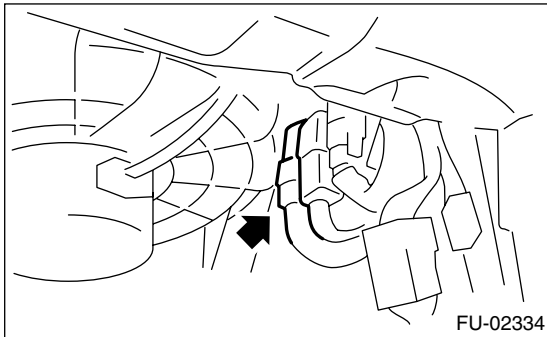

5) Start the engine.

6) Measure the fuel pressure while disconnecting the pressure regulator vacuum hose from intake manifold.

#### Fuel pressure:

**Standard: 284 — 314 kPa (2.9 — 3.2 kgf/cm<sup>2</sup>, 41 — 46 psi)**

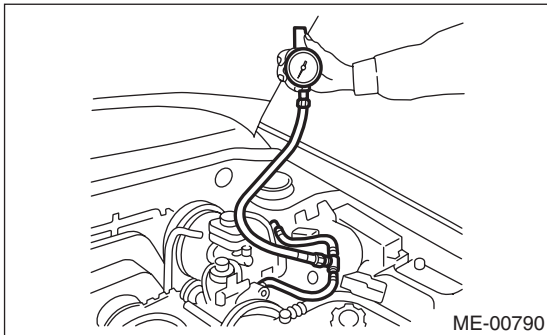

7) After connecting the pressure regulator vacuum hose, measure the fuel pressure.

#### Fuel pressure:

**Standard: 230 — 260 kPa (2.35 — 2.65 kgf/cm<sup>2</sup>, 33 — 38 psi)**

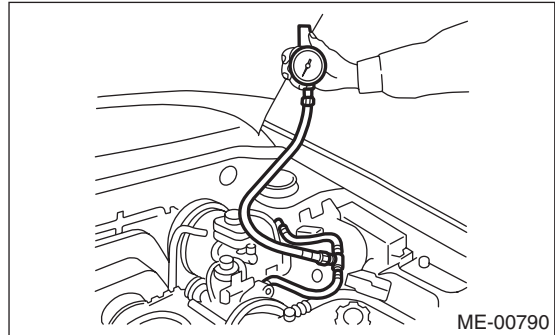

#### NOTE:

The fuel pressure gauge registers 10 to 20 kPa (0.1 to 0.2 kgf/cm<sup>2</sup>, 1 to 3 psi) higher than standard values during high-altitude operations.

## 8. Valve Clearance

### A: INSPECTION

Inspection and adjustment of the valve clearance should be performed while engine is cold.

- 1) Set the vehicle on a lift.
- 2) Disconnect the ground cable from battery.
- 3) Remove the air intake duct. <Ref. to IN(H4DOTC)-9, REMOVAL, Air Intake Duct.>
- 4) Remove the bolts which secure the timing belt cover (RH).
- 5) Lift-up the vehicle.
- 6) Remove the under cover.
- 7) Loosen the remaining bolts which secure the timing belt cover (RH), and then remove the timing belt cover.
- 8) Lower the vehicle.
- 9) When inspecting the #1 and #3 cylinders:
  - (1) Pull out the engine harness connector with bracket from air cleaner upper cover.

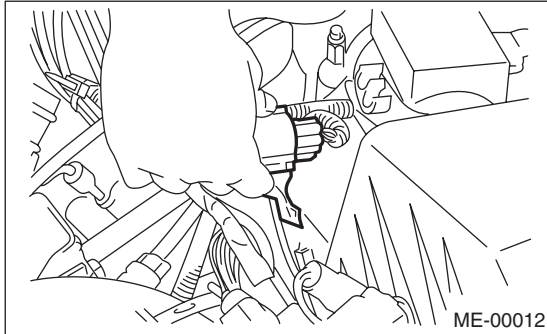

- (2) Remove the air cleaner case. <Ref. to IN(H4DOTC)-8, REMOVAL, Air Cleaner Case.>
  - (3) Disconnect the ignition coil connector.
  - (4) Remove the ignition coil.
  - (5) Place a suitable container under the vehicle.
  - (6) Disconnect the PCV hose from rocker cover (RH).
  - (7) Remove the bolts, and then remove the rocker cover (RH).
- 10) When inspecting the #2 and #4 cylinders:
    - (1) Disconnect the battery cable, and then remove the battery and battery carrier.
    - (2) Disconnect the ignition coil connector.
    - (3) Remove the ignition coil.
    - (4) Place a suitable container under the vehicle.
    - (5) Disconnect the PCV hose from rocker cover (LH).
    - (6) Remove the bolts, and then remove the rocker cover (LH).
  - 11) Turn the crank pulley clockwise until arrow mark on the cam sprocket is set to position shown in the figure.

NOTE:

Turn the crankshaft using socket wrench.

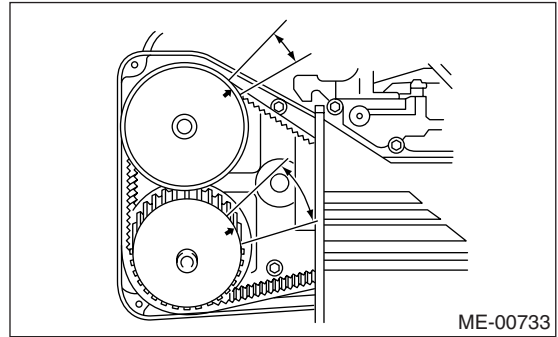

- 12) Measure the #1 cylinder intake valve and #3 cylinder exhaust valve clearance by using thickness gauge (A).

NOTE:

- Insert the thickness gauge (A) as horizontally as possible with respect to the shim.
- Measure the exhaust valve clearances while lifting-up the vehicle.

**Valve clearance:**

**Intake:  $0.20 \pm 0.02$  mm ( $0.0079 \pm 0.0008$  in)**

**Exhaust:  $0.35 \pm 0.02$  mm ( $0.0138 \pm 0.0008$  in)**

NOTE:

If the measured value is not within specification, take notes of the value in order to adjust the valve clearance later on.

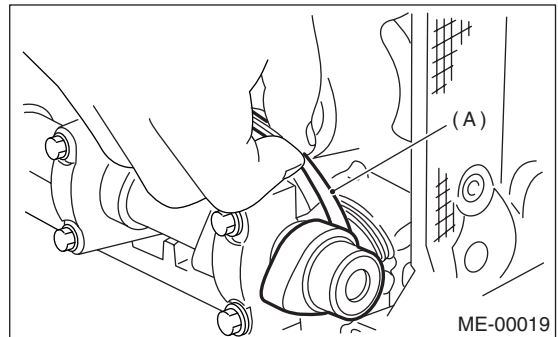

- 13) If necessary, adjust the valve clearance. <Ref. to ME(STI)-28, ADJUSTMENT, Valve Clearance.>
- 14) Further turn the crank pulley clockwise. Using the same procedures described previously, measure the valve clearances again.

# Valve Clearance

## MECHANICAL

(1) Set the arrow mark on cam sprocket to position shown in the figure, and then measure the #2 cylinder exhaust valve and #3 cylinder intake valve clearances.

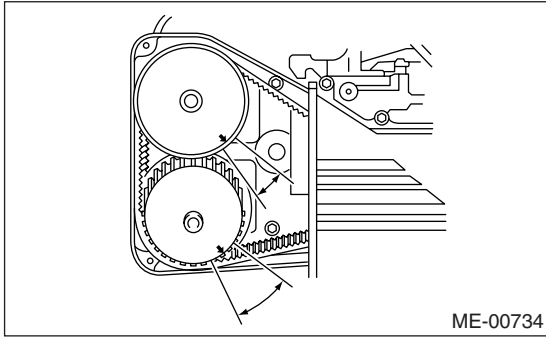

(2) Set the arrow mark on cam sprocket to position shown in the figure, and then measure the #2 cylinder intake valve and #4 cylinder exhaust valve clearances.

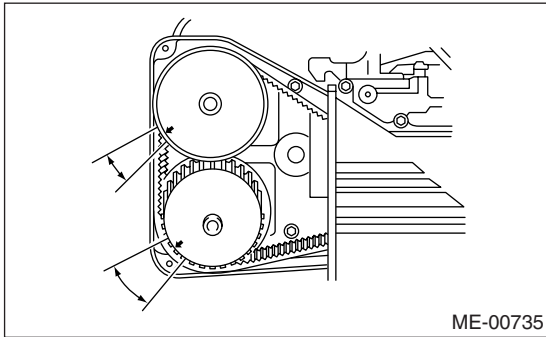

(3) Set the arrow mark on cam sprocket to position shown in the figure, and then measure the #1 cylinder exhaust valve and #4 cylinder intake valve clearances.

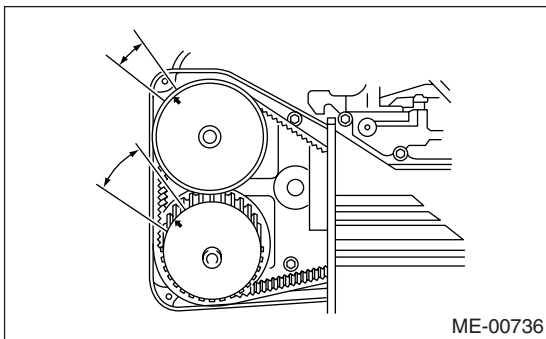

15) After inspection, install the related parts in the reverse order of removal.

**Tightening torque:**  
**33 N·m (3.4 kgf·m, 25 ft·lb)**

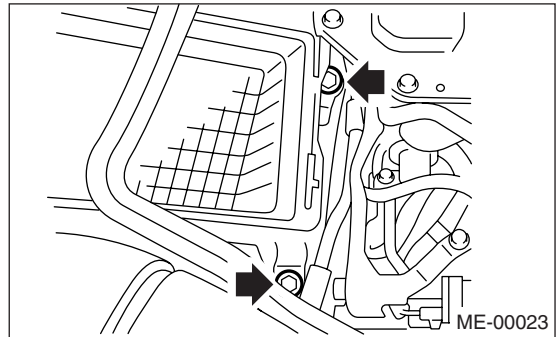

## B: ADJUSTMENT

### CAUTION:

**Adjustment of the valve clearance should be performed while engine is cold.**

1) Measure all valve clearances. <Ref. to ME(STI)-27, INSPECTION, Valve Clearance.>

### NOTE:

Record each valve clearance after it has been measured.

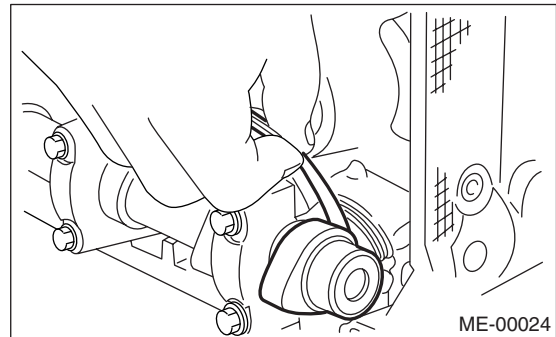

2) Remove the camshaft. <Ref. to ME(STI)-54, REMOVAL, Camshaft.>

3) Remove the valve lifter.

4) Measure the thickness of valve lifter with a micrometer.

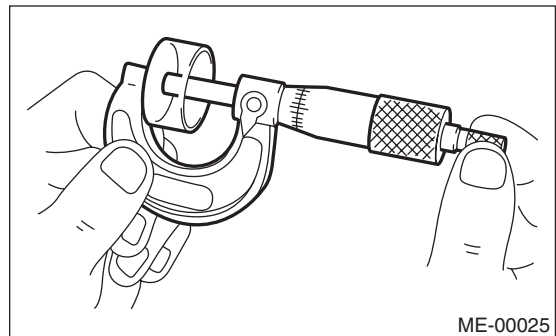

5) Select a valve lifter of suitable thickness using measured valve clearance and valve lifter thickness, by referring to the following table.

# Valve Clearance

MECHANICAL

Unit: mm
Intake valve: $S = (V + T) - 0.20$
Exhaust valve: $S = (V + T) - 0.35$
S: Required thickness of valve lifter
V: Measured valve clearance
T: Used valve lifter thickness

Part No.	Thickness mm (in)
13228 AB102	4.68 (0.1843)
13228 AB112	4.69 (0.1846)
13228 AB122	4.70 (0.1850)
13228 AB132	4.71 (0.1854)
13228 AB142	4.72 (0.1858)
13228 AB152	4.73 (0.1862)
13228 AB162	4.74 (0.1866)
13228 AB172	4.75 (0.1870)
13228 AB182	4.76 (0.1874)
13228 AB192	4.77 (0.1878)
13228 AB202	4.78 (0.1882)
13228 AB212	4.79 (0.1886)
13228 AB222	4.80 (0.1890)
13228 AB232	4.81 (0.1894)
13228 AB242	4.82 (0.1898)
13228 AB252	4.83 (0.1902)
13228 AB262	4.84 (0.1906)
13228 AB272	4.85 (0.1909)
13228 AB282	4.86 (0.1913)
13228 AB292	4.87 (0.1917)
13228 AB302	4.88 (0.1921)
13228 AB312	4.89 (0.1925)
13228 AB322	4.90 (0.1929)
13228 AB332	4.91 (0.1933)
13228 AB342	4.92 (0.1937)
13228 AB352	4.93 (0.1941)
13228 AB362	4.94 (0.1945)
13228 AB372	4.95 (0.1949)
13228 AB382	4.96 (0.1953)
13228 AB392	4.97 (0.1957)
13228 AB402	4.98 (0.1961)
13228 AB412	4.99 (0.1965)
13228 AB422	5.00 (0.1969)
13228 AB432	5.01 (0.1972)
13228 AB442	5.02 (0.1976)
13228 AB452	5.03 (0.1980)
13228 AB462	5.04 (0.1984)
13228 AB472	5.05 (0.1988)
13228 AB482	5.06 (0.1992)
13228 AB492	5.07 (0.1996)
13228 AB502	5.08 (0.2000)
13228 AB512	5.09 (0.2004)
13228 AB522	5.10 (0.2008)
13228 AB532	5.11 (0.2012)

Part No.	Thickness mm (in)
13228 AB542	5.12 (0.2016)
13228 AB552	5.13 (0.2020)
13228 AB562	5.14 (0.2024)
13228 AB572	5.15 (0.2028)
13228 AB582	5.16 (0.2031)
13228 AB592	5.17 (0.2035)
13228 AB602	5.18 (0.2039)
13228 AB612	5.19 (0.2043)
13228 AB622	5.20 (0.2047)
13228 AB632	5.21 (0.2051)
13228 AB642	5.22 (0.2055)
13228 AB652	5.23 (0.2059)
13228 AB662	5.24 (0.2063)
13228 AB672	5.25 (0.2067)
13228 AB682	5.26 (0.2071)
13228 AB692	5.27 (0.2075)
13228 AB702	4.38 (0.1724)
13228 AB712	4.40 (0.1732)
13228 AB722	4.42 (0.1740)
13228 AB732	4.44 (0.1748)
13228 AB742	4.46 (0.1756)
13228 AB752	4.48 (0.1764)
13228 AB762	4.50 (0.1771)
13228 AB772	4.52 (0.1780)
13228 AB782	4.54 (0.1787)
13228 AB792	4.56 (0.1795)
13228 AB802	4.58 (0.1803)
13228 AB812	4.60 (0.1811)
13228 AB822	4.62 (0.1819)
13228 AB832	4.64 (0.1827)
13228 AB842	4.66 (0.1835)
13228 AB852	5.29 (0.2083)
13228 AB862	5.31 (0.2091)
13228 AB872	5.33 (0.2098)
13228 AB882	5.35 (0.2106)
13228 AB892	5.37 (0.2114)
13228 AB902	5.39 (0.2122)
13228 AB912	5.41 (0.2123)
13228 AB922	5.43 (0.2138)
13228 AB932	5.45 (0.2146)
13228 AB942	5.47 (0.2154)
13228 AB952	5.49 (0.2161)
13228 AB962	5.51 (0.2169)
13228 AB972	5.53 (0.2177)
13228 AB982	5.55 (0.2185)
13228 AB992	5.57 (0.2193)
13228 AC002	5.59 (0.2201)
13228 AC012	5.61 (0.2209)
13228 AC022	5.63 (0.2217)
13228 AC032	5.65 (0.2224)

## Valve Clearance

### MECHANICAL

---

- 6) Inspect all valves for clearance again at this stage. If the valve clearance is not correct, repeat the procedure over again from the first step.
- 7) After inspection, install the related parts in the reverse order of removal.

## 9. Engine Assembly

### A: REMOVAL

- 1) Set the vehicle on a lift.
- 2) Open the front hood fully, and then support with the hood stay.
- 3) Collect the refrigerant from A/C system.
- 4) Release the fuel pressure.
  - (1) Disconnect the fuel pump relay connector.

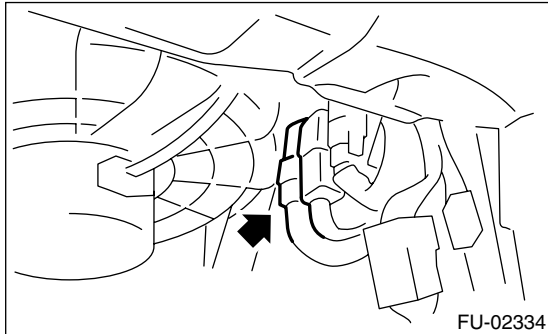

- (2) Start the engine, and run until it stalls.
- (3) After the engine stalls, crank it for 5 seconds more.
- (4) Turn the ignition switch to OFF.
- 5) Remove the fuel filler cap.
- 6) Disconnect the ground cable from battery.
- 7) Remove the radiator from vehicle. <Ref. to CO(H4DOTC)-23, REMOVAL, Radiator.>
- 8) Remove the coolant filler tank. <Ref. to CO(H4DOTC)-33, REMOVAL, Coolant Filler Tank.>
- 9) Disconnect the A/C pressure hoses from A/C compressor.

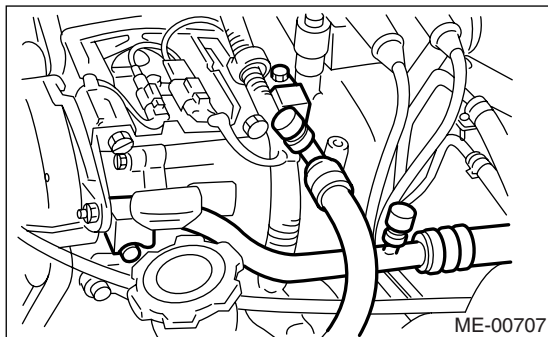

- 10) Remove the intercooler. <Ref. to IN(STI)-11, REMOVAL, Intercooler.>
- 11) Disconnect the following connectors and cable.

- (1) Engine harness connector

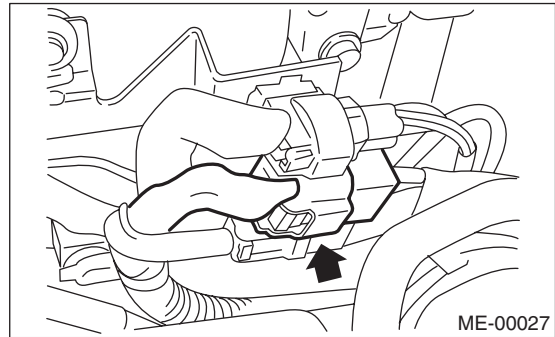

- (2) Engine ground terminal

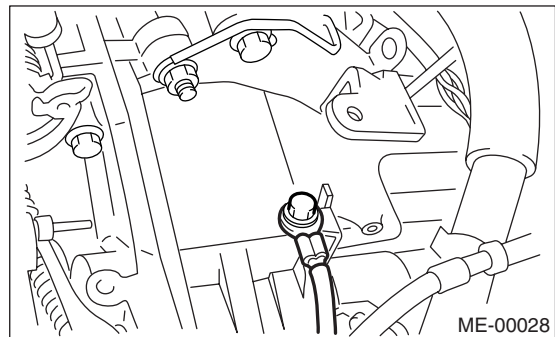

- (3) Engine harness connector

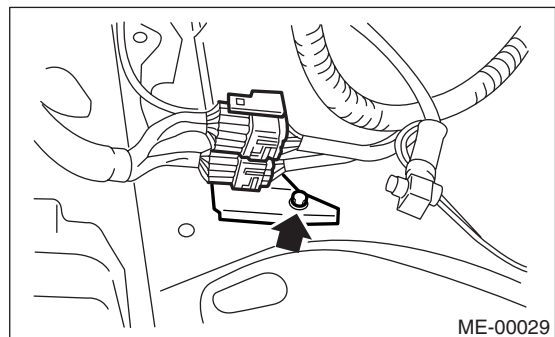

- (4) Generator connector, terminal and A/C compressor connectors

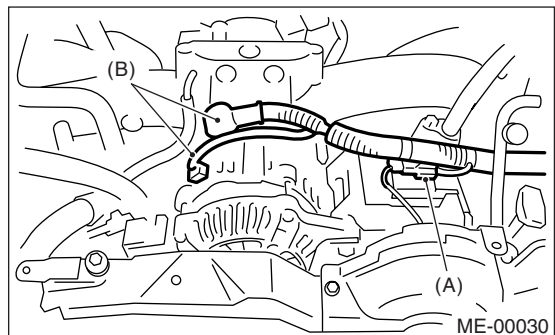

- (A) A/C compressor connector
- (B) Generator connector and terminal



# Engine Assembly

## MECHANICAL

(5) Clutch release spring

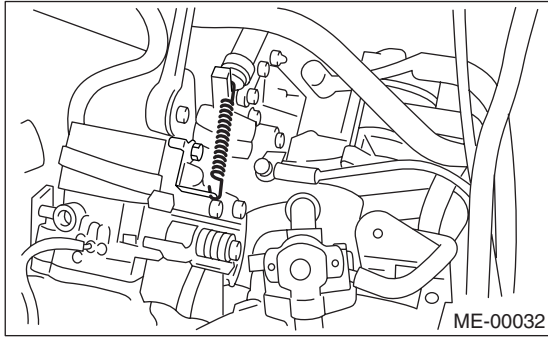

12) Disconnect the following hoses.

(1) Brake booster vacuum hose

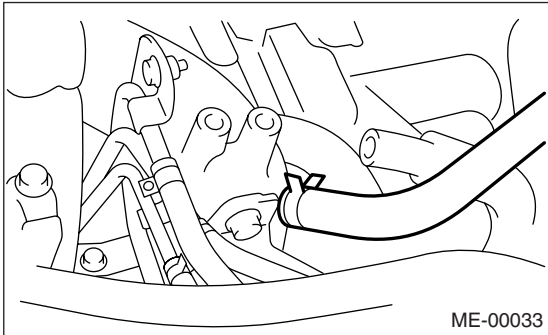

(2) Heater inlet outlet hose

13) Remove the power steering pump from bracket.

(1) Loosen the lock bolt and slider bolt, and then remove the front side V-belt. <Ref. to ME(STI)-40, FRONT SIDE BELT, REMOVAL, V-belt.>

(2) Disconnect the power steering switch connector.

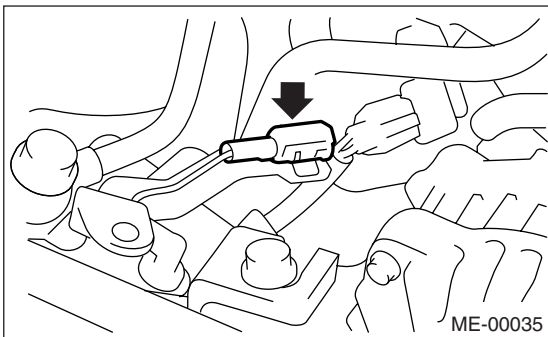

(3) Remove the pipe with bracket from intake manifold.

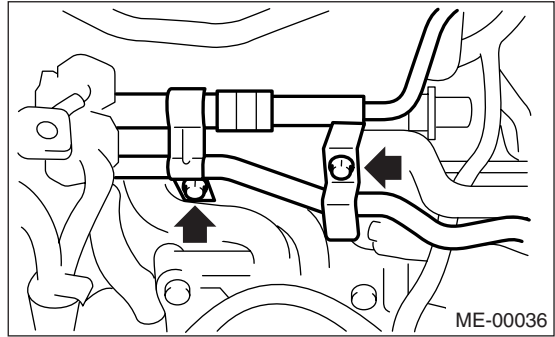

(4) Remove the power steering pump from engine.

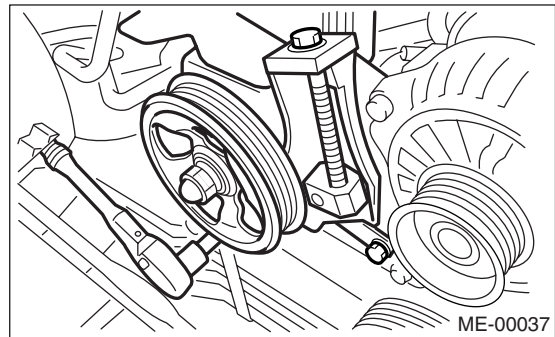

(5) Remove the power steering tank from bracket by pulling it upward.

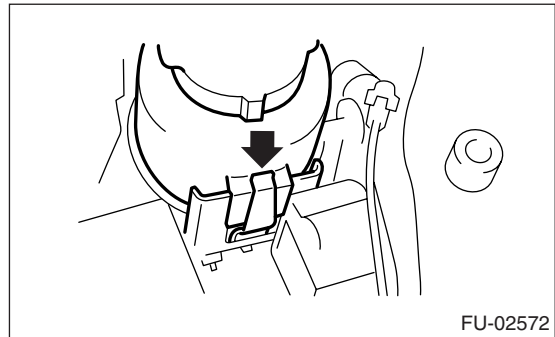

(6) Place the power steering pump on right side wheel apron.

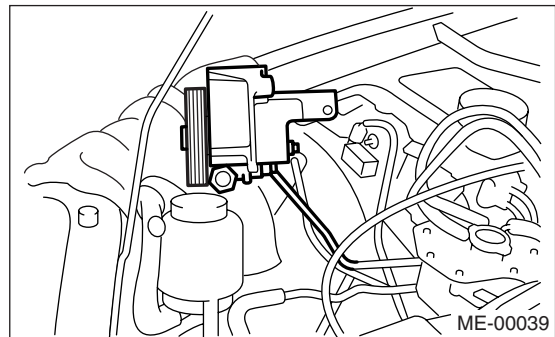

14) Lift-up the vehicle.

15) Remove the center exhaust pipe. <Ref. to EX(H4DOTC)-10, REMOVAL, Center Exhaust Pipe.>



16) Remove the nuts which hold the lower side of transmission to engine.

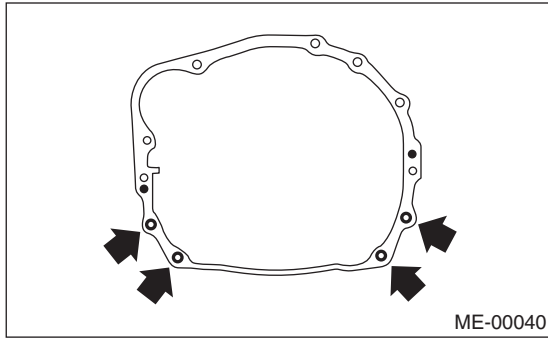

17) Remove the nuts which install the front cushion rubber onto front crossmember.

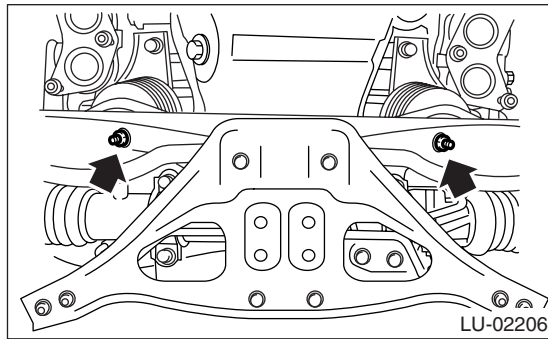

18) Lower the vehicle.

19) Separate the clutch release fork from release bearing.

- (1) Remove the clutch operating cylinder from transmission.
- (2) Remove the plug using a 10 mm hexagon wrench.

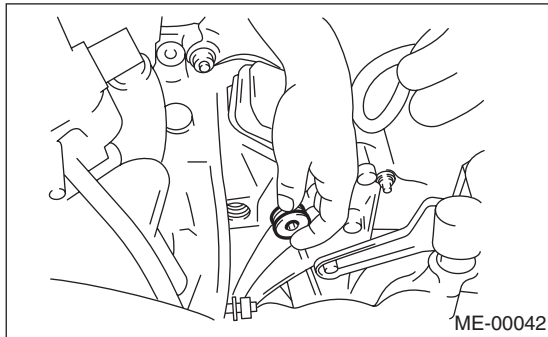

(3) Screw the 6 mm dia. bolt into release fork shaft, and remove it.

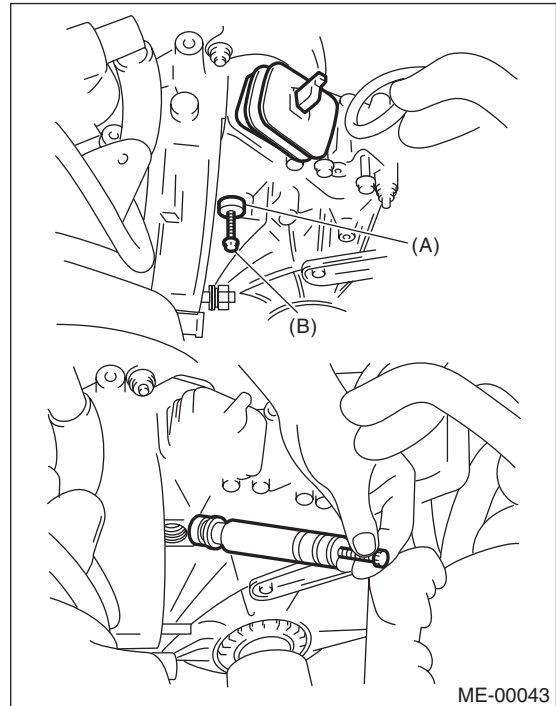

- (A) Shaft  
(B) Bolt

(4) Raise the release fork, and then unfasten the release bearing tabs to free release fork.

**NOTE:**

Step (4) is required to prevent interference with engine when removing the engine from transmission.

20) Remove the pitching stopper.

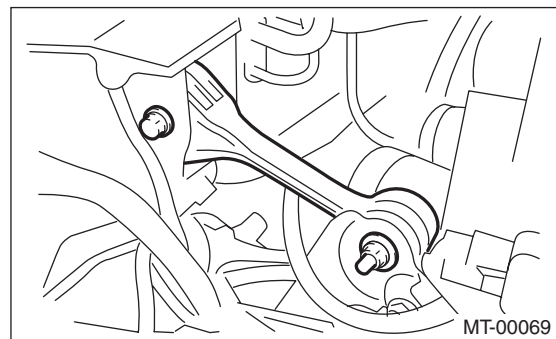

21) Disconnect the fuel delivery hose (A), return hose (B) and evaporation hose (C).

**NOTE:**

- Catch fuel from the hose into container.
- Disconnect the hose with its end wrapped with cloth to prevent fuel from splashing.

# Engine Assembly

MECHANICAL

## ST 42099AE000 CONNECTOR REMOVER

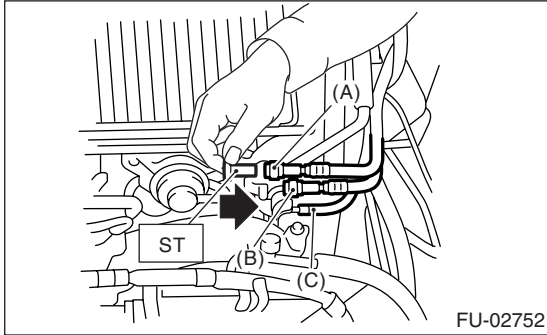

22) Support the engine with a lifting device and wire ropes.

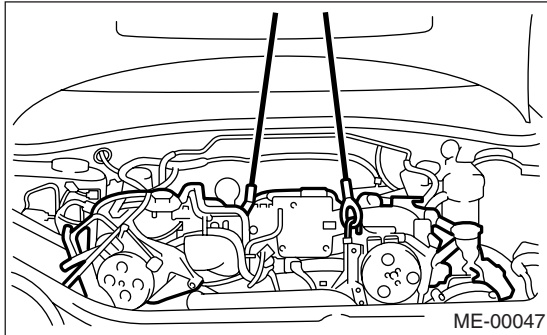

23) Support the transmission with a garage jack.

### CAUTION:

Doing this is very important in order to facilitate re-installation and because transmission lowers under its own weight.

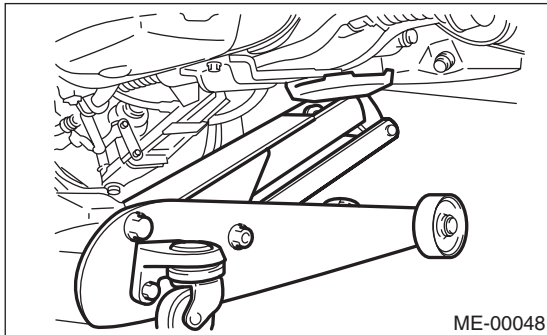

### CAUTION:

Before removing the engine away from transmission, check to be sure no work has been overlooked.

24) Separation of the engine and transmission

- (1) Remove the starter. <Ref. to SC(H4SO)-8, REMOVAL, Starter.>
- (2) Remove the bolts which hold the right upper side of transmission to engine.

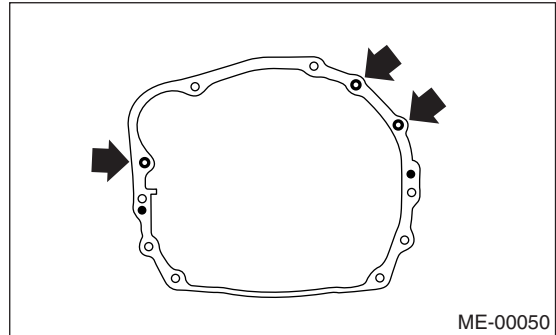

25) Remove the engine from vehicle.

- (1) Slightly raise the engine.
- (2) Raise the transmission with garage jack.
- (3) Move the engine horizontally until the mainshaft is withdrawn from clutch cover.
- (4) Slowly move the engine away from engine compartment.

### NOTE:

Be careful not to damage adjacent parts or body panels with crank pulley, oil pressure gauge, etc.

26) Remove the front cushion rubbers.

## B: INSTALLATION

1) Install the clutch release fork and bearing onto transmission.

- (1) Remove the release bearing from clutch cover with flat-tip screwdriver.

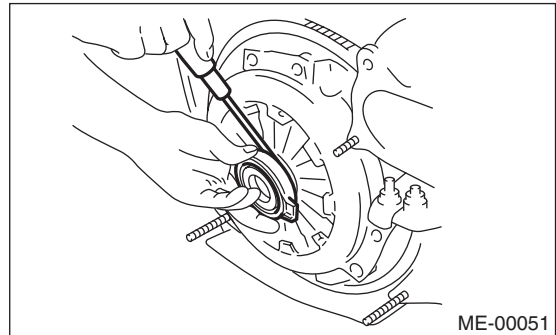

- (2) Install the release bearing on transmission.

(3) Install the release fork into release bearing tab.

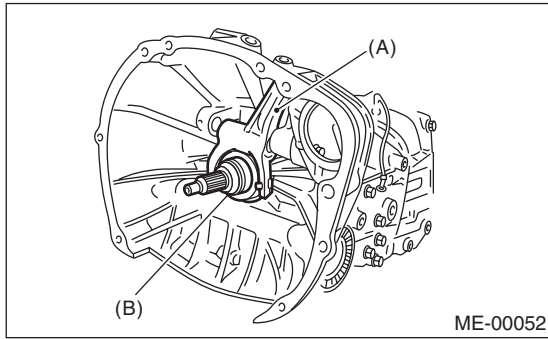

- (A) Release fork
- (B) Release bearing

(4) Apply grease to the specified points.  
 • Spline NICHIMOLY 130

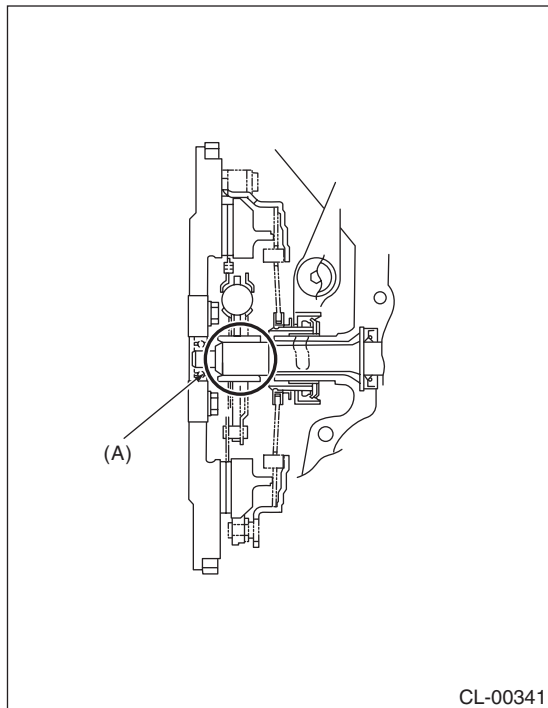

- (A) Spline

(5) Insert the release fork shaft into release fork.

**CAUTION:**  
 Make sure the cutout portion of release fork shaft contacts spring pin.

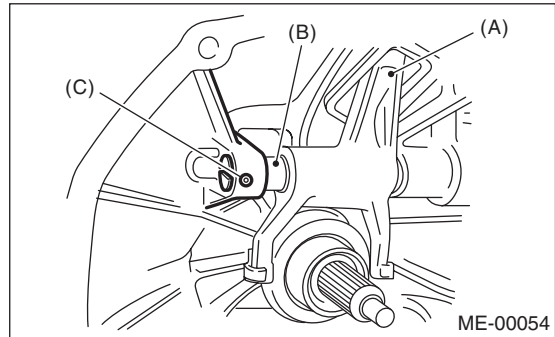

- (A) Release fork
- (B) Release shaft
- (C) Spring pin

(6) Tighten the plug.

**Tightening torque:**  
**44 N·m (4.5 kgf-m, 33.5 ft-lb)**

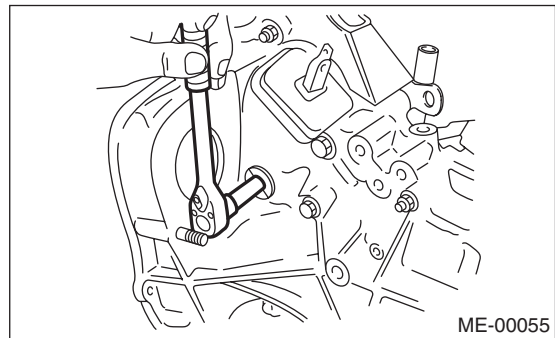

2) Install the front cushion rubbers to engine.

**Tightening torque:**  
**35 N·m (3.6 kgf-m, 25.8 ft-lb)**

3) Install the engine onto transmission.

(1) Position the engine in engine compartment, and then align it with the transmission.

**NOTE:**

Be careful not to damage the adjacent parts or body panels with crank pulley, oil pressure gauge, etc.

(2) Apply a small amount of grease to the splines of mainshaft.

4) Tighten the bolts which hold the upper side of transmission to engine.

# Engine Assembly

MECHANICAL

**Tightening torque:**

**50 N·m (5.1 kgf·m, 36.9 ft·lb)**

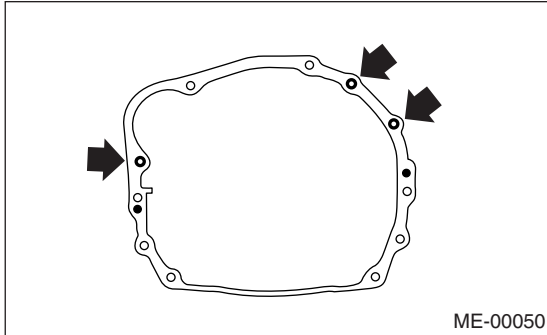

5) Remove the lifting device and wire ropes.

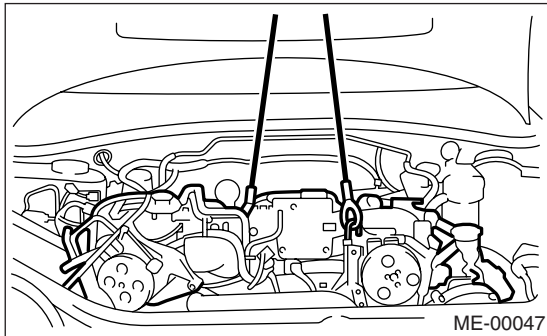

6) Remove the garage jack.

7) Install the pitching stopper.

**Tightening torque:**

**T1: 50 N·m (5.1 kgf·m, 36.9 ft·lb)**

**T2: 58 N·m (5.9 kgf·m, 42.8 ft·lb)**

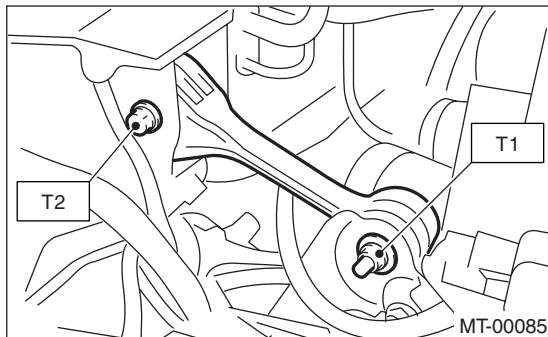

8) Install the power steering pump on bracket.

(1) Install the power steering tank on bracket.

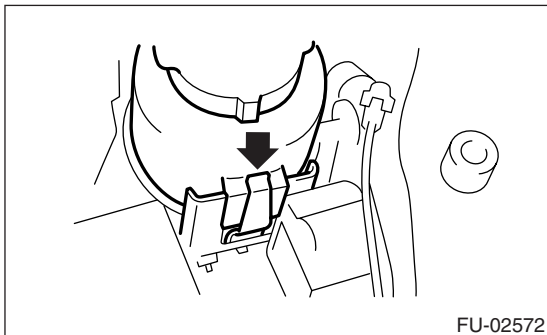

(2) Install the power steering pump.

**Tightening torque:**

**20 N·m (2.0 kgf·m, 14.5 ft·lb)**

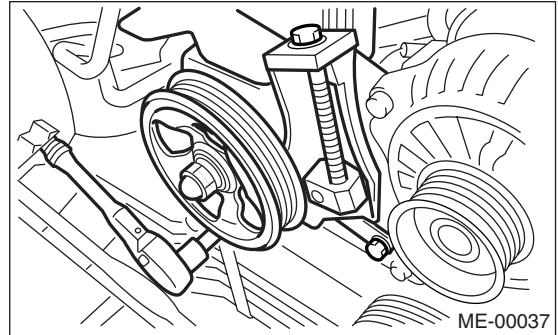

(3) Install the power steering pipe bracket on intake manifold RH.

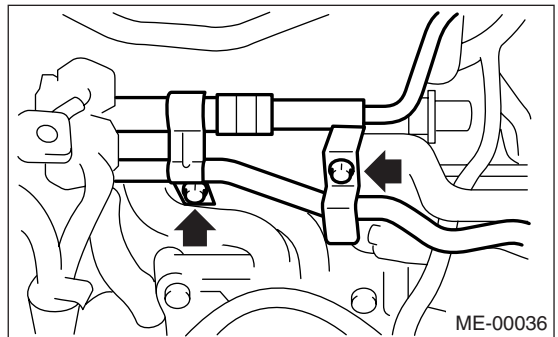

(4) Connect the power steering switch connector.

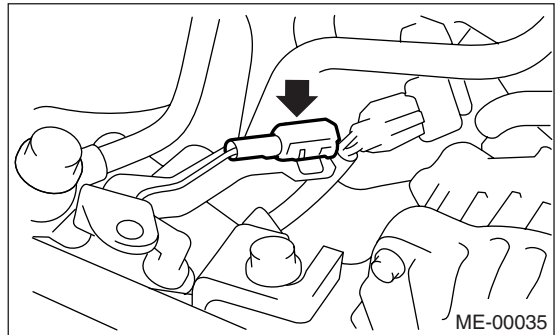

(5) Install the front side V-belt, and adjust it.  
<Ref. to ME(STI)-40, FRONT SIDE BELT, INSTALLATION, V-belt.>

9) Lift-up the vehicle.

10) Tighten the nuts which hold the lower side of transmission to engine.

**Tightening torque:**

**50 N·m (5.1 kgf·m, 36.9 ft-lb)**

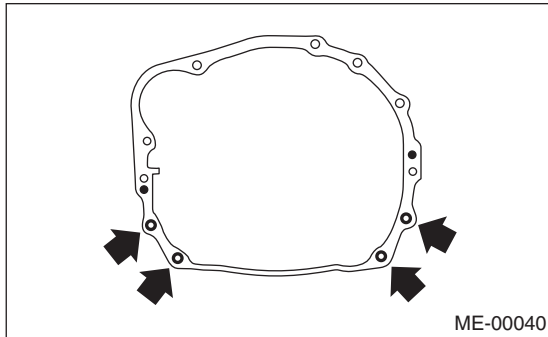

11) Tighten the nuts which install the front cushion rubber onto crossmember.

**Tightening torque:**

**85 N·m (8.7 kgf·m, 62.7 ft-lb)**

**NOTE:**

Make sure the front cushion rubber mounting bolts (A) and locator (B) are securely installed.

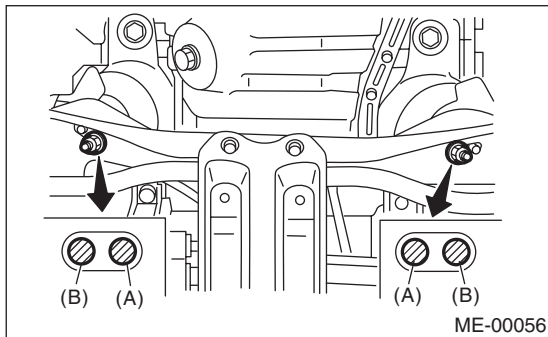

12) Install the center exhaust pipe.  
<Ref. to EX(H4DOTC)-11, INSTALLATION, Center Exhaust Pipe.>

13) Lower the vehicle.

14) Connect the following hoses:

- (1) Fuel delivery hose, return hose and evaporation hose
- (2) Heater inlet and outlet hoses
- (3) Brake booster vacuum hose

15) Connect the following connectors and terminals:

- (1) Engine ground terminal
- (2) Engine harness connectors
- (3) Generator connector and terminal
- (4) A/C compressor connectors

16) Install the air intake system.

- (1) Install the intercooler. <Ref. to IN(STI)-11, INSTALLATION, Intercooler.>
- (2) Install the air cleaner element and air cleaner upper cover.
- (3) Install the engine harness connector bracket.
- (4) Install the filler hose to air cleaner case.

17) Install the A/C pressure hoses.

**NOTE:**

Use new O-rings.

**Tightening torque:**

**25 N·m (2.5 kgf·m, 18.4 ft-lb)**

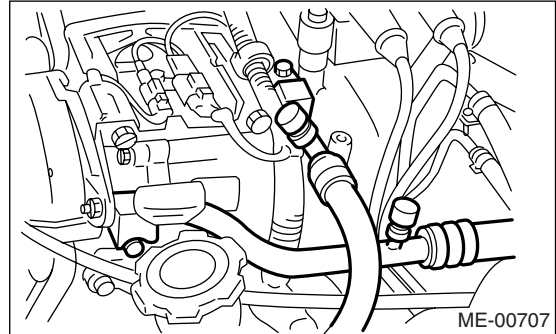

18) Install the radiator. <Ref. to CO(H4DOTC)-24, INSTALLATION, Radiator.>

19) Install the coolant filler tank. <Ref. to CO(H4DOTC)-33, INSTALLATION, Coolant Filler Tank.>

20) Install the window washer tank.

21) Install the battery in the vehicle, and then connect the cables.

22) Fill coolant.

<Ref. to CO(H4DOTC)-17, FILLING OF ENGINE COOLANT, REPLACEMENT, Engine Coolant.>

23) Charge the A/C system with refrigerant.

<Ref. to AC-21, PROCEDURE, Refrigerant Charging Procedure.>

24) Remove the front hood stay, and close the front hood.

25) Take off the vehicle from lift arms.

**C: INSPECTION**

1) Check that the pipes and hoses are installed firmly.

2) Check that the engine coolant is at specified level.

## 10.Engine Mounting

### A: REMOVAL

- 1) Remove the engine assembly. <Ref. to ME(STI)-31, REMOVAL, Engine Assembly.>
- 2) Remove the engine mounting from engine assembly.

### B: INSTALLATION

Install in the reverse order of removal.

#### *Tightening torque:*

#### *Engine mounting;*

*35 N·m (3.6 kgf-m, 25.8 ft-lb)*

### C: INSPECTION

Make sure there are no cracks or other damage.

## 11.Preparation for Overhaul

### A: PROCEDURE

1) After removing the engine from body, secure it in the STs shown below.

ST1	498457000	ENGINE STAND ADAPTER RH
ST2	498457100	ENGINE STAND ADAPTER LH
ST3	499817000	ENGINE STAND

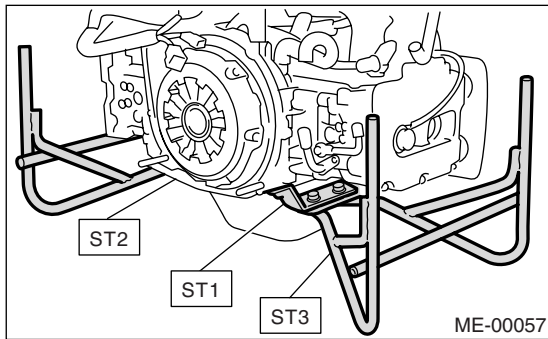

2) In this section the procedures described under each index are all connected and stated in order. It will be the complete procedure for overhauling of the engine itself when you go through all steps in the process.

Therefore, in this section, to conduct the particular procedure within the flow of a section, you need to go back and conduct the procedure described previously in order to do that particular procedure.



## 12.V-belt

### A: REMOVAL

#### 1. FRONT SIDE BELT

- 1) Remove the V-belt cover.

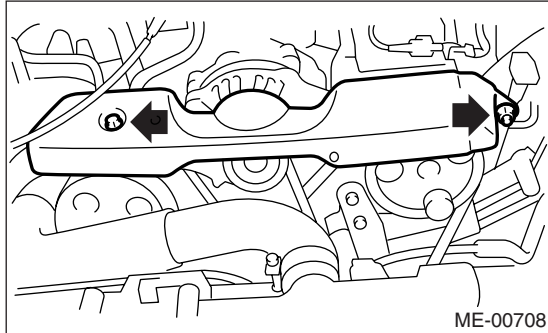

- 2) Loosen the lock bolt (A).
- 3) Loosen the slider bolt (B).
- 4) Remove the front side belt (C).

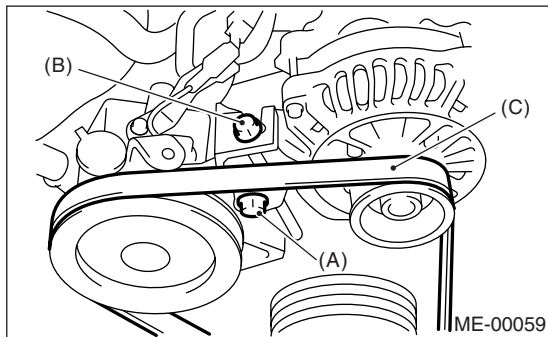

#### 2. REAR SIDE BELT

- 1) Loosen the lock nut (A).
- 2) Loosen the slider bolt (B).

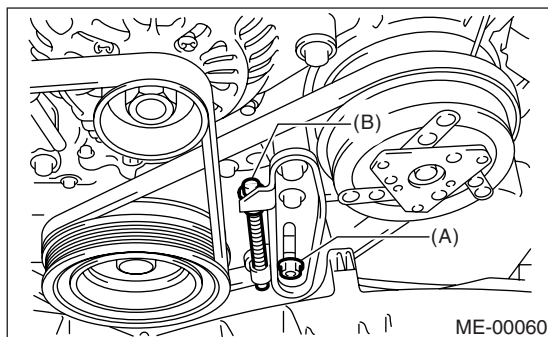

- 3) Remove the A/C belt.

- 4) Remove the A/C belt tensioner.

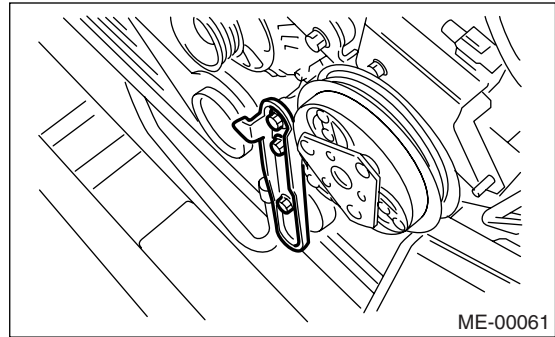

### B: INSTALLATION

#### NOTE:

Wipe off any oil or water on the belt and pulley.

#### 1. FRONT SIDE BELT

- 1) Install the belt (C), and tighten the slider bolt so as to obtain the specified belt tension <Ref. to ME(STI)-41, INSPECTION, V-belt.>
- 2) Tighten the lock bolt (A).
- 3) Tighten the slider bolt (B).

#### Tightening torque:

##### Lock bolt through bolt:

**25 N·m (2.5 kgf-m, 18.4 ft-lb)**

##### Slider bolt:

**8 N·m (0.8 kgf-m, 5.9 ft-lb)**

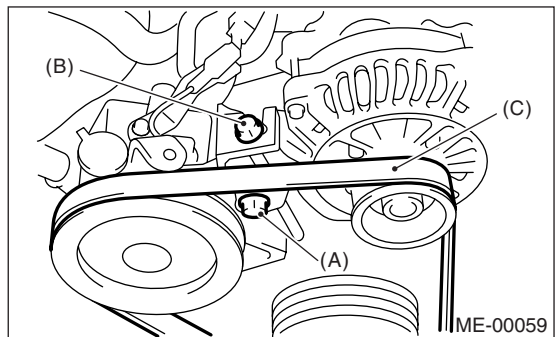

- 4) Idle the engine for approx. 5 min. to normalize the V-belt. (With using tension gauge)
- 5) Stop the engine, and then check the belt tension and adjust it. (With using tension gauge)
- 6) Idle the engine for approx. 1 min. to normalize the V-belt. (With using tension gauge)
- 7) Stop the engine, and then check that the belt tension is within specified value. (With using tension gauge)
- 8) Adjust the belt tension within the specification. (With using tension gauge)



## 2. REAR SIDE BELT

- 1) Install the belt, and tighten the slider bolt (B) so as to obtain the specified belt tension. <Ref. to ME(STI)-41, INSPECTION, V-belt.>
- 2) Tighten the lock nut (A).

### Tightening torque:

**Lock nut (A):**

**23 N·m (2.3 kgf·m, 17.0 ft-lb)**

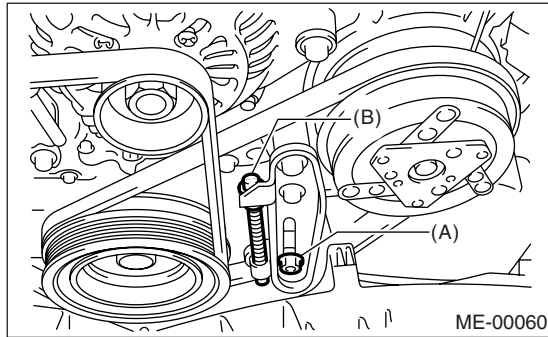

- 3) Idle the engine for approx. 5 min. to normalize the V-belt. (With using tension gauge)
- 4) Stop the engine, and then check the belt tension and adjust it. (With using tension gauge)
- 5) Idle the engine for approx. 1 min. to normalize the V-belt. (With using tension gauge)
- 6) Stop the engine, and then check the belt tension is within specified value. (With using tension gauge)
- 7) Adjust the belt tension within the specification. (With using tension gauge)

## C: INSPECTION

- 1) Replace the belts, if cracks, fraying or wear are found.
- 2) Check the V-belt tension and adjust it if necessary by changing generator installing position and/or idler pulley installing position.

### Belt tension (without using belt tension gauge)

**(A)**

**replaced: 7 — 9 mm (0.276 — 0.354 in)**

**reused: 9 — 11 mm (0.354 — 0.433 in)**

**(B)**

**replaced: 7.5 — 8.5 mm (0.295 — 0.335 in)**

**reused: 9.0 — 10.0 mm (0.354 — 0.394 in)**

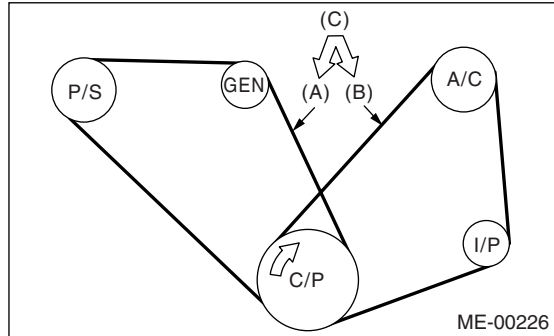

(A) Front side belt

(B) Rear side belt

(C) 98 N (10 kgf, 22 lbf)

C/P Crank pulley

GEN Generator

P/S Power steering oil pump pulley

A/C Air conditioning compressor pulley

I/P Idler pulley

### Belt tension (with using belt tension gauge)

**(A) 490 — 640 N (50 — 65 kgf, 110 — 144 lbf)**

**(B) 350 — 450 N (36 — 46 kgf, 79 — 101 lbf)**

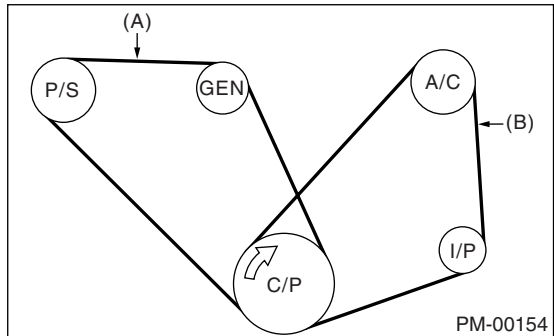

(A) Front side belt

(B) Rear side belt

C/P Crank pulley

GEN Generator

P/S Power steering oil pump pulley

A/C A/C compressor pulley

I/P Idler pulley

## 13.Crank Pulley

### A: REMOVAL

1) Remove the V-belt. <Ref. to ME(STI)-40, REMOVAL, V-belt.>

2) Remove the crank pulley bolt. To lock the crankshaft, use ST.

ST 499977100 CRANK PULLEY WRENCH

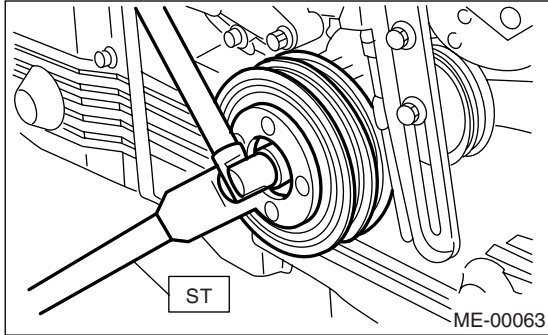

3) Remove the crank pulley.

### B: INSTALLATION

1) Install the crank pulley.

2) Install the pulley bolt.

To lock the crankshaft, use ST.

ST 499977100 CRANK PULLEY WRENCH

(1) Clean the crank pulley thread using an compressed air.

(2) Apply engine oil to the crank pulley bolt seat and thread.

(3) Tighten the bolts temporarily with tightening torque of 44 N·m (4.5 kgf·m, 33 ft·lb).

(4) Tighten the crank pulley bolts.

#### Tightening torque:

**180 N·m (18.4 kgf·m, 132.8 ft·lb)**

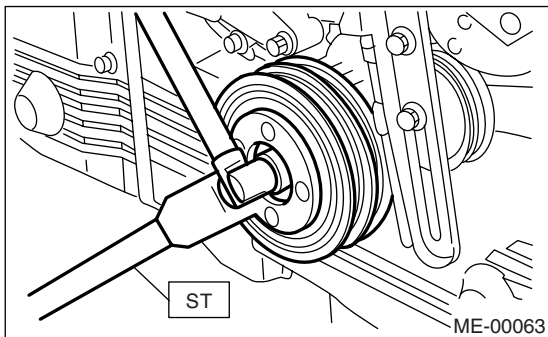

3) Confirm that the tightening angle of crank pulley bolt is 65 degrees or more. If the tightening angle of crank pulley bolt is less than 65 degrees, conduct the following procedures.

#### CAUTION:

**If the tightening angle of crank pulley bolt is less than 65 degrees, the bolt should be damaged. In this case, the bolt must be replaced.**

(1) Replace the crank pulley bolts and clean them.

#### Crank pulley bolt:

**Part No. 12369AA011**

(2) Clean the crankshaft thread using an compressed air.

(3) Apply engine oil to the crank pulley bolt seat and thread.

(4) Tighten the bolts temporarily with tightening torque of 44 N·m (4.5 kgf·m, 33 ft·lb).

(5) Tighten the crank pulley bolts keeping them in an angle between 65 degrees and 75 degrees.

#### NOTE:

Conduct the tightening procedures by confirming the turning angle of crank pulley bolt referring to the gauge indicated on timing belt cover.

4) Install the A/C belt tensioner.

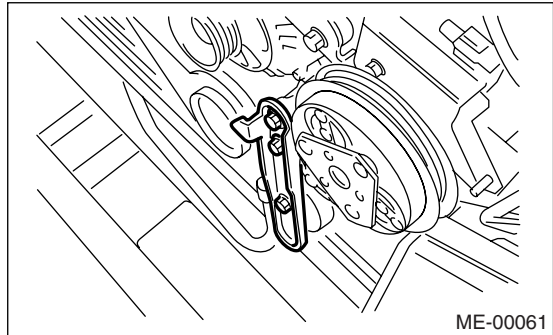

5) Install the V-belt. <Ref. to ME(STI)-40, INSTALLATION, V-belt.>

### C: INSPECTION

1) Make sure the V-belt is not worn or otherwise damaged.

2) Check the tension of the belt. <Ref. to ME(STI)-41, INSPECTION, V-belt.>

## 14. Timing Belt Cover

### A: REMOVAL

- 1) Remove the V-belt. <Ref. to ME(STI)-40, REMOVAL, V-belt.>
- 2) Remove the crank pulley. <Ref. to ME(STI)-42, REMOVAL, Crank Pulley.>
- 3) Remove the timing belt cover (LH) (A).
- 4) Remove the timing belt cover (RH) (B).
- 5) Remove the front timing belt cover (C).

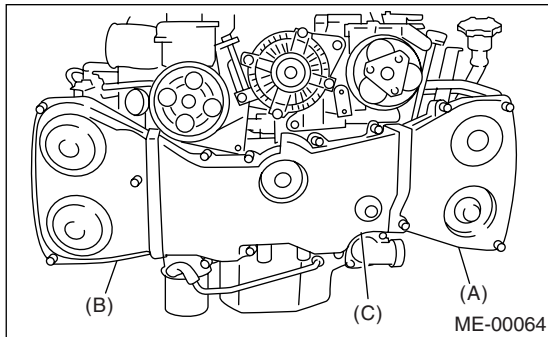

### B: INSTALLATION

- 1) Install the front timing belt cover (C).

**Tightening torque:**

**5 N·m (0.5 kgf-m, 3.6 ft-lb)**

- 2) Install the timing belt cover (RH) (B).

**Tightening torque:**

**5 N·m (0.5 kgf-m, 3.6 ft-lb)**

- 3) Install the timing belt cover (LH) (A).

**Tightening torque:**

**5 N·m (0.5 kgf-m, 3.6 ft-lb)**

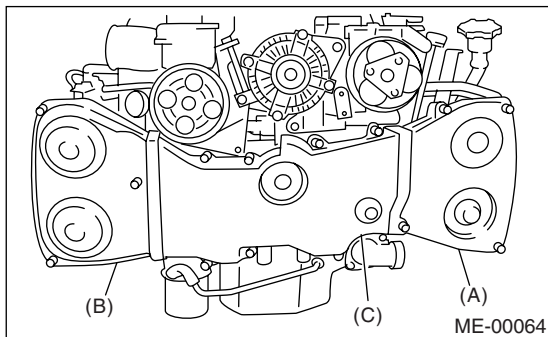

- 4) Install the crank pulley. <Ref. to ME(STI)-42, INSTALLATION, Crank Pulley.>
- 5) Install the V-belt. <Ref. to ME(STI)-40, INSTALLATION, V-belt.>

### C: INSPECTION

Make sure the cover is not damaged.

## 15. Timing Belt

### A: REMOVAL

#### 1. TIMING BELT

- 1) Remove the V-belt. <Ref. to ME(STI)-40, REMOVAL, V-belt.>
- 2) Remove the crank pulley. <Ref. to ME(STI)-42, REMOVAL, Crank Pulley.>
- 3) Remove the timing belt cover. <Ref. to ME(STI)-43, REMOVAL, Timing Belt Cover.>
- 4) Remove the timing belt guides.

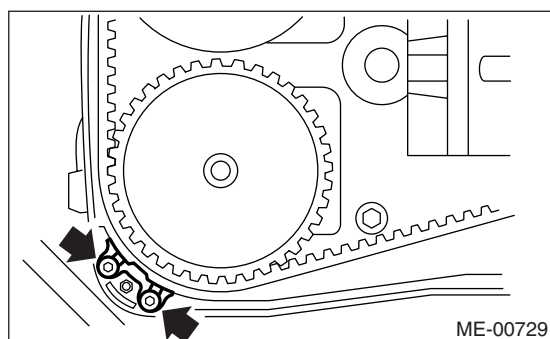
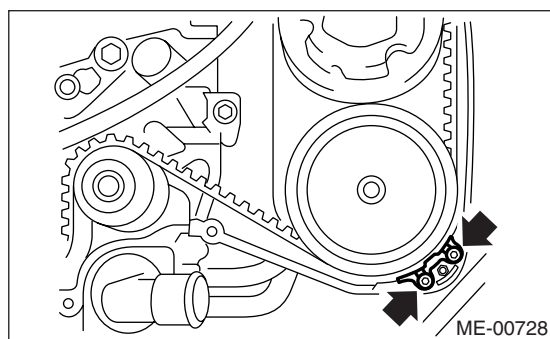
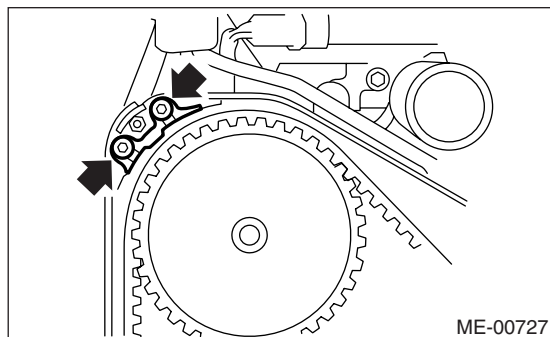
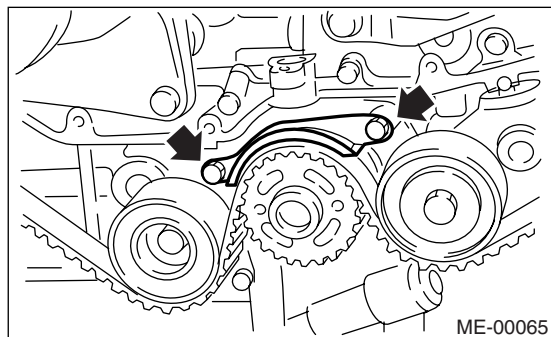

5) If the alignment mark and/or arrow mark (which indicates rotation direction) on timing belt fade away, put new marks before removing the timing belt as follows:

- (1) Turn the crankshaft using ST, and align the alignment marks on crank sprocket, intake cam sprocket (LH), exhaust cam sprocket (LH), intake cam sprocket (RH) and exhaust cam sprocket (RH) with notches of timing belt cover and cylinder block.

ST 499987500 CRANKSHAFT SOCKET

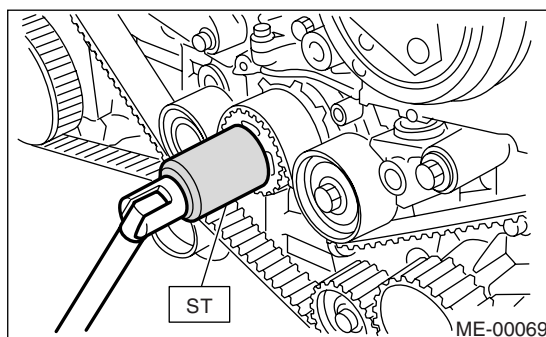

(2) Using white paint, put alignment and/or arrow marks on the timing belts in relation to the sprockets.

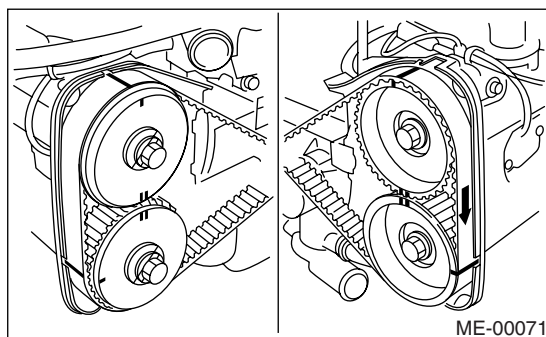
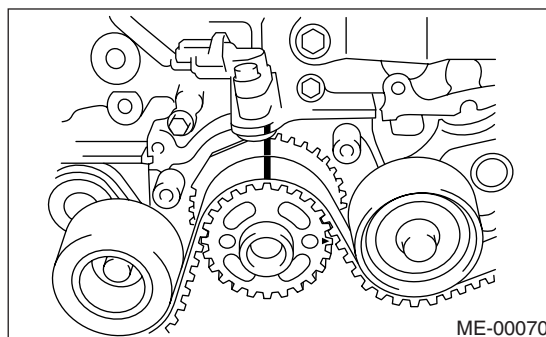

**$Z_1$ : 54.5 tooth length**  
 **$Z_2$ : 51 tooth length**  
 **$Z_3$ : 28 tooth length**

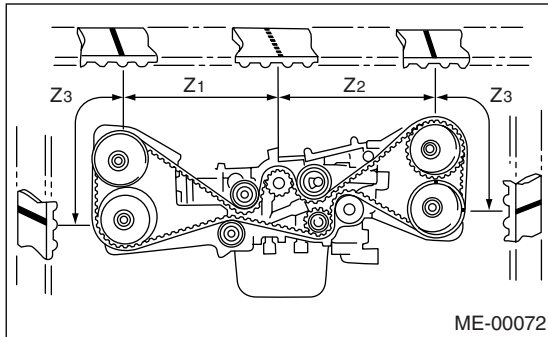

6) Remove the belt idler (A).

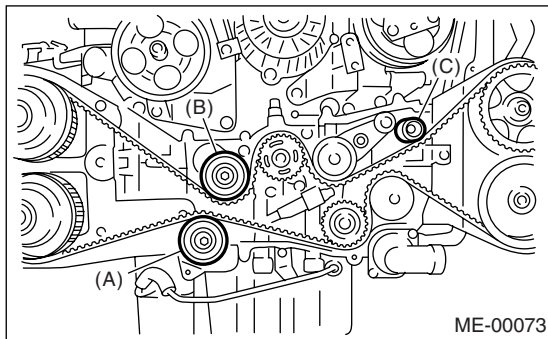

7) Remove the timing belt.

**CAUTION:**

After the timing belt has been removed, never rotate the intake and exhaust cam sprocket. If the cam sprockets are rotated, the intake and exhaust valve heads strike together and valve stems are bent.

**2. BELT IDLER AND AUTOMATIC BELT TENSION ADJUSTER ASSEMBLY**

1) Remove the belt idler (B) and (C).

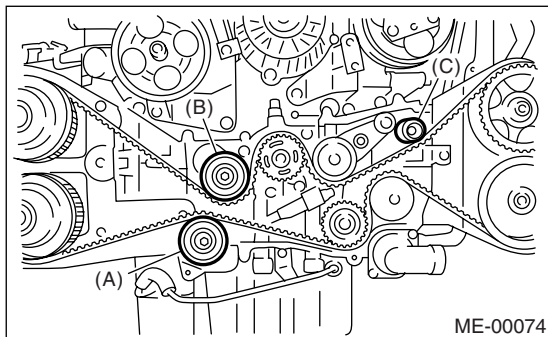

2) Remove the belt idler No. 2.

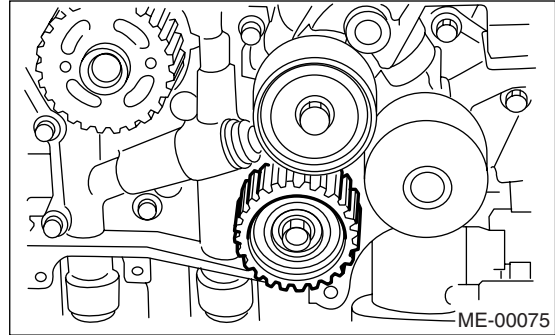

3) Remove the automatic belt tension adjuster assembly.

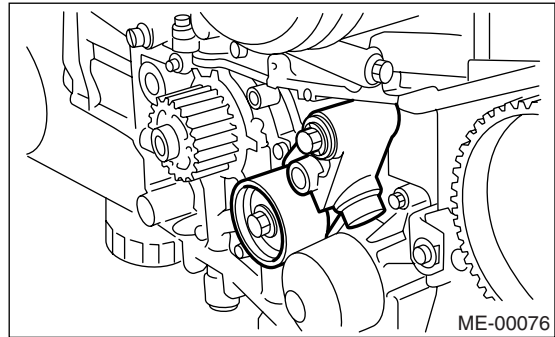

**B: INSTALLATION**

**1. AUTOMATIC BELT TENSION ADJUSTER ASSEMBLY AND BELT IDLER**

1) Preparation for installation of automatic belt tension adjuster assembly:

**CAUTION:**

- Always use a vertical type pressing tool to move the adjuster rod down.
- Do not use a lateral type vise.
- Push the adjuster rod vertically.
- Press-in the push adjuster rod gradually taking more than 3 minutes.
- Do not allow press pressure to exceed 9,807 N (1,000 kgf, 2,205 lbf).
- Press the adjuster rod as far as the end surface of cylinder. Do not press the adjuster rod into the cylinder. Doing so may damage the cylinder.
- Do not release the press pressure until stopper pin is completely inserted.

(1) Attach the automatic belt tension adjuster assembly to the vertical pressing tool.



# Timing Belt

## MECHANICAL

(2) Slowly move the adjuster rod down with a pressure of more than 294 N (30 kgf, 66 lbf) until the adjuster rod is aligned with the stopper pin hole in the cylinder.

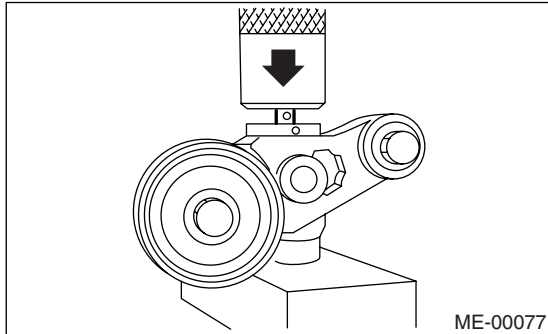

(3) With a 2 mm (0.08 in) dia. stopper pin or a 2 mm (nominal) dia. hex bar wrench inserted into the stopper pin hole in the cylinder, secure the adjuster rod.

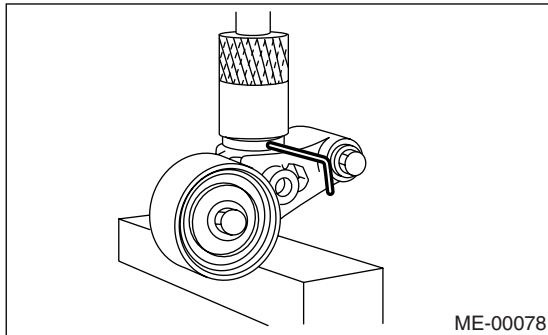

2) Install the automatic belt tension adjuster assembly.

**Tightening torque:**

**39 N·m (4.0 kgf·m, 28.9 ft·lb)**

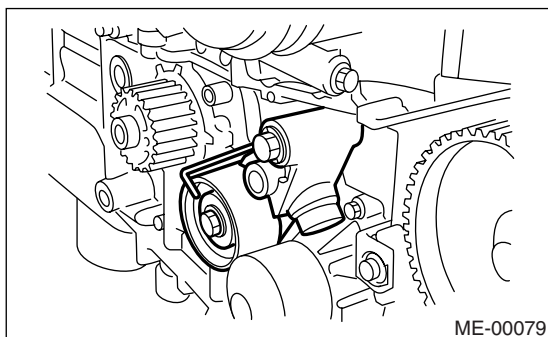

3) Install the belt idler No. 2.

**Tightening torque:**

**39 N·m (4.0 kgf·m, 28.9 ft·lb)**

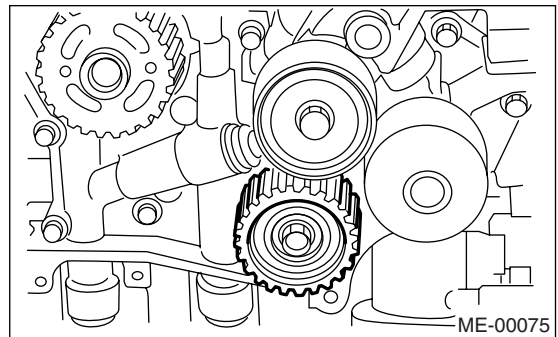

4) Install the belt idler.

**Tightening torque:**

**39 N·m (4.0 kgf·m, 28.9 ft·lb)**

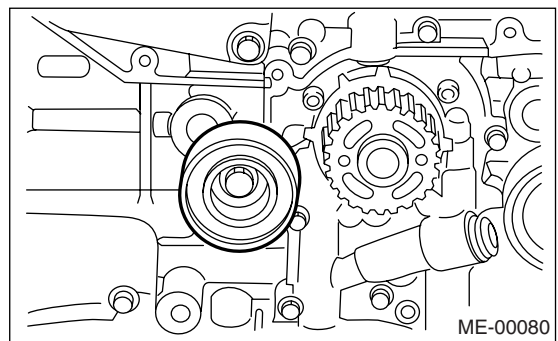

## 2. TIMING BELT

1) Preparation for installation of automatic belt tension adjuster assembly <Ref. to ME(STI)-51, AUTOMATIC BELT TENSION ADJUSTER, INSPECTION, Timing Belt.>

2) Crankshaft and cam sprocket alignment

(1) Align mark (A) on the crank sprocket with mark on the oil pump cover at cylinder block.

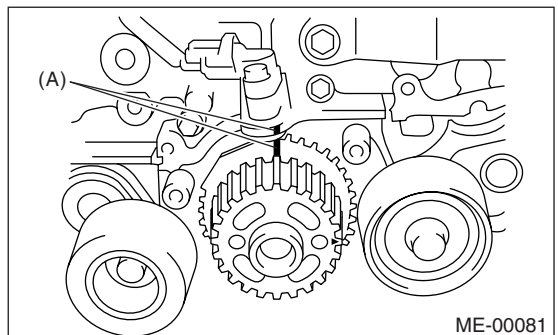

# Timing Belt

MECHANICAL

(2) Align single line mark (A) on the exhaust cam sprocket (RH) with notch (B) on timing belt cover.

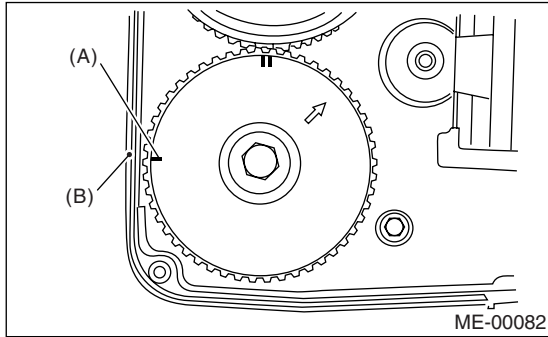

(3) Align single line mark (A) on the intake cam sprocket (RH) with notch (B) on timing belt cover.

(Make sure double lines (C) on intake camshaft and exhaust cam sprockets are aligned.)

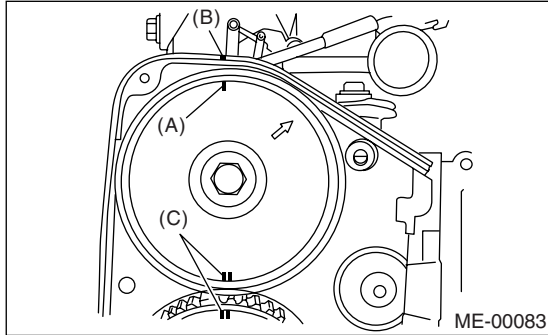

(4) Align single line mark (A) on exhaust cam sprocket (LH) with notch (B) on timing belt cover by turning the sprocket counterclockwise (as viewed from front of engine).

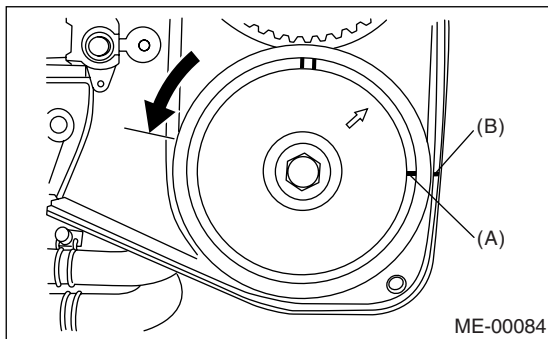

(5) Align the single line mark (A) on intake cam sprocket (LH) with notch (B) on timing belt cover by turning the sprocket clockwise (as viewed from front of engine).

Ensure the double lines (C) on intake and exhaust cam sprockets are aligned.

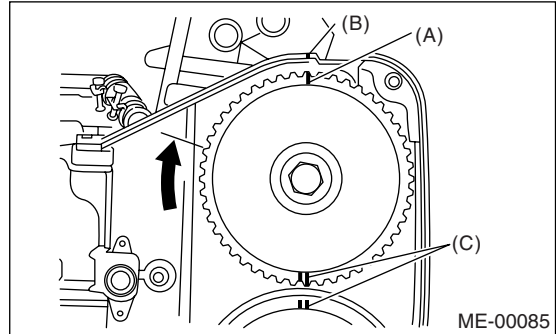

(6) Ensure the camshaft and crank sprockets are positioned properly.

### CAUTION:

- Intake and exhaust camshafts for this DOHC engine can be independently rotated with the timing belts removed. As can be seen from the figure, if the intake and exhaust valves are lifted simultaneously, their heads will interfere with each other, resulting in bent valves.

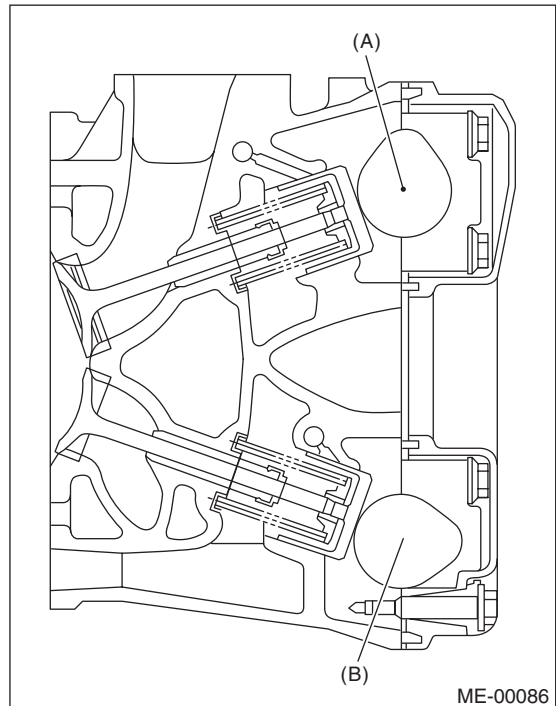

- (A) Intake camshaft
- (B) Exhaust camshaft

# Timing Belt

## MECHANICAL

- When the timing belts are not installed, four camshafts are held at the “zero-lift” position, where all cams on camshafts do not push the intake and exhaust valves down. (Under this condition, all valves remain unlifted.)
- When the camshafts are rotated to install the timing belts, #2 intake and #4 exhaust cam of camshafts (LH) are held to push their corresponding valves down. (Under this condition, these valves are held lifted.) Camshafts (RH) are held so that their cams do not push valves down.
- Camshafts (LH) must be rotated from the “zero-lift” position to the position where the timing belt is to be installed at as small an angle as possible, in order to prevent mutual interference of intake and exhaust valve heads.
- Do not allow the camshafts to rotate in the direction shown by the upper illustration in the figure as this causes both intake and exhaust valves to lift simultaneously, resulting in interference with their heads.

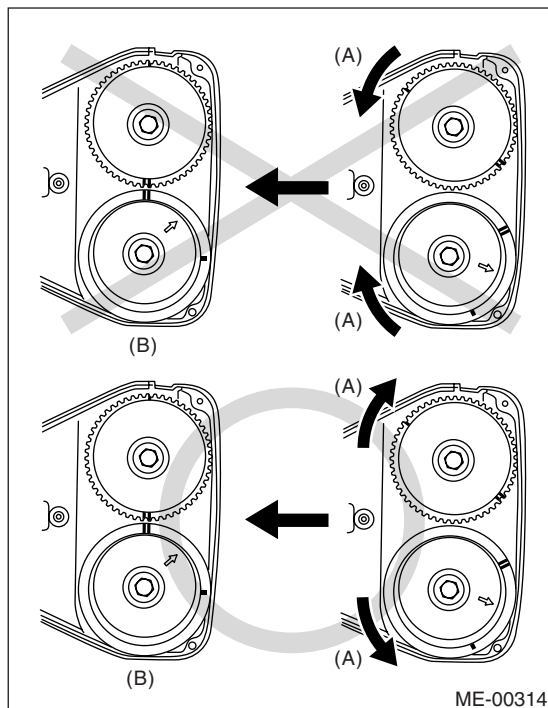

- (A) Rotating direction
- (B) Timing belt installation position



### 3) Installation of timing belt

Align the alignment mark on timing belt with marks on sprockets in alphabetical order shown in the figure. While aligning marks, position the timing belt properly.

**CAUTION:**

- Disengagement of more than three timing belt teeth may result in interference between the valve and piston.
- Ensure the belt's rotating direction is correct.

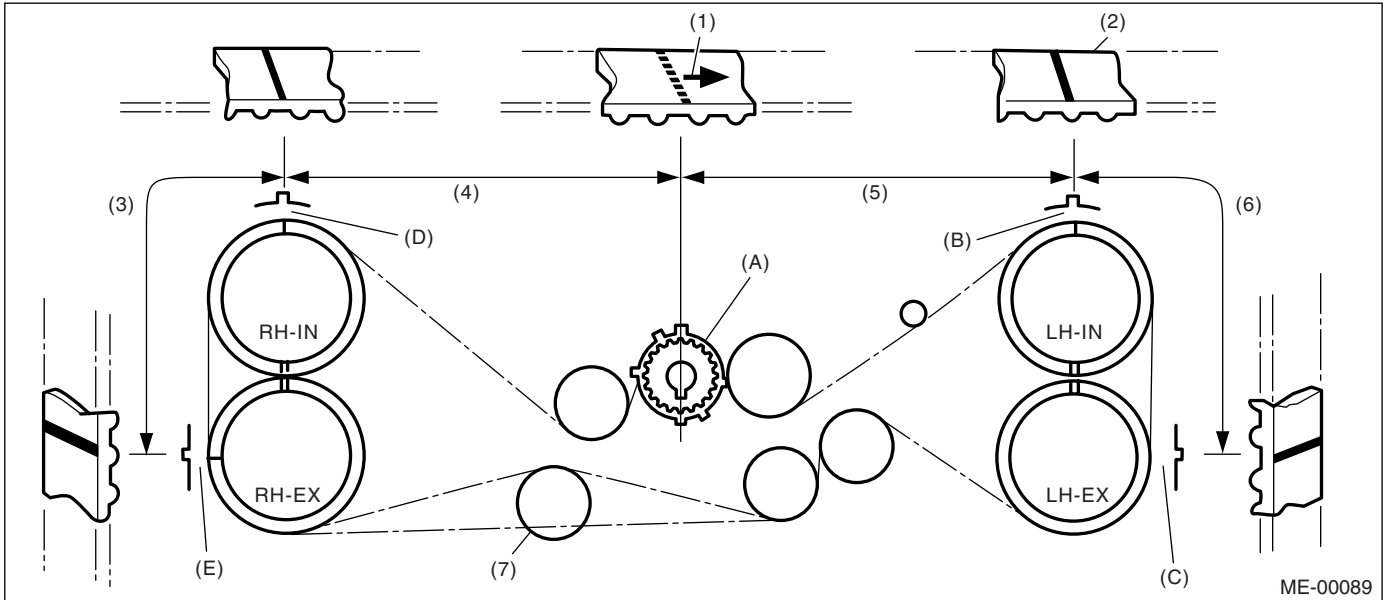

- |                     |                       |                           |
|---------------------|-----------------------|---------------------------|
| (1) Arrow mark      | (4) 54.5 tooth length | (7) Install it in the end |
| (2) Timing belt     | (5) 51 tooth length   |                           |
| (3) 28 tooth length | (6) 28 tooth length   |                           |

### 4) Install the belt idlers.

**Tightening torque:**

**39 N·m (4.0 kgf·m, 28.9 ft·lb)**

**NOTE:**

Make sure that the marks on the timing belt and sprockets are aligned.

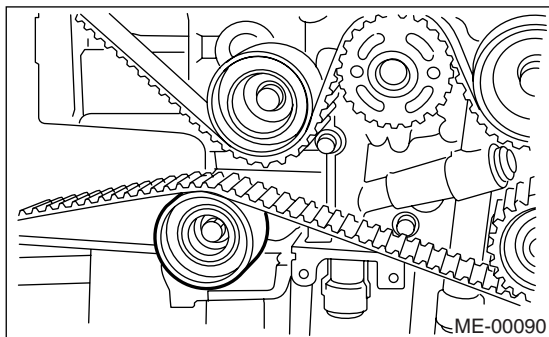

5) After ensuring that the marks on the timing belt and sprockets are aligned, remove the stopper pin from tensioner adjuster.

6) Install the timing belt guide.

**CAUTION:**

- Before installing the bolts, clean the threaded portion of timing belt cover.

- Apply liquid gasket to the threaded portion of bolts. (Cam sprocket side only)

**Liquid gasket:**

**THREE BOND 1324 (Part No. 004403042) or equivalent**

- (1) Temporarily tighten the bolts.
- (2) Check and adjust the clearance between timing belt and timing belt guide.

# Timing Belt

MECHANICAL

## Clearance:

$1.0 \pm 0.5 \text{ mm}$  ( $0.039 \pm 0.020 \text{ in}$ )

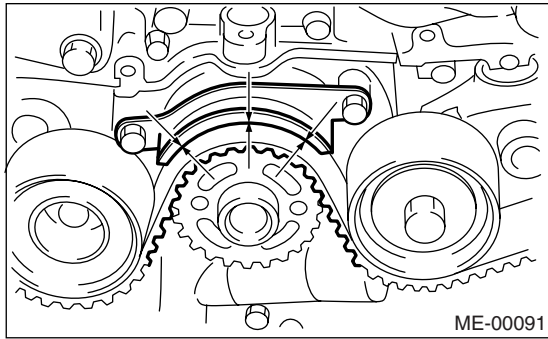

## Tightening torque:

$9.75 \text{ N}\cdot\text{m}$  ( $1.0 \text{ kgf}\cdot\text{m}$ ,  $7 \text{ ft}\cdot\text{lb}$ )

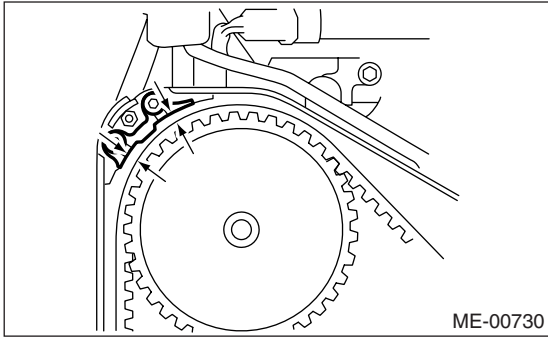
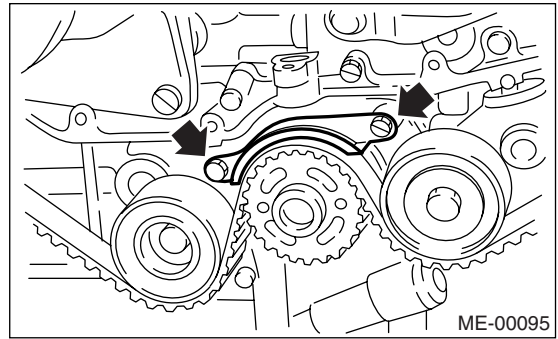

## Tightening torque:

$6.4 \text{ N}\cdot\text{m}$  ( $0.65 \text{ kgf}\cdot\text{m}$ ,  $4.7 \text{ ft}\cdot\text{lb}$ )

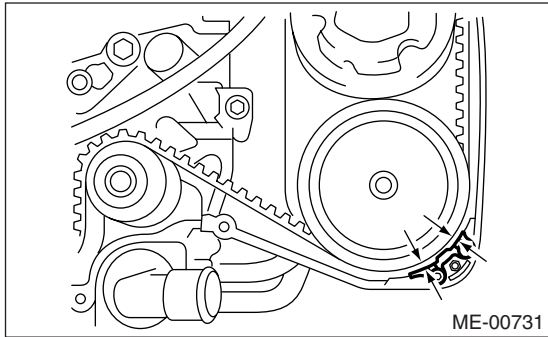
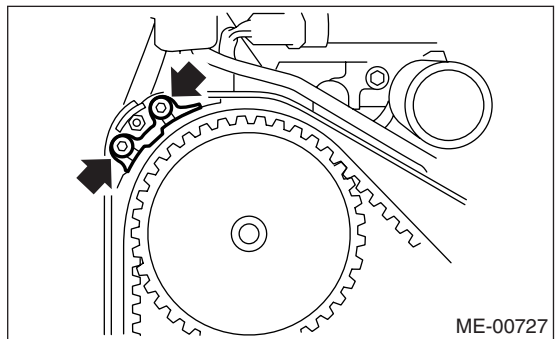

## Tightening torque:

$6.4 \text{ N}\cdot\text{m}$  ( $0.65 \text{ kgf}\cdot\text{m}$ ,  $4.7 \text{ ft}\cdot\text{lb}$ )

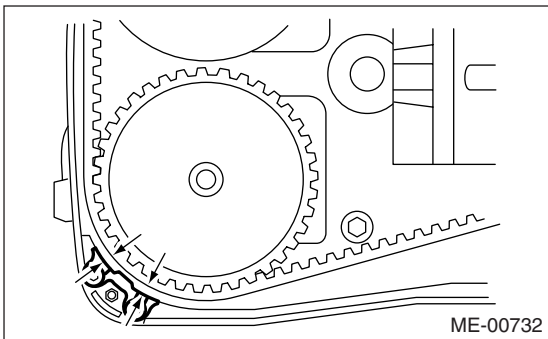
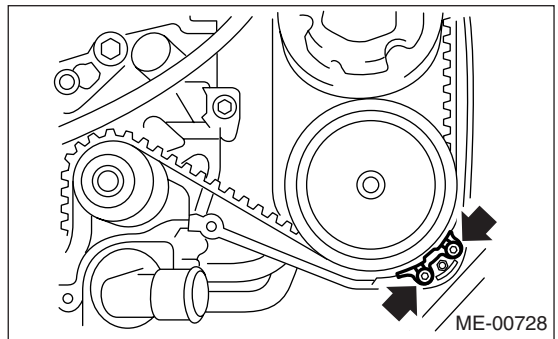

## Tightening torque:

$6.4 \text{ N}\cdot\text{m}$  ( $0.65 \text{ kgf}\cdot\text{m}$ ,  $4.7 \text{ ft}\cdot\text{lb}$ )

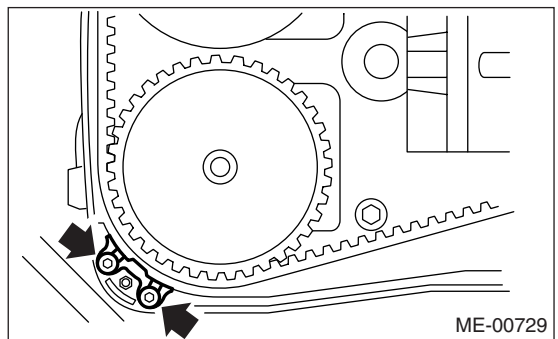

(3) Tighten the bolts.

7) Install the timing belt cover. <Ref. to ME(STI)-43, INSTALLATION, Timing Belt Cover.>

8) Install the crank pulley. <Ref. to ME(STI)-42, INSTALLATION, Crank Pulley.>

9) Install the V-belt. <Ref. to ME(STI)-40, INSTALLATION, V-belt.>

## C: INSPECTION

### 1. TIMING BELT

1) Check the timing belt teeth for breaks, cracks, and wear. If any fault is found, replace the belt.

2) Check the condition of back side of belt; if any crack is found, replace the belt.

#### CAUTION:

- Be careful not to let oil, grease or coolant contact the timing belt. Remove quickly and thoroughly if this happens.
- Do not bend the belt sharply.

**Bending radius h:**

**60 mm (2.36 in) or more**

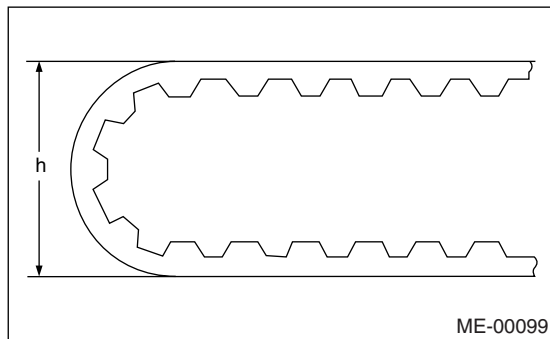

### 2. AUTOMATIC BELT TENSION ADJUST-ER

1) Visually check the oil seals for leaks, and rod ends for abnormal wear or scratches. If necessary, replace the automatic belt tension adjuster assembly.

#### NOTE:

Slight traces of oil at rod's oil seal does not indicate a problem.

2) Check that the adjuster rod does not move when a pressure of 294 N (30 kgf, 66 lbf) is applied to it. This is to check adjuster rod stiffness.

3) If the adjuster rod is not stiff and moves freely when applying 294 N (30 kgf, 66 lbf), check it using the following procedures:

(1) Slowly press the adjuster rod down to the end surface of the cylinder. Repeat this motion 2 or 3 times.

(2) With the adjuster rod moved all the way up, apply a pressure of 294 N (30 kgf, 66 lbf) to it. Check the adjuster rod stiffness.

(3) If the adjuster rod is not stiff and moves down, replace the automatic belt tension adjuster assembly with a new one.

#### CAUTION:

- Always use a vertical type pressing tool to move the adjuster rod down.
- Do not use a lateral type vise.
- Push the adjuster rod vertically.
- Press-in the push adjuster rod gradually taking more than 3 minutes.
- Do not allow press pressure to exceed 9,807 N (1,000 kgf, 2,205 lbf).
- Press the adjuster rod till the end of the surface of the cylinder. Do not press the adjuster rod into the cylinder. Doing so may damage the cylinder.

4) Measure the extension of rod beyond the body. If it is not within specifications, replace with a new one.

**Rod extension H:**

**5.7±0.5 mm (0.224±0.020 in)**

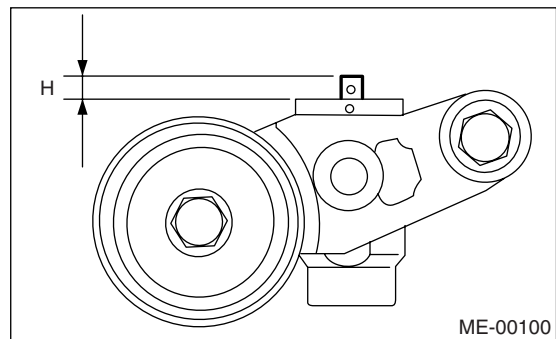

### 3. BELT TENSION PULLEY

1) Check the mating surfaces of timing belt and contact point of adjuster rod for abnormal wear or scratches. Replace the belt tension pulley if faulty.

2) Check the belt tension pulley for smooth rotation. Replace if noise or excessive play is noted.

3) Check the belt tension pulley for grease leakage.

### 4. BELT IDLER

1) Check the belt idler for smooth rotation. Replace if noise or excessive play is noted.

2) Check the outer contacting surfaces of idler pulley for abnormal wear and scratches.

3) Check the belt idler for grease leakage.

# Cam Sprocket

MECHANICAL

## 16. Cam Sprocket

### A: REMOVAL

- 1) Remove the V-belt. <Ref. to ME(STI)-40, REMOVAL, V-belt.>
- 2) Remove the crank pulley. <Ref. to ME(STI)-42, REMOVAL, Crank Pulley.>
- 3) Remove the timing belt cover. <Ref. to ME(STI)-43, REMOVAL, Timing Belt Cover.>
- 4) Remove the timing belt. <Ref. to ME(STI)-44, REMOVAL, Timing Belt.>
- 5) Remove the cam sprockets. To lock the camshaft, use ST.

ST 499207400 CAM SPROCKET WRENCH

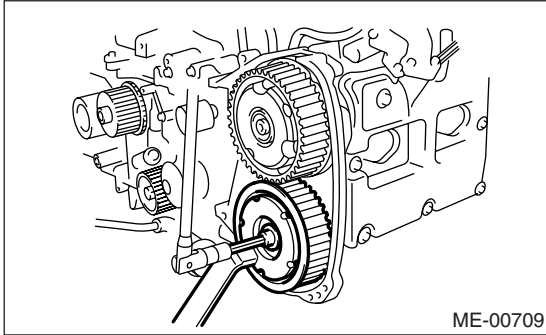

ST 499977500 CAM SPROCKET WRENCH

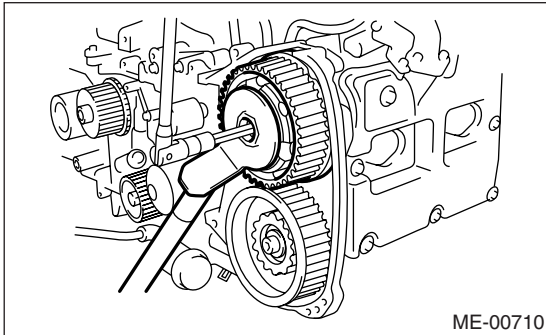

### B: INSTALLATION

- 1) Install the cam sprocket. To lock the camshaft, use ST.

#### NOTE:

Do not confuse cam sprockets (RH) and (LH) during installation.

ST 499207400 CAM SPROCKET WRENCH

### Tightening torque:

**30 N·m (3.0 kgf·m, 21.8 ft·lb), and then tighten 45° furthermore**

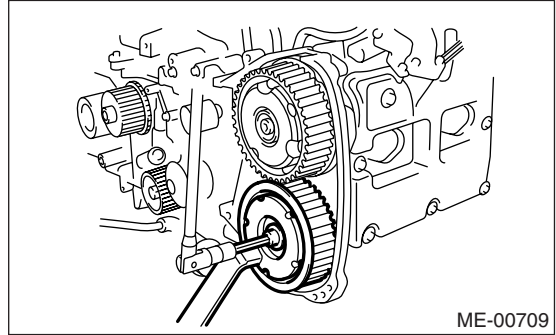

ST 499977500 CAM SPROCKET WRENCH

### Tightening torque:

**30 N·m (3.0 kgf·m, 21.8 ft·lb), and then tighten 45° furthermore**

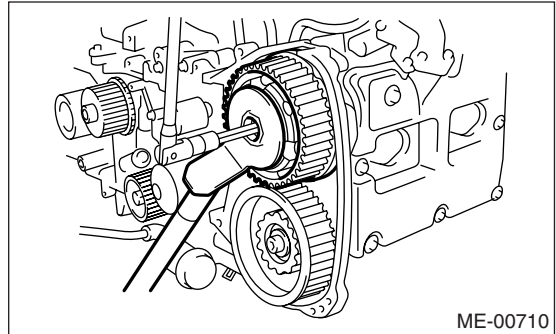

- 2) Install the timing belt. <Ref. to ME(STI)-45, INSTALLATION, Timing Belt.>
- 3) Install the timing belt cover. <Ref. to ME(STI)-43, INSTALLATION, Timing Belt Cover.>
- 4) Install the crank pulley. <Ref. to ME(STI)-42, INSTALLATION, Crank Pulley.>
- 5) Install the V-belt. <Ref. to ME(STI)-40, INSTALLATION, V-belt.>

### C: INSPECTION

- 1) Check the sprocket teeth for abnormal wear and scratches.
- 2) Make sure there is no free play between sprocket and key.
- 3) Check the crank sprocket notch used for sensor for damage and contamination of foreign matter.

## 17.Crank Sprocket

### A: REMOVAL

- 1) Remove the V-belt. <Ref. to ME(STI)-40, REMOVAL, V-belt.>
- 2) Remove the crank pulley. <Ref. to ME(STI)-42, REMOVAL, Crank Pulley.>
- 3) Remove the timing belt cover. <Ref. to ME(STI)-43, REMOVAL, Timing Belt Cover.>
- 4) Remove the timing belt. <Ref. to ME(STI)-44, REMOVAL, Timing Belt.>
- 5) Remove the cam sprocket. <Ref. to ME(STI)-52, REMOVAL, Cam Sprocket.>
- 6) Remove the crank sprocket.

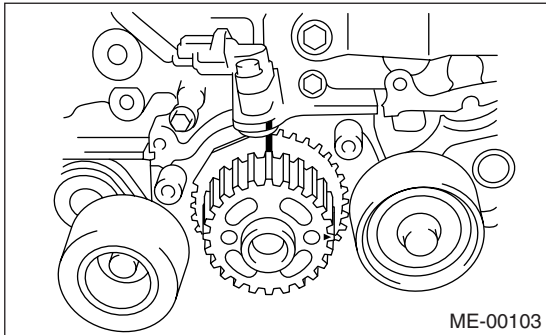

### B: INSTALLATION

- 1) Install the crank sprocket.

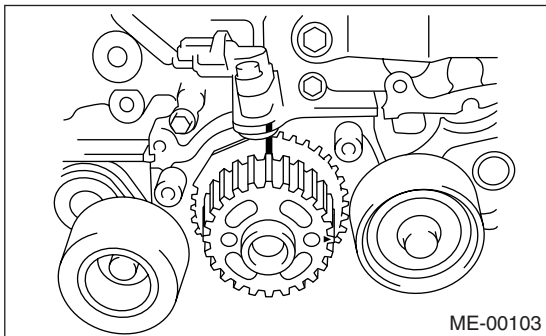

- 2) Install the cam sprocket. <Ref. to ME(STI)-52, INSTALLATION, Cam Sprocket.>
- 3) Install the timing belt. <Ref. to ME(STI)-45, INSTALLATION, Timing Belt.>
- 4) Install the timing belt cover. <Ref. to ME(STI)-43, INSTALLATION, Timing Belt Cover.>
- 5) Install the crank pulley. <Ref. to ME(STI)-42, INSTALLATION, Crank Pulley.>
- 6) Install the V-belt. <Ref. to ME(STI)-40, INSTALLATION, V-belt.>

### C: INSPECTION

- 1) Check the sprocket teeth for abnormal wear and scratches.
- 2) Make sure there is no free play between sprocket and key.
- 3) Check the crank sprocket notch used for sensor for damage and contamination of foreign matter.

## 18. Camshaft

### A: REMOVAL

- 1) Remove the V-belt. <Ref. to ME(STI)-40, REMOVAL, V-belt.>
- 2) Remove the crank pulley. <Ref. to ME(STI)-42, REMOVAL, Crank Pulley.>
- 3) Remove the timing belt cover. <Ref. to ME(STI)-43, REMOVAL, Timing Belt Cover.>
- 4) Remove the timing belt. <Ref. to ME(STI)-44, REMOVAL, Timing Belt.>
- 5) Remove the cam sprocket. <Ref. to ME(STI)-42, REMOVAL, Crank Pulley.>
- 6) Remove the crank sprocket. <Ref. to ME(STI)-53, REMOVAL, Crank Sprocket.>
- 7) Disconnect the oil flow control solenoid valve assembly connector.

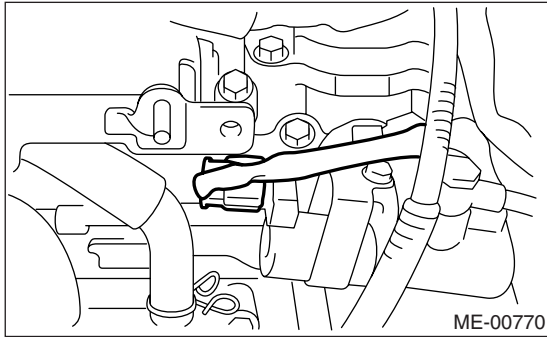

- 8) Remove the tensioner bracket.

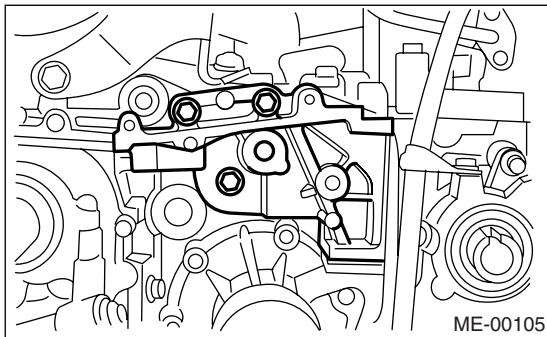

- 9) Remove the timing belt cover No. 2 (LH).

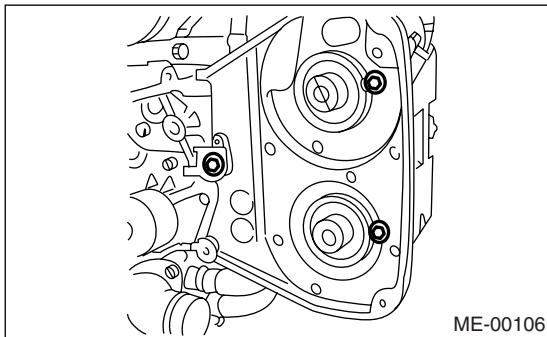

- 10) Remove the timing belt cover No. 2 (RH).

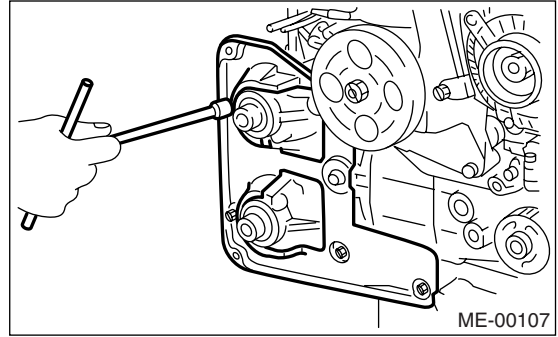

- 11) Remove the spark plug cord.
- 12) Remove the oil level gauge guide. (LH side)
- 13) Remove the rocker cover and gasket.
- 14) Remove the oil pipe.

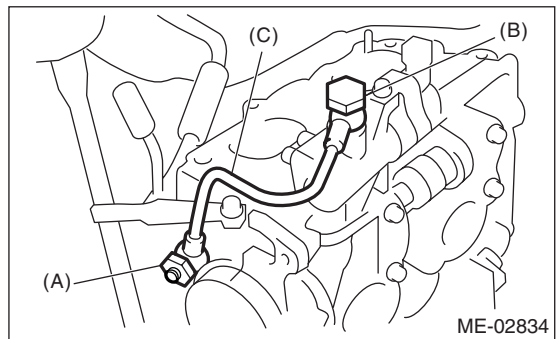

- (A) Union screw (with protrusion)
- (B) Union screw (without protrusion)
- (C) Oil pipe

- 15) Loosen the oil flow control solenoid valve assembly and intake camshaft cap bolts equally, a little at a time in alphabetical sequence shown in the figure.

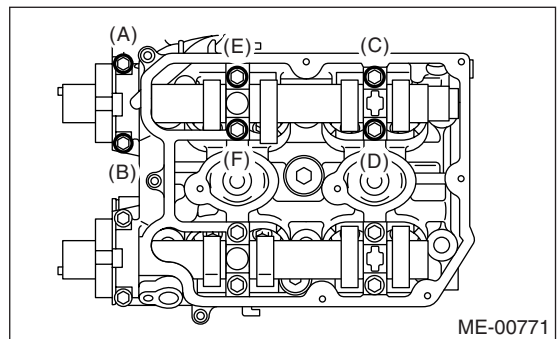



16) Loosen the exhaust camshaft cap bolts equally, a little at a time in alphabetical sequence shown in the figure.

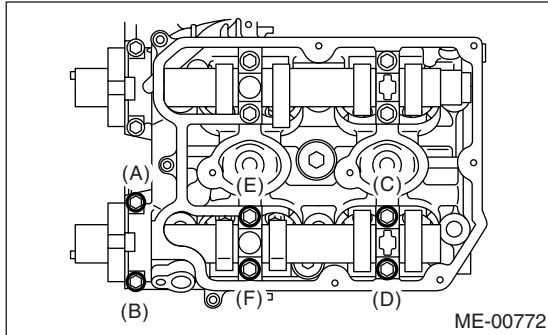

17) Remove the oil flow control solenoid valve assembly, intake camshaft cap, and camshaft.  
18) Remove the exhaust camshaft cap and camshaft.

**NOTE:**

Arrange the camshaft caps in order so that they can be reinstalled in their original positions.

19) Similarly, remove the camshafts (RH) and related parts.

## B: INSTALLATION

### 1) Camshaft installation

Apply engine oil to cylinder head at camshaft bearing location before installing the camshaft. Install the camshaft so that each valve is close to or in contact with “base circle” of cam lobe.

**NOTE:**

- When the camshafts are positioned as shown in the figure, camshafts need to be rotated at a minimum to align with the timing belt during installation.

- Camshaft (RH) need not be rotated when set at position shown in the figure. Intake camshaft (LH): Rotate 80° clockwise. Exhaust camshaft (LH): Rotate 45° counterclockwise.

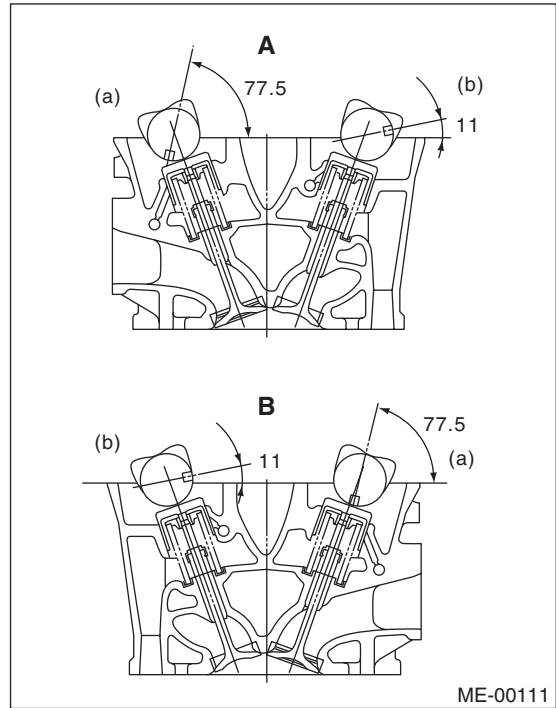

- A Cylinder head (LH)
- B Cylinder head (RH)
- (a) Intake camshaft
- (b) Exhaust camshaft

### 2) Camshaft cap and oil flow control solenoid valve assembly installation

(1) Apply liquid gasket sparingly to cap mating surface.

**NOTE:**

Do not apply liquid gasket excessively. Failure to do so may cause excess gasket to come out and flow toward the oil seal, resulting in oil leaks.

**Liquid gasket:**

**Part No. 004403007**

**THREE BOND 1215 or equivalent**

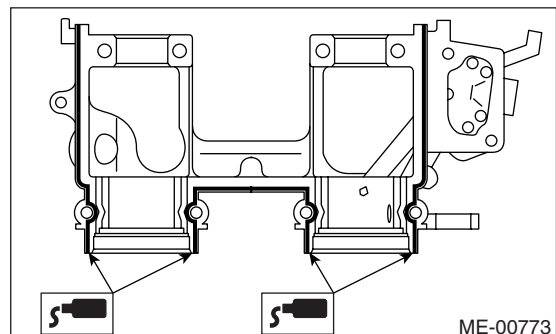

# Camshaft

## MECHANICAL

(2) Apply engine oil to cap bearing surface and install the cap on camshaft.

(3) Gradually tighten the camshaft cap and oil control valve assembly in at least two stages in alphabetical sequence shown in the figure, and then tighten to specified torque.

### Tightening torque:

**T1: 9.75 N·m (1.0 kgf·m, 7 ft·lb)**

**T2: 20 N·m (2.0 kgf·m, 14.8 ft·lb)**

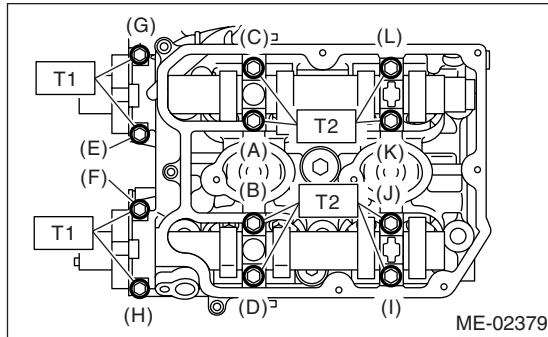

(4) After tightening camshaft cap, ensure the camshaft rotates only slightly while holding it at “base” circle.

3) Apply engine oil to the outer perimeter and lips of oil seal, and install the oil seal on camshaft using ST1 and ST2.

### NOTE:

Use a new oil seal.

ST1 499587600 OIL SEAL GUIDE

ST2 499597200 OIL SEAL GUIDE

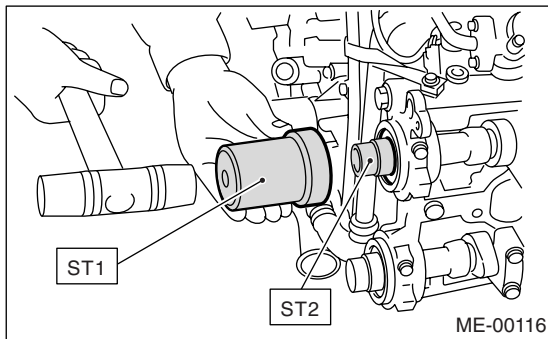

### 4) Rocker cover installation

(1) Install the gasket on rocker cover. Install the nearby gaskets and ignition coil gasket.

### NOTE:

Use a new gasket.

(2) Apply liquid gasket to the specified point of cylinder head.

### NOTE:

Apply liquid gasket to the half moon plug portion with sticking out more than 5 mm (0.2 in).

### Liquid gasket:

**THREE BOND 1215 (Part No. 004403007) or equivalent**

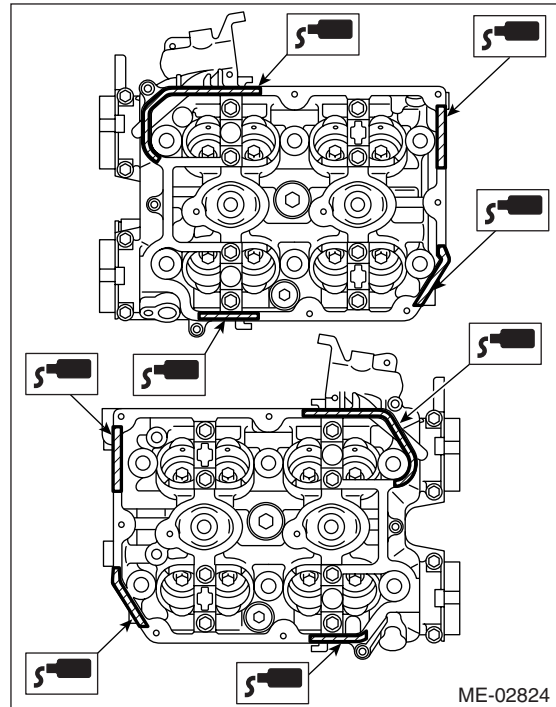

(3) Install the rocker cover on cylinder head. Ensure the gasket is properly positioned during installation.

(4) Tighten the rocker cover tightening bolt in alphabetical sequence shown in the figure, and then tighten to specified torque.

### Tightening torque:

**6.4 N·m (0.65 kgf·m, 4.7 ft·lb)**

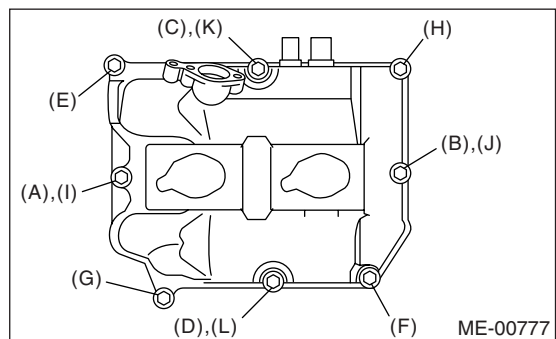



5) Install the oil pipe. Assemble the union screw to the location as shown in the figure during installation.

**Tightening torque:**  
**29 N·m (3.0 kgf·m, 21.4 ft·lb)**

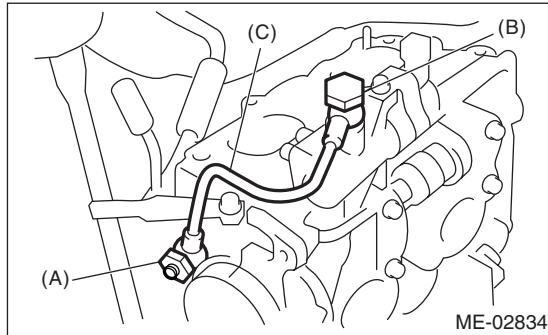

- (A) Union screw (with protrusion)
- (B) Union screw (without protrusion)
- (C) Oil pipe

6) Connect the oil flow control solenoid valve connector.

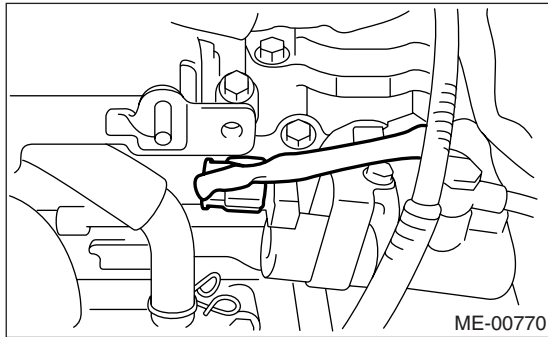

- 7) Install the spark plug cord.
- 8) Similarly, install the parts on right-hand side.
- 9) Install the timing belt cover No. 2 (RH).

**Tightening torque:**  
**5 N·m (0.5 kgf·m, 3.6 ft·lb)**

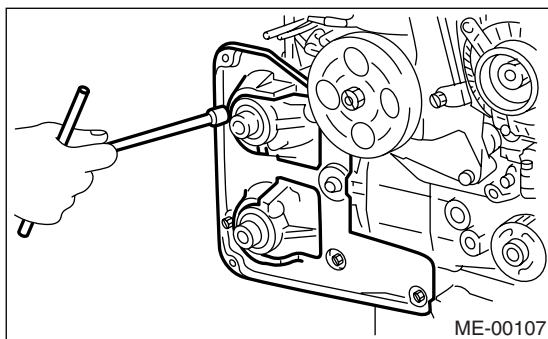

10) Install the timing belt cover No. 2 (LH).

**Tightening torque:**  
**5 N·m (0.5 kgf·m, 3.6 ft·lb)**

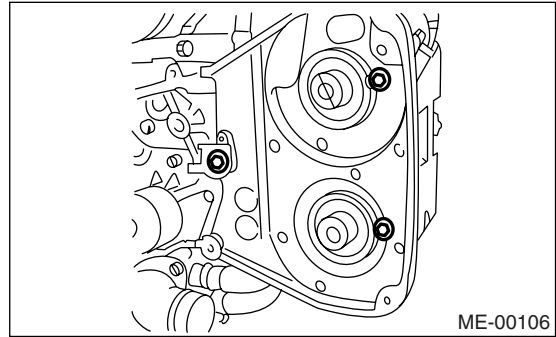

11) Install the tensioner bracket.

**Tightening torque:**  
**24.5 N·m (2.5 kgf·m, 18.1 ft·lb)**

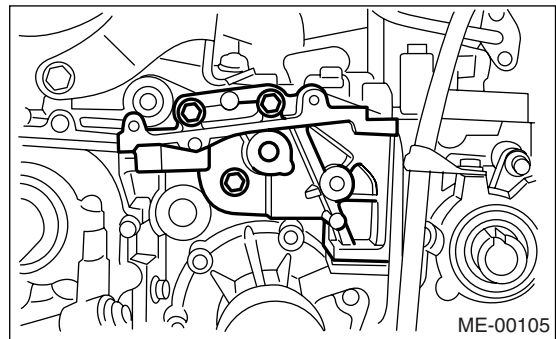

12) Install the crank sprocket. <Ref. to ME(STI)-53, INSTALLATION, Crank Sprocket.>

13) Install the cam sprockets. <Ref. to ME(STI)-52, INSTALLATION, Cam Sprocket.>

14) Install the timing belt. <Ref. to ME(STI)-45, INSTALLATION, Timing Belt.>

15) Install the timing belt cover. <Ref. to ME(STI)-43, INSTALLATION, Timing Belt Cover.>

16) Install the crank pulley. <Ref. to ME(STI)-42, INSTALLATION, Crank Pulley.>

17) Install the V-belt. <Ref. to ME(STI)-40, INSTALLATION, V-belt.>

# Camshaft

MECHANICAL

## C: INSPECTION

1) Measure the bend, and repair or replace if necessary.

**Limit:**

**0.020 mm (0.00079 in)**

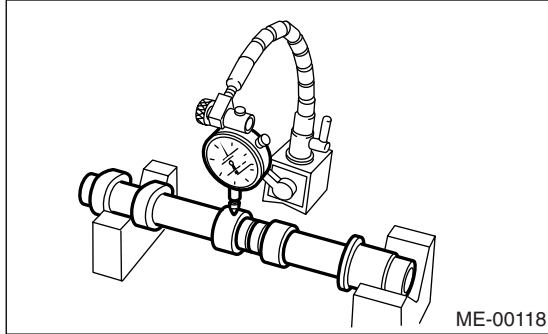

2) Check the journal for damage and wear. Replace if faulty.

3) Measure the outside diameter of camshaft journal. If the journal diameter is not as specified, check the oil clearance.

	Camshaft journal	
	Front	Center, rear
Standard	37.946 — 37.963 mm (1.4939 — 1.4946 in)	29.946 — 29.963 mm (1.1790 — 1.1796 in)

4) Measurement of the camshaft journal oil clearance

- (1) Clean the bearing caps and camshaft journals.
- (2) Place the camshafts on cylinder head.
- (3) Place a plastigauge across each of the camshaft journals.
- (4) Gradually tighten the cap in at least two stages in alphabetical sequence shown in the figure, and then tighten to specified torque. Do not turn the camshaft.

**Tightening torque:**

**T1: 10 N·m (1.0 kgf·m, 7.4 ft·lb)**

**T2: 20 N·m (2.0 kgf·m, 14.8 ft·lb)**

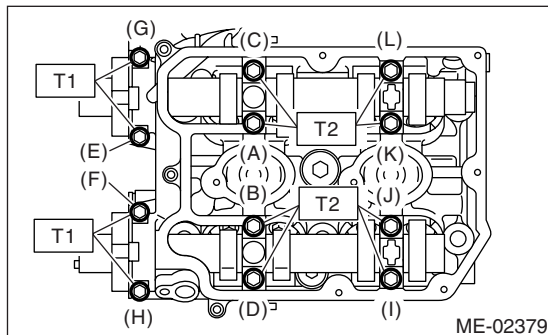

(5) Remove the bearing caps.

(6) Measure the widest point of plastigauge on each journal. If the oil clearance exceeds the limit, replace the camshaft. If necessary, replace the camshaft caps and cylinder head as a set.

**Standard:**

**0.037 — 0.072 mm (0.0015 — 0.0028 in)**

**Limit:**

**0.10 mm (0.0039 in)**

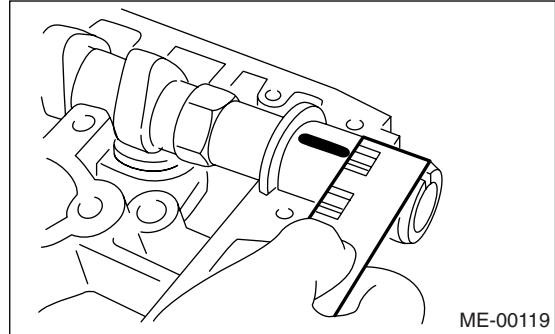

(7) Completely remove the plastigauge.

5) Check the cam face condition, and remove the minor faults by grinding with oil stone. Measure the cam height H. If it exceeds the limit or offset wear occurs, replace the camshaft.

**Cam height H:**

**Standard:**

**Intake:**

**46.55 — 46.65 mm (1.833 — 1.837 in)**

**Exhaust:**

**46.75 — 46.85 mm (1.841 — 1.844 in)**

**Limit:**

**Intake:**

**46.45 mm (1.829 in)**

**Exhaust:**

**46.65 mm (1.837 in)**

**Cam base circle diameter A:**

**37.0 mm (1.457 in)**

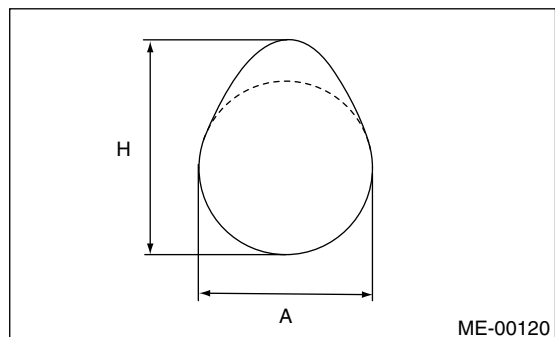

6) Measure the thrust clearance of camshaft with dial gauge. If the thrust clearance exceeds the limit, replace the caps and cylinder head as a set. If necessary, replace the camshaft.

**Standard:**

**0.068 — 0.116 mm (0.0027 — 0.0046 in)**

**Limit:**

**0.14 mm (0.0055 in)**

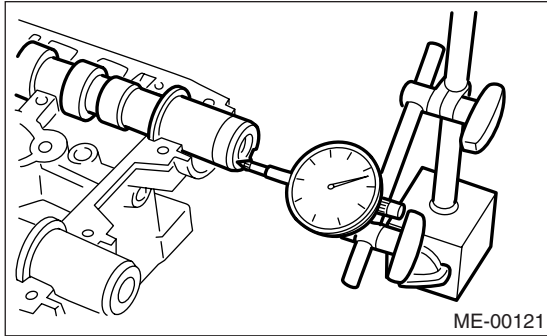

## 19. Cylinder Head

### A: REMOVAL

- 1) Remove the V-belt. <Ref. to ME(STI)-40, REMOVAL, V-belt.>
  - 2) Remove the crank pulley. <Ref. to ME(STI)-42, REMOVAL, Crank Pulley.>
  - 3) Remove the timing belt cover. <Ref. to ME(STI)-43, REMOVAL, Timing Belt Cover.>
  - 4) Remove the timing belt. <Ref. to ME(STI)-44, REMOVAL, Timing Belt.>
  - 5) Remove the cam sprocket. <Ref. to ME(STI)-52, REMOVAL, Cam Sprocket.>
  - 6) Remove the intake manifold. <Ref. to FU(STI)-13, REMOVAL, Intake Manifold.>
  - 7) Remove the bolt which installs the A/C compressor bracket on cylinder head.
  - 8) Remove the camshaft. <Ref. to ME(STI)-54, REMOVAL, Camshaft.>
  - 9) Remove the cylinder head bolts in alphabetical sequence shown in the figure.
- Leave bolts (A) and (D) engaged by three or four threads to prevent the cylinder head from falling.

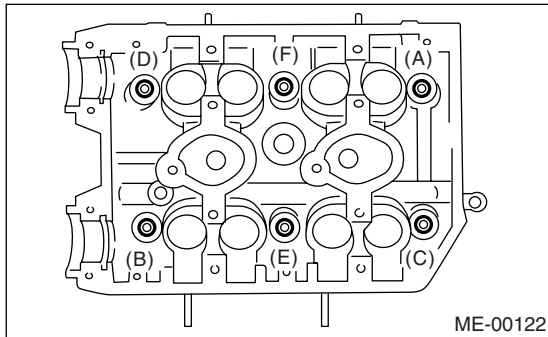

- 10) While tapping the cylinder head with a plastic hammer, separate it from cylinder block. Remove the bolts (A) and (D) to remove cylinder head.

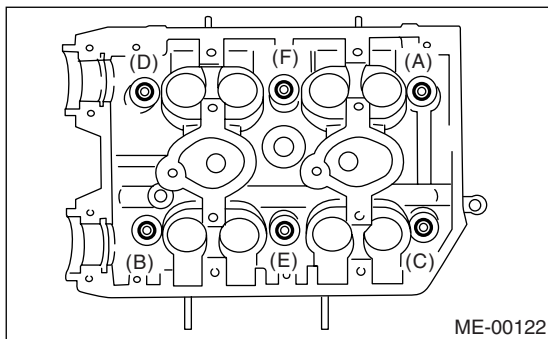

- 11) Remove the cylinder head gasket.

### CAUTION:

**Be careful not to scratch the mating surface of cylinder head and cylinder block.**

- 12) Similarly, remove the cylinder head (RH).

### B: INSTALLATION

- 1) Install the cylinder head and gaskets on cylinder block.

### CAUTION:

- Use new cylinder head gaskets.
  - Be careful not to scratch the mating surface of cylinder head and cylinder block.
- 2) Tighten the cylinder head bolts.
    - (1) Apply a coat of engine oil to the washers and bolt threads.
    - (2) Tighten all bolts to 29 N·m (3.0 kgf-m, 21.4 ft-lb) in alphabetical sequence.
    - (3) Tighten all bolts to 69 N·m (7.0 kgf-m, 50.9 ft-lb) in alphabetical sequence again.
    - (4) Back off all bolts by 180° first; back them off by 180° again in reverse order of installation.
    - (5) Tighten all bolts to 49 N·m (5.0 kgf-m, 36 ft-lb) in alphabetical sequence.
    - (6) Tighten all bolts 80 to 90° in alphabetical sequence.
    - (7) Tighten all bolts by 40 to 45° in alphabetical sequence again.

### CAUTION:

**Do not tighten the bolts by more than 45°.**

- (8) Further tighten all bolts (A) and (B) by 40 to 45°.

### CAUTION:

**Ensure that the total “re-tightening angle” in the previous two steps do not exceed 90°.**

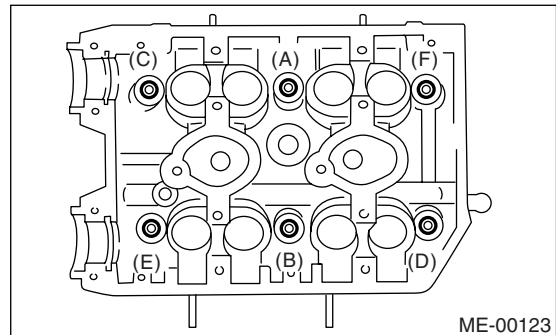

- 3) Install the camshaft. <Ref. to ME(STI)-55, INSTALLATION, Camshaft.>
- 4) Install the A/C compressor bracket on cylinder head.
- 5) Install the intake manifold. <Ref. to FU(STI)-16, INSTALLATION, Intake Manifold.> <Ref. to FU(STI)-44, RELEASING OF FUEL PRESSURE, PROCEDURE, Fuel.>
- 6) Install the cam sprocket. <Ref. to ME(STI)-52, INSTALLATION, Cam Sprocket.>
- 7) Install the timing belt. <Ref. to ME(STI)-45, INSTALLATION, Timing Belt.>
- 8) Install the timing belt cover. <Ref. to ME(STI)-43, INSTALLATION, Timing Belt Cover.>

9) Install the crank pulley. <Ref. to ME(STI)-42, INSTALLATION, Crank Pulley.>

10) Install the V-belt. <Ref. to ME(STI)-40, INSTALLATION, V-belt.>

## C: DISASSEMBLY

1) Remove the valve lifters.

2) Compress the valve spring and remove the valve spring retainer key. Remove each valve and valve spring.

ST1 498267600 CYLINDER HEAD TABLE

ST2 499718000 VALVE SPRING REMOVER

### NOTE:

Keep the removed parts in order for re-installing in their original positions.

### CAUTION:

- Mark each valve to prevent confusion.
- Use extreme care not to damage the lips of the intake valve oil seals and exhaust valve oil seals.

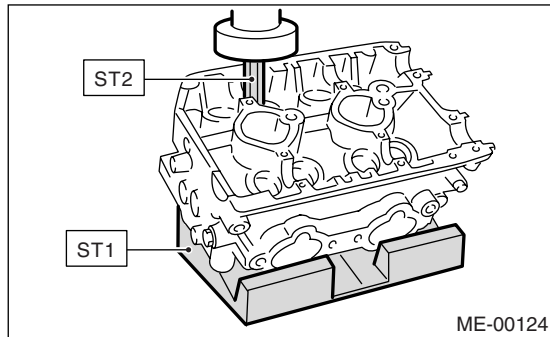

# Cylinder Head

MECHANICAL

## D: ASSEMBLY

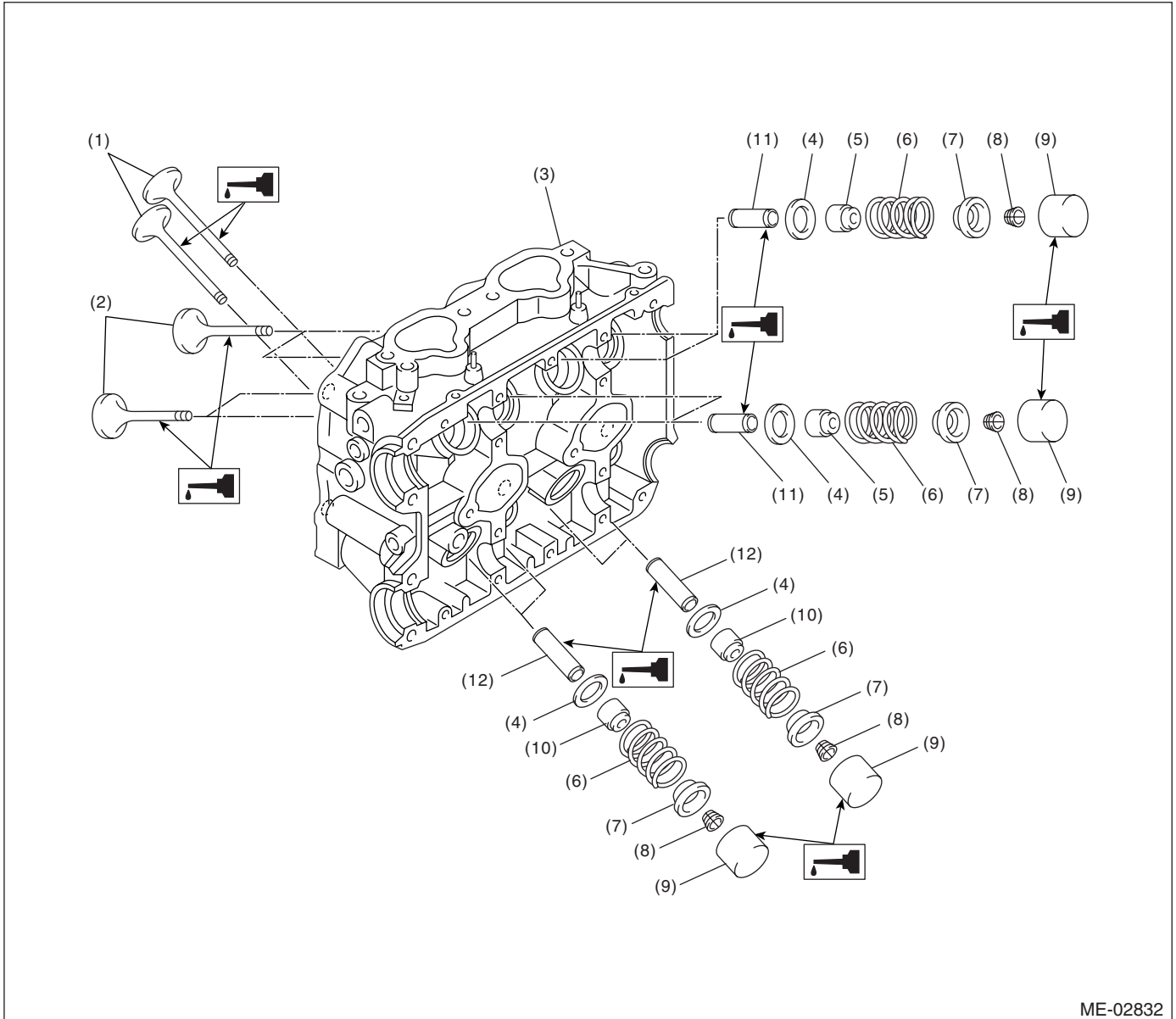

ME-02832

- |                       |                           |                             |
|-----------------------|---------------------------|-----------------------------|
| (1) Exhaust valve     | (5) Intake valve oil seal | (9) Valve lifter            |
| (2) Intake valve      | (6) Valve spring          | (10) Exhaust valve oil seal |
| (3) Cylinder head     | (7) Retainer              | (11) Intake valve guide     |
| (4) Valve spring seat | (8) Retainer key          | (12) Exhaust valve guide    |

### 1) Installation of valve spring and valve:

- (1) Coat the stem of each valve with engine oil and insert the valve into valve guide.

#### NOTE:

When inserting the valve into valve guide, use special care not to damage the oil seal lip.

- (2) Set the cylinder head on ST1.
- (3) Install the valve spring and retainer using ST2.

ST1 498267600 CYLINDER HEAD TABLE  
ST2 499718000 VALVE SPRING REMOVER

**NOTE:**

Be sure to install the valve springs with their close-coiled end facing the seat on cylinder head.

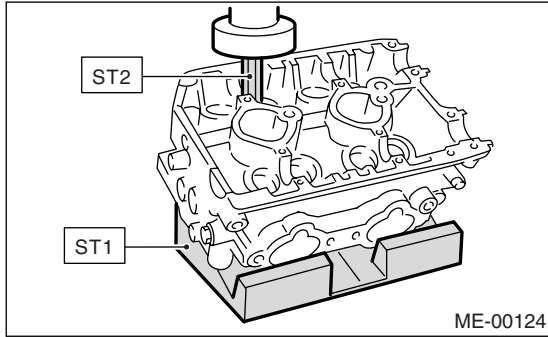

ME-00124

(4) Compress the valve spring, and then fit the valve spring retainer key.

(5) After installing, tap the valve spring retainers lightly with wooden hammer for better seating.

2) Apply oil to the surface of the valve lifter.

3) Install the valve lifter.

**E: INSPECTION**

**1. CYLINDER HEAD**

1) Make sure that no crack or other damage exists. In addition to visual inspection, inspect the important areas by means of liquid penetrant tester.

2) Measure the warping of the cylinder head surface that mates with crankcase by using a straight edge (A) and thickness gauge (B).

If the warping exceeds the limit, grind the surface with a surface grinder.

**Warping limit:**  
0.035 mm (0.0014 in)

**Grinding limit:**  
0.3 mm (0.012 in)

**Standard height of cylinder head:**  
127.5 mm (5.02 in)

**NOTE:**

Uneven torque for the cylinder head nuts can cause warping. When reassembling, pay special attention to the torque so as to tighten evenly.

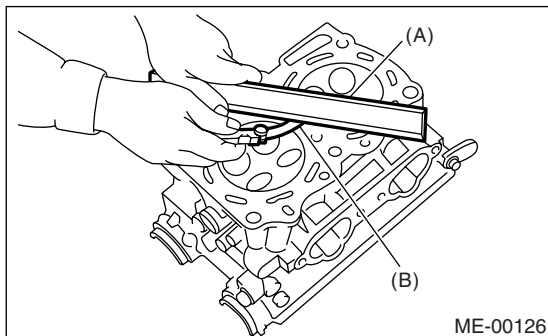

ME-00126

**2. VALVE SEAT**

Inspect the intake and exhaust valve seats, and then correct the contact surfaces with valve seat cutter if they are defective or when valve guides are replaced.

**Valve seat contact width W:**

**Intake**

**Standard** 0.6 — 1.6 mm (0.024 — 0.055 in)

**Limit** 1.7 mm (0.067 in)

**Exhaust**

**Standard** 1.2 — 1.8 mm (0.047 — 0.071 in)

**Limit** 2.2 mm (0.087 in)

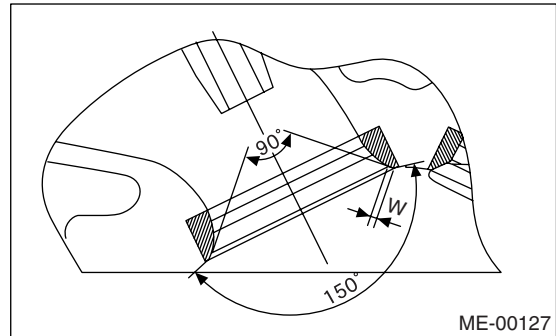

ME-00127

**3. VALVE GUIDE**

1) Check the clearance between valve guide and stem. The clearance can be checked by measuring the outside diameter of valve stem and the inside diameter of valve guide with outside and inside micrometers respectively.

**Clearance between the valve guide and valve stem:**

**Standard**

**Intake**

0.030 — 0.057 mm (0.0012 — 0.0022 in)

**Exhaust**

0.040 — 0.067 mm (0.0016 — 0.0026 in)

**Limit**

0.15 mm (0.0059 in)

2) If the clearance between valve guide and stem exceeds the limit, replace the valve guide or valve itself whichever shows greater amount of wear. See the following procedure for valve guide replacement.

**Valve guide inner diameter:**

6.000 — 6.012 mm (0.2362 — 0.2367 in)

**Valve stem outer diameters:**

**Intake**

5.955 — 5.970 mm (0.2344 — 0.2350 in)

**Exhaust**

5.945 — 5.960 mm (0.2341 — 0.2346 in)



# Cylinder Head

## MECHANICAL

- (1) Place the cylinder head on ST1 with the combustion chamber upward so that valve guides enter the holes in ST1.
- (2) Insert the ST2 into valve guide and press it down to remove the valve guide.

ST1 498267600 CYLINDER HEAD TABLE  
ST2 499767200 VALVE GUIDE REMOVER

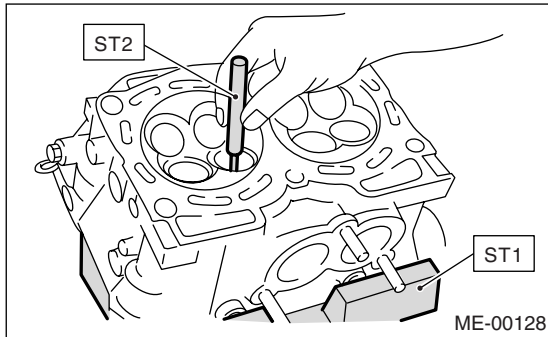

- (3) Turn the cylinder head upside down and place ST as shown in the figure.

ST 18251AA020 VALVE GUIDE ADJUSTER

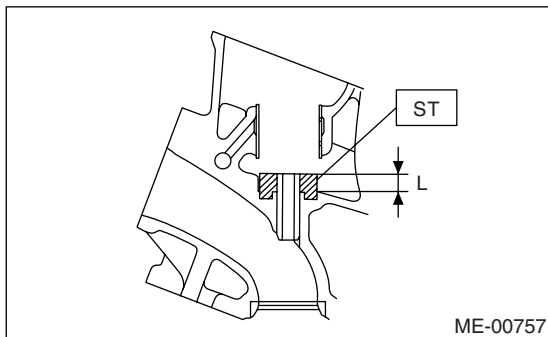

- (4) Before installing a new valve guide, make sure that neither scratches nor damages exist on the inside surface of the valve guide holes in cylinder head.
- (5) Put a new valve guide, coated with sufficient oil, in cylinder, and insert ST1 into valve guide. Press in until the valve guide upper end is flush with the upper surface of ST2.

ST1 499767200 VALVE GUIDE REMOVER  
ST2 18251AA020 VALVE GUIDE ADJUSTER

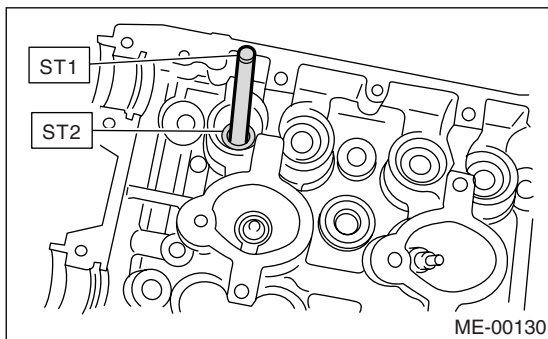

- (6) Check the valve guide protrusion.

### Valve guide protrusion L:

15.8 — 16.2 mm (0.622 — 0.638 in)

- (7) Ream the inside of valve guide with ST. Gently rotate the reamer clockwise while pressing it lightly into the valve guide, and return it also rotating clockwise. After reaming, clean the valve guide to remove chips.

ST 499767400 VALVE GUIDE REAMER

### NOTE:

- Apply engine oil to the reamer when reaming.
- If the inner surface of the valve guide is torn, the edge of the reamer should be slightly ground with an oil stone.
- If the inner surface of the valve guide becomes lustrous and the reamer does not chip, use a new reamer or remedy the reamer.

- (8) Recheck the contact condition between valve and valve seat after replacing the valve guide.



## 4. INTAKE AND EXHAUST VALVE

1) Inspect the flange and stem of valve, and replace if damaged, worn, or deformed, or if head edge thickness "H" is less than the specified limit.

### Head edge thickness H:

#### Intake (A)

**Standard 1.0 — 1.4 mm (0.039 — 0.055 in)**

**Limit 0.8 mm (0.031 in)**

#### Exhaust (B)

**Standard 1.3 — 1.7 mm (0.051 — 0.067 in)**

**Limit 0.8 mm (0.031 in)**

### Valve overall length:

#### Intake (A)

**104.4 mm (4.110 in)**

#### Exhaust (B)

**104.65 mm (4.120 in)**

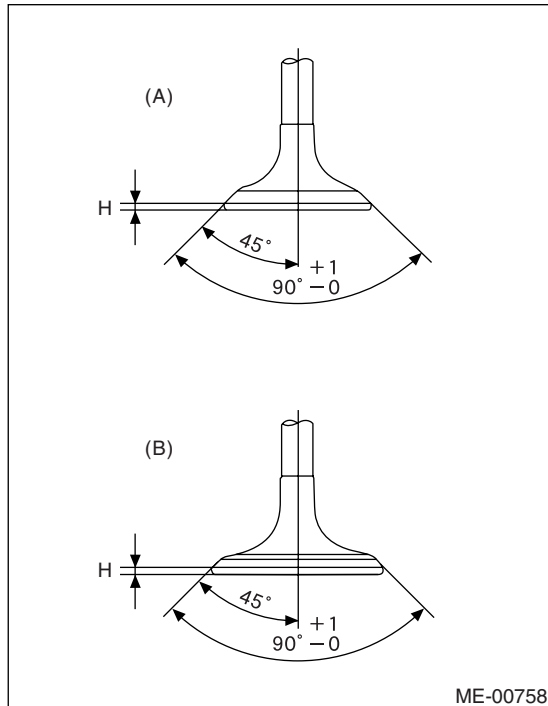

2) Put a small amount of grinding compound on the seat surface and lap the valve and seat surface. Install a new intake valve oil seal after lapping.

## 5. VALVE SPRINGS

1) Check the valve springs for damage, free length, and tension. Replace the valve spring if it is not within specifications presented in the table.

2) To measure the squareness of valve spring, stand the spring on a surface plate and measure its deflection at the top using a try square.

		Valve spring
Free length		47.32 mm (1.863 in)
Tension/spring height	Set	205 — 235 N (20.9 — 24.0 kgf, 46.1 — 52.8 lbf) /36.0 mm (1.417 in)
	Lift	426 — 490 N (43.4 — 50.0 kgf, 95.8 — 110 lbf) /26.50 mm (1.043 in)
Squareness		2.5°, 2.1 mm (0.083 in) or less

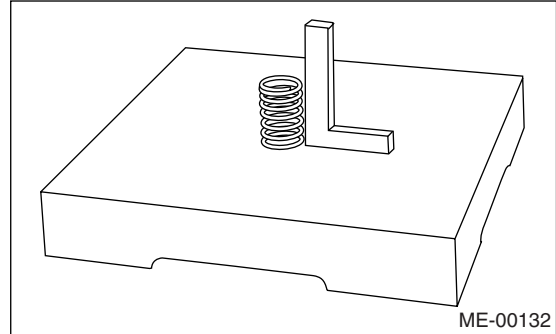

## 6. INTAKE AND EXHAUST VALVE OIL SEAL

In the following case, pinch and remove the oil seal from valve using pliers, and then replace it with a new one.

- When the lip is damaged.
- When the spring is out of the specified position.
- When readjusting the surfaces of valve and valve seat.
- When replacing the intake valve guide.

- 1) Place the cylinder head on ST1.
- 2) Press in the oil seal to the specified dimension indicated in the figure by using ST2.

ST1 498267600 CYLINDER HEAD TABLE

ST2 498857100 VALVE OIL SEAL GUIDE

### NOTE:

- Apply engine oil to oil seal before press-fit.
- Differentiate between the intake valve oil seal and exhaust valve oil seal by noting their difference in color.

### Color of rubber part:

**Intake [Gray] Exhaust [Green]**

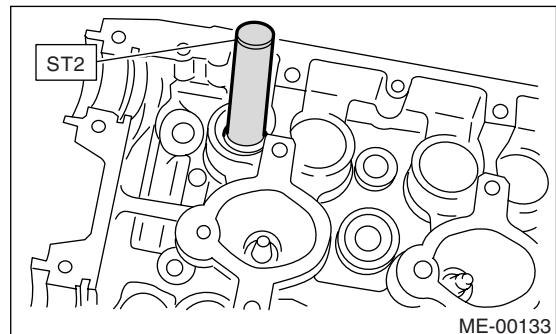

# Cylinder Head

MECHANICAL

## 7. VALVE LIFTER

- 1) Visually check the valve lifter.
- 2) Measure the outer diameter of valve lifter.

### Outer diameter:

**34.959 — 34.975 mm (1.3763 — 1.3770 in)**

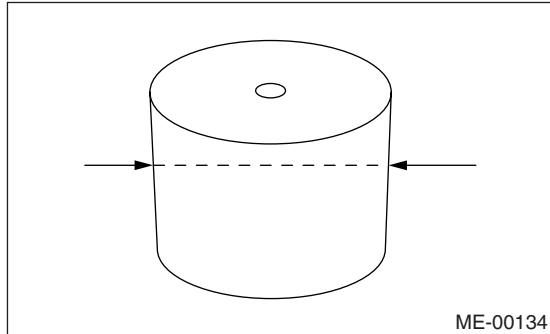

- 3) Measure the inner diameter of valve lifter mating part on cylinder head.

### Inner diameter:

**34.994 — 35.016 mm (1.3777 — 1.3786 in)**

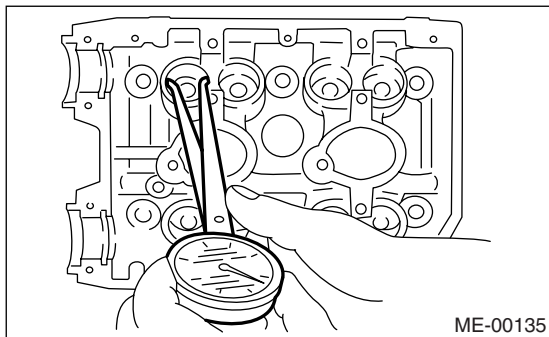

### NOTE:

If difference between outer diameter of valve lifter and inner diameter of valve lifter mating part is over the limit, replace the cylinder head.

### Standard:

**0.019 — 0.057 mm (0.0007 — 0.0022 in)**

### Limit:

**0.100 mm (0.0039 in)**

## F: DISPOSAL

### CAUTION:

- Metallic sodium is enclosed in the exhaust valve. Metallic sodium is extremely alkaline and may produce severe chemical reactions. Full consideration must therefore be given to the following points when handling or disposing of the valve.
- Since metallic sodium may cause blindness if contacted with the eyes, burns if contacted with the skin, and fire, do not deliberately take the valve apart.

If the valve is damaged, remove the valve and neutralize it by immersing it in water, and dispose of it in the same way that general steel materials are disposed of. The disposal method is described in the following.

- 1) Wearing rubber gloves, remove the damaged valve from the cylinder head.
- 2) Prepare a large receptacle (bucket or other container) in a well ventilated location, and fill the receptacle with water (at least 10 ℓ (21.14 US qt, 17.6 Imp qt)).
- 3) Immerse the damaged valve in the receptacle.

### CAUTION:

**A severe reaction may occur, so stand at least 2 — 3 m from the receptacle. Because the reaction will produce hydrogen gas, moreover, keep the receptacle away from sparks or flames.**

- 4) Once the reaction is completed (about 4 — 5 hours have elapsed), carefully remove the valve using large pincers so that the reaction liquid does not contact your skin, and dispose of it with other parts that are being disposed of.

- 5) The reaction liquid is a strong alkaline solution, so it must be disposed of in accordance with local regulations.

### CAUTION:

**Make sure the reaction liquid does not contact your skin. If contact with skin occurs, immediately wash the affected area with large quantities of water.**

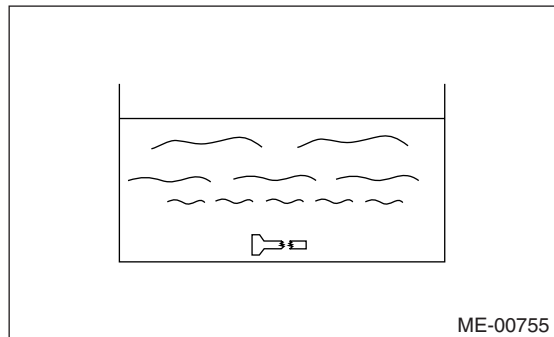

## 20. Cylinder Block

### A: REMOVAL

**NOTE:**

Before conducting this procedure, drain the engine oil completely if applicable.

- 1) Remove the intake manifold. <Ref. to FU(STI)-13, REMOVAL, Intake Manifold.>
- 2) Remove the V-belt. <Ref. to ME(STI)-40, REMOVAL, V-belt.>
- 3) Remove the crank pulley. <Ref. to ME(STI)-42, REMOVAL, Crank Pulley.>
- 4) Remove the timing belt cover. <Ref. to ME(STI)-43, REMOVAL, Timing Belt Cover.>
- 5) Remove the timing belt. <Ref. to ME(STI)-44, REMOVAL, Timing Belt.>
- 6) Remove the cam sprocket. <Ref. to ME(STI)-52, REMOVAL, Cam Sprocket.>
- 7) Remove the crank sprocket. <Ref. to ME(STI)-53, REMOVAL, Crank Sprocket.>
- 8) Remove the generator and A/C compressor with their brackets.
- 9) Remove the cylinder head. <Ref. to ME(STI)-60, REMOVAL, Cylinder Head.>
- 10) Remove the clutch disc and cover. <Ref. to CL-14, REMOVAL, Clutch Disc and Cover.>
- 11) Remove the flywheel. <Ref. to CL-17, REMOVAL, Flywheel.>

ST 498497100 CRANKSHAFT STOPPER

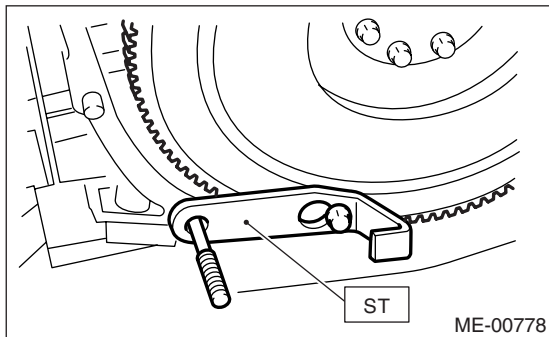

- 12) Remove the oil separator cover.
  - 13) Remove the water by-pass pipe for heater.
  - 14) Remove the oil filter using ST.
- ST 18332AA010 OIL FILTER WRENCH (Outer diameter: 65 mm (2.56 in))
- ST 18332AA000 OIL FILTER WRENCH (Outer diameter: 68 mm (2.68 in))

**NOTE:**

Standard oil filter is outer diameter of 65 mm (2.56 in). However, SUBARU genuine oil filter having outer diameter of 68 mm (2.68 in) can also be used.

- 15) Remove the oil cooler.

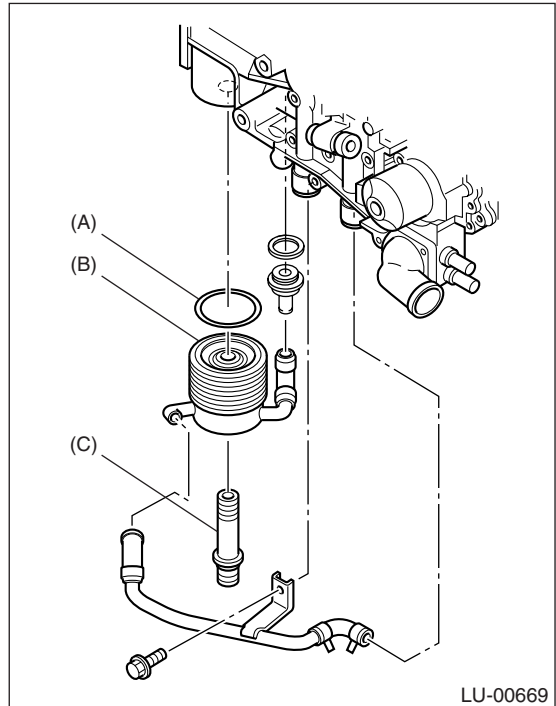

- (A) Gasket
- (B) Oil cooler
- (C) Oil cooler connector

- 16) Remove the water pump.
- 17) Remove the oil pump from cylinder block. Use a flat-bladed screwdriver as shown in the figure when removing the oil pump.

**NOTE:**

Be careful not to scratch the mating surface of cylinder block and oil pump.

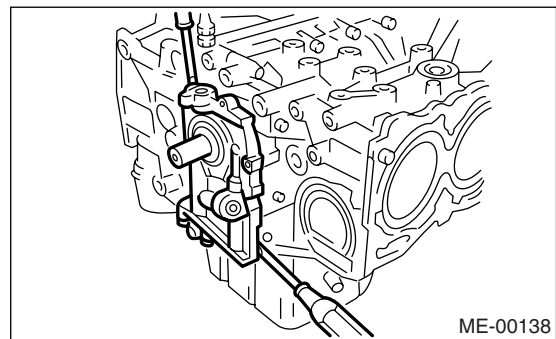

- 18) Removal of oil pan:
  - (1) Turn the cylinder block with #2 and #4 piston sides facing upward.
  - (2) Remove the bolts which secure oil pan to cylinder block.
  - (3) Insert an oil pan cutter blade between cylinder block-to-oil pan clearance, and then remove the oil pan. Do not use a screwdriver or similar tool in place of oil pan cutter.

# Cylinder Block

## MECHANICAL

- 19) Remove the oil strainer stay.
- 20) Remove the oil strainer.

- 21) Remove the baffle plate.
- 22) Remove the water pipes.

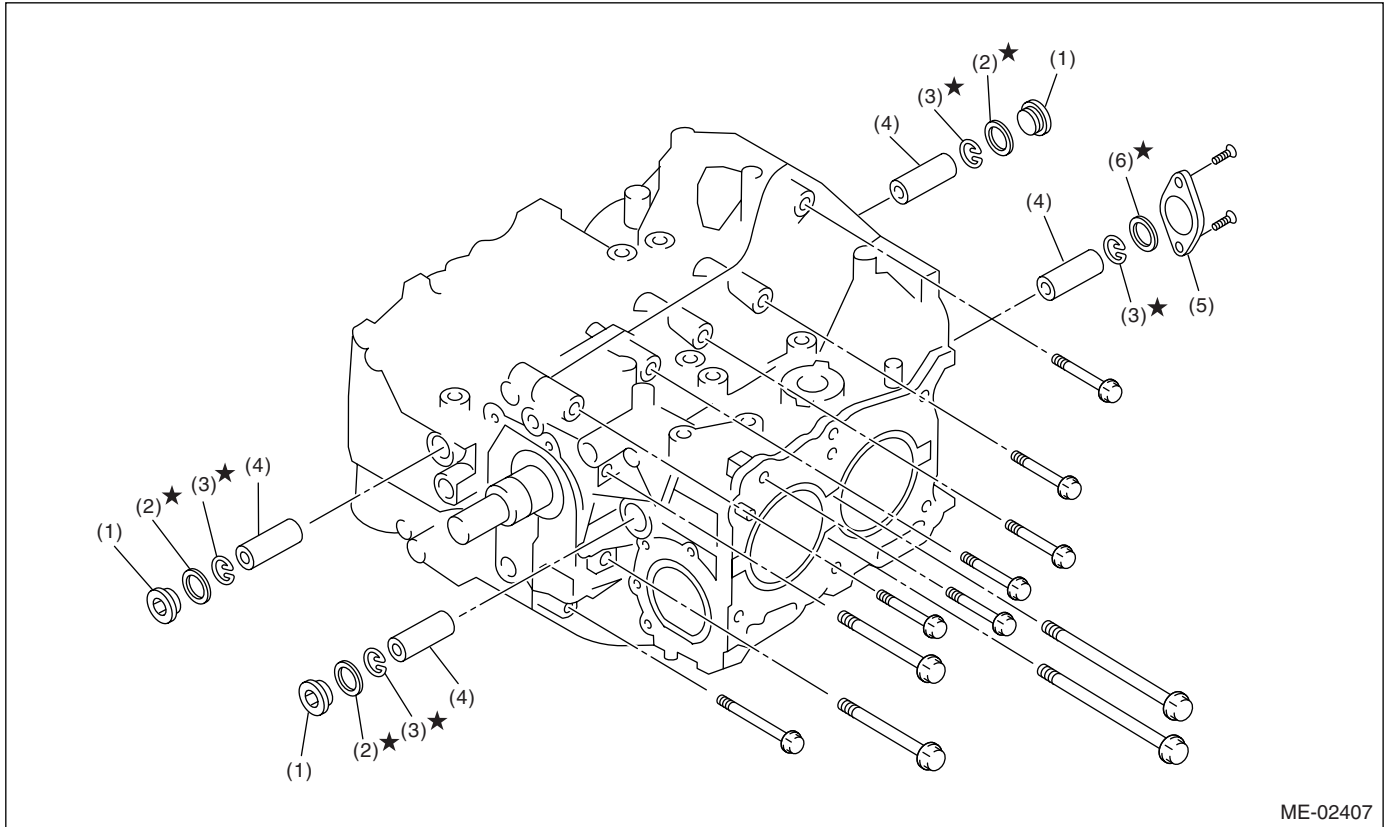

ME-02407

- |                       |                |                        |
|-----------------------|----------------|------------------------|
| (1) Service hole plug | (3) Snap ring  | (5) Service hole cover |
| (2) Gasket            | (4) Piston pin | (6) O-ring             |

- 23) Remove the service hole cover and service hole plugs using hexagon wrench (14 mm).

- 24) Rotate the crankshaft to bring #1 and #2 pistons to bottom dead center position, and then remove the piston snap ring through service hole of #1 and #2 cylinders.

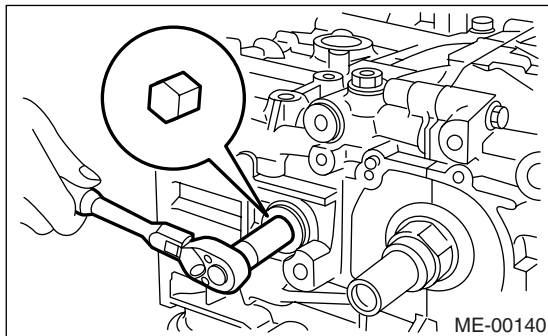

ME-00140

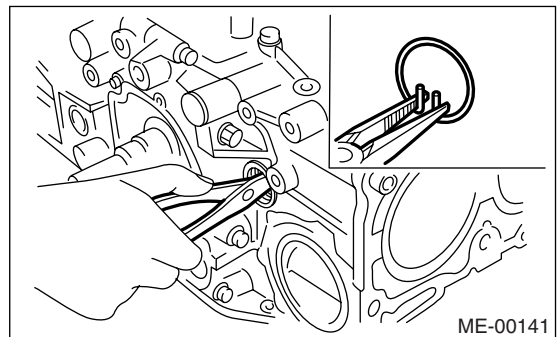

ME-00141

- 25) Draw out the piston pin from #1 and #2 pistons using ST.

ST 499097700 PISTON PIN REMOVER ASSY

# Cylinder Block

MECHANICAL

**NOTE:**

Be careful not to confuse the original combination of piston, piston pin and cylinder.

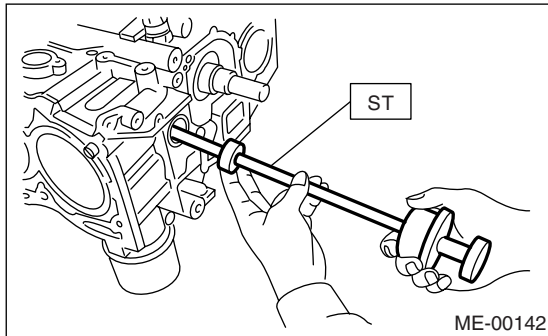

26) Similarly remove the piston pins from #3 and #4 pistons.

27) Remove the bolts which connect the cylinder block on the side of #2 and #4 cylinders.

28) Back off the bolts which connect the cylinder block on the side of #1 and #3 cylinders two or three turns.

29) Set up the cylinder block so that #1 and #3 cylinders are on the upper side, then remove the cylinder block connecting bolts.

30) Separate the cylinder blocks (LH) and (RH).

**NOTE:**

When separating the cylinder block, do not allow the connecting rod to fall or damage the cylinder block.

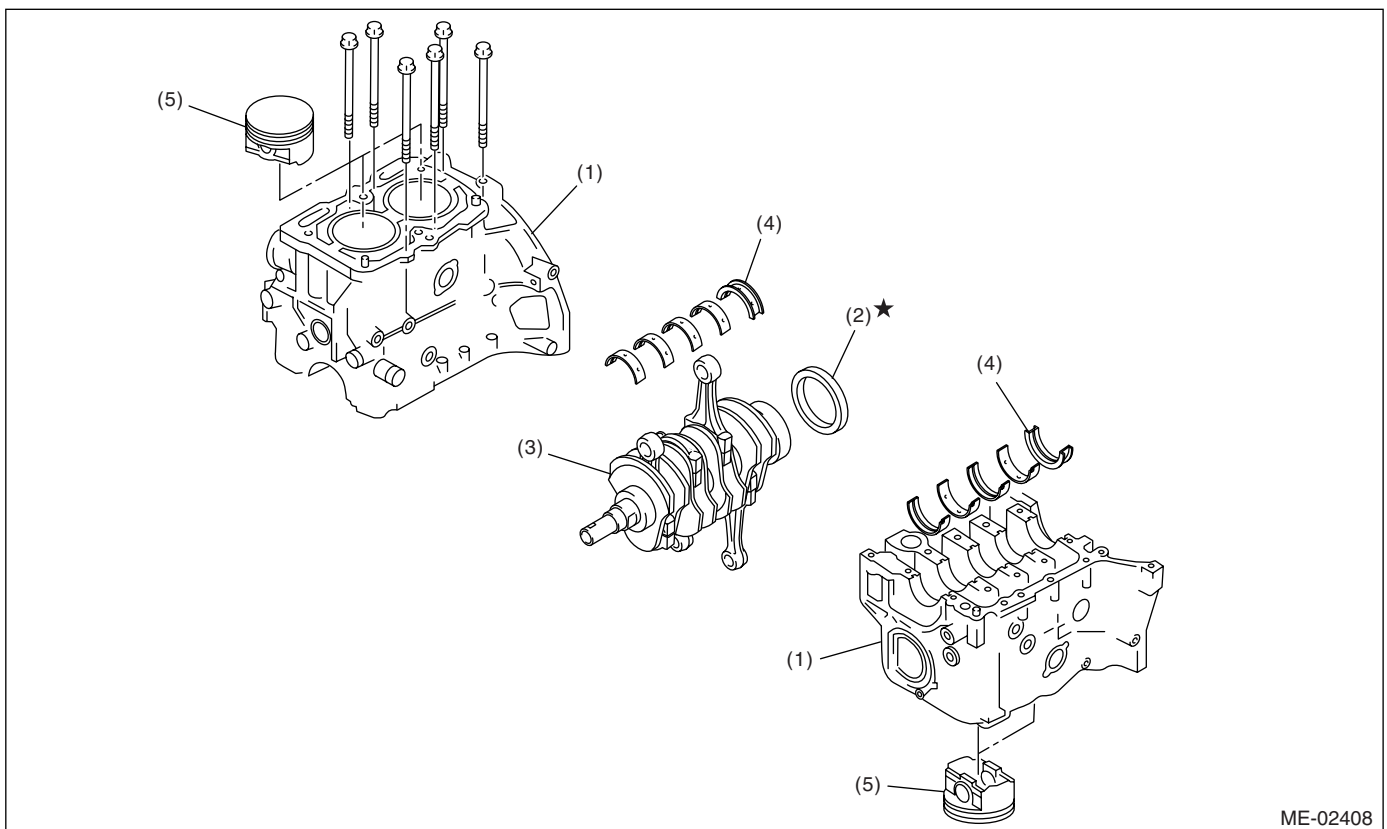

(1) Cylinder block

(2) Rear oil seal

(3) Crankshaft

(4) Crankshaft bearing

(5) Piston

31) Remove the rear oil seal.

32) Remove the crankshaft together with connecting rod.

33) Remove the crankshaft bearings from cylinder block using a hammer handle.

**NOTE:**

Do not confuse the combination of crankshaft bearings. Press the bearing at the end opposite to locking lip.

34) Draw out each piston from cylinder block using a wooden bar or hammer handle.

**NOTE:**

Be careful not to confuse the original combination of piston and cylinder.

# Cylinder Block

MECHANICAL

## B: INSTALLATION

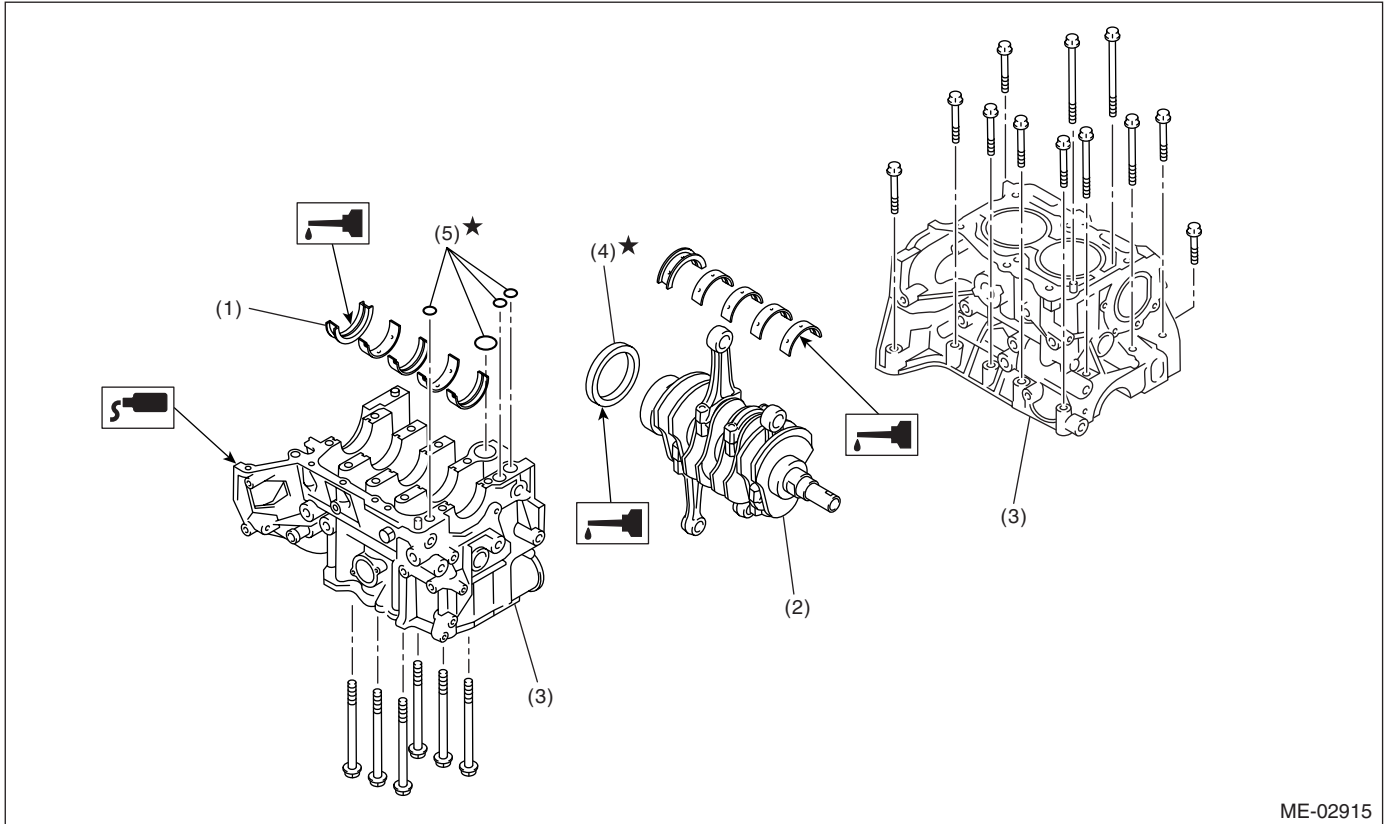

ME-02915

- |                        |                    |            |
|------------------------|--------------------|------------|
| (1) Crankshaft bearing | (3) Cylinder block | (5) O-ring |
| (2) Crankshaft         | (4) Rear oil seal  |            |

1) Remove oil in the mating surface of bearing and cylinder block before installation. Also apply engine oil to crankshaft pins.

2) Position the crankshaft and O-ring on #1 and #3 cylinder block.

3) Apply liquid gasket to the mating surface of #1 and #3 cylinder block, and position #2 and #4 cylinder block.

### Liquid gasket:

**THREE BOND 1215 (Part No. 004403007) or equivalent**

### NOTE:

Do not allow liquid gasket to jut into O-ring grooves, oil passages, bearing grooves, etc.

4) Apply engine oil to washers and thread of bolts.

5) Tighten the 10 mm cylinder block connecting bolts in alphabetical sequence shown in the figure. (LH side)

### Tightening torque:

**10 N·m (1.0 kgf·m, 7.4 ft·lb)**

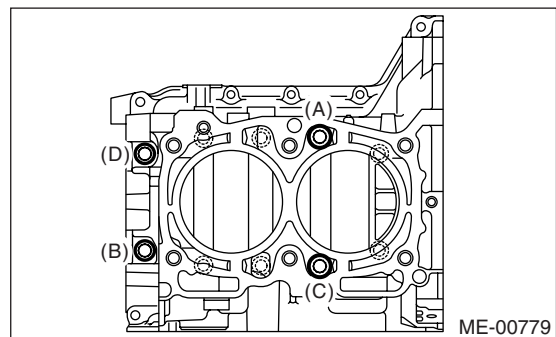

ME-00779

6) Tighten the 10 mm cylinder block connecting bolts in alphabetical sequence shown in the figure. (RH side)

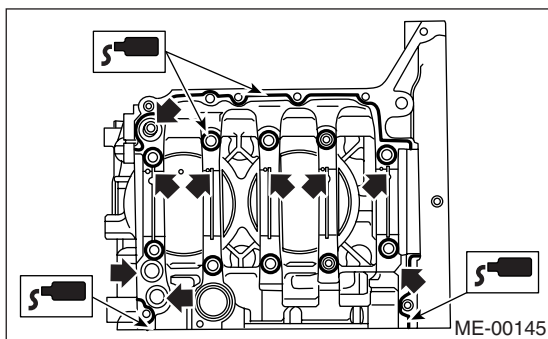

ME-00145



**Tightening torque:**

**10 N·m (1.0 kgf·m, 7.4 ft-lb)**

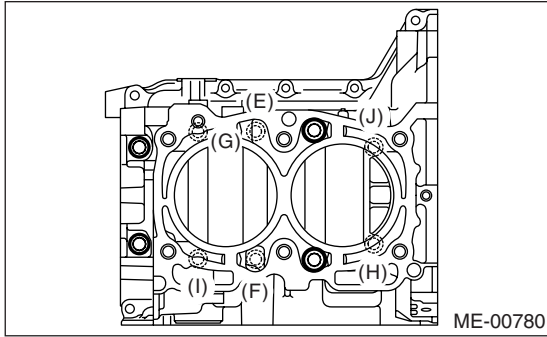

7) Further tighten the LH side bolts (A) — (D) in alphabetical sequence.

**Tightening torque:**

**18 N·m (1.8 kgf·m, 13.3 ft-lb)**

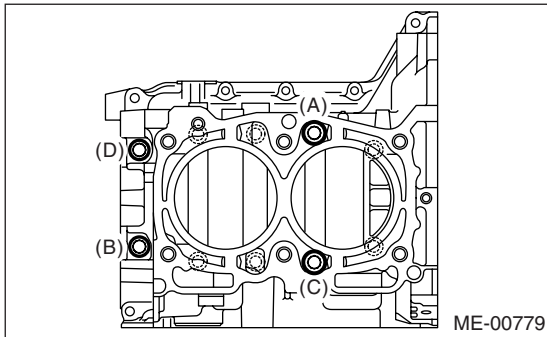

8) Further tighten the RH side bolts (E) — (J) in alphabetical sequence.

**Tightening torque:**

**18 N·m (1.8 kgf·m, 13.3 ft-lb)**

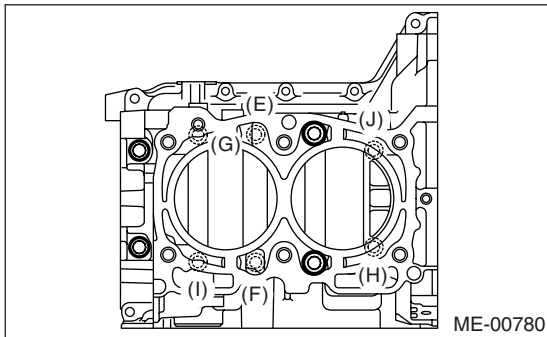

9) Further tighten the LH side bolts (A) — (D) in alphabetical sequence, by 90° for (A) and (C), and to 40 N·m (4.1 kgf·m, 29.5 ft-lb) for (B) and (D).

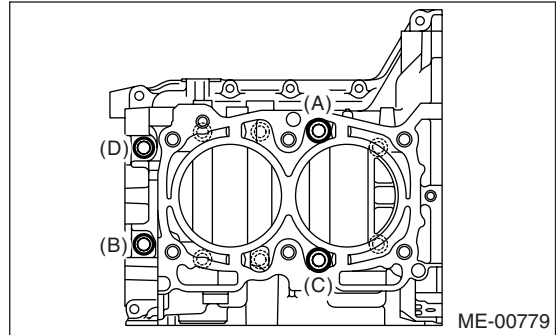

10) Further tighten the RH side bolts (E) — (J) by 90° in alphabetical sequence.

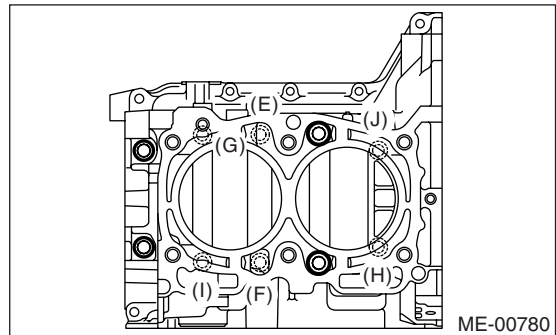

11) Tighten the 8 mm and 6 mm cylinder block connecting bolts in alphabetical sequence shown in the figure.

**Tightening torque:**

**(A) — (G): 25 N·m (2.5 kgf·m, 18.4 ft-lb)**

**(H): 6.4 N·m (0.65 kgf·m, 4.7 ft-lb)**

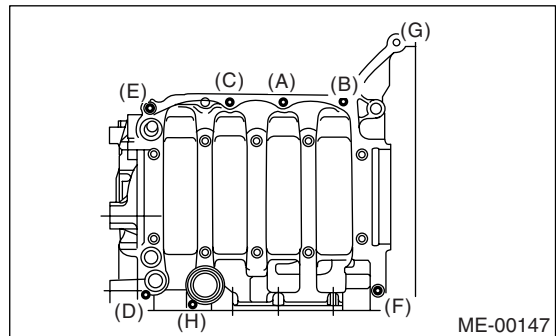

12) Apply engine oil to the outer perimeter of rear oil seal, and install the rear oil seal using ST1 and ST2.

**NOTE:**

Use a new rear oil seal.

ST1 499597100 CRANKSHAFT OIL SEAL GUIDE

# Cylinder Block

MECHANICAL

## ST2 499587200 CRANKSHAFT OIL SEAL INSTALLER

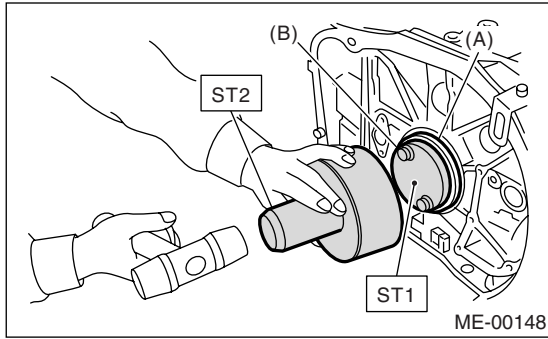

- (A) Rear oil seal
- (B) Flywheel attaching bolt

13) Position the top ring gap at (A) or (B) in the figure.

14) Position the second ring gap at 180° on the reverse side for the top ring gap.

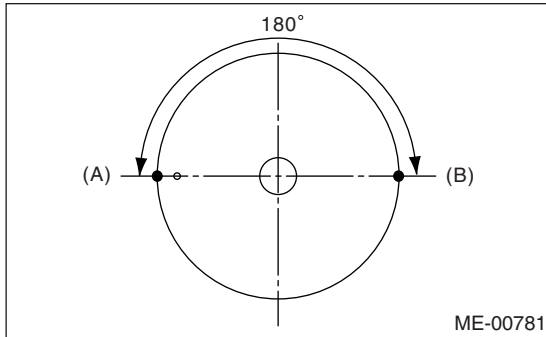

15) Position the upper rail gap at (C) in the figure.

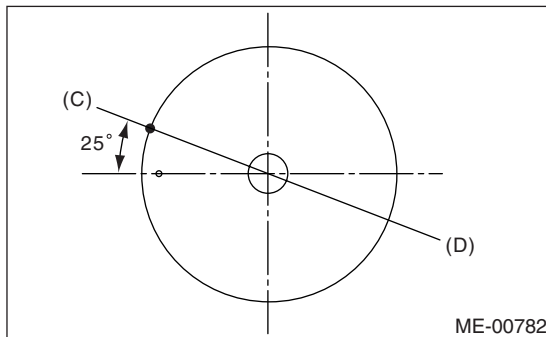

16) Align upper rail spin stopper (D) with piston side surface hole (E).

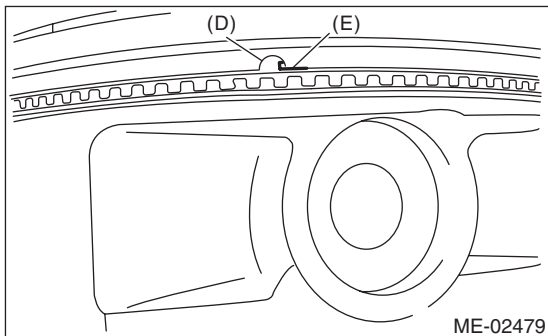

17) Position the expander gap at (F) in the figure.

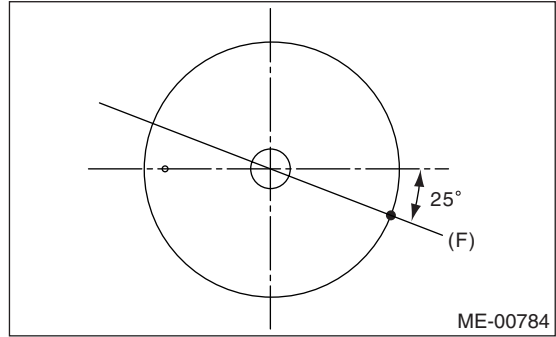

18) Position the lower rail gap at (G) in the figure.

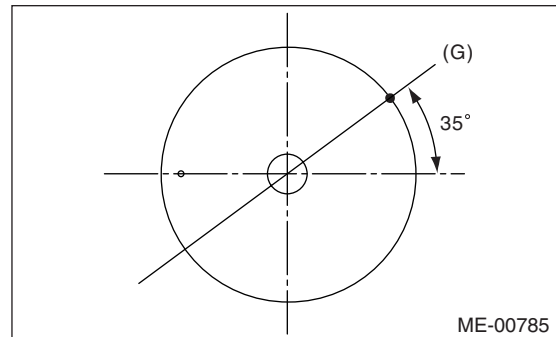

### CAUTION:

- Ensure ring gaps do not face the same direction.
- Ensure ring gaps are not within the piston skirt area.

19) Install the snap ring.

Install the snap rings in piston holes located opposite of service holes in cylinder block, when positioning all pistons in the corresponding cylinders.

### NOTE:

Use new snap rings.

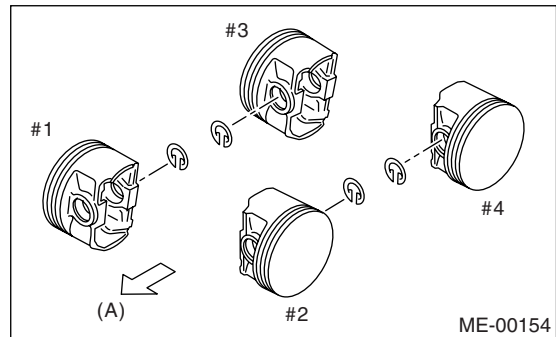

(A) Front side



# Cylinder Block

MECHANICAL

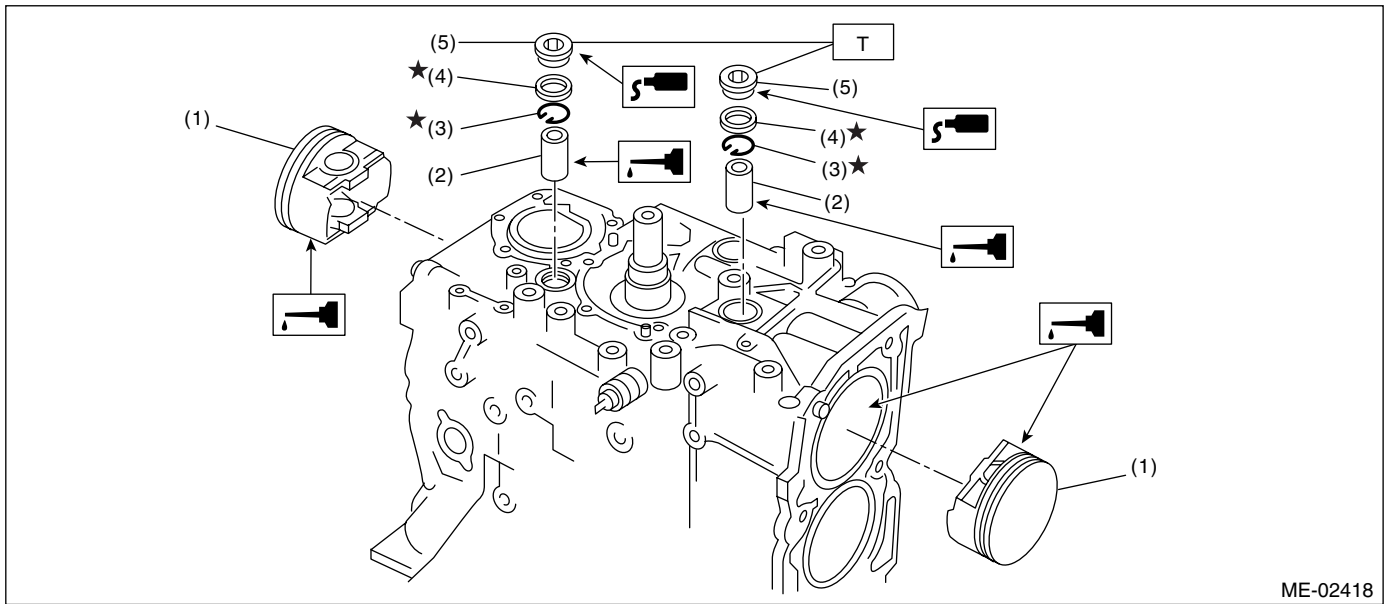

ME-02418

- |                |                       |
|----------------|-----------------------|
| (1) Piston     | (4) Gasket            |
| (2) Piston pin | (5) Service hole plug |
| (3) Snap ring  |                       |

**Tightening torque: N-m (kgf-m, ft-lb)**  
**T: 70 (7.1, 51.6)**

## 20) Piston installation:

- (1) Turn the cylinder block so that #1 and #2 cylinders face upward.
- (2) Using the ST1, turn the crankshaft so that #1 and #2 connecting rods are set at bottom dead center.

### ST1 499987500 CRANKSHAFT SOCKET

- (3) Apply a coat of engine oil to the pistons and cylinders and insert pistons in their cylinders using ST2.

### ST2 498747300 PISTON GUIDE

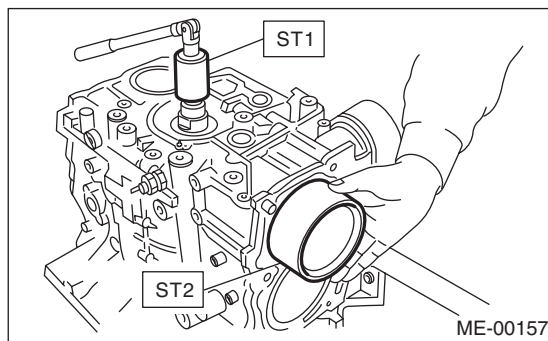

## NOTE:

Piston front mark faces towards the front of the engine.

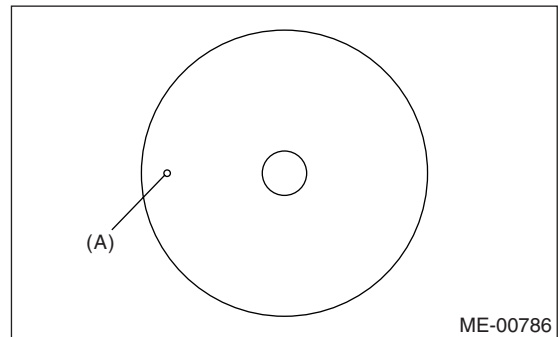

(A) Front mark

## 21) Piston pin installation:

- (1) Apply a coat of engine oil to ST3, and then insert the ST3 into service hole to align piston pin hole with connecting rod small end.

### ST3 499017100 PISTON PIN GUIDE

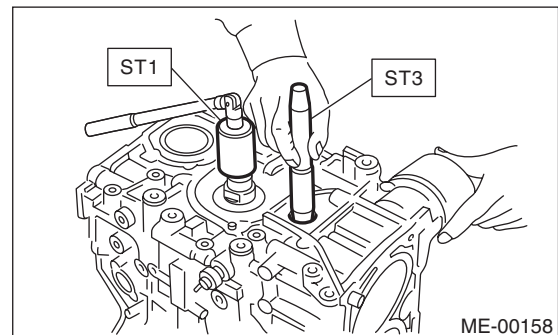

# Cylinder Block

## MECHANICAL

---

- (2) Apply a coat of engine oil to the piston pin and insert piston pin into piston and connecting rod through service hole.
- (3) Using the ST, install the snap ring.

**NOTE:**

Use new snap rings.

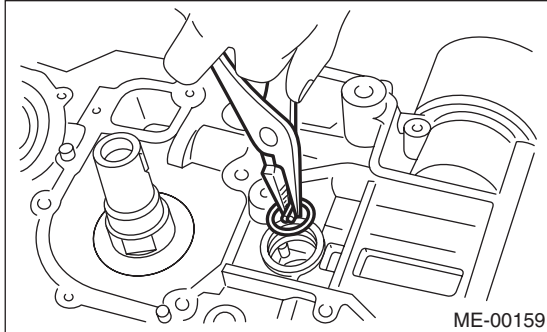

- (4) Apply liquid gasket around the service hole plug.

**Liquid gasket:**

**THREE BOND 1105 (Part No. 004403010) or equivalent**

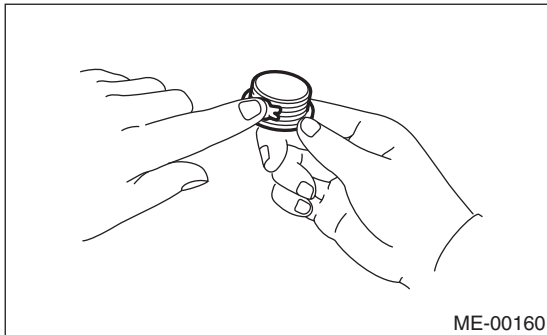

- (5) Install the service hole plug and gasket.

**NOTE:**

Use a new gasket.

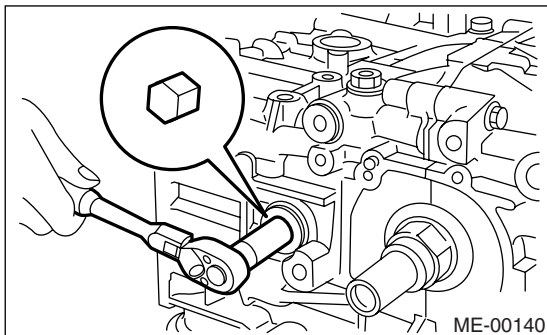

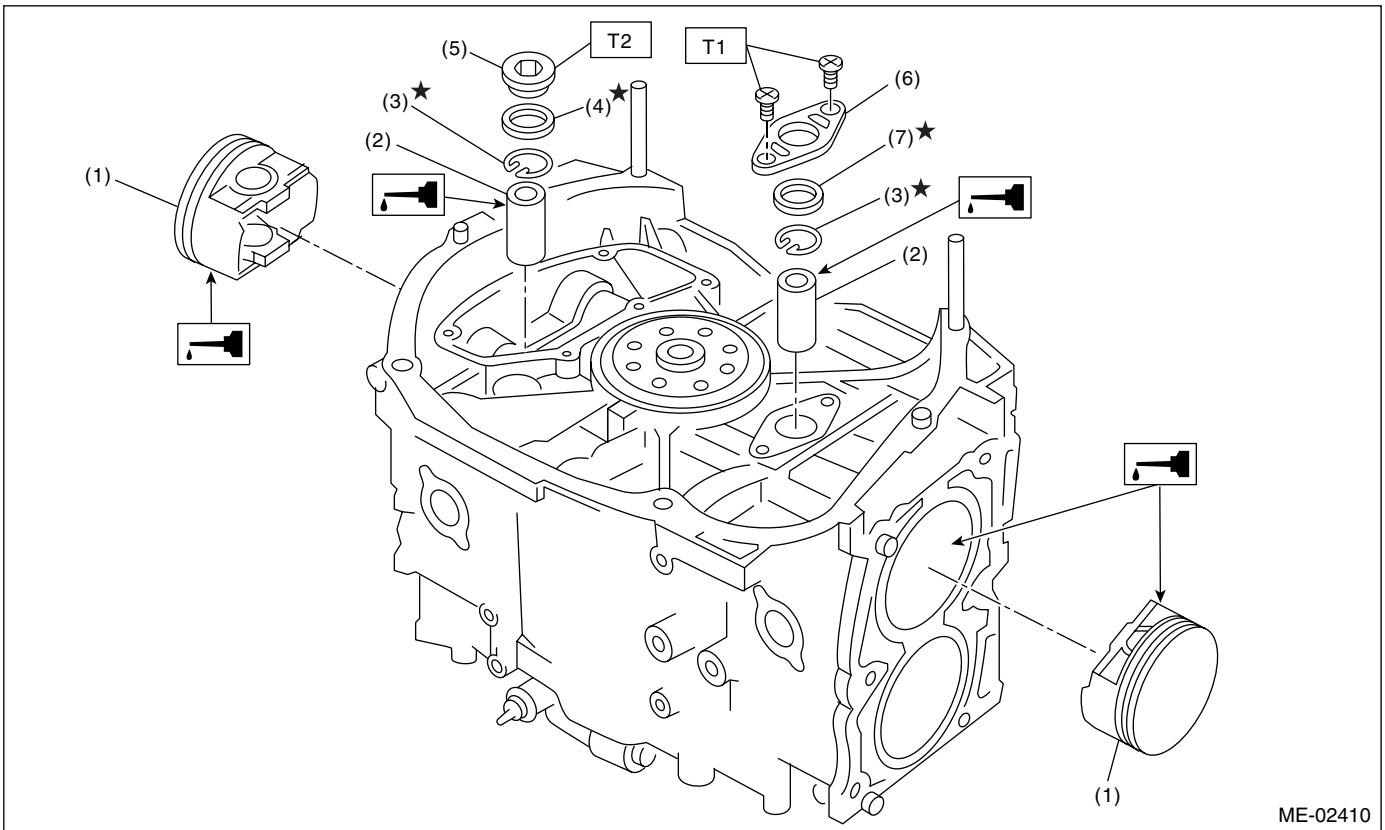

- |                |                        |
|----------------|------------------------|
| (1) Piston     | (5) Service hole plug  |
| (2) Piston pin | (6) Service hole cover |
| (3) Snap ring  | (7) O-ring             |
| (4) Gasket     |                        |

**Tightening torque: N·m (kgf·m, ft·lb)**  
**T1: 6.4 (0.65, 4.7)**  
**T2: 70 (7.1, 51.6)**

- (6) Turn the cylinder block so that #3 and #4 cylinders face upward. Using the same procedures as used for #1 and #2 cylinders, install the pistons and piston pins.
- 22) Install the water pipe.  
 23) Install the baffle plate.

**Tightening torque:**  
**6.4 N·m (0.65 kgf·m, 4.7 ft·lb)**

- 24) Install the oil strainer and O-ring

**Tightening torque:**  
**10 N·m (1.0 kgf·m, 7.4 ft·lb)**

- 25) Install the oil strainer stay.  
 26) Apply liquid gasket to the matching surfaces, and then install the oil pan.

**Liquid gasket:**  
**THREE BOND 1207C (Part No. 004403012) or equivalent**

**Tightening torque:**  
**5 N·m (0.5 kgf·m, 3.6 ft·lb)**

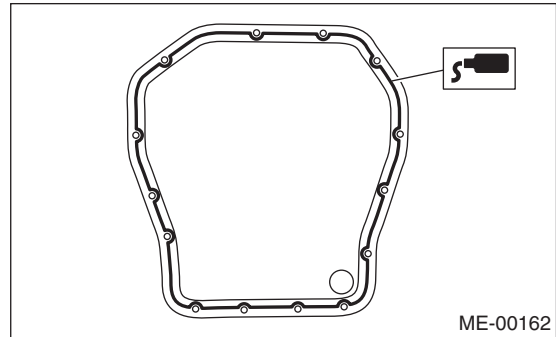

- 27) Apply liquid gasket to the mating surfaces and threaded portion of bolt (A) as shown in the figure, and then install the oil separator cover.

**Liquid gasket:**  
**Mating surface**  
**THREE BOND 1207C (Part No. 004403012) or equivalent**  
**Threaded portion of bolt (A)**  
**THREE BOND 1324 (Part No. 004403042) or equivalent**

# Cylinder Block

MECHANICAL

## Tightening torque:

**6.4 N·m (0.65 kgf-m, 4.7 ft-lb)**

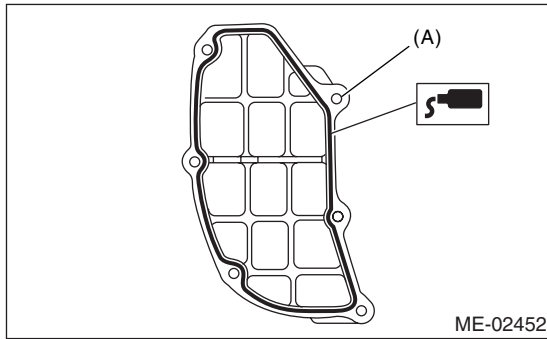

28) Install the flywheel. <Ref. to CL-17, INSTALLATION, Flywheel.>

29) Install the clutch disc and cover. <Ref. to CL-14, INSTALLATION, Clutch Disc and Cover.>

30) Installation of oil pump:

(1) Discard the front oil seal after removal. Replace with a new one using the ST.

ST 499587100 OIL SEAL INSTALLER

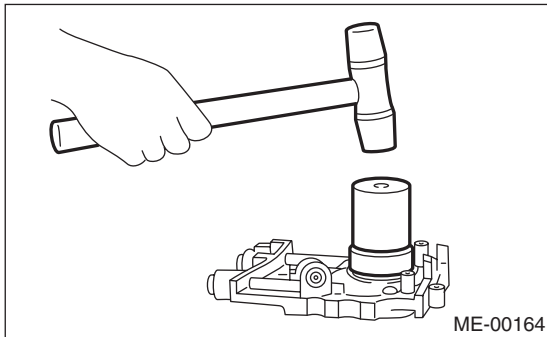

(2) Apply liquid gasket to the matching surface of oil pump.

## Liquid gasket:

**THREE BOND 1215 (Part No. 004403007) or equivalent**

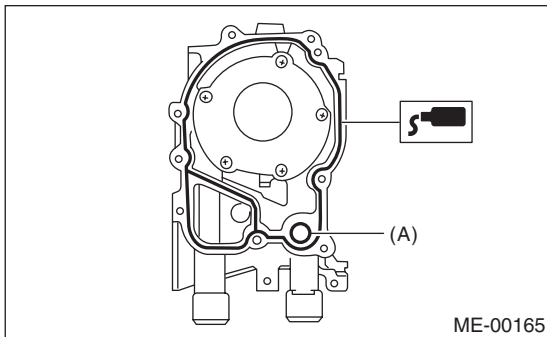

(A) O-ring

(3) Apply a coat of engine oil to the inside of the oil seal.

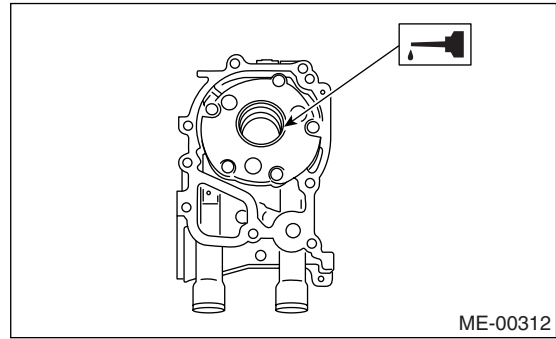

(4) Install the oil pump on cylinder block. Be careful not to damage the oil seal during installation.

(5) Position the oil pump, aligning the notched area with crankshaft, and push the oil pump straight.

## CAUTION:

**Make sure the oil seal lip is not folded.**

(6) Install the oil pump.

(7) Apply liquid gasket to the threaded portion of three bolts.

## Liquid gasket:

**THREE BOND 1324 (Part No. 004403042) or equivalent**

## Tightening torque:

**6.4 N·m (0.65 kgf-m, 4.7 ft-lb)**

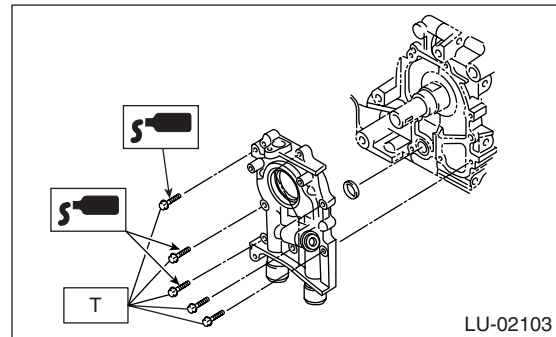

## CAUTION:

- Use new O-ring and seal.
- Do not forget to install the O-ring and seal when installing the oil pump.

31) Install the water pump and gasket.

## Tightening torque:

**First; 12 N·m (1.2 kgf-m, 8.7 ft-lb)**

**Second; 12 N·m (1.2 kgf-m, 8.7 ft-lb)**

**CAUTION:**

- Be sure to use a new gasket.
- When installing the water pump, tighten the bolts in two stages in alphabetical sequence as shown in the figure.

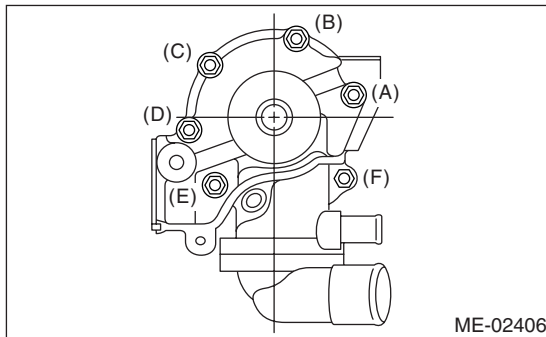

- 32) Install the water by-pass pipe for heater.  
 33) Install the oil cooler.

**CAUTION:**

Always use a new O-ring.

**Tightening torque:**

- T1: 54 N·m (5.5 kgf-m, 40 ft-lb)**  
**T2: 69 N·m (7.0 kgf-m, 50.9 ft-lb)**  
**T3: 6.4 N·m (0.65 kgf-m, 4.7 ft-lb)**

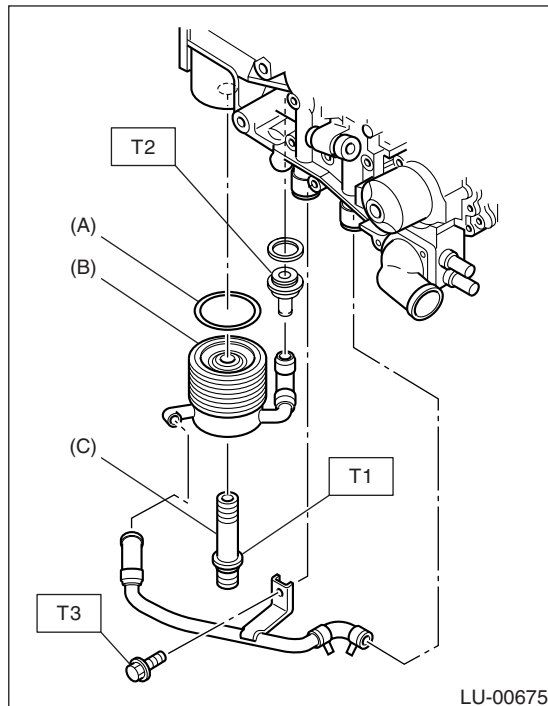

- (A) O-ring  
 (B) Oil cooler  
 (C) Oil cooler connector

- 34) Install the oil filter using ST.  
 ST 18332AA000 OIL FILTER WRENCH (Outer diameter: 68 mm (2.68 in))

ST 18332AA010 OIL FILTER WRENCH (Outer diameter: 65 mm (2.56 in))

**NOTE:**

- Standard oil filter is outer diameter of 68 mm (2.68 in). However, SUBARU genuine oil filter having outer diameter of 65 mm (2.56 in) can also be used.
- Install the oil filter by turning it by hand, being careful not to damage the seal rubber.
- Tighten the oil filter 68 mm (2.68 in) in diameter by approx. 1 rotation more after the seal rubber of oil filter comes in contact with oil cooler. If using a torque wrench, tighten it to 14 N·m (1.4 kgf-m, 10.3 ft-lb).
- Tighten the oil filter 65 mm (2.56 in) in diameter by approx. 2/3 — 3/4 rotation more after the seal rubber of oil filter comes in contact with oil cooler. If using a torque wrench, tighten it to 12 N·m (1.2 kgf-m, 8.7 ft-lb).

**CAUTION:**

Do not tighten excessively, or oil may leak.

- 35) Install the water by-pass pipe between oil cooler and water pump.  
 36) Install the water pipe.

**NOTE:**

Always use a new O-ring.

- 37) Install the cylinder head. <Ref. to ME(STI)-60, INSTALLATION, Cylinder Head.>  
 38) Install the oil level gauge guide and tighten the attaching bolt (LH side).  
 39) Install the rocker cover.

**NOTE:**

Be sure to use a new gasket of rocker cover.

- 40) Install the crank sprocket. <Ref. to ME(STI)-53, INSTALLATION, Crank Sprocket.>  
 41) Install the cam sprocket. <Ref. to ME(STI)-52, INSTALLATION, Cam Sprocket.>  
 42) Install the timing belt. <Ref. to ME(STI)-45, INSTALLATION, Timing Belt.>  
 43) Install the timing belt cover. <Ref. to ME(STI)-43, INSTALLATION, Timing Belt Cover.>  
 44) Install the crank pulley. <Ref. to ME(STI)-42, INSTALLATION, Crank Pulley.>  
 45) Install the generator and A/C compressor brackets on cylinder head.  
 46) Install the V-belt. <Ref. to ME(STI)-40, INSTALLATION, V-belt.>  
 47) Install the intake manifold. <Ref. to FU(STI)-13, REMOVAL, Intake Manifold.>

# Cylinder Block

MECHANICAL

## C: DISASSEMBLY

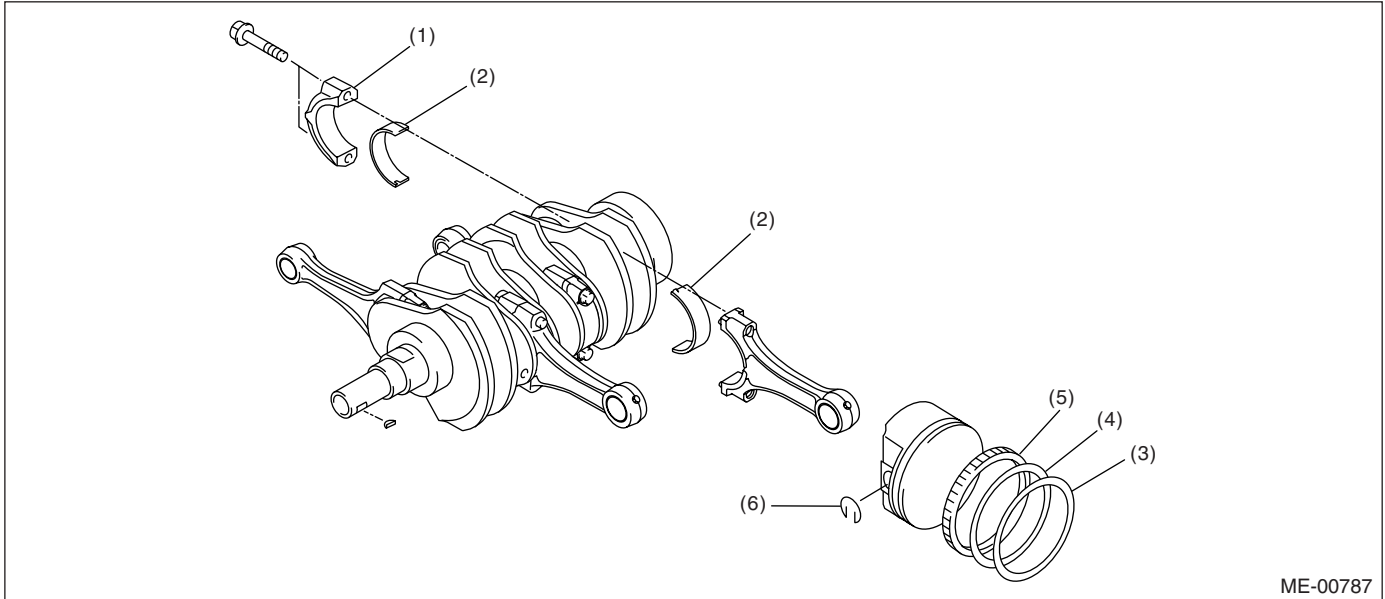

- |                            |                 |               |
|----------------------------|-----------------|---------------|
| (1) Connecting rod cap     | (3) Top ring    | (5) Oil ring  |
| (2) Connecting rod bearing | (4) Second ring | (6) Snap ring |

- 1) Remove the connecting rod cap.
- 2) Remove the connecting rod bearing.

**NOTE:**

Arrange the removed connecting rod, connecting rod cap and bearing in order to prevent confusion.

3) Remove the piston rings using the piston ring expander.

- 4) Remove the oil ring by hand.

**NOTE:**

Arrange the removed piston rings in proper order to prevent confusion.

- 5) Remove the snap ring.

## D: ASSEMBLY

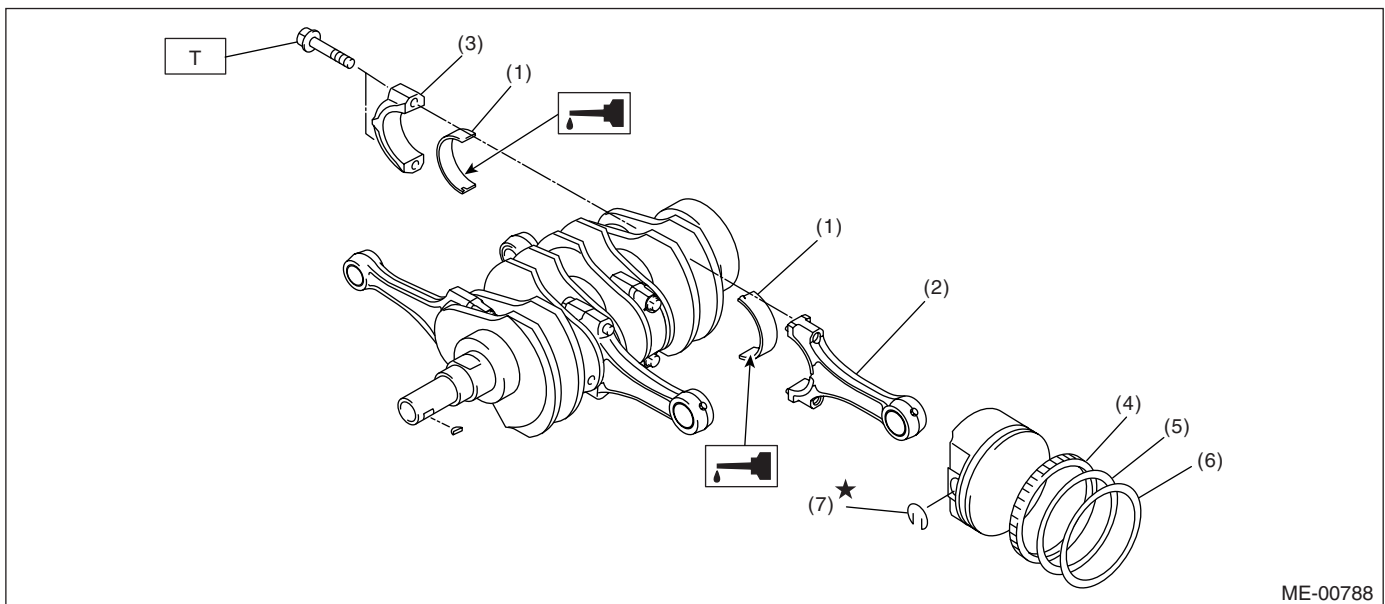

- |                            |                 |
|----------------------------|-----------------|
| (1) Connecting rod bearing | (5) Second ring |
| (2) Connecting rod         | (6) Top ring    |
| (3) Connecting rod cap     | (7) Snap ring   |
| (4) Oil ring               |                 |

**Tightening torque: N·m (kgf·m, ft·lb)**

**T: 52 (5.3, 38.4)**

- 1) Apply oil to the surfaces of the connecting rod bearings. Install the connecting rod bearings on connecting rods and connecting rod caps.
- 2) Install the connecting rod on crankshaft.

**NOTE:**

Position each connecting rod with the side marked facing forward.

- 3) Install the connecting rod cap. Ensure the arrow on connecting rod cap faces the front during installation.

**CAUTION:**

- Each connecting rod has its own mating cap. Make sure that they are assembled correctly by checking their matching number.
- When tightening the connecting rod nuts, apply oil on the threads.

- 4) Install the oil ring spacer, upper rail and lower rail in this order by hand. Then install the second ring and top ring with a piston ring expander.

## E: INSPECTION

### 1. CYLINDER BLOCK

- 1) Visually check for cracks and damage. Especially, inspect the important parts by means of liquid penetrant tester.
- 2) Check the oil passages for clogging.
- 3) Inspect the crankcase surface that mates with cylinder head for warping by using a straight edge, and correct by grinding if necessary.

**Warping limit:**  
**0.025 mm (0.00098 in)**

**Grinding limit:**  
**0.1 mm (0.004 in)**

**Standard height of cylinder block:**  
**201.0 mm (7.91 in)**

### 2. CYLINDER AND PISTON

- 1) The cylinder bore size is stamped on cylinder block's front upper surface.

**NOTE:**

- Measurement should be performed at a temperature of 20°C (68°F).
- Standard sized pistons are classified into two grades, "A" and "B". These grades should be used as a guide line in selecting a standard piston.

**Standard inner diameter:**

**A: 99.505 — 99.515 mm (3.9175 — 3.9179 in)**

**B: 99.495 — 99.505 mm (3.9171 — 3.9175 in)**

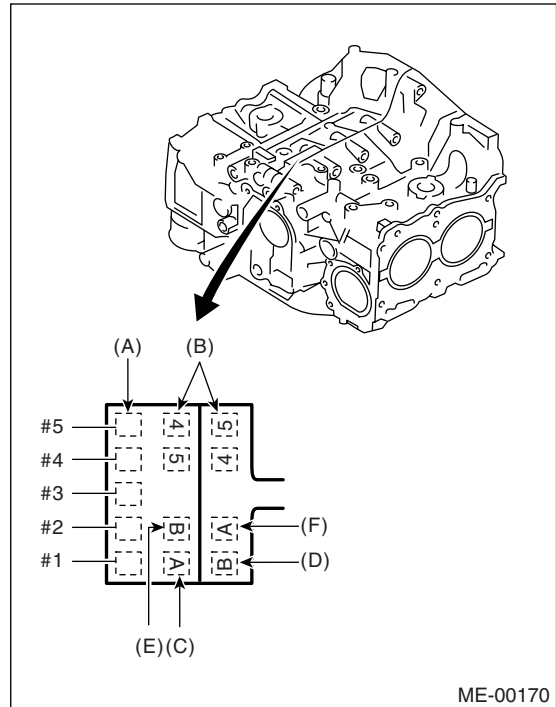

- (A) Main journal size mark
- (B) Cylinder block (RH)-(LH) combination mark
- (C) #1 cylinder bore size mark
- (D) #2 cylinder bore size mark
- (E) #3 cylinder bore size mark
- (F) #4 cylinder bore size mark

- 2) How to measure the inner diameter of each cylinder

Measure the inner diameter of each cylinder in both the thrust and piston pin directions at the heights shown in the figure, using a cylinder bore gauge.

**NOTE:**

Measurement should be performed at a temperature of 20°C (68°F).



# Cylinder Block

MECHANICAL

## Taper:

### Standard

0.015 mm (0.0006 in)

### Limit

0.050 mm (0.0020 in)

## Out-of-roundness:

### Standard

0.010 mm (0.0004 in)

### Limit

0.050 mm (0.0020 in)

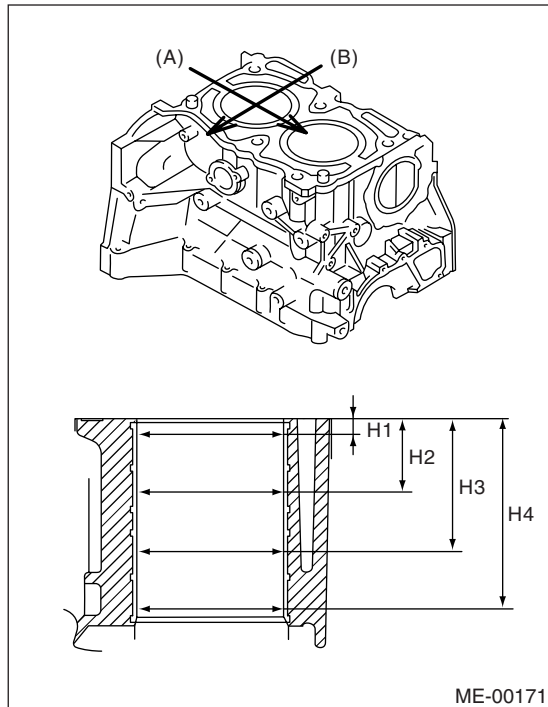

(A) Piston pin direction

(B) Thrust direction

H1: 10 mm (0.39 in)

H2: 45 mm (1.77 in)

H3: 80 mm (3.15 in)

H4: 115 mm (4.53 in)

3) When the piston is to be replaced due to general or cylinder wear, determine a suitable sized piston by measuring the piston clearance.

4) How to measure the outer diameter of each piston:

Measure the outer diameter of each piston at the height shown in the figure. (Thrust direction)

## NOTE:

Measurement should be performed at a temperature of 20°C (68°F).

## Piston grade point H:

38.2 mm (1.50 in)

## Piston outer diameter:

### Standard

A: 99.505 — 99.515 mm (3.9175 — 3.9179 in)

B: 99.495 — 99.505 mm (3.9171 — 3.9175 in)

### 0.25 mm (0.0098 in) oversize

99.745 — 99.765 mm (3.9270 — 3.9278 in)

### 0.50 mm (0.0197 in) oversize

99.995 — 100.015 mm (3.9368 — 3.9376 in)

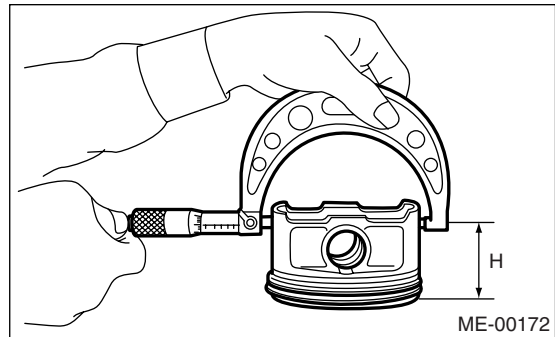

5) Calculate the clearance between cylinder and piston.

## NOTE:

Measurement should be performed at a temperature of 20°C (68°F).

## Cylinder to piston clearance at 20°C (68°F):

### Standard

-0.010 — 0.010 mm (-0.0004 — 0.0004 in)

### Limit

0.030 mm (0.0012 in)

6) Boring and honing

(1) If the measured value of either taper, out-of-roundness, or cylinder-to-piston clearance exceeds the specified limit, or if there is any damage on the cylinder wall, reboring it to use an oversize piston.

## CAUTION:

**When any of the cylinders needs reboring, all other cylinders must be bored at the same time, and use oversize pistons. Do not perform boring on one cylinder only, nor use an oversize piston for one cylinder only.**

(2) If the cylinder inner diameter exceeds the limit after boring and honing, replace the crankcase.

## NOTE:

Immediately after reboring, the cylinder diameter may differ from its real diameter due to temperature rise. Thus, pay attention to this when measuring the cylinder diameter.

## Cylinder enlarging (boring) limit (dia.):

To 100.005 mm (3.937 in)



### 3. PISTON AND PISTON PIN

- 1) Check the pistons and piston pins for damage, cracks, and wear and the piston ring grooves for wear and damage. Replace if defective.
- 2) Measure the piston-to-cylinder clearance at each cylinder. <Ref. to ME(STI)-79, CYLINDER AND PISTON, INSPECTION, Cylinder Block.> If any of the clearances is not within specification, replace the piston or bore the cylinder to use an over-size piston.
- 3) Make sure that the piston pin can be inserted into the piston pin hole with a thumb at 20°C (68°F). Replace if defective.

**Standard clearance between piston pin and hole in piston:**

**Standard**

**0.004 — 0.008 mm (0.0002 — 0.0003 in)**

**Limit**

**0.020 mm (0.0008 in)**

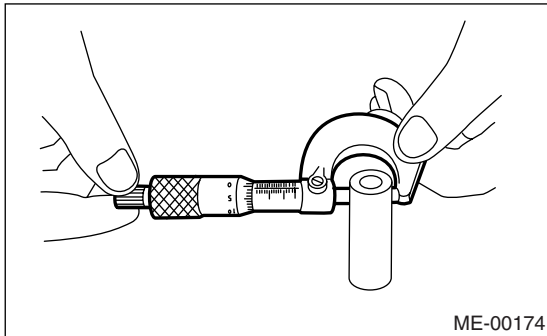
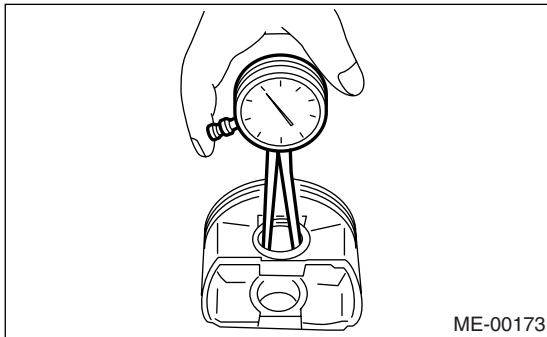

- 4) Check the snap ring installation groove (A) on piston for burr. If necessary, remove the burr from groove so that the piston pin can lightly move.

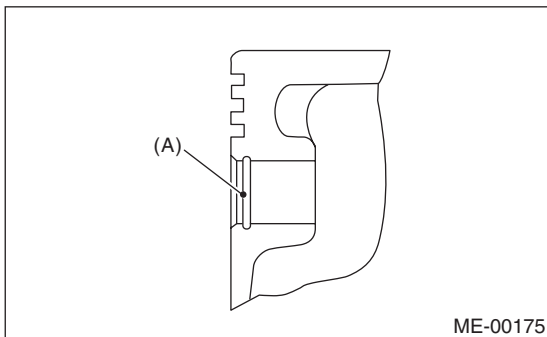

- 5) Check the piston pin snap ring for distortion, cracks and wear.

### 4. PISTON RING

- 1) If the piston ring is broken, damaged, or worn, or if its tension is insufficient, or when the piston is replaced, replace the piston ring with a new one of the same size as the piston.

**NOTE:**

- Marks are shown on the end of top and second rings. When installing the rings to piston, face this mark upward.
- Oil ring consists of upper rail, expander and lower rail. When installing on piston, be careful of each rail's direction.

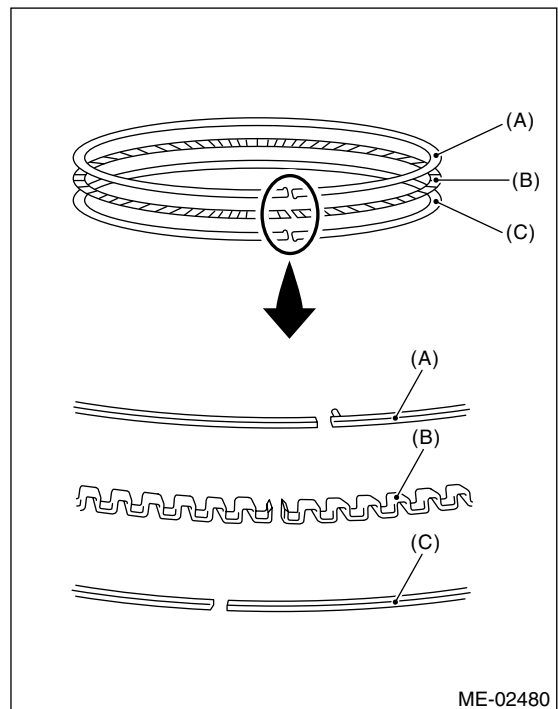

- (A) Upper rail
- (B) Expander
- (C) Lower rail

# Cylinder Block

## MECHANICAL

2) Squarely place the piston ring and oil ring in cylinder, and then measure the piston ring closed gap with a thickness gauge.

		Unit: mm (in)	
		Standard	Limit
Piston ring closed gap	Top ring	0.20 — 0.25 (0.0079 — 0.0098)	1.0 (0.039)
	Second ring	0.37 — 0.52 (0.015 — 0.020)	1.0 (0.039)
	Oil ring rail	0.20 — 0.50 (0.0079 — 0.0197)	1.5 (0.059)

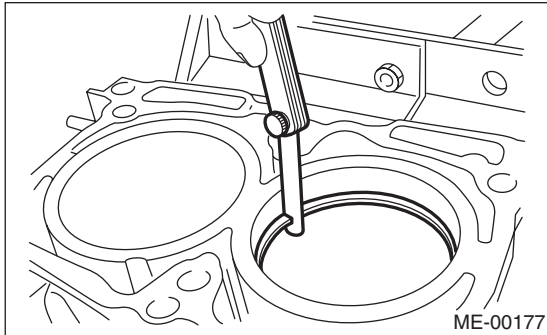

3) Measure the clearance between piston ring and piston ring groove with a thickness gauge.

### NOTE:

Before measuring the clearance, clean the piston ring groove and piston ring.

		Unit: mm (in)	
		Standard	Limit
Clearance between piston ring and piston ring groove	Top ring	0.040 — 0.080 (0.0016 — 0.0031)	0.15 (0.0059)
	Second ring	0.030 — 0.070 (0.0012 — 0.0028)	0.15 (0.0059)

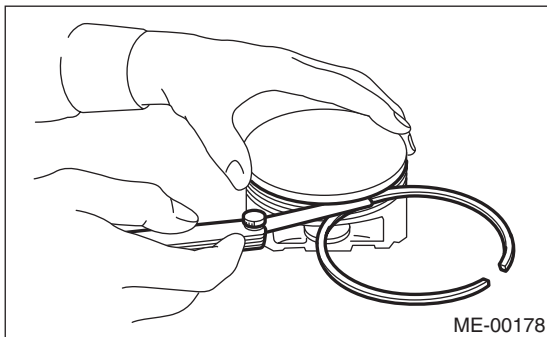

## 5. CONNECTING ROD

- 1) Replace the connecting rod, if the large or small end thrust surface is damaged.
- 2) Check for bend or twist using a connecting rod aligner. Replace the connecting rod if the bend or twist exceeds the limit.

**Limit of bend or twist per 100 mm (3.94 in) in length:**  
**0.10 mm (0.0039 in)**

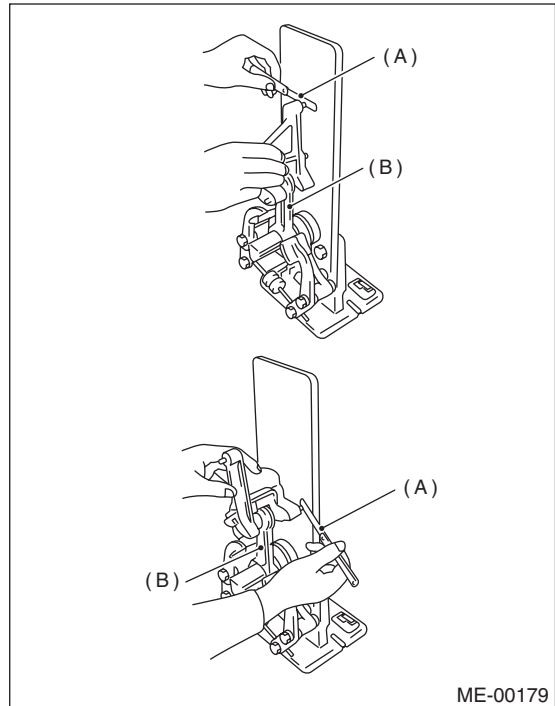

- (A) Thickness gauge  
 (B) Connecting rod

3) Install the connecting rod fitted with bearing to crankshaft, and then measure the side clearance (thrust clearance). Replace the connecting rod if the side clearance exceeds the specified limit.

### Connecting rod side clearance:

#### Standard

**0.070 — 0.330 mm (0.0028 — 0.0130 in)**

#### Limit

**0.40 mm (0.016 in)**

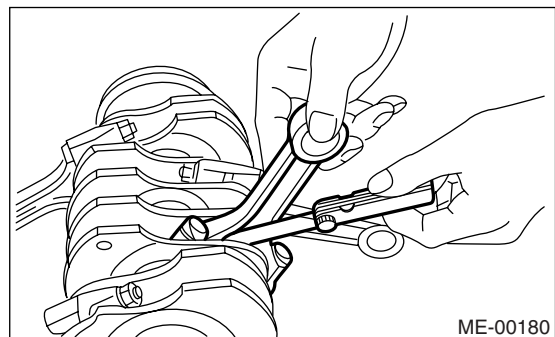

- 4) Inspect the connecting rod bearing for scar, peeling, seizure, melting, wear, etc.
- 5) Measure the oil clearance on individual connecting rod bearings by means of plastigauge. If any oil clearance is not within specification, replace the defective bearing with a new one of standard size or undersize as necessary. (See the table below.)

**Connecting rod oil clearance:**

**Standard**

**0.017 — 0.045 mm (0.0007 — 0.0018 in)**

**Limit**

**0.050 mm (0.0020 in)**

Unit: mm (in)		
Bearing	Bearing size (Thickness at center)	Outer diameter of crank pin
Standard	1.490 — 1.502 (0.0587 — 0.0591)	51.984 — 52.000 (2.0466 — 2.0472)
0.03 (0.0012) undersize	1.504 — 1.512 (0.0592 — 0.0595)	51.954 — 51.970 (2.0454 — 2.0461)
0.05 (0.0020) undersize	1.514 — 1.522 (0.0596 — 0.0599)	51.934 — 51.950 (2.0447 — 2.0453)
0.25 (0.0098) undersize	1.614 — 1.622 (0.0635 — 0.0639)	51.734 — 51.750 (2.0368 — 2.0374)

- 6) Inspect the bushing at connecting rod small end, and replace if worn or damaged. Also measure the piston pin clearance at connecting rod small end.

**Clearance between piston pin and bushing:**

**Standard**

**0 — 0.022 mm (0 — 0.0009 in)**

**Limit**

**0.030 mm (0.0012 in)**

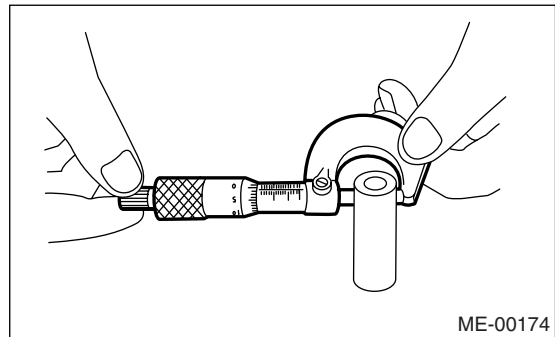
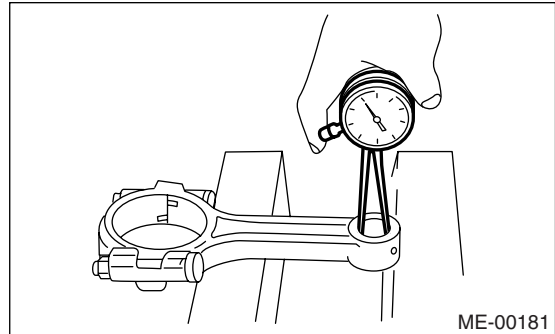

- 7) Replacement procedure is as follows:
  - (1) Remove the bushing from connecting rod with ST and press.
  - (2) Press the bushing with ST after applying oil on the periphery of bushing.

ST 499037100 CONNECTING ROD BUSHING REMOVER AND INSTALLER

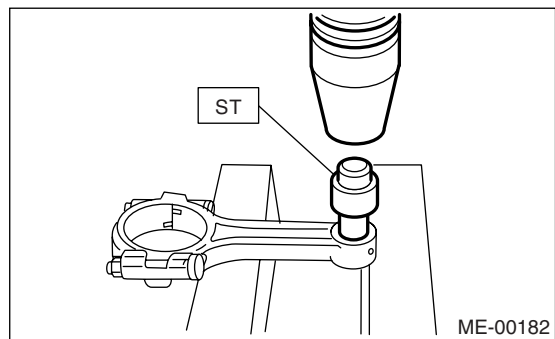

- (3) Make two 3 mm (0.12 in) holes in bushing. Ream the inside of bushing.
- (4) After the completion of reaming, clean the bushing to remove chips.

# Cylinder Block

MECHANICAL

## 6. CRANKSHAFT AND CRANKSHAFT BEARING

- 1) Clean the crankshaft completely and check for cracks by means of liquid penetrant tester etc., and replace if defective.
- 2) Measure the crankshaft bend, and correct or replace if it exceeds the limit.

### NOTE:

If a suitable V-block is not available, install the #1 and #5 crankshaft bearing on cylinder block, position the crankshaft on these bearings and measure the crankshaft bend using a dial gauge.

**Crankshaft bend limit:**  
**0.035 mm (0.0014 in)**

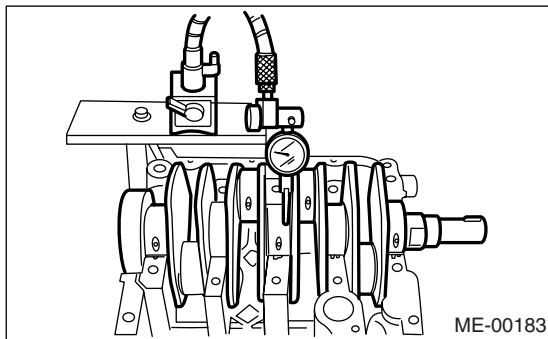

- 3) Inspect the crank journal and crank pin for wear. If they are not within the specifications, replace the bearing with a suitable (undersize) one, and then replace or recondition the crankshaft as necessary. When grinding the crank journal or crank pin, finish them to specified dimensions according to the undersize bearing to be used.

### Crank pin:

**Out-of-roundness**

**0.003 mm (0.0001 in)**

**Cylindricality**

**0.004 mm (0.0002 in)**

**Grinding limit**

**To 51.750 mm (2.0374 in) dia.**

### Crank journal:

**Out-of-roundness**

**0.005 mm (0.0002 in)**

**Cylindricality**

**0.006 mm (0.0002 in)**

**Grinding limit**

**To 59.750 mm (2.3524 in) dia.**

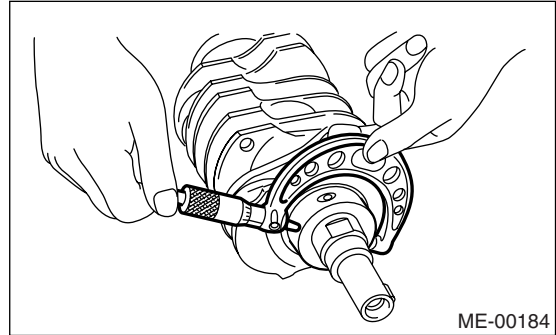

# Cylinder Block

MECHANICAL

		Crank journal diameter		Unit: mm (in)
		#1, #3	#2, #4, #5	Crank pin outer diameter
Standard	Journal O.D.	59.992 — 60.008 (2.3619 — 2.3625)	59.992 — 60.008 (2.3619 — 2.3625)	51.984 — 52.000 (2.0466 — 2.0472)
	Bearing size (Thickness at center)	1.998 — 2.011 (0.0787 — 0.0792)	2.000 — 2.013 (0.0787 — 0.0793)	1.490 — 1.502 (0.0587 — 0.0591)
0.03 (0.0012) undersize	Journal O.D.	59.962 — 59.978 (2.3607 — 2.3613)	59.962 — 59.978 (2.3607 — 2.3613)	51.954 — 51.970 (2.0454 — 2.0461)
	Bearing size (Thickness at center)	2.017 — 2.020 (0.0794 — 0.0795)	2.019 — 2.022 (0.0795 — 0.0796)	1.504 — 1.512 (0.0592 — 0.0595)
0.05 (0.0020) undersize	Journal O.D.	59.942 — 59.958 (2.3599 — 2.3605)	59.942 — 59.958 (2.3599 — 2.3605)	51.934 — 51.950 (2.0447 — 2.0453)
	Bearing size (Thickness at center)	2.027 — 2.030 (0.0798 — 0.0799)	2.029 — 2.032 (0.0799 — 0.0800)	1.514 — 1.522 (0.0596 — 0.0599)
0.25 (0.0098) undersize	Journal O.D.	59.742 — 59.758 (2.3520 — 2.3527)	59.742 — 59.758 (2.3520 — 2.3527)	51.734 — 51.750 (2.0368 — 2.0374)
	Bearing size (Thickness at center)	2.127 — 2.130 (0.0837 — 0.0839)	2.129 — 2.132 (0.0838 — 0.0839)	1.614 — 1.622 (0.0635 — 0.0639)

O.D.: Outer Diameter

4) Measure the thrust clearance of crankshaft at center bearing. If the clearance exceeds the limit, replace the bearing.

**Crankshaft side clearance:**

**Standard**

**0.030 — 0.115 mm (0.0012 — 0.0045 in)**

**Limit**

**0.25 mm (0.0098 in)**

**Crankshaft oil clearance:**

**Standard**

**0.010 — 0.030 mm (0.0004 — 0.0012 in)**

**Limit**

**0.040 mm (0.0016 in)**

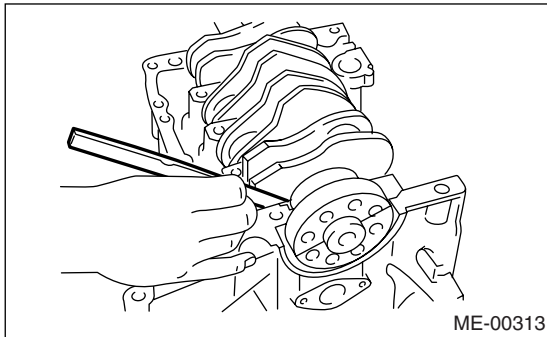

5) Inspect individual crankshaft bearings for signs of flaking, seizure, melting, and wear.

6) Measure the oil clearance on each crankshaft bearing by means of plastigauge. If the measurement is not within the specification, replace the defective bearing with an undersize one, and replace or recondition the crankshaft as necessary.

## 21.Intake and Exhaust Valve

### A: SPECIFICATION

For the removal and installation procedure of intake and exhaust valve, refer to "Cylinder Head". <Ref. to ME(STI)-60, REMOVAL, Cylinder Head.> and <Ref. to ME(STI)-60, INSTALLATION, Cylinder Head.>

## 22.Piston

### A: SPECIFICATION

For the removal and installation procedure of piston, refer to "Cylinder Block". <Ref. to ME(STI)-67, REMOVAL, Cylinder Block.> and <Ref. to ME(STI)-70, INSTALLATION, Cylinder Block.>

## 23.Connecting Rod

### A: SPECIFICATION

For the removal and installation procedure of connecting rod, refer to "Cylinder Block". <Ref. to ME(STI)-67, REMOVAL, Cylinder Block.> and <Ref. to ME(STI)-70, INSTALLATION, Cylinder Block.>



## 24.Crankshaft

### A: SPECIFICATION

For the removal and installation procedure of crankshaft, refer to "Cylinder Block". <Ref. to ME(STI)-67, REMOVAL, Cylinder Block.> and <Ref. to ME(STI)-70, INSTALLATION, Cylinder Block.>

# Engine Trouble in General

MECHANICAL

## 25.Engine Trouble in General

### A: INSPECTION

NOTE:

“RANK” shown in the chart refers to the possibility of reason for the trouble in order (“Very often” to “Rarely”)

A — Very often

B — Sometimes

C — Rarely

TROUBLE	PROBLEM PARTS, ETC.	POSSIBLE CAUSE	RANK
1. Engine does not start.			
1) Starter does not turn.	Starter	Defective battery-to-starter harness	B
		Defective starter switch	C
		Defective inhibitor switch or neutral switch	C
		Defective starter	B
	Battery	Poor terminal connection	A
		Run-down battery	A
		Defective charging system	B
	Friction	Seizure of crankshaft and connecting rod bearing	C
		Seized camshaft	C
Seized or stuck piston and cylinder		C	
2) Initial combustion does not occur.	Starter	Defective starter	C
	Engine control system <Ref. to EN(STI)(diag)-2, Basic Diagnostic Procedure.>		A
	Fuel line	Defective fuel pump and relay	A
		Lack of or insufficient fuel	B
	Belt	Defective	B
		Defective timing	B
	Compression	Incorrect valve clearance	C
		Loosened spark plugs or defective gasket	C
		Loosened cylinder head bolts or defective gasket	C
		Improper valve sealing	C
		Defective valve stem	C
		Worn or broken valve spring	B
		Worn or stuck piston rings, cylinder and piston	C
		Incorrect valve timing	B
Improper engine oil (low viscosity)	B		
3) Initial combustion occurs.	Engine control system <Ref. to EN(STI)(diag)-2, Basic Diagnostic Procedure.>		A
	Intake system	Defective intake manifold gasket	B
		Defective throttle body gasket	B
	Fuel line	Defective fuel pump and relay	C
		Clogged fuel line	C
		Lack of or insufficient fuel	B
	Belt	Defective	B
		Defective timing	B
	Compression	Incorrect valve clearance	C
		Loosened spark plugs or defective gasket	C
		Loosened cylinder head bolts or defective gasket	C
		Improper valve sealing	C
		Defective valve stem	C
		Worn or broken valve spring	B
Worn or stuck piston rings, cylinder and piston		C	
Incorrect valve timing		B	
Improper engine oil (low viscosity)	B		

# Engine Trouble in General

MECHANICAL

TROUBLE	PROBLEM PARTS, ETC.	POSSIBLE CAUSE	RANK
4) Engine stalls after initial combustion.	Engine control system <Ref. to EN(STI)(diag)-2, Basic Diagnostic Procedure.>		A
	Intake system	Loosened or cracked intake duct	B
		Loosened or cracked PCV hose	C
		Loosened or cracked vacuum hose	C
		Defective intake manifold gasket	B
		Defective throttle body gasket	B
		Dirty air cleaner element	C
	Fuel line	Clogged fuel line	C
		Lack of or insufficient fuel	B
	Belt	Defective	B
		Defective timing	B
	Compression	Incorrect valve clearance	C
		Loosened spark plugs or defective gasket	C
		Loosened cylinder head bolts or defective gasket	C
		Improper valve sealing	C
		Defective valve stem	C
		Worn or broken valve spring	B
Worn or stuck piston rings, cylinder and piston		C	
Incorrect valve timing		B	
Improper engine oil (low viscosity)		B	
2. Rough idle and engine stall	Engine control system <Ref. to EN(STI)(diag)-2, Basic Diagnostic Procedure.>		A
	Intake system	Loosened or cracked intake duct	A
		Loosened or cracked PCV hose	A
		Loosened or cracked vacuum hose	A
		Defective intake manifold gasket	B
		Defective throttle body gasket	B
		Defective PCV valve	C
		Loosened oil filler cap	B
		Dirty air cleaner element	C
	Fuel line	Defective fuel pump and relay	C
		Clogged fuel line	C
		Lack of or insufficient fuel	B
	Belt	Defective timing	C
	Compression	Incorrect valve clearance	B
		Loosened spark plugs or defective gasket	B
		Loosened cylinder head bolts or defective gasket	B
		Improper valve sealing	B
		Defective valve stem	C
		Worn or broken valve spring	B
		Worn or stuck piston rings, cylinder and piston	B
		Incorrect valve timing	A
		Improper engine oil (low viscosity)	B
	Lubrication system	Incorrect oil pressure	B
		Defective rocker cover gasket	C
	Cooling system	Overheating	C
	Others	Malfunction of evaporative emission control system	A
		Stuck or damaged throttle valve	B

# Engine Trouble in General

MECHANICAL

TROUBLE	PROBLEM PARTS, ETC.	POSSIBLE CAUSE	RANK
3. Low output, hesitation and poor acceleration	Engine control system <Ref. to EN(STI)(diag)-2, Basic Diagnostic Procedure.>		A
	Intake system	Loosened or cracked intake duct	A
		Loosened or cracked PCV hose	A
		Loosened or cracked vacuum hose	B
		Defective intake manifold gasket	B
		Defective throttle body gasket	B
		Defective PCV valve	B
		Loosened oil filler cap	B
		Dirty air cleaner element	A
	Fuel line	Defective fuel pump and relay	B
		Clogged fuel line	B
		Lack of or insufficient fuel	C
	Belt	Defective timing	B
	Compression	Incorrect valve clearance	B
		Loosened spark plugs or defective gasket	B
		Loosened cylinder head bolts or defective gasket	B
		Improper valve sealing	B
		Defective valve stem	C
		Worn or broken valve spring	B
		Worn or stuck piston rings, cylinder and piston	C
		Incorrect valve timing	A
	Improper engine oil (low viscosity)	B	
	Lubrication system	Incorrect oil pressure	B
	Cooling system	Overheating	C
		Over cooling	C
	Others	Malfunction of evaporative emission control system	A
	4. Surging	Engine control system <Ref. to EN(STI)(diag)-2, Basic Diagnostic Procedure.>	
Intake system		Loosened or cracked intake duct	A
		Loosened or cracked PCV hose	A
		Loosened or cracked vacuum hose	A
		Defective intake manifold gasket	B
		Defective throttle body gasket	B
		Defective PCV valve	B
		Loosened oil filler cap	B
		Dirty air cleaner element	B
Fuel line		Defective fuel pump and relay	B
		Clogged fuel line	B
		Lack of or insufficient fuel	C
Belt		Defective timing	B
Compression		Incorrect valve clearance	B
		Loosened spark plugs or defective gasket	C
		Loosened cylinder head bolts or defective gasket	C
		Improper valve sealing	C
		Defective valve stem	C
		Worn or broken valve spring	C
		Worn or stuck piston rings, cylinder and piston	C
		Incorrect valve timing	A
Improper engine oil (low viscosity)		B	
Cooling system		Overheating	B
Others		Malfunction of evaporative emission control system	C

# Engine Trouble in General

MECHANICAL

TROUBLE	PROBLEM PARTS, ETC.	POSSIBLE CAUSE	RANK
5. Engine does not return to idle.	Engine control system <Ref. to EN(STI)(diag)-2, Basic Diagnostic Procedure.>		A
	Intake system	Loosened or cracked vacuum hose	A
	Others	Stuck or damaged throttle valve	A
6. Dieseling (Run-on)	Engine control system <Ref. to EN(STI)(diag)-2, Basic Diagnostic Procedure.>		A
	Cooling system	Overheating	B
	Others	Malfunction of evaporative emission control system	B
7. Afterburning in exhaust system	Engine control system <Ref. to EN(STI)(diag)-2, Basic Diagnostic Procedure.>		A
	Intake system	Loosened or cracked intake duct	C
		Loosened or cracked PCV hose	C
		Loosened or cracked vacuum hose	B
		Defective PCV valve	B
		Loosened oil filler cap	C
	Belt	Defective timing	B
	Compression	Incorrect valve clearance	B
		Loosened spark plugs or defective gasket	C
		Loosened cylinder head bolts or defective gasket	C
		Improper valve sealing	B
		Defective valve stem	C
		Worn or broken valve spring	C
		Worn or stuck piston rings, cylinder and piston	C
		Incorrect valve timing	A
Lubrication system	Incorrect oil pressure	C	
Cooling system	Over cooling	C	
Others	Malfunction of evaporative emission control system	C	
8. Knocking	Engine control system <Ref. to EN(STI)(diag)-2, Basic Diagnostic Procedure.>		A
	Intake system	Loosened oil filler cap	B
	Belt	Defective timing	B
	Compression	Incorrect valve clearance	C
		Incorrect valve timing	B
	Cooling system	Overheating	A
9. Excessive engine oil consumption	Intake system	Loosened or cracked PCV hose	A
		Defective PCV valve	B
		Loosened oil filler cap	C
	Compression	Defective valve stem	A
		Worn or stuck piston rings, cylinder and piston	A
	Lubrication system	Loosened oil pump attaching bolts and defective gasket	B
		Defective oil filter o-ring	B
		Defective crankshaft oil seal	B
		Defective rocker cover gasket	B
		Loosened oil drain plug or defective gasket	B
	Loosened oil pan fitting bolts or defective oil pan	B	

## Engine Trouble in General

### MECHANICAL

TROUBLE	PROBLEM PARTS, ETC.	POSSIBLE CAUSE	RANK	
10. Excessive fuel consumption	Engine control system <Ref. to EN(STI)(diag)-2, Basic Diagnostic Procedure.>		A	
	Intake system	Dirty air cleaner element	A	
	Belt	Defective timing	B	
	Compression	Incorrect valve clearance		B
		Loosened spark plugs or defective gasket		C
		Loosened cylinder head bolts or defective gasket		C
		Improper valve sealing		B
		Defective valve stem		C
		Worn or broken valve spring		C
		Worn or stuck piston rings, cylinder and piston		B
		Incorrect valve timing		B
	Lubrication system	Incorrect oil pressure	C	
	Cooling system	Over cooling	C	

## 26.Engine Noise

### A: INSPECTION

Type of sound	Condition	Possible cause
Regular clicking sound	Sound increases as engine speed increases.	<ul style="list-style-type: none"> <li>• Valve mechanism is defective.</li> <li>• Incorrect valve clearance</li> <li>• Worn camshaft</li> <li>• Broken valve spring</li> </ul>
Heavy and dull clank	Oil pressure is low.	<ul style="list-style-type: none"> <li>• Worn crankshaft main bearing</li> <li>• Worn connecting rod bearing (large end)</li> </ul>
	Oil pressure is normal.	<ul style="list-style-type: none"> <li>• Loose flywheel mounting bolts</li> <li>• Damaged engine mounting</li> </ul>
High-pitched clank (Spark knock)	Sound is noticeable when accelerating with an overload.	<ul style="list-style-type: none"> <li>• Ignition timing advanced</li> <li>• Accumulation of carbon inside combustion chamber</li> <li>• Wrong spark plug</li> <li>• Improper gasoline</li> </ul>
Clank when engine speed is medium (1,000 to 2,000 rpm).	Sound is reduced when fuel injector connector of noisy cylinder is disconnected. (NOTE*)	<ul style="list-style-type: none"> <li>• Worn crankshaft main bearing</li> <li>• Worn bearing at crankshaft end of connecting rod</li> </ul>
Knocking sound when engine is operating under idling speed and engine is warm	Sound is reduced when fuel injector connector of noisy cylinder is disconnected. (NOTE*)	<ul style="list-style-type: none"> <li>• Worn cylinder liner and piston ring</li> <li>• Broken or stuck piston ring</li> <li>• Worn piston pin and hole at piston end of connecting rod</li> </ul>
	Sound is not reduced if each fuel injector connector is disconnected in turn. (NOTE*)	<ul style="list-style-type: none"> <li>• Unusually worn valve lifter</li> <li>• Worn cam sprocket</li> <li>• Worn camshaft journal bore in cylinder head assembly</li> </ul>
Squeaky sound	—	<ul style="list-style-type: none"> <li>• Insufficient generator lubrication</li> </ul>
Rubbing sound	—	<ul style="list-style-type: none"> <li>• Defective generator brush and rotor contact</li> </ul>
Gear scream when starting engine	—	<ul style="list-style-type: none"> <li>• Defective ignition starter switch</li> <li>• Worn gear and starter pinion</li> </ul>
Sound like polishing glass with a dry cloth	—	<ul style="list-style-type: none"> <li>• Loose drive belt</li> <li>• Defective water pump shaft</li> </ul>
Hissing sound	—	<ul style="list-style-type: none"> <li>• Loss of compression</li> <li>• Air leakage in air intake system, hoses, connections or manifolds</li> </ul>
Timing belt noise	—	<ul style="list-style-type: none"> <li>• Loose timing belt</li> <li>• Belt contacting case/adjacent part</li> </ul>
Valve noise	—	<ul style="list-style-type: none"> <li>• Incorrect valve clearance</li> </ul>

**NOTE\*:**

When disconnecting the fuel injector connector, Malfunction Indicator Light illuminates and DTC is stored in ECM memory. Therefore, carry out the CLEAR MEMORY MODE <Ref. to EN(STI)(diag)-45, OPERATION, Clear Memory Mode.> and INSPECTION MODE <Ref. to EN(STI)(diag)-36, PROCEDURE, Inspection Mode.> after connecting the fuel injector connector.

# Engine Noise

MECHANICAL

---