

**EMISSION CONTROL
(AUX. EMISSION CONTROL DEVICES)**

General Description

EMISSION CONTROL (AUX. EMISSION CONTROL DEVICES)

1. General Description

A: CAUTION

- Wear work clothing, including a cap, protective goggles and protective shoes during operation.
- Remove contamination including dirt and corrosion before removal, installation or disassembly.
- Keep the disassembled parts in order and protect them from dust and dirt.
- Before removal, installation or disassembly, be sure to clarify the failure. Avoid unnecessary removal, installation, disassembly and replacement.

B: PREPARATION TOOL

- Be careful not to burn your hands, because each part on the vehicle is hot after running.
- Be sure to tighten fasteners including bolts and nuts to the specified torque.
- Place shop jacks or rigid racks at the specified points.
- Before disconnecting electrical connectors of sensors or units, be sure to disconnect the ground cable from battery.

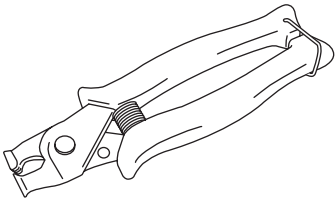
ILLUSTRATION	TOOL NUMBER	DESCRIPTION	REMARKS
 ST18353AA000	18353AA000	CLAMP PLIERS	Used for removing and installing PCV hose.

Front Catalytic Converter

EMISSION CONTROL (AUX. EMISSION CONTROL DEVICES)

2. Front Catalytic Converter

A: REMOVAL

1) Remove the center exhaust pipe. <Ref. to EX(H4DOTC)-10, REMOVAL, Center Exhaust Pipe.>

2) Separate the front catalytic converter (A) from rear catalytic converter (B).

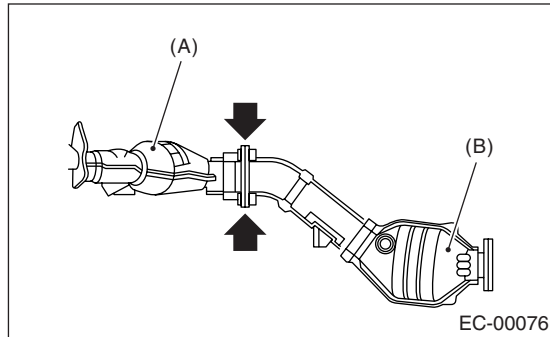

B: INSTALLATION

Install in the reverse order of removal.

NOTE:

Replace the gaskets with new ones.

C: INSPECTION

1) Make sure there are no exhaust leaks from connections and welds.

2) Make sure there are no holes or rusting.

Rear Catalytic Converter

EMISSION CONTROL (AUX. EMISSION CONTROL DEVICES)

3. Rear Catalytic Converter

A: REMOVAL

1) Remove the center exhaust pipe. <Ref. to EX(H4DOTC)-10, REMOVAL, Center Exhaust Pipe.>

2) Separate the rear catalytic converter (B) from front catalytic converter (A).

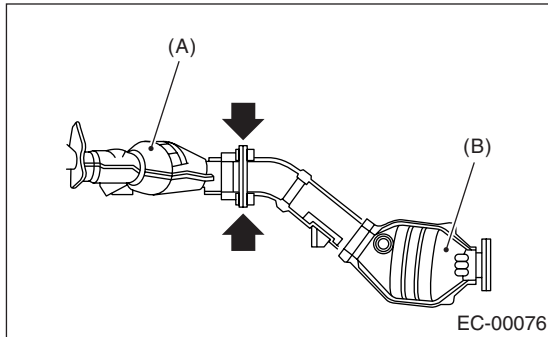

B: INSTALLATION

Install in the reverse order of removal.

NOTE:

Replace the gaskets with new ones.

C: INSPECTION

1) Make sure there are no exhaust leaks from connections and welds.

2) Make sure there are no holes or rusting.

Canister

EMISSION CONTROL (AUX. EMISSION CONTROL DEVICES)

4. Canister

A: REMOVAL

- 1) Disconnect the ground cable from battery.
- 2) Lift up the vehicle.
- 3) Disconnect connector (A) from drain valve.
- 4) Disconnect evaporation hoses (B) and (C) from canister.

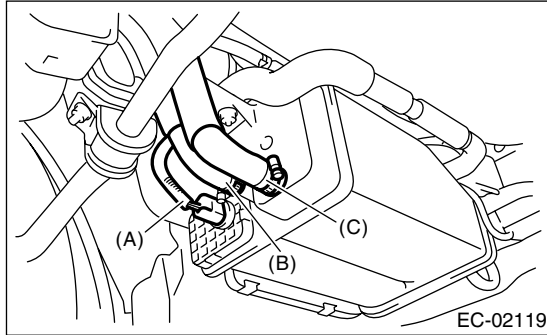

- 5) Disconnect quick connector (A) from canister.
- 6) Disconnect drain hoses (B) from canister.

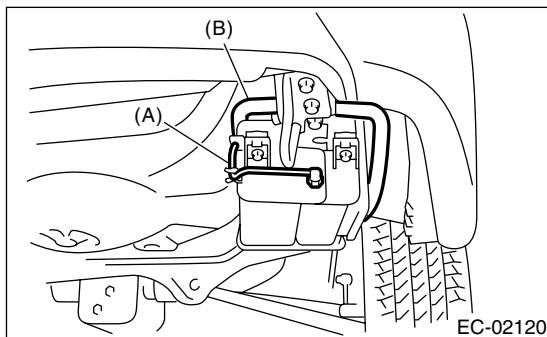

- 7) Remove the canister from vehicle.

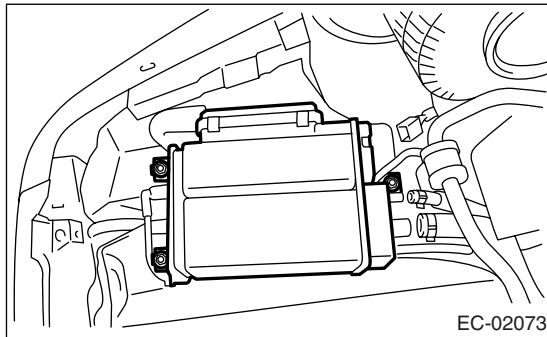

B: INSTALLATION

Install in the reverse order of removal.

NOTE:

Replace the retainer of quick connector with new one.

Tightening torque:

23 N·m (2.3 kgf-m, 17 ft-lb)

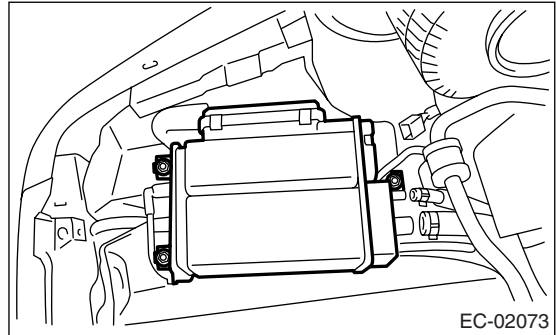

C: INSPECTION

Make sure the canister and canister hoses are not cracked or loose.

Purge Control Solenoid Valve

EMISSION CONTROL (AUX. EMISSION CONTROL DEVICES)

5. Purge Control Solenoid Valve

A: REMOVAL

- 1) Disconnect the ground cable from battery.
- 2) Disconnect the connector and hoses from purge control solenoid valve.
- 3) Remove the bolt which installs the purge control solenoid valve onto intake manifold.

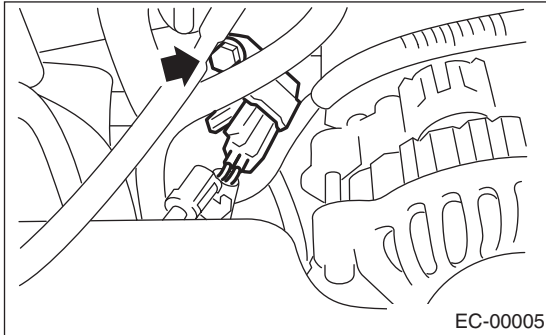

B: INSTALLATION

Install in the reverse order of removal.

Tightening torque:

16 N·m (1.6 kgf·m, 11.6 ft·lb)

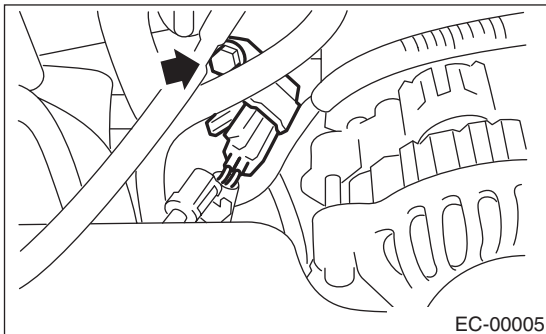

NOTE:

Connect the evaporation hoses as shown in the figure.

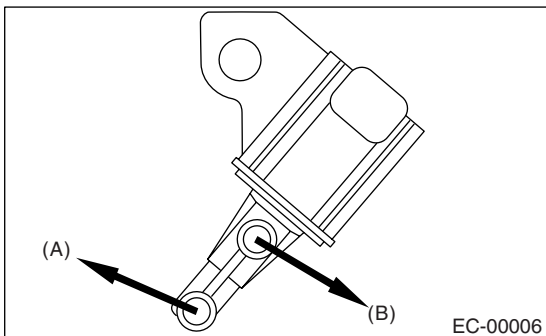

- (A) To purge valve
- (B) To intake manifold

C: INSPECTION

Make sure the hoses are not cracked or loose.

Fuel Level Sensor

EMISSION CONTROL (AUX. EMISSION CONTROL DEVICES)

6. Fuel Level Sensor

A: REMOVAL

For work procedures, refer to FU(STI) section.
<Ref. to FU(STI)-54, REMOVAL, Fuel Level Sensor.>

B: INSTALLATION

For work procedures, refer to FU(STI) section.
<Ref. to FU(STI)-54, INSTALLATION, Fuel Level Sensor.>

Fuel Temperature Sensor

EMISSION CONTROL (AUX. EMISSION CONTROL DEVICES)

7. Fuel Temperature Sensor

A: REMOVAL

Fuel temperature sensor and fuel level sensor are integrated into one unit; therefore, the removal procedure is the same as that for fuel level sensor. <Ref. to FU(STI)-54, REMOVAL, Fuel Level Sensor.>

B: INSTALLATION

Fuel temperature sensor and fuel level sensor are integrated into one unit; therefore, the installation procedure is the same as that for fuel level sensor. <Ref. to FU(STI)-54, INSTALLATION, Fuel Level Sensor.>

Fuel Sub Level Sensor

EMISSION CONTROL (AUX. EMISSION CONTROL DEVICES)

8. Fuel Sub Level Sensor

A: REMOVAL

For removal procedures, refer to FU(STI) section.
<Ref. to FU(STI)-55, REMOVAL, Fuel Sub Level Sensor.>

B: INSTALLATION

For installation procedures, refer to FU(STI) section.
<Ref. to FU(STI)-56, INSTALLATION, Fuel Sub Level Sensor.>

Fuel Tank Pressure Sensor

EMISSION CONTROL (AUX. EMISSION CONTROL DEVICES)

9. Fuel Tank Pressure Sensor

A: REMOVAL

WARNING:

- Place “NO FIRE” signs near the working area.
- Be careful not to spill fuel on the floor.

- 1) Remove the fuel tank. <Ref. to FU(STI)-45, REMOVAL, Fuel Tank.>
- 2) Remove the protector cover.

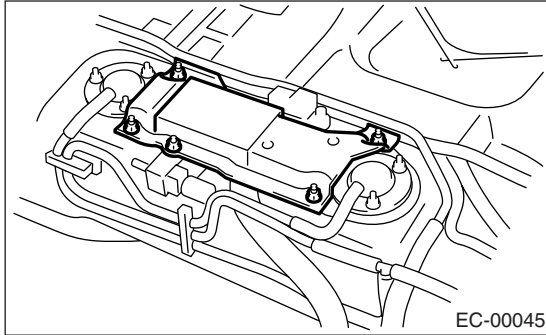

- 3) Disconnect the connector from fuel tank pressure sensor.
- 4) Release the clips which hold fuel pipes onto fuel tank.

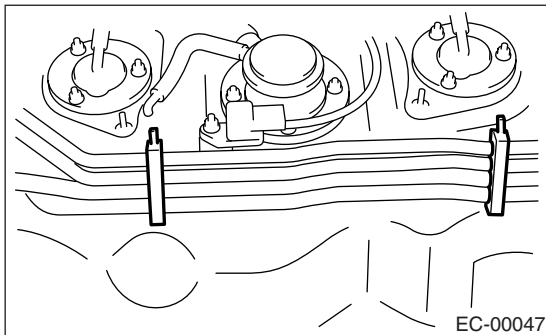

- 5) Remove the bolt and nut which hold the fuel tank pressure sensor onto the bracket.

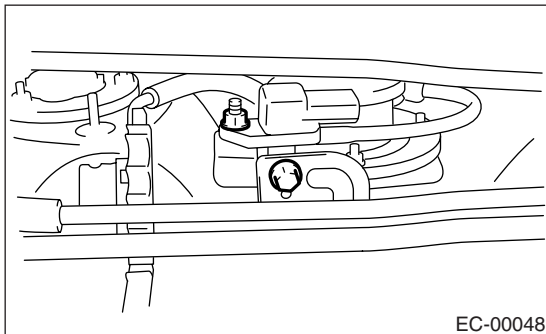

- 6) Disconnect the pressure hose from fuel tank pressure sensor.

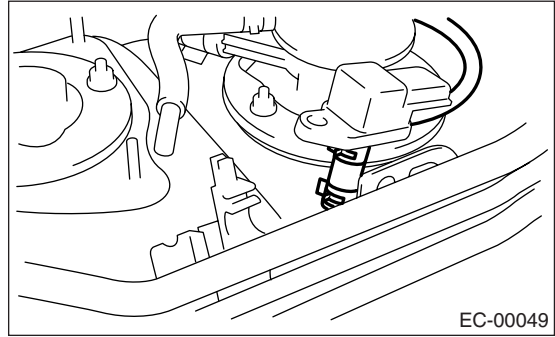

B: INSTALLATION

Install in the reverse order of removal.

Tightening torque:

7.4 N·m (0.75 kgf-m, 5.4 ft-lb)

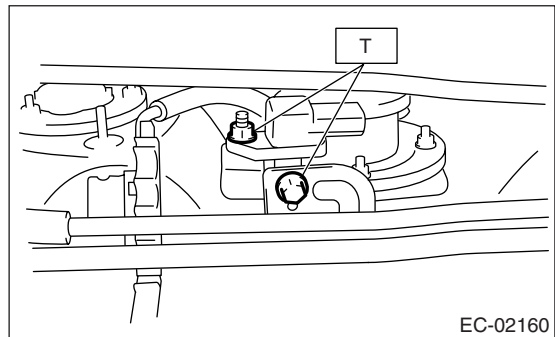

Tightening torque:

T1: 7.4 N·m (0.75 kgf-m, 5.4 ft-lb)

T2: 4.4 N·m (0.45 kgf-m, 3.3 ft-lb)

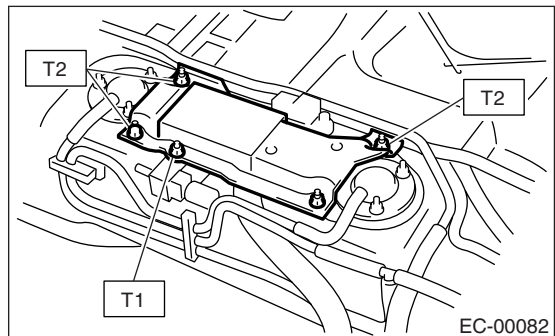

C: INSPECTION

Make sure the hoses are not cracked or loose.

10. Fuel Tank Sensor Control Valve

A: REMOVAL

WARNING:

- Place “NO FIRE” signs near the working area.
- Be careful not to spill fuel on the floor.

- 1) Remove the fuel tank. <Ref. to FU(STI)-45, REMOVAL, Fuel Tank.>
- 2) Remove the protector cover.

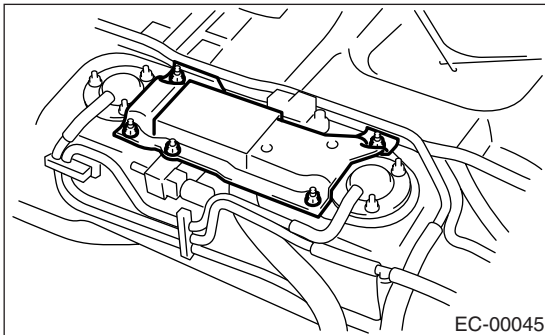

- 3) Disconnect the connector from fuel tank sensor control valve.
- 4) Disconnect hose and remove fuel tank sensor control valve.

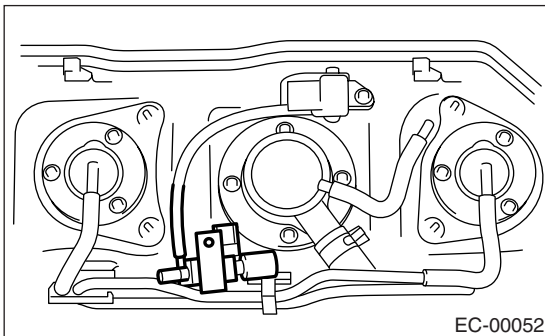

B: INSTALLATION

Install in the reverse order of removal.

Tightening torque:

T1: 7.4 N·m (0.75 kgf-m, 5.4 ft-lb)

T2: 4.4 N·m (0.45 kgf-m, 3.3 ft-lb)

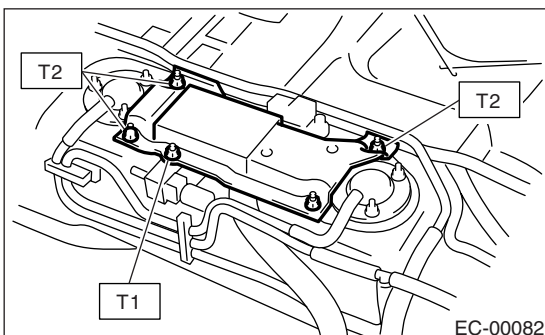

C: INSPECTION

Make sure the hoses are not cracked or loose.

Pressure Control Solenoid Valve

EMISSION CONTROL (AUX. EMISSION CONTROL DEVICES)

11. Pressure Control Solenoid Valve

A: REMOVAL

- 1) Set the vehicle on a lift.
- 2) Disconnect the ground cable from battery.
- 3) Lift up the vehicle.
- 4) Remove the canister. <Ref. to EC(STI)-5, REMOVAL, Canister.>
- 5) Remove the bolt which installs the pressure control solenoid valve holding bracket on body.

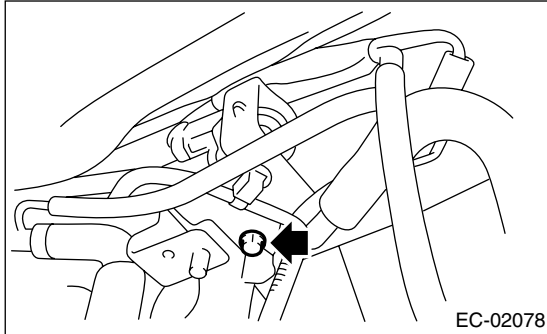

- 6) Remove the pressure control solenoid valve with bracket.
- 7) Disconnect the connector from pressure control solenoid valve.

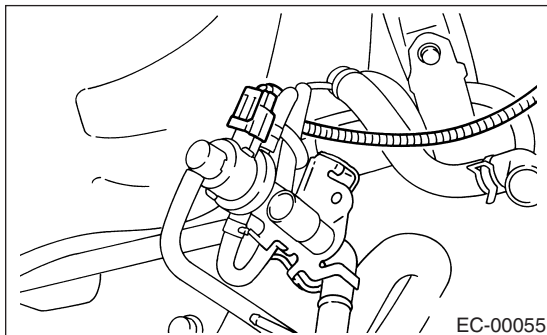

- 8) Disconnect the two evaporation hoses from pressure control solenoid valve.

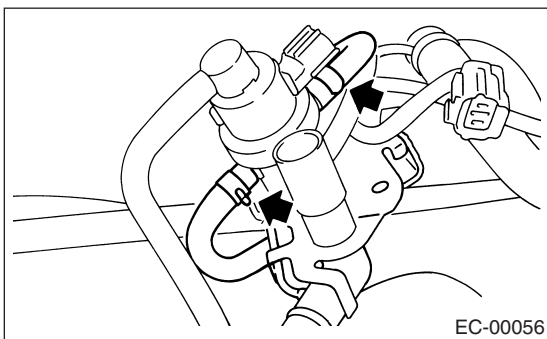

- 9) Remove the pressure control solenoid valve from bracket.

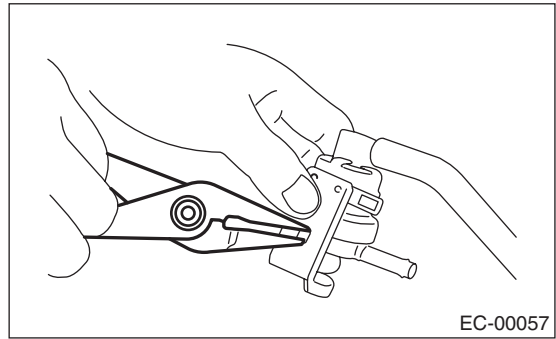

- 10) Disconnect the pressure control valve hose from pressure control solenoid valve.

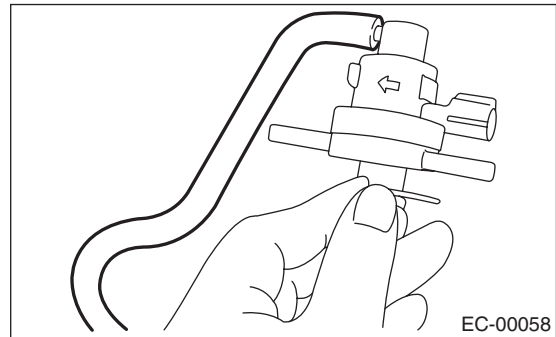

B: INSTALLATION

Install in the reverse order of removal.

Tightening torque:

25 N·m (2.6 kgf·m, 18.8 ft·lb)

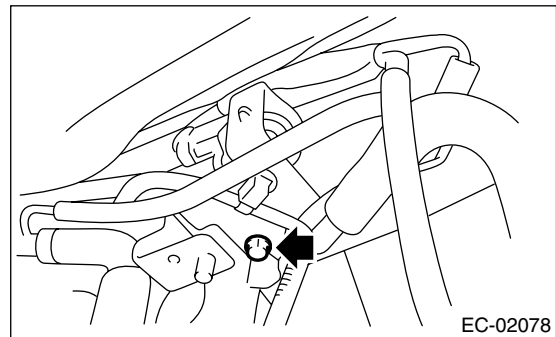

C: INSPECTION

Make sure the hoses are not cracked or loose.

Drain Filter

EMISSION CONTROL (AUX. EMISSION CONTROL DEVICES)

12.Drain Filter

A: SPECIFICATION

Drain filter is built in the canister, and it is a part which cannot be disassembled.

Vent Valve

EMISSION CONTROL (AUX. EMISSION CONTROL DEVICES)

13. Vent Valve

A: REMOVAL

WARNING:

- Place “NO FIRE” signs near the working area.
- Be careful not to spill fuel on the floor.

- 1) Remove the fuel tank. <Ref. to FU(STI)-45, REMOVAL, Fuel Tank.>
- 2) Remove the protector cover.

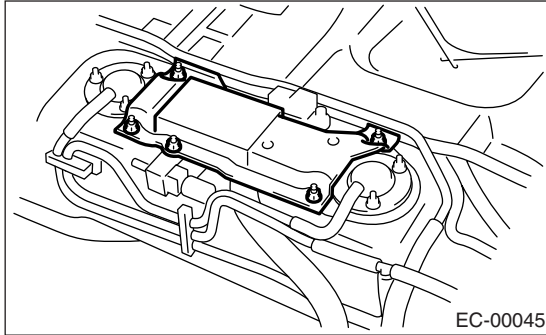

- 3) Remove the clips, and disconnect the hoses from vent valve.

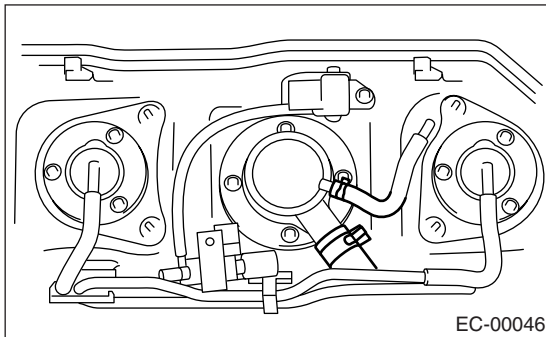

- 4) Remove the nuts and then remove the vent valve.

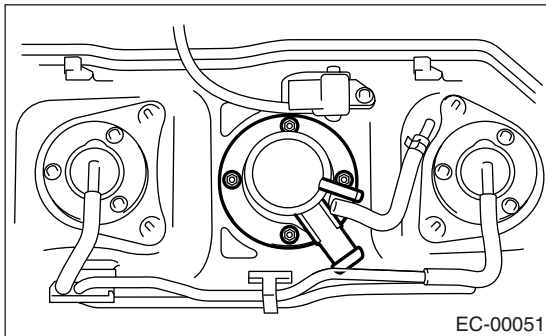

B: INSTALLATION

Install in the reverse order of removal.

NOTE:

Use a new gasket.

Tightening torque:

T: 4.4 N·m (0.45 kgf-m, 3.3 ft-lb)

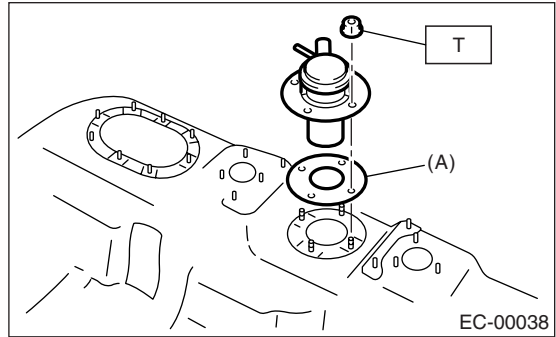

(A) Gasket

Tightening torque:

T1: 7.4 N·m (0.75 kgf-m, 5.4 ft-lb)

T2: 4.4 N·m (0.45 kgf-m, 3.3 ft-lb)

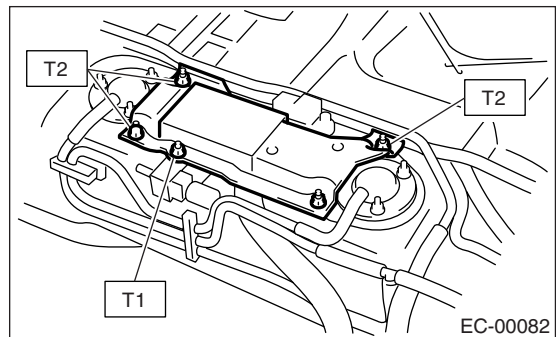

C: INSPECTION

Make sure the hoses are not cracked or loose.

Shut Valve

EMISSION CONTROL (AUX. EMISSION CONTROL DEVICES)

14. Shut Valve

A: REMOVAL

WARNING:

- Place “NO FIRE” signs near the working area.
- Be careful not to spill fuel on the floor.

- 1) Remove the fuel filler pipe. <Ref. to FU(STI)-48, REMOVAL, Fuel Filler Pipe.>
- 2) Disconnect the evaporation hoses from shut valve.

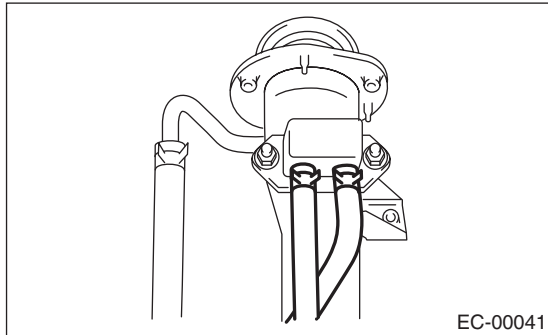

- 3) Remove the shut valve from fuel filler pipe.

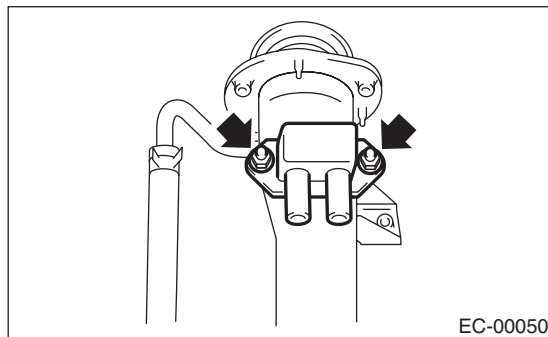

B: INSTALLATION

Install in the reverse order of removal.

Tightening torque:

4.5 N·m (0.46 kgf-m, 3.3 ft-lb)

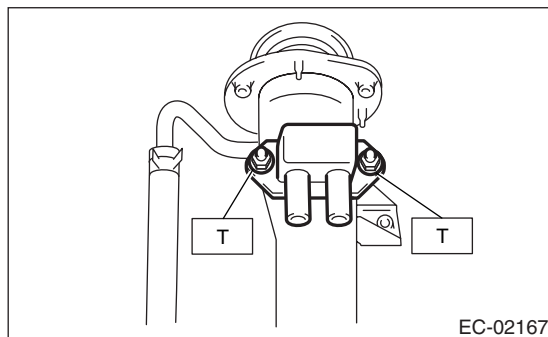

C: INSPECTION

Make sure the hoses are not cracked or loose.

Drain Valve

EMISSION CONTROL (AUX. EMISSION CONTROL DEVICES)

15. Drain Valve

A: REMOVAL

- 1) Set the vehicle on the lift.
- 2) Disconnect the ground cable from battery.
- 3) Lift up the vehicle.
- 4) Remove the canister. <Ref. to EC(STI)-5, REMOVAL, Canister.>
- 5) Remove clip (A), and then remove drain valve (B) from canister.
- 6) Remove the filter from drain valve (B).

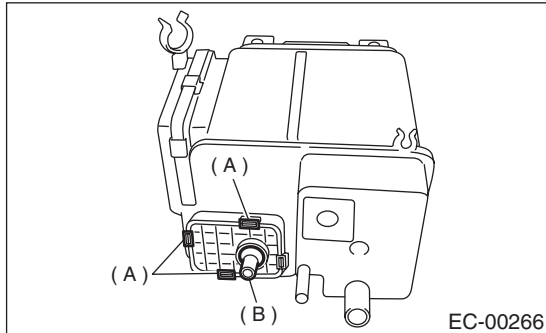

B: INSTALLATION

Install in the reverse order of removal.

CAUTION:

- Assemble the drain valve filter without any clearance.
- Make sure the packing in the groove before assembling drain valve to canister.
- Replace the clip with new one.

C: INSPECTION

- 1) Make sure that all hoses are installed securely.
- 2) Make sure that hoses are not cracked or loose.

16.PCV Hose Assembly

A: REMOVAL

CAUTION:

Removal is not allowed except for the damage of PCV hose, diagnosis connector and PCV valve.

1) Remove the intake manifold.

<Ref. to FU(STI)-13, REMOVAL, Intake Manifold.>

2) Clip the protrusion of clamp after aligning the concave portion of ST with protrusion of clamp, and then unlock the lock.

3) Remove the PCV hose assembly.

ST 18353AA000 CLAMP PLIERS

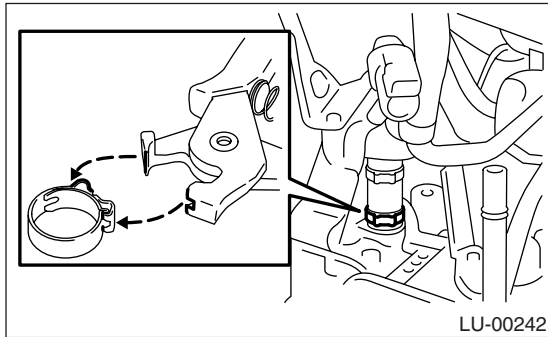

B: INSTALLATION

NOTE:

Replace the clamp with a new one.

1) Install the PCV hose assembly, and then lock the clamp with protrusion of clamp clipped by pliers.

ST 18353AA000 CLAMP PLIERS

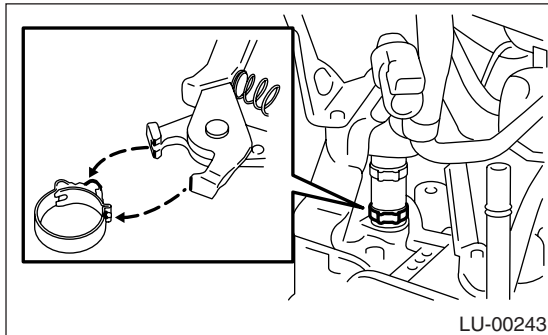

2) Install the intake manifold.

<Ref. to FU(STI)-16, INSTALLATION, Intake Manifold.>

PCV Hose Assembly

EMISSION CONTROL (AUX. EMISSION CONTROL DEVICES)
