

**SEAT**

# FRONT SEAT

SEAT

---

## 1. Front Seat

### A: ADJUSTMENT

Adjustment ranges are expanded to fit a wider variety of body types.

- The height of each headrest is adjustable to any of the 3 positions available.
- The uppermost position of the backrest is 11° rearwards from the perpendicular; the reclining angle is widened.
- A “towel bar” type seat slide lever is used for easier operation.
- The seat lifter mechanism has been changed from a system that lifts only the cushion to a system that lifts the entire seat.

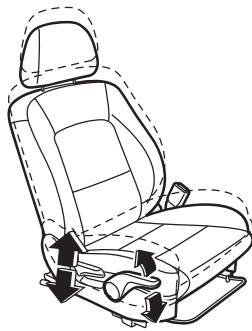

SE-00419



SE-00420

## B: HEIGHT ADJUSTER

The driver's seat is provided with a height adjuster. Both the seat cushion and backrest rise every time the lifter lever is pulled up; they lower every time the lever is pushed down.

The lever is enlarged for easier operation.

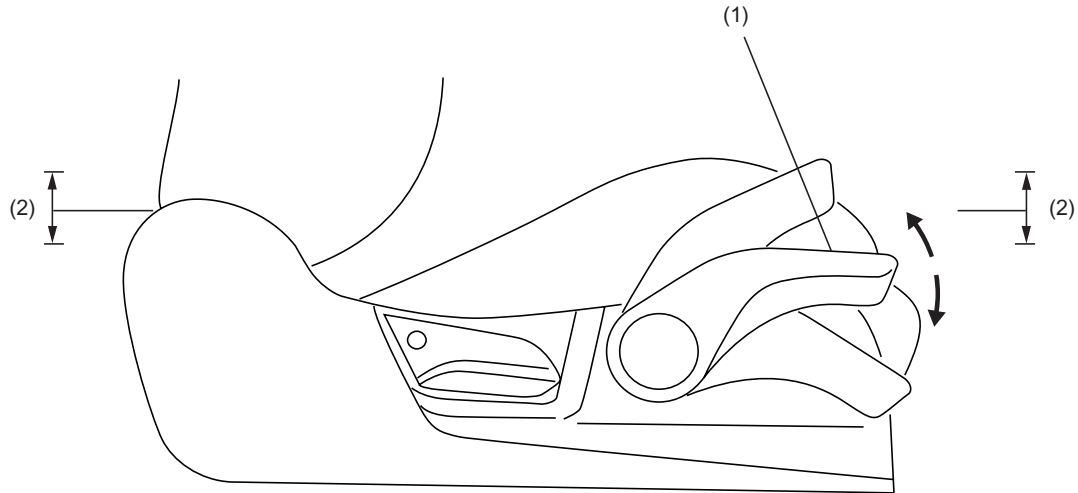

SE-00374

(1) Lifter lever

(2) Seat height adjustment range

## C: ACTIVE HEADREST

In case of rear-end collision, the headrest moves forward to immediately support the passenger's head to reduce the possibility of injury to the neck.

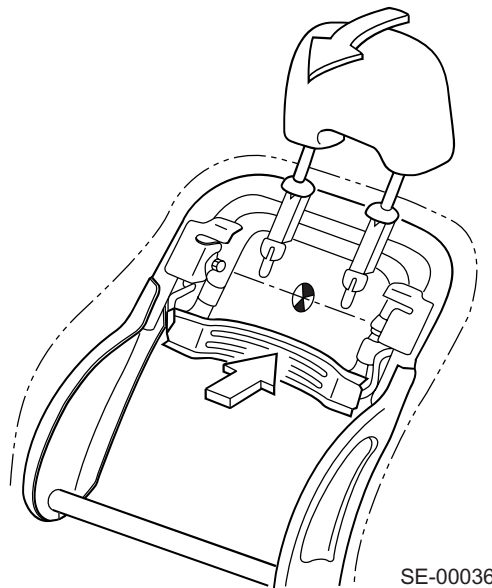

SE-00036

## FRONT SEAT

SEAT

---

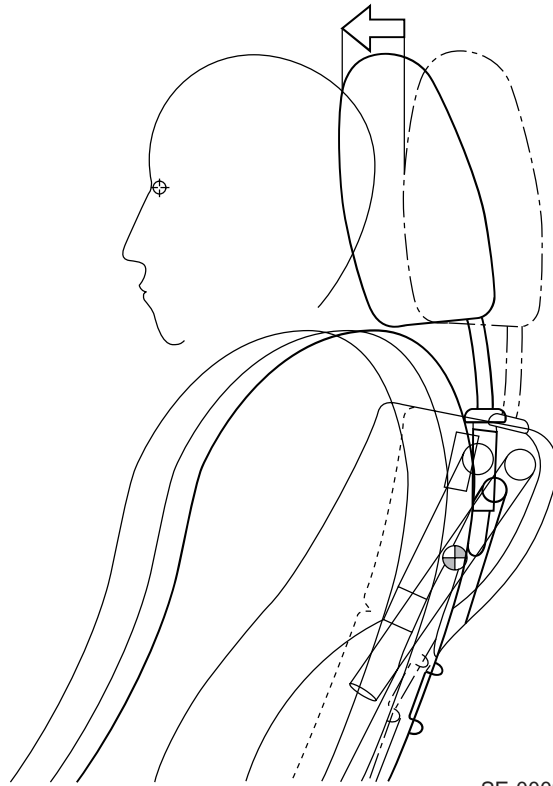

SE-00037

- 1) In case of rear-end collision, the passenger's body will move rearward by the impact.
- 2) When the body moves rearward, the thrust receiving plate inside the seat is pressed in.
- 3) When the thrust receiving plate is pressed in, the headrest moves forward due to a levering action.

## 2. Rear Seat

### A: OPERATION

#### 1. SEDAN MODELS

The backrest has an armrest. It is also featured with a “center through” function.

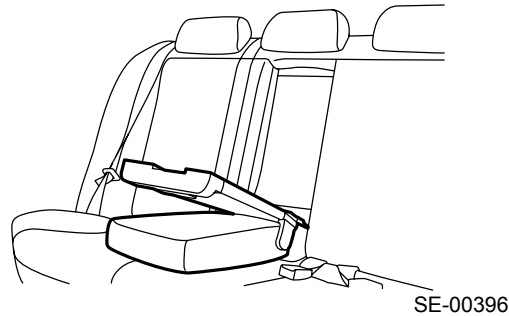

#### 2. WAGON MODELS

- Unlock the backrest by pushing the release button and then fold the backrest forwards.
- The backrest and shoulder portions are separated to improve support of the rear passenger's body. The backrest is also provided with a single-action folding feature, which contributes to form a flat luggage room by folding only the backrest forwards.

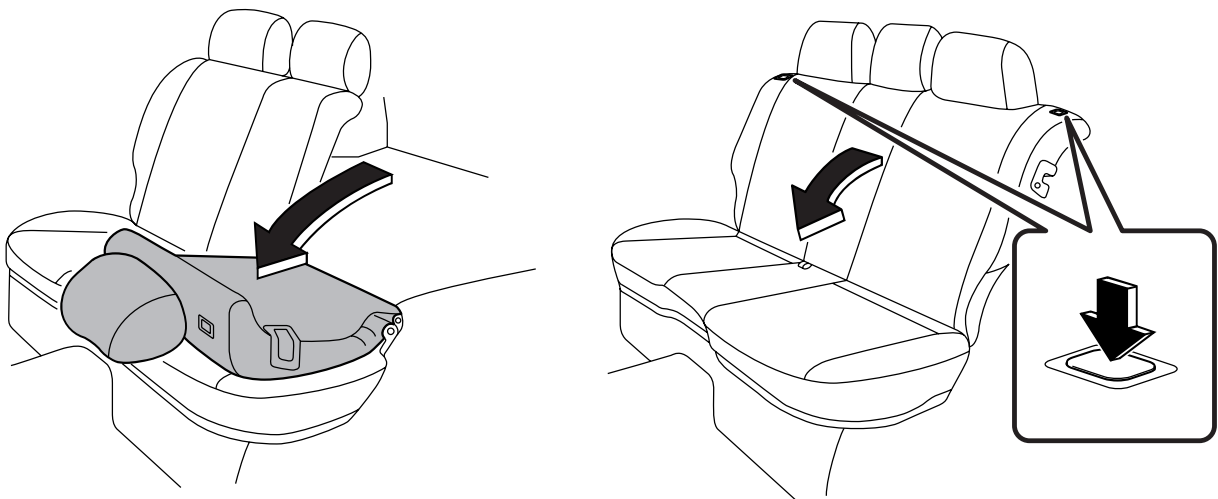

# OCCUPANT DETECTION SYSTEM (UNTIL '05MY)

SEAT

## 3. Occupant Detection System (Until '05MY)

### A: GENERAL

The passenger's seat is equipped with an occupant detection system, which consists of an occupant detection control module and four loadcell sensors, etc.

The occupant detection system sends signals to control the deployment of the passenger's seat air-bag when a child or small person is sitting in the passenger's seat.

### B: SYSTEM CONFIGURATION

The components of the occupant detection system are integrated as a seat cushion frame assembly; the assembly cannot be disassembled and the components cannot be replaced separately.

#### 1. OCCUPANT DETECTION CONTROL MODULE

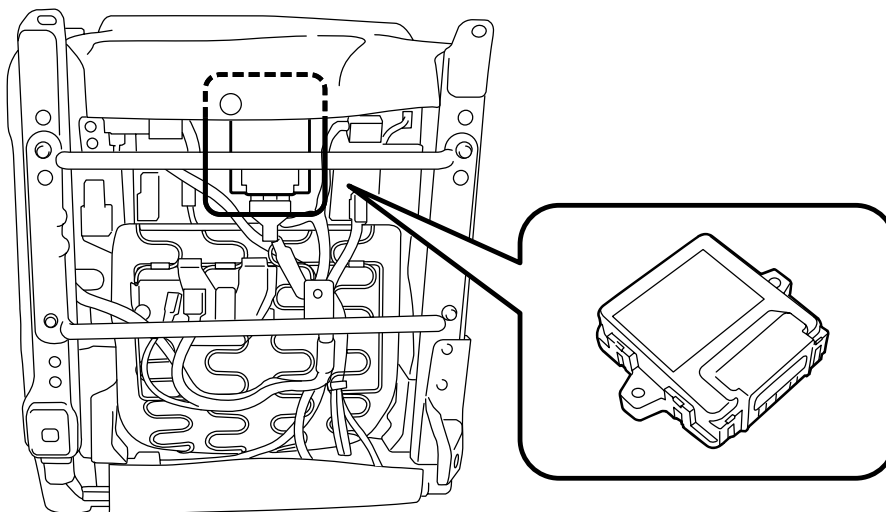

SE-00475

The occupant detection control module is installed under the passenger's seat and detects the presence/absence and physique of the person sitting in the passenger's seat based on signals sent from the loadcell sensors to send signals to the airbag control module.

If there is any abnormality in the occupant detection control module, the airbag warning light in the combination meter illuminates to warn the driver of system abnormality. Diagnostic trouble codes can be read by using a Subaru select monitor.

## 2. LOADCELL SENSOR

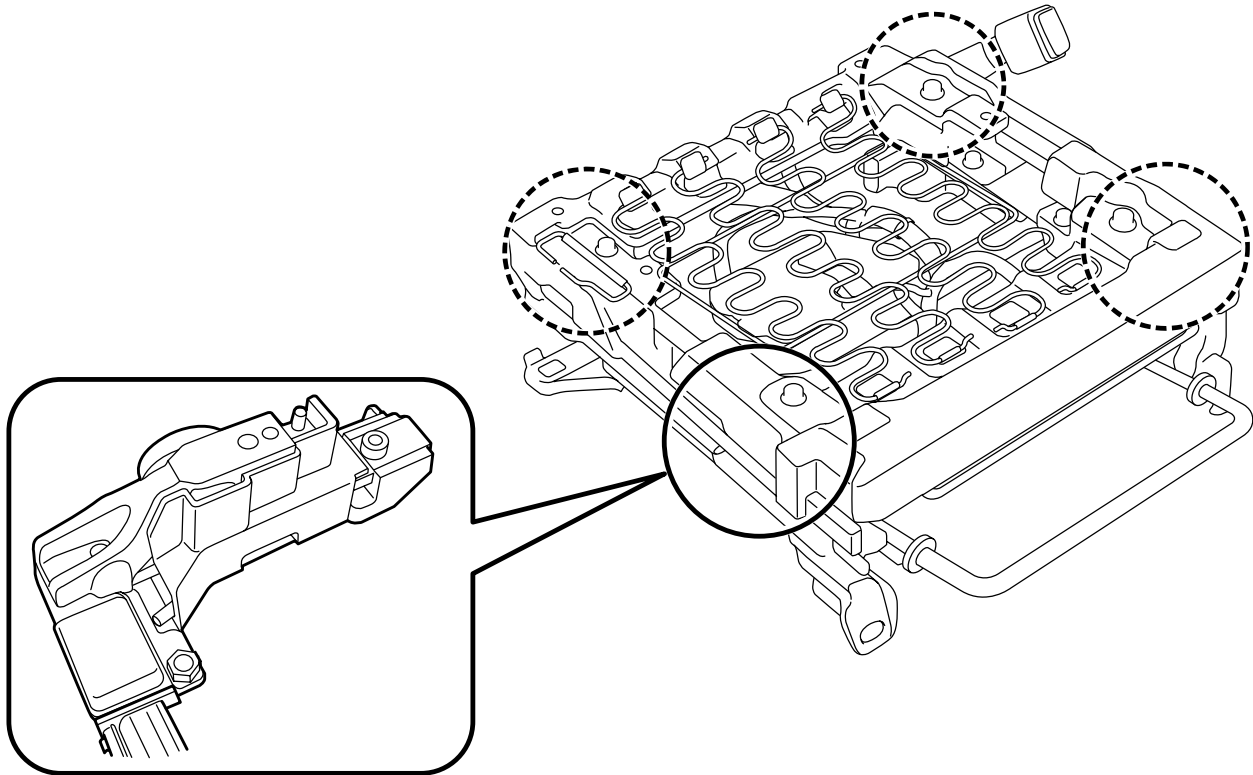

SE-00476

Four loadcell sensors are installed on the passenger's seat and each sensor measures the load to send signals to the load occupant detection control module.

# OCCUPANT DETECTION SYSTEM (UNTIL '05MY)

SEAT

---

## 3. PASSENGER'S SEAT AIRBAG INDICATOR

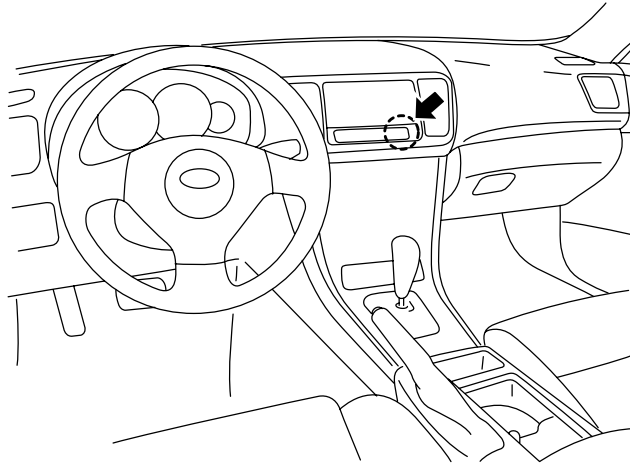

SE-00477

The passenger's seat airbag indicator light is built in the center part of the instrument panel. The light indicates the result judged by the occupant detection control module.

Depending on the occupant detection control module's decision, the passenger's seat airbag may not deploy even in case of a frontal collision, however, the driver's seat airbag will deploy and the driver/passenger seat belt pretensioners are controlled to activate. Also, the driver/passenger seat side airbags and the left/right curtain airbags are controlled to activate.

For initial check of the occupant detection system, both the ON (will deploy) and OFF (will not deploy) indicators will illuminate for about 6 seconds after the ignition switch is turned ON, and then turns OFF simultaneously for 2 seconds.



## 4. Occupant Detection System (From '06MY)

### A: GENERAL

In '06MY, the occupant detection system was changed. The loadcell sensor that is located between the seat cushion and the seat frame consists of the bladder (bag) containing silicon gel and the pressure sensor connected with a hose. When the passenger sits in the passenger's seat, the silicon gel contained in the bladder is pushed. The loadcell sensor measures this pressure, and then it sends the signal to the occupant detection control module. The occupant detection control module detects the physique of the person sitting in the passenger's seat based on the signals, and then it sends the control signal to the airbag control module.

The belt tension sensor was also added to the outer seat belt. The belt tension sensor detects the status that seat belt is continuously tensioning (when the child seat is attached to the passenger's seat, etc.), and then it sends the signal to the occupant detection control module.

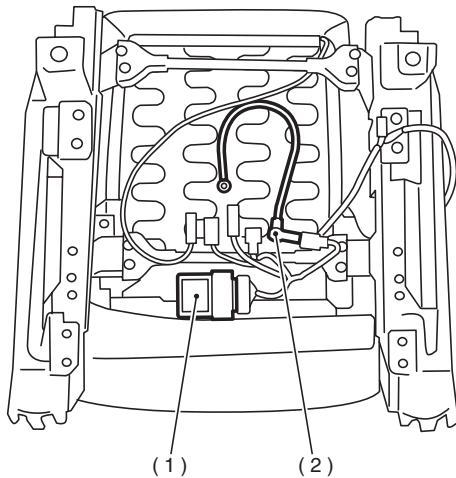

SE-00666

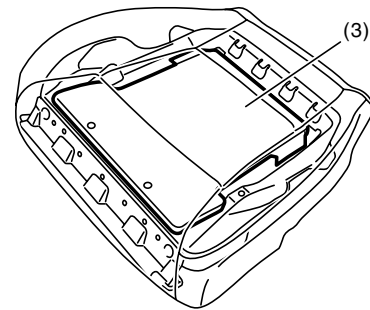

SE-00667

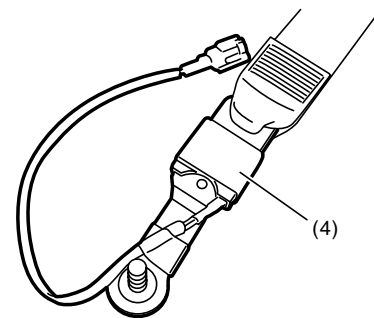

SE-00668

- (1) Occupant detection control module
- (2) Loadcell sensor
- (3) Bladder (with silicon gel)
- (4) Belt tension sensor