

SEAT BELT SYSTEM

SEAT BELT

SEAT BELT SYSTEM

1. Seat Belt

A: ADJUSTABLE SHOULDER BELT ANCHOR

1. FRONT

Each front seat belt system has an adjustable shoulder belt anchor, which allows the occupant to select the most appropriate anchor height from among the five positions in a 90 mm (3.54 in) range.

The sash guide is put inside the pillar trim to improve the appearance.

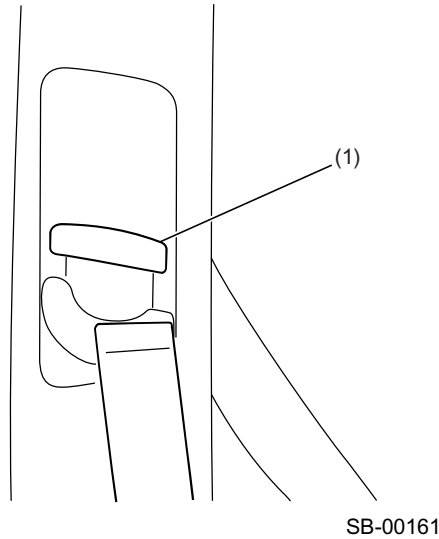

(1) Height adjuster button

B: REAR SEAT BELT

1. SEDAN MODELS

- A three-point type seat belt is provided on all seats.
- The retractor for the seat belt is installed on the rear shelf behind the seating position.

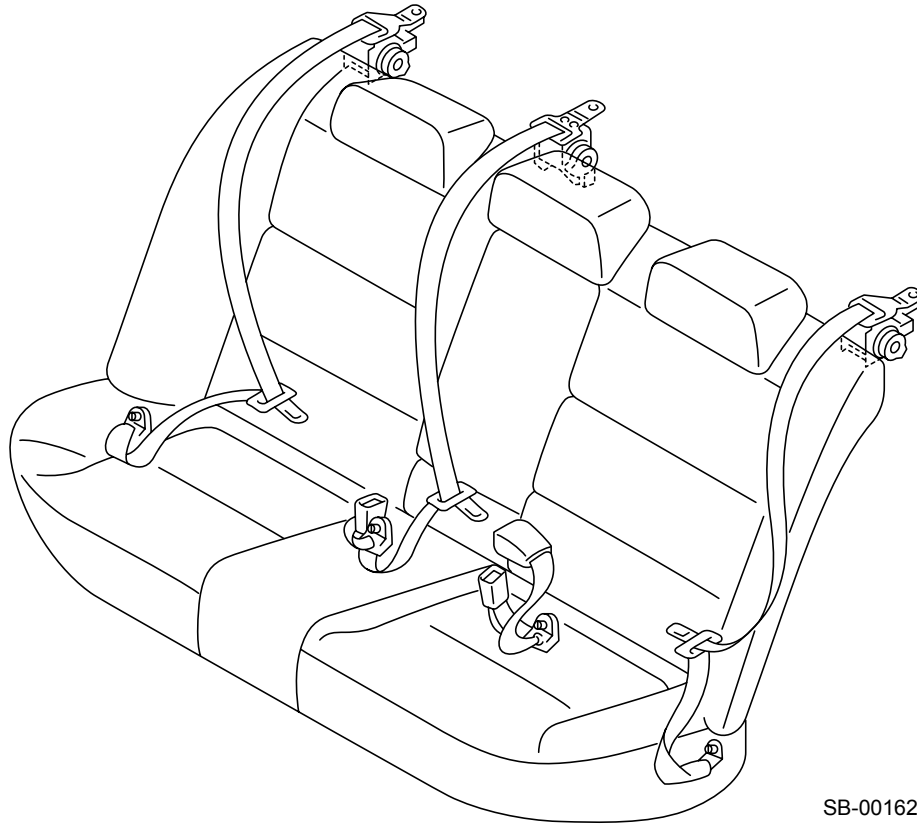

SB-00162

SEAT BELT

SEAT BELT SYSTEM

2. WAGON MODELS

- A three-point type seat belt is provided on all seats.
- The seat belt for the center seat is installed to the rear right corner of the roof and can be detached at its connector to save the luggage space.

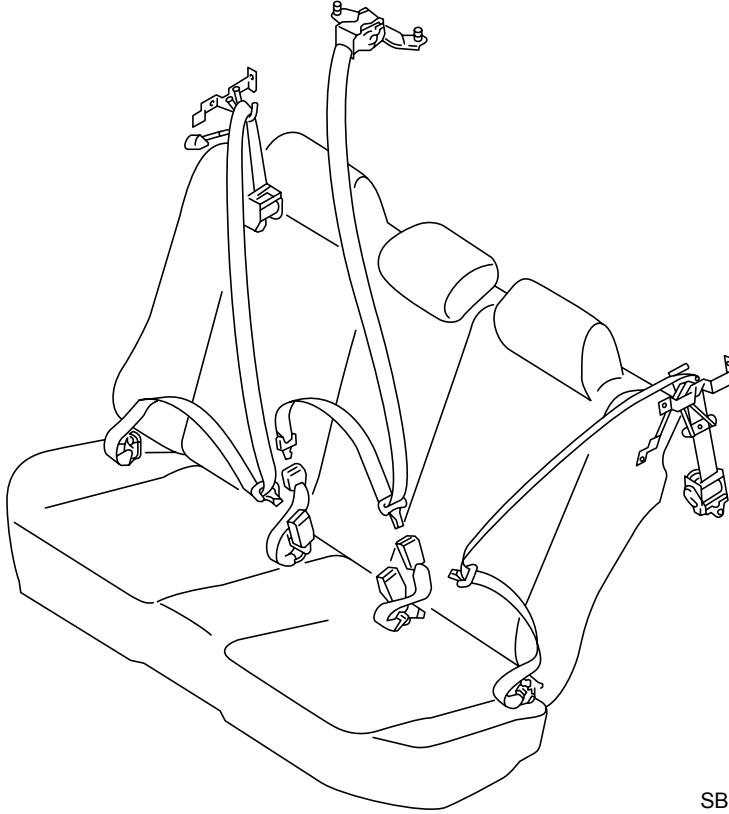

SB-00163

- Seat belts for the outer seats are provided with a new belt folding bracket at inside of the rear quarter trim to improve the appearance.

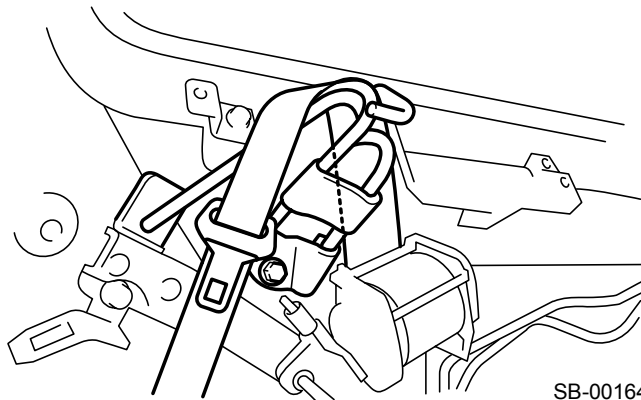

SB-00164

C: AUTOMATIC RETRACTOR (CHILD RESTRAINT SYSTEM FIXING FEATURE)

When any of the rear seat belts is drawn out completely, its retractor is placed in the automatic locking mode, which is used when installing a child restraint system. In this mode, the belt can be retracted but cannot be extended. When the belt is retracted to a certain length, this mode is cancelled and normal operation is restored.

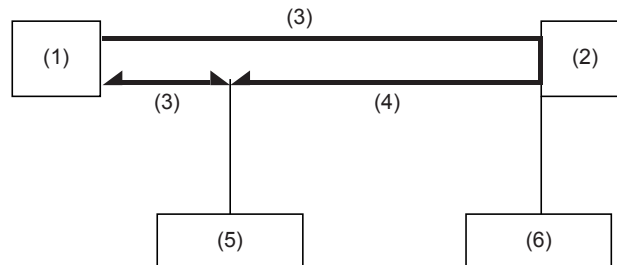

SB-00169

- (1) Fully retracted
- (2) Fully extended
- (3) Normal mode (belt can be retracted and pulled out)
- (4) Automatic lock mode (belt can be retracted but cannot be pulled out)
- (5) Automatic locking mode to normal mode changeover
- (6) Normal locking mode to automatic locking mode changeover

SEAT BELT LIGHT

SEAT BELT SYSTEM

2. Seat Belt Light

A: SEAT BELT WARNING LIGHT

A seat belt warning light is provided for the front seats to warn the passengers to fasten the seat belt.

The driver's seat warning light is located in the combination meter, and the front passenger's seat belt warning light and rear seat belt fastening indicator are located at the center of the map light lens.

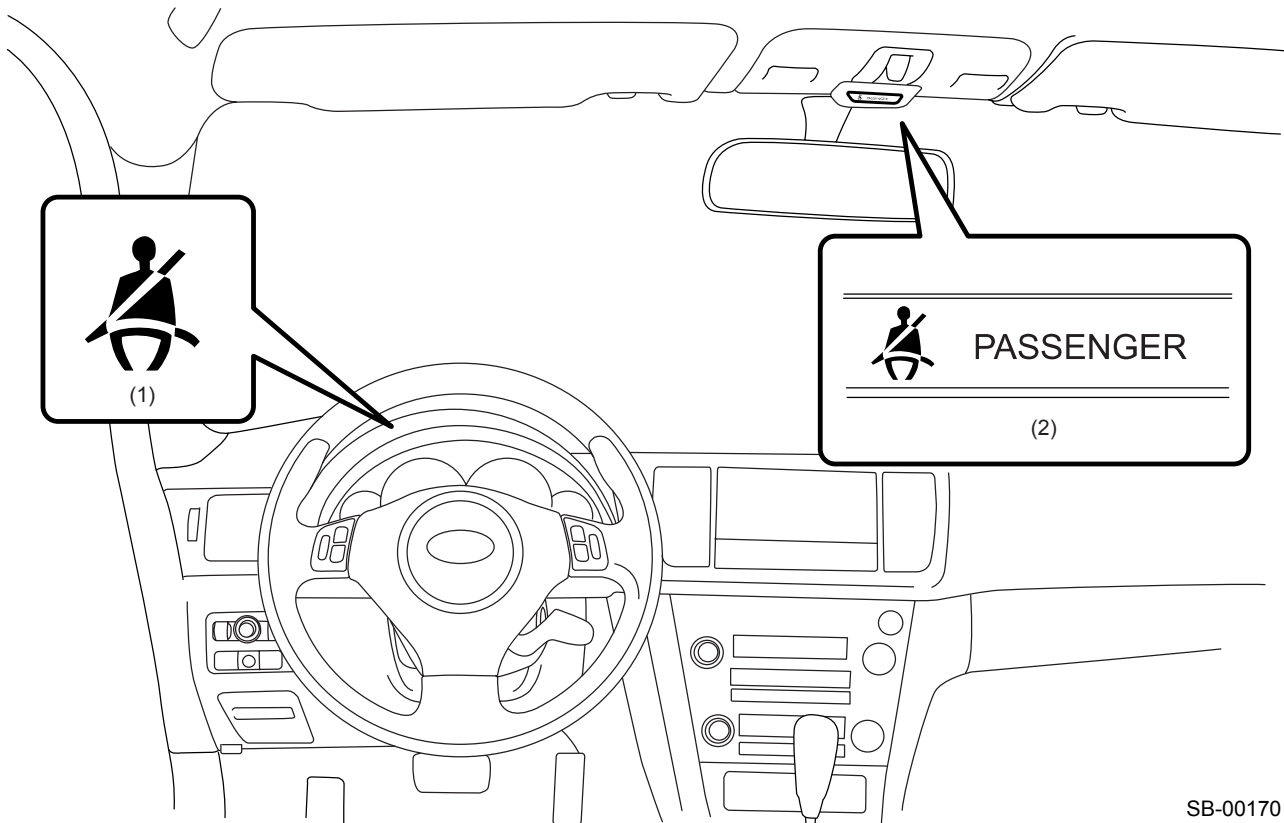

SB-00170

(1) Driver's seat warning light

(2) Passenger's seat warning light

B: SEAT BELT ALARM SYSTEM

1. GENERAL

When the ignition switch is turned ON, the seat belt warning light in the combination meter illuminates for 6 seconds and the warning buzzer sounds to warn the driver to fasten the seat belt. The seat belt warning light turns off and the buzzer ceases when the seat belt tongue plate is inserted into the seat belt buckle.

If the driver starts the vehicle without fastening the seat belt, the warning light illuminates or blinks and the buzzer sounds to warn the driver to fasten the seat belt. The seat belt warning light turns off and the buzzer ceases when the seat belt tongue plate is inserted into the seat belt buckle.

The passenger's seat side is also provided with a seatbelt alarm system, which turns ON the passenger's seat belt warning light when it detects a passenger through the passenger sensor (load cell sensor). If the driver starts the vehicle without fastening the seat belt, the seat belt warning light illuminates or blinks and the buzzer sounds to warn the passenger to fasten the seat belt.

2. SYSTEM STATUS TRANSITION

Alarms that are given with the seat belt warning light and buzzer vary in accordance with the vehicle speed and seat belt fastened/unfastened state. (The alarm system can warn the driver and the passenger individually, however, if both seat belts are not fastened, the buzzer will give priority to warn the driver.)

1) When the ignition switch is turned ON (with the seat belt not fastened), the seat belt warning light flashes for 6 seconds. If the seat belt is not fastened within this period, an alarm is given with a buzzer sound*.

*: The buzzer sounds only when the driver's seat belt is not fastened.

2) After 6 seconds since the ignition switch is turned ON, the seat belt warning light starts to illuminate or flash for every 15 seconds, and the buzzer will sound if the warning light is flashing.

3) If the seat belt is unfastened again when the vehicle speed is at or over 15 km/h (9 MPH), the seat belt warning light repeats illuminating or flashing, and the buzzer will sound if the warning light is flashing.

3. CUTOFF FUNCTION

The warning given after 6 seconds since the ignition switch is turned ON, and the warning function that activates when the seat belt is unfastened while driving can be optionally cut off. The cutoff function is common for both the driver's seat and passenger's seat, and can be set with the driver's seat buckle switch.

Temporary (TEMP) cutoff

1) How to cut: Repeat fastening and unfastening the driver's seat belt for 3 times within 6 seconds after turning the ignition switch ON. (The setting is changed for both the driver's seat and passenger's seat.)

2) Setting lasts: While the ignition switch is turned ON until it is turned OFF. (The cutoff function is canceled when the ignition switch is once turned OFF.)

Permanent cutoff

1) How to cut: Repeat fastening and unfastening the driver's seat belt for 20 times within 30 seconds after turning the ignition switch ON. Enabling and disabling cutting is done with the same operation. (The setting is changed for both the driver's seat and passenger's seat.)

SEAT BELT LIGHT

SEAT BELT SYSTEM

2) Setting lasts: Until the microprocessor is reset*.

The cutoff function is reset when the battery is removed (battery positive terminal disconnected) or when the body integrated unit is removed. The cutting function may also be reset when the engine is cranked with low battery voltage.