

COOLING (H₄SO)

1. General

- The engine cooling system consists of a down-flow radiator featuring high heat-dissipation performance, an electric-motor-driven fan, a water pump, a thermostat, and an engine coolant temperature sensor.
- The reservoir tank is made of translucent resin and enables easy confirmation of the coolant level. Also, coolant should be added to the reservoir tank when replenishment is necessary.
- The ECM controls the operation of the radiator main fan and sub fan depending on the signals from the engine coolant temperature sensor, vehicle speed sensor and A/C switch.

2. Cooling Circuits

The cooling system operates in three different phases depending on the temperature of the engine coolant.

- 1st phase (thermostat closed)

When the engine coolant temperature is lower than the preset value, the thermostat remains closed. The coolant flows through the heater circuit. This permits the engine to warm up quickly.

- 2nd phase (thermostat open)

When the engine coolant temperature reaches the preset value, the thermostat opens. The coolant flows through the radiator where it is cooled.

- 3rd phase (thermostat open and radiator fan operating)

When the engine coolant temperature becomes higher than the preset value, the ECM receives a signal from the engine coolant temperature sensor and causes the radiator fan(s) to operate.

NOTE:

Refer to the Service Manual for preset engine coolant temperature values for each stage.

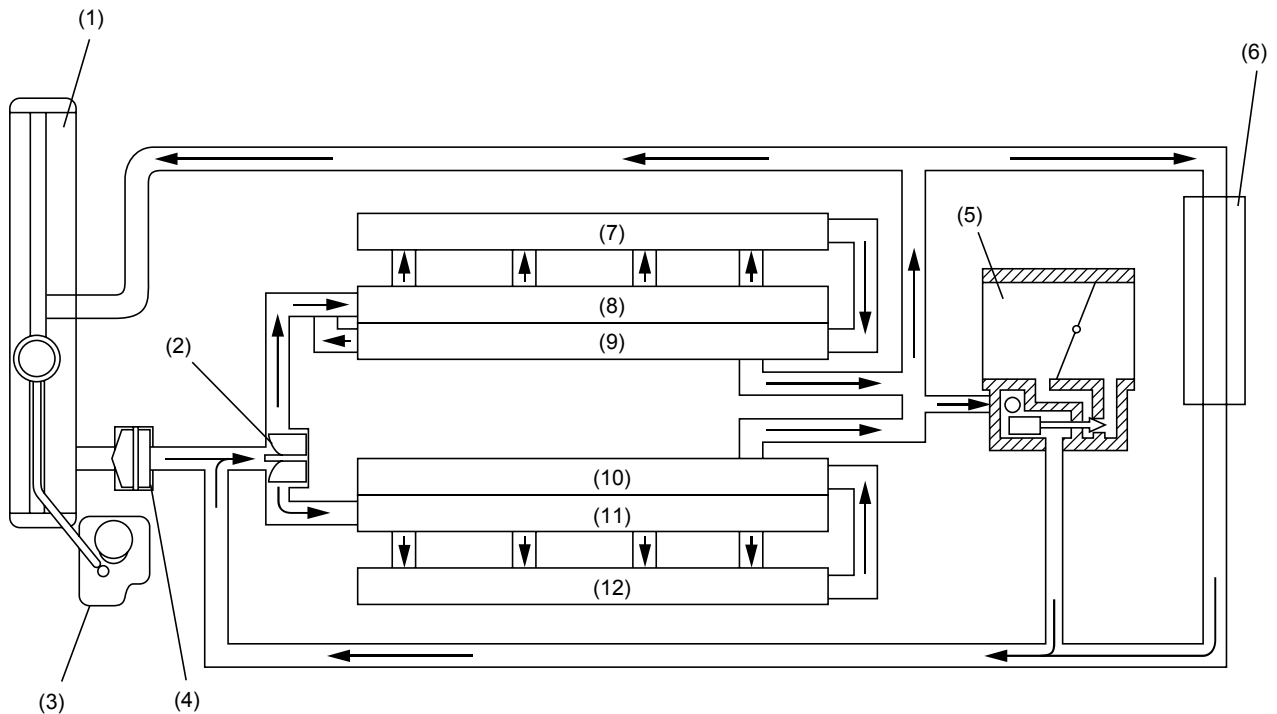

CO-02110

- | | |
|-----------------------------------|-------------------------|
| (1) Radiator | (7) Cylinder head RH |
| (2) Water pump | (8) Cylinder jacket RH |
| (3) Engine coolant reservoir tank | (9) Cylinder block RH |
| (4) Thermostat | (10) Cylinder block LH |
| (5) Throttle body | (11) Cylinder jacket LH |
| (6) Heater core | (12) Cylinder head LH |

WATER PUMP

COOLING

3. Water Pump

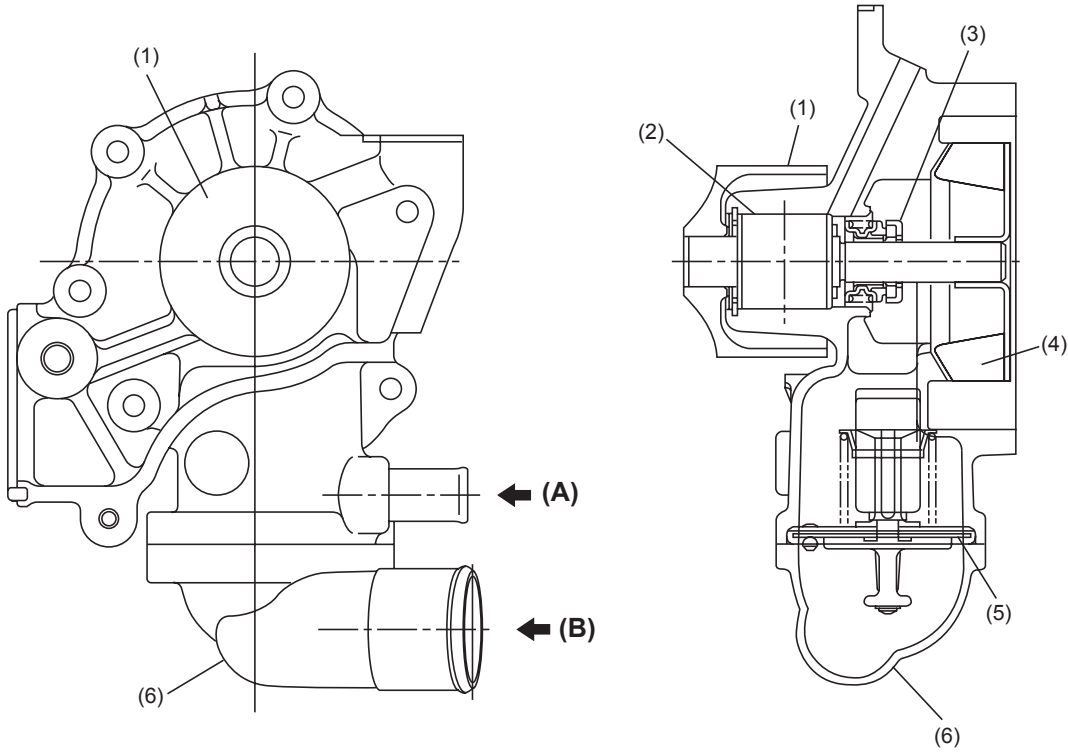

CO-02119

- (A) From heater circuit
- (B) From radiator

- (1) Pulley
- (2) Ball bearing
- (3) Mechanical seal
- (4) Impeller
- (5) Thermostat
- (6) Thermostat cover

4. Mechanical Seal

The mechanical seal has its seat tightly fitted on the water pump shaft. Since it is a hermetic seal forming an integral part of the water pump, the water pump cannot be disassembled.

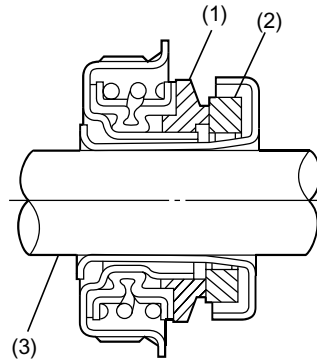

CO-00058

- (1) Carbon seal
- (2) Ceramics seat
- (3) Water pump shaft

THERMOSTAT

COOLING

5. Thermostat

The thermostat has a totally enclosed wax pellet, which expands as the coolant temperature increases. It opens and closes accurately at the preset temperatures and features high durability.

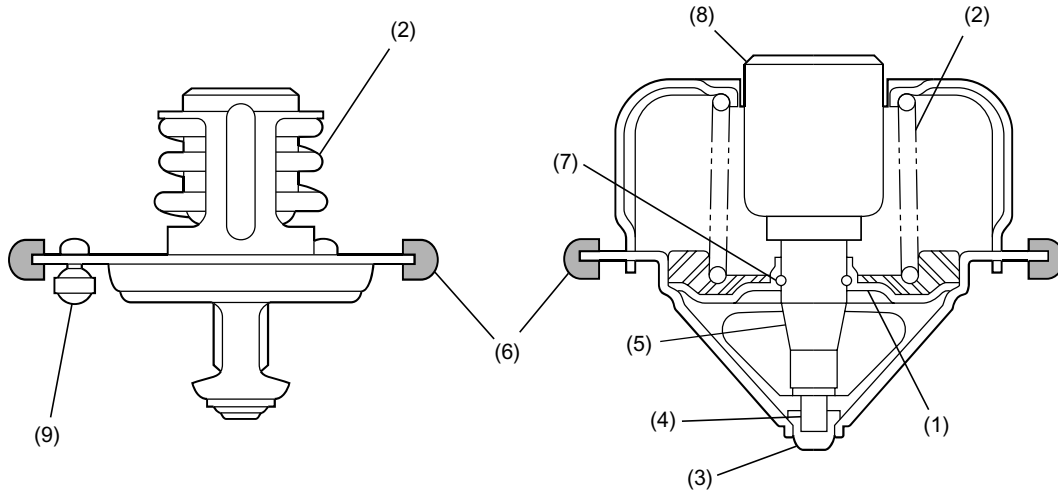

CO-00059

- | | | |
|-------------|--------------------|------------------|
| (1) Valve | (4) Piston | (7) Stop ring |
| (2) Spring | (5) Guide | (8) Wax element |
| (3) Stopper | (6) Rubber packing | (9) Jiggle valve |

CO(H4SO)-6

6. Radiator Fan

A: DESCRIPTION

Each radiator fan is made of plastic. It is driven by an electric motor, which is retained on a shroud.

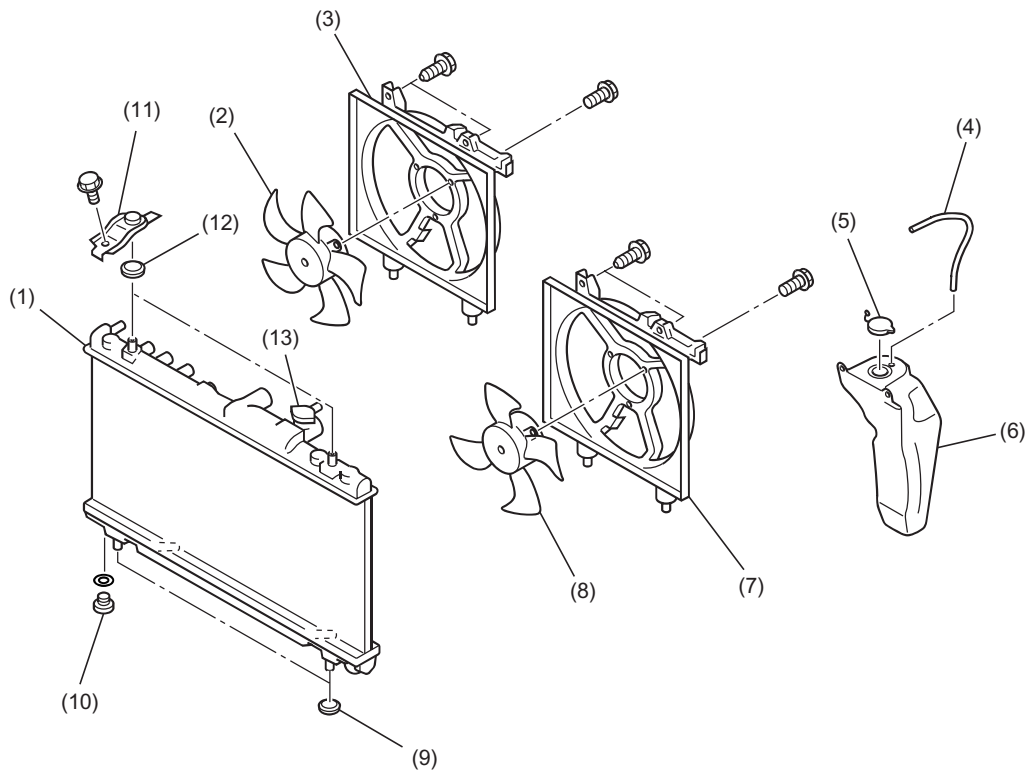

CO-00282

- | | |
|---|---|
| (1) Radiator | (8) Radiator main fan and main fan motor assembly |
| (2) Radiator sub fan and sub fan motor assembly | (9) Lower cushion |
| (3) Radiator sub fan shroud (models with A/C) | (10) Drain plug |
| (4) Overflow hose | (11) Upper bracket |
| (5) Reservoir tank cap | (12) Upper cushion |
| (6) Reservoir tank | (13) Radiator cap |
| (7) Radiator main fan shroud | |

RADIATOR FAN

COOLING

To reduce fan noise, the fan output is two-stepped and can be switched to Low or High according to the load on A/C, coolant temperature, and vehicle speed. This control is accomplished by a circuit as shown below; the output is changed by switching the connection of two motors between serial and parallel instead of using components such as resistors.

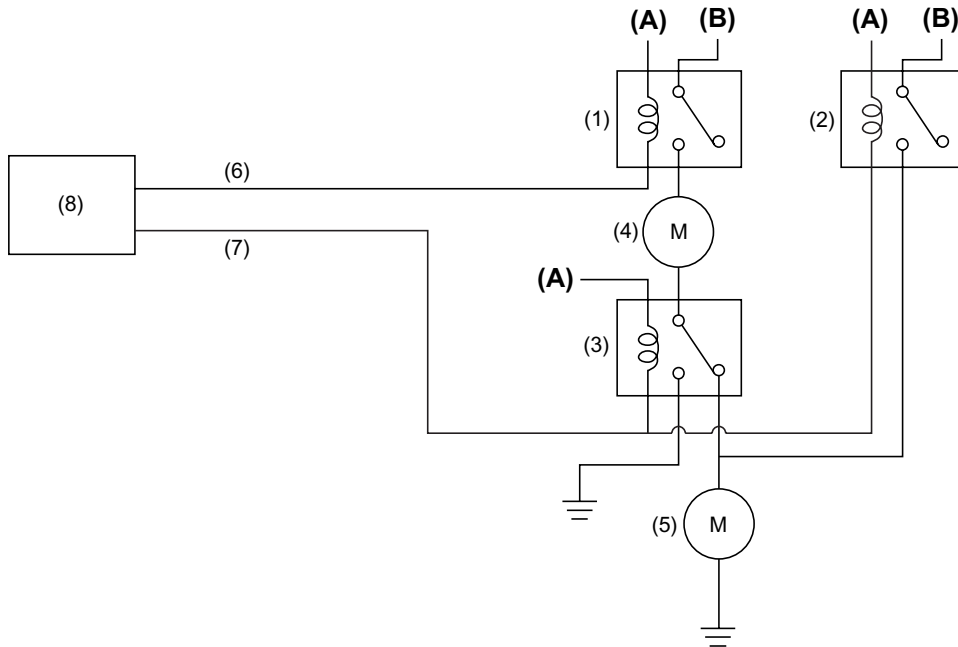

CO-00060

- | | |
|----------------------|--------------------------|
| (1) Sub fan relay | (6) Low speed signal |
| (2) Main fan relay 1 | (7) High speed signal |
| (3) Main fan relay 2 | (8) ECM |
| (4) Sub fan motor | (A) From ignition switch |
| (5) Main fan motor | (B) From battery |

RADIATOR FAN

COOLING

B: FUNCTION

On models equipped with an air conditioning system, the ECM receives signals from the engine coolant temperature sensor, vehicle speed sensor and A/C switch, and based on these signals, the ECU controls the fan speed to Hi or Low.

NOTE:

Refer to the Service Manual for operation of each model.

Operation examples:

Vehicle speed	A/C compressor load	Engine coolant temperature		
		Rising: below 95°C (203°F) Lowering: below 92°C (198°F)	Rising: between 96 and 99°C (205 and 210°F) Lowering: between 93 and 94°C (199 and 201°F)	Rising: over 100°C (212°F) Lowering: over 95°C (203°F)
		Operation of radiator fans	Operation of radiator fans	Operation of radiator fans
When accelerating: below 19 km/h (12 MPH) When decelerating: below 10 km/h (6 MPH)	OFF	OFF	Low-Speed	High-Speed
	Low	Low-Speed	Low-Speed	High-Speed
	High	High-Speed	High-Speed	High-Speed
When accelerating: between 20 and 69 km/h (12 and 43 MPH) When decelerating: between 11 and 64 km/h (7 and 40 MPH)	OFF	OFF	Low-Speed	High-Speed
	Low	High-Speed	High-Speed	High-Speed
	High	High-Speed	High-Speed	High-Speed
When accelerating: between 70 and 105 km/h (43 and 65 MPH) When decelerating: between 65 and 103 km/h (40 and 64 MPH)	OFF	OFF	Low-Speed	High-Speed
	Low	OFF	Low-Speed	High-Speed
	High	Low-Speed	High-Speed	High-Speed
When accelerating: over 106 km/h (66 MPH) When decelerating: over 104 km/h (64.6 MPH)	OFF	OFF	OFF	High-Speed
	Low	OFF	Low-Speed	High-Speed
	High	OFF	Low-Speed	High-Speed

RADIATOR CAP

COOLING

7. Radiator Cap

The radiator cap has a pressure valve and a vacuum valve. When the radiator inner pressure becomes higher than specified, the pressure valve opens to send coolant to the reservoir tank. Also, when the radiator inner pressure becomes lower than the atmospheric pressure during the cooling down phase, the vacuum valve opens to send back coolant from the reservoir tank to the radiator. These functions prevent damage to the radiator components.

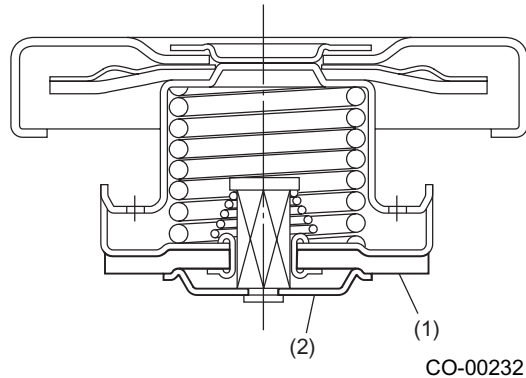

- (1) Pressure valve
- (2) Vacuum valve