

AUTOMATIC TRANSMISSION (5AT)

1. General

To improve the dynamic performance and fuel efficiency of the vehicle, a new 5-speed automatic transmission is developed. The features of this new automatic transmission are as follows:

A: NEW CONSTRUCTION

- The planetary gears layout has been changed from the conventional 2-planetary to a 3-planetary arrangement.
- The construction of the torque converter has been changed to achieve a higher efficiency.
- The layout of the oil pump has been changed to reduce friction.
- The drive pinion gear has been changed.
- Major components are made of aluminum.

B: CHANGES FOR BETTER DRIVING PERFORMANCE

1. IMPROVED SHIFTING PERFORMANCE

- By using a wide ranged and crossed ratio gears, a high driving power is ensured at a wide vehicle speed range, and the torque differential between before and after shifting is minimized.
- By using a system that controls the clutch pressure directly and electronically (direct hydraulic control), an accurate and highly responsive control is achieved.
- By using a one-way clutch, smooth shifting without torque interruption is realized.
- By using a new adaptive control, the shifting map is automatically switched and a more active shifting control is performed in the manual mode.
- The control enables manual shifting by operating the steering switch to UP or DOWN while driving in D range, and returns to normal automatic shifting when certain conditions are met.
- To reduce gear noise from the reduction driven gear and prevent the bending moment of the drive pinion shaft from affecting the engagement of reduction gears, the front and rear ends are supported with bearings.
- To reduce driving noise, the drive shafts and joints are integrated and the transmission side drive axle shaft is abolished.

C: MODIFICATION MADE FOR BETTER FUEL EFFICIENCY

1. OPTIMIZED GEAR RATIO

- The wider gear ratio range obtained by five speeds contribute to better dynamic performance, while improving fuel efficiency at constant speed cruising by enabling use of lower engine speeds.

2. IMPROVED EFFICIENCY

- The efficiency of the torque converter has been increased.
- Friction in the oil pump and gear train are reduced.
- Drive pinion gear teeth are changed to uniform height teeth, and their offset amount is reduced.
- Ranges in which the transmission operates in slipping lockup and full lockup states are widened.

3. WEIGHT REDUCTION

- An aluminum bearing plate is used.
- The planetary carrier, clutch drum and the hub are made of aluminum.
- The wall thickness of the transmission case is reduced.

D: CONVENTIONAL MECHANISMS

- The transfer is provided with a VTD (Variable Torque Distribution) system which consists of a planetary gear type center differential and a hydraulic multi-plated LSD, to electronically control the differential operation and improve safety and drivability.

CROSS SECTIONAL VIEW

AUTOMATIC TRANSMISSION

2. Cross Sectional View

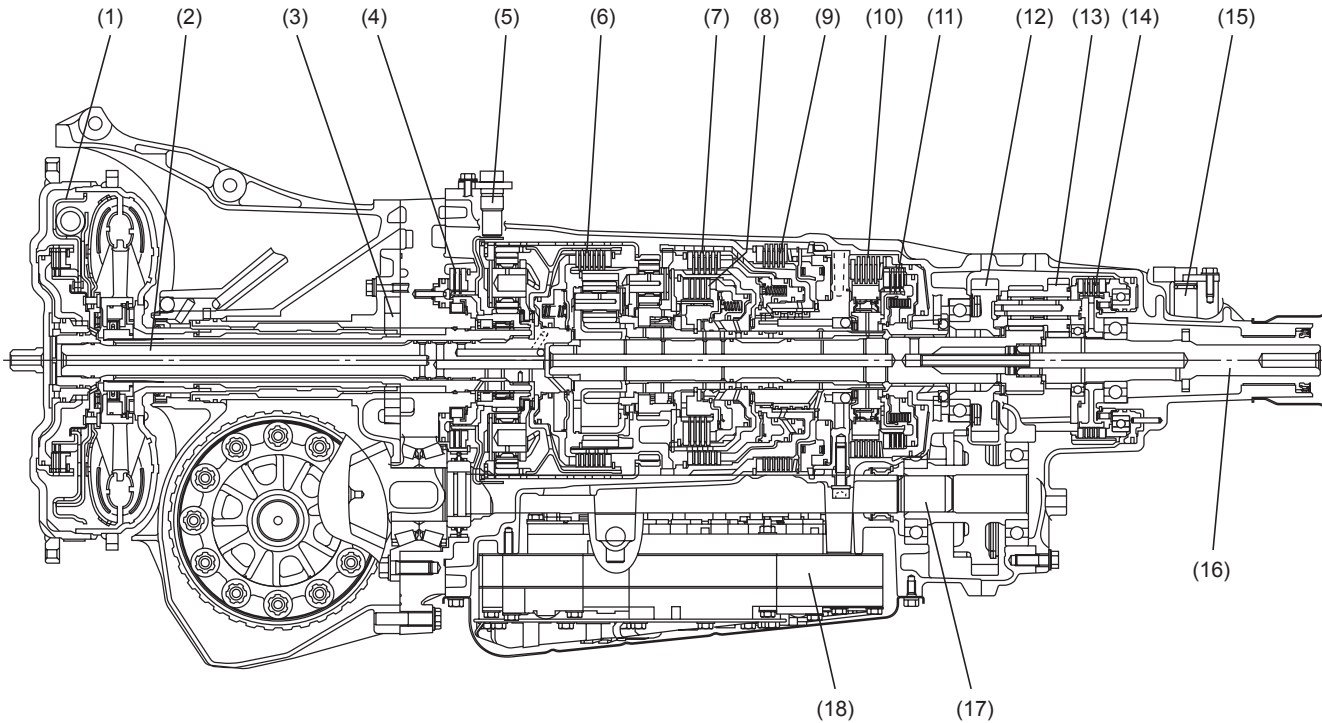

AT-02812

- | | |
|---------------------------------|---|
| (1) Torque converter assembly | (10) Forward brake |
| (2) Input shaft | (11) Low coast brake |
| (3) Oil pump | (12) Reduction gear |
| (4) Front brake | (13) Variable torque distribution (VTD) |
| (5) Turbine speed sensor 1 | (14) Transfer clutch |
| (6) Input clutch | (15) Rear vehicle speed sensor |
| (7) Direct clutch | (16) Rear drive shaft |
| (8) High and low reverse clutch | (17) Drive pinion shaft |
| (9) Reverse brake | (18) Control valve |

3. Oil Pump

A: CONSTRUCTION

The pump consists of a inner-teeth type rotor, oil pump housing, and an oil pump cover. The inner rotor has nine teeth and the outer rotor has ten teeth.

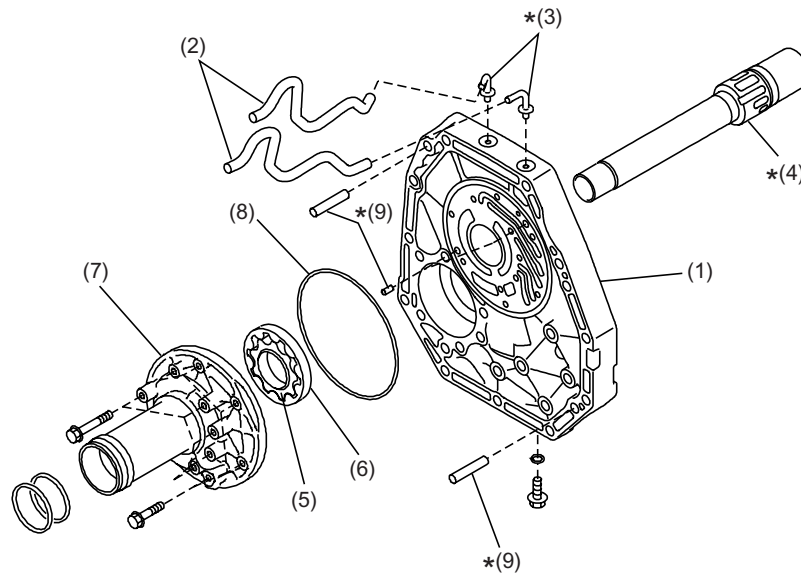

AT-02066

- | | |
|-----------------------|---------------------------------------|
| (1) Oil pump cover | (6) Outer rotor |
| (2) Air breather hose | (7) Oil pump housing |
| (3) Nipple | (8) O-ring |
| (4) Stator shaft | (9) Straight pin |
| (5) Inner rotor | * : Parts that cannot be disassembled |

B: OPERATION

The inner rotor is connected to the engine crankshaft via a oil pump shaft, impeller side of the torque converter, and drive plate; when the inner rotor turns the outer rotor also turns.

Since the number of teeth on the inner rotor and outer rotor are not the same, a space is formed between the inner rotor and outer rotor and its capacity changes as the rotors turn. Oil is drawn in when the capacity is large and is compressed and discharged when the capacity becomes smaller.

FRONT BRAKE

AUTOMATIC TRANSMISSION

4. Front Brake

A: CONSTRUCTION

The front brake consists of a front brake piston, return spring, drive plates, driven plates, and a retaining plate.

This brake engages to lock the front sun gear when engine braking is used in the 1st, 2nd and 3rd speeds and in the 5th speed and reverse range.

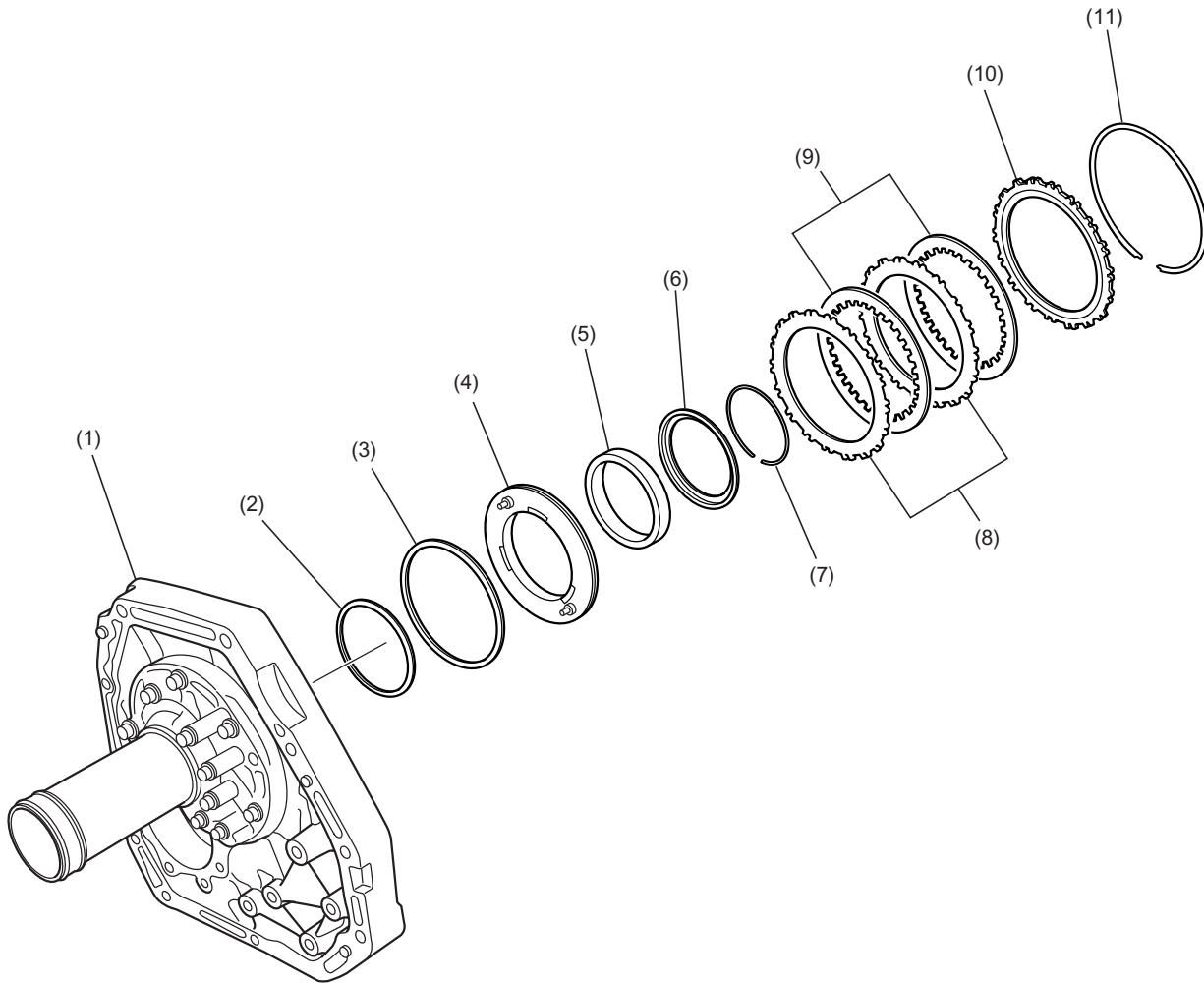

AT-01560

- (1) Oil pump housing
- (2) D-ring (inner)
- (3) D-ring (outer)
- (4) Front brake piston

- (5) Return spring
- (6) Retainer
- (7) Snap ring
- (8) Driven plate

- (9) Drive plate
- (10) Retaining plate
- (11) Snap ring

5. Input Clutch

A: CONSTRUCTION

The input clutch consists of an input clutch piston, retainer spring, drive plates, driven plates, and a retaining plate.

This clutch engages to connect the front internal gear and mid internal gear in the 4th and 5th speeds.

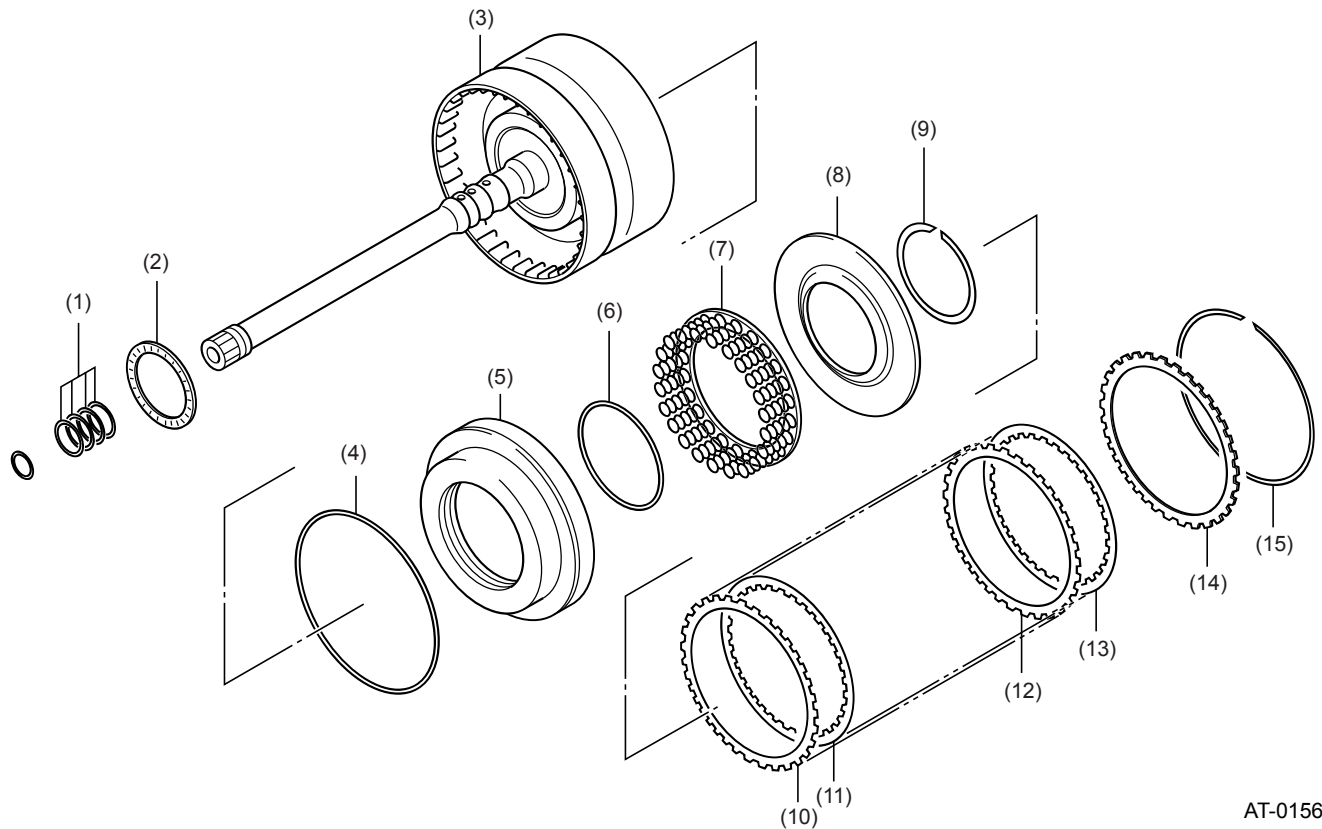

AT-01561

- | | | |
|-------------------------|--------------------|----------------------|
| (1) Seal ring | (6) D-ring (inner) | (11) Drive plate |
| (2) Thrust bearing | (7) Return spring | (12) Driven plate |
| (3) Input clutch drum | (8) Cover | (13) Drive plate |
| (4) D-ring (outer) | (9) Snap ring | (14) Retaining plate |
| (5) Input clutch piston | (10) Driven plate | (15) Snap ring |

DIRECT CLUTCH

AUTOMATIC TRANSMISSION

6. Direct Clutch

A: CONSTRUCTION

The direct clutch consists of a direct clutch piston, retainer spring, drive plates, driven plates, and a retaining plate.

This clutch engages to connect the rear carrier and rear sun gear in the 2nd, 3rd and 4th speeds.

(The direct clutch cannot be disassembled.)

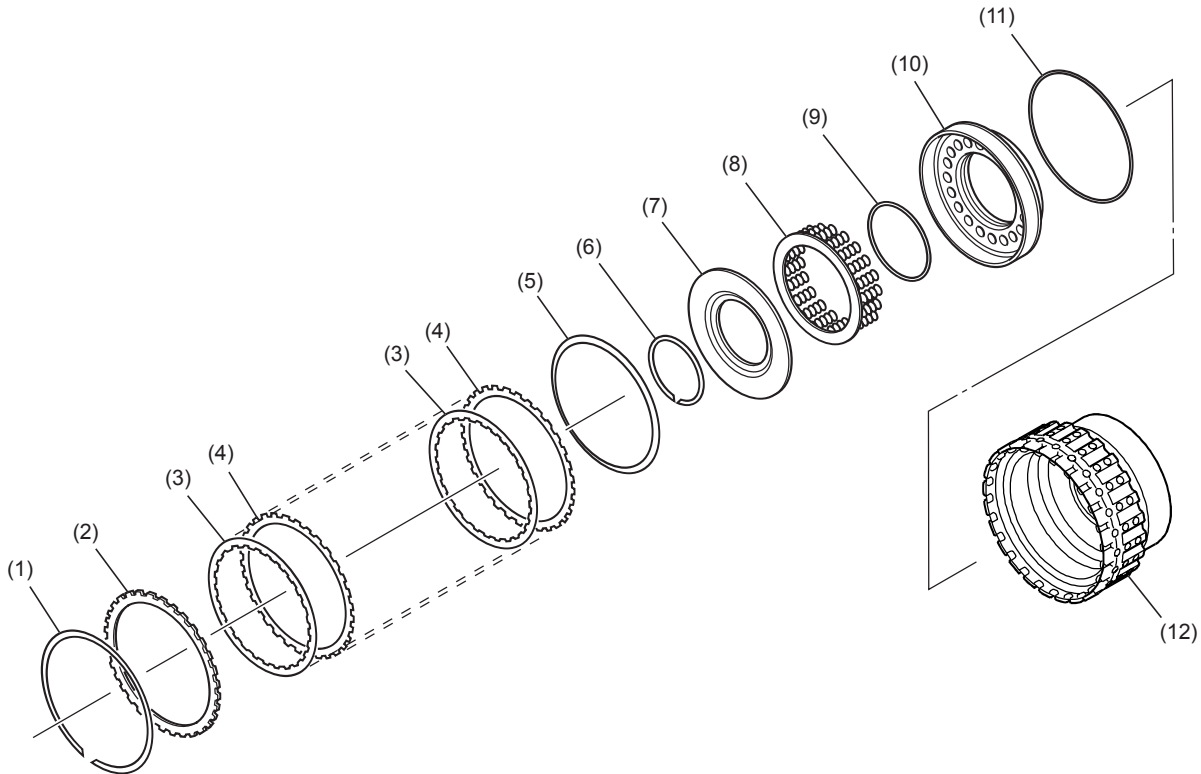

AT-01562

- | | | |
|---------------------|-------------------|---------------------------|
| (1) Snap ring | (5) Dish plate | (9) D-ring (inner) |
| (2) Retaining plate | (6) Snap ring | (10) Direct clutch piston |
| (3) Drive plate | (7) Cover | (11) D-ring (outer) |
| (4) Driven plate | (8) Return spring | (12) Direct clutch drum |

7. High and Low Reverse Clutch

A: CONSTRUCTION

The high and low reverse clutch consists of a high and low reverse clutch piston, retainer spring, drive plate, driven plate, and a retaining plate.

This clutch engages to fix the mid sun gear with the rear sun gear in the 3rd, 4th and 5th speeds.

It also fix the mid sun gear and rear sun gear when engine braking is used in 1st speed.

In reverse, the mid sun gear and rear sun gear are connected.

(The high & low reverse clutch cannot be disassembled.)

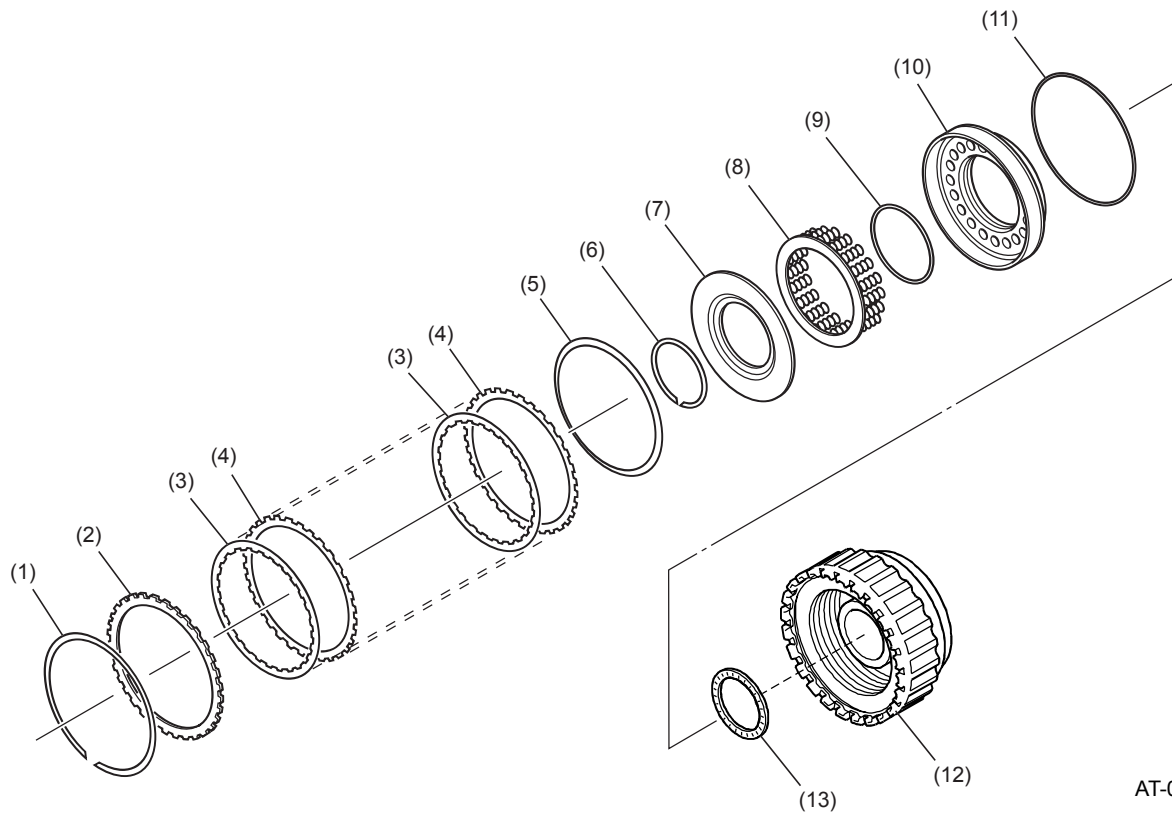

AT-01563

- (1) Snap ring
- (2) Retaining plate
- (3) Drive plate
- (4) Driven plate
- (5) Dish plate

- (6) Snap ring
- (7) Cover
- (8) Return spring
- (9) D-ring (inner)
- (10) High and low clutch piston

- (11) D-ring (outer)
- (12) High and low clutch drum
- (13) Thrust bearing

REVERSE BRAKE

AUTOMATIC TRANSMISSION

8. Reverse Brake

A: CONSTRUCTION

The reverse brake which consists of a reverse brake piston, return spring, dish plate, drive plates, driven plates and retaining plate, is placed in a housing formed in the transmission case.

This brake fixes the rear carrier in reverse range.

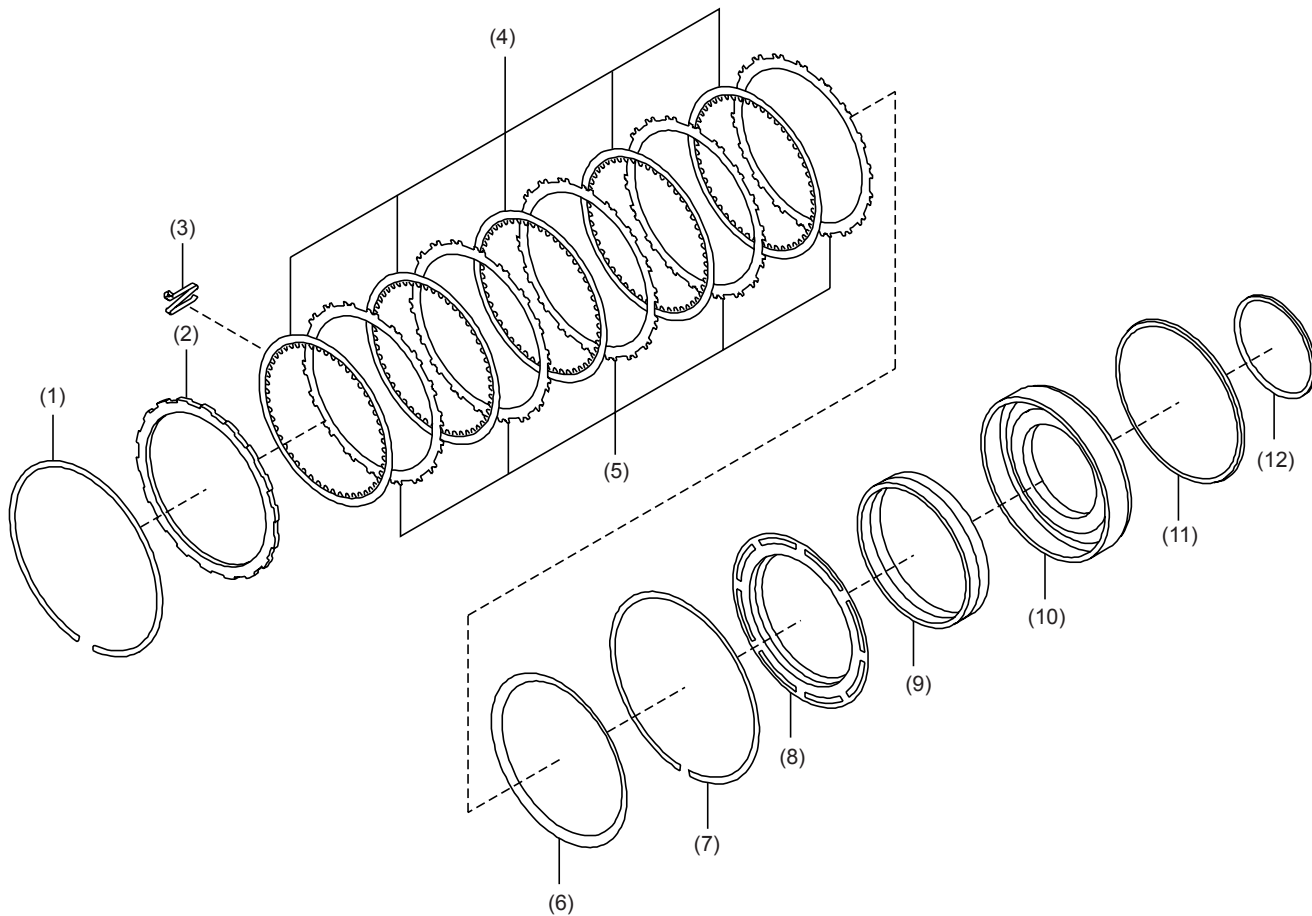

AT-01564

- | | | |
|--------------------|------------------|---------------------------|
| (1) Snap ring | (5) Driven plate | (9) Return spring |
| (2) Retainer plate | (6) Dish plate | (10) Reverse brake piston |
| (3) Leaf spring | (7) Snap ring | (11) D-ring (outer) |
| (4) Drive plate | (8) Retainer | (12) D-ring (inner) |

9. Forward Brake

A: CONSTRUCTION

The forward brake consists of a forward brake hub, forward brake piston, dish plate, drive plates, driven plates, and a retaining plate.

The forward brake restricts the reverse rotation of the mid sun gear in 1st and 2nd speeds.

(The forward brake cannot be disassembled.)

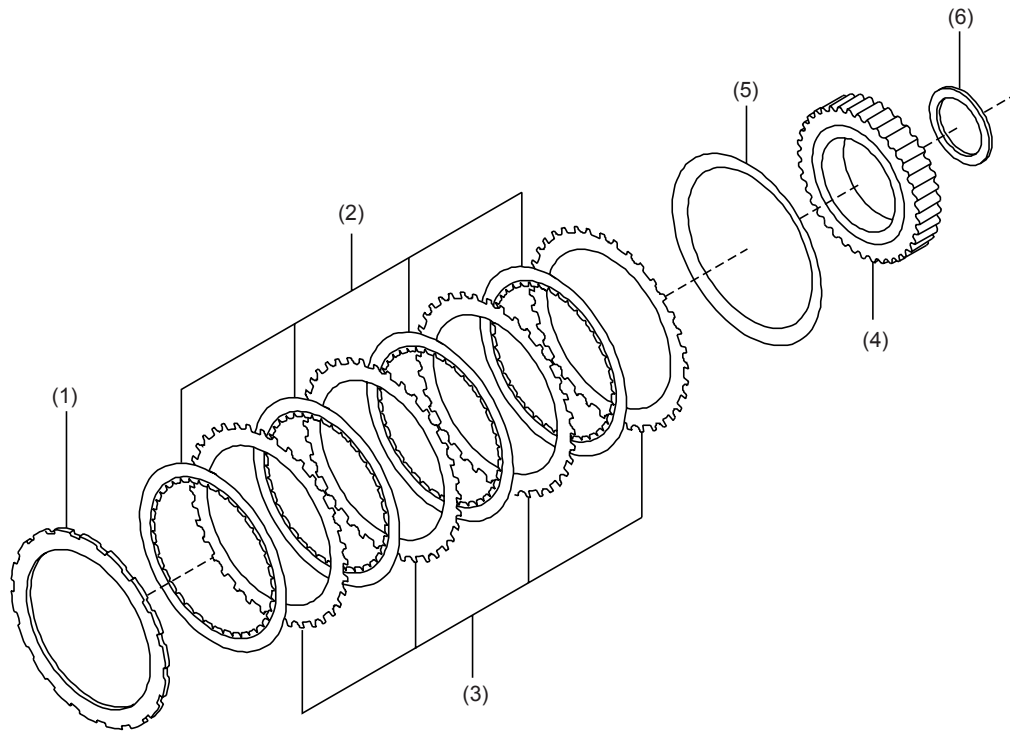

AT-01565

- (1) Retainer plate
- (2) Drive plate
- (3) Driven plate

- (4) Forward brake hub
- (5) Dish plate
- (6) Thrust bearing

10.Low Coast Brake

A: CONSTRUCTION

The low coast brake consists of a low coast brake hub, low coast piston, drive plates, driven plates, and a retaining plate.

The low coast brake restricts the reverse rotation of the mid sun gear when engine braking is used in 1st and 2nd speeds of the manual mode.

(The low coast brake cannot be disassembled.)

LOW COAST BRAKE

AUTOMATIC TRANSMISSION

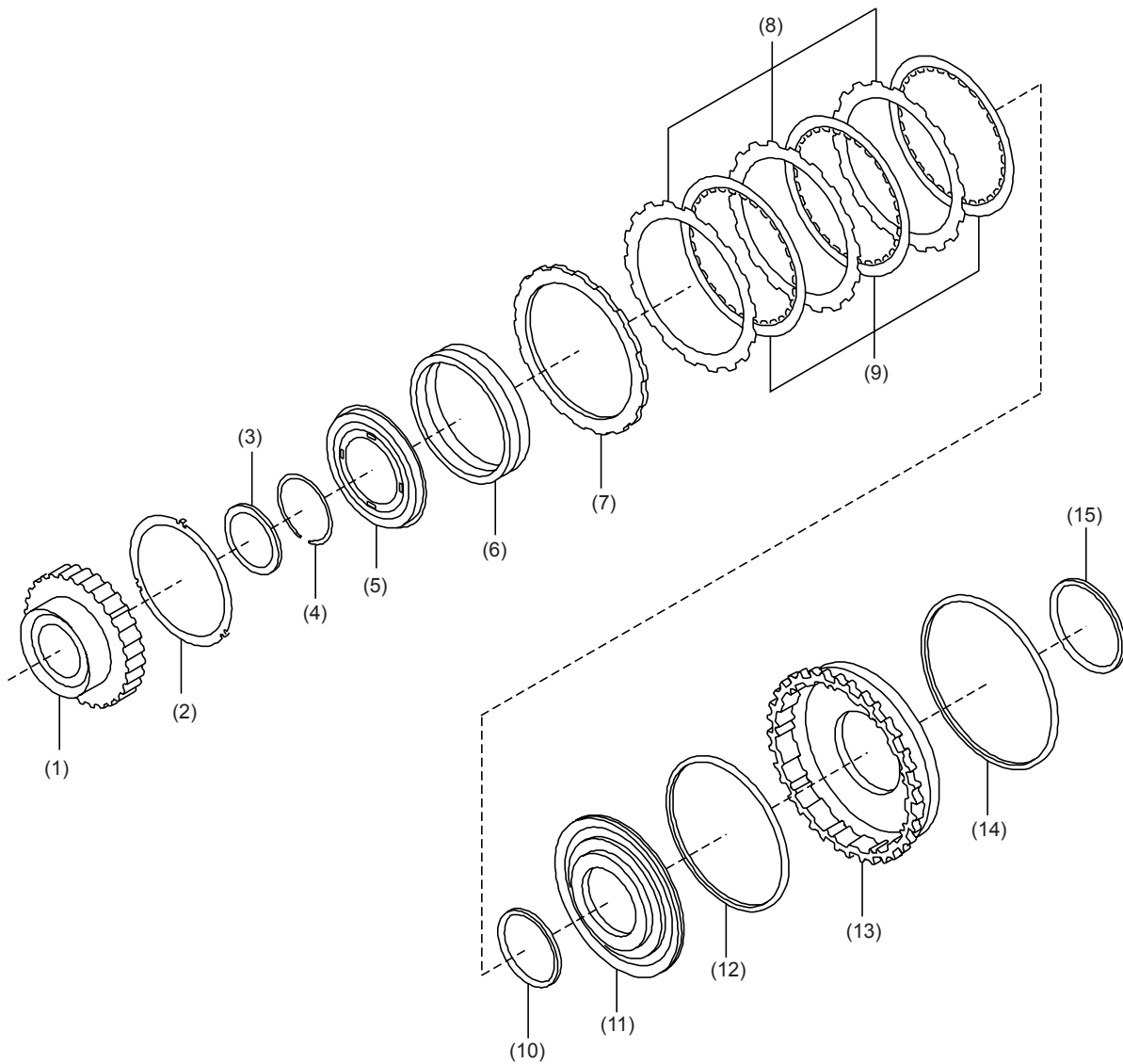

AT-01566

- (1) Low coast brake hub
- (2) Washer
- (3) Thrust bearing
- (4) Snap ring
- (5) Retainer

- (6) Return spring
- (7) Retainer plate
- (8) Driven plate
- (9) Drive plate
- (10) D-ring (inner)

- (11) Low coast brake piston
- (12) D-ring (outer)
- (13) Forward brake piston
- (14) D-ring (outer)
- (15) D-ring (inner)

CONTROL VALVE

AUTOMATIC TRANSMISSION

11.Control Valve

The control system of the automatic transmission consists of an oil pump, valve bodies containing valves, clutches, and fluid passages. The operation of the system is controlled by driver's manual inputs and electrical inputs from the TCM.

A: FUNCTION

Name	Function
<ul style="list-style-type: none"> • Torque converter regulator valve 	Regulates the line pressure to an optimum level (torque converter operating pressure) to prevent excessive torque converter supply pressure.
<ul style="list-style-type: none"> • Pressure regulator valve • Pressure regulator plug • Pressure regulator sleeve 	Regulates the pressure of oil discharged from the oil pump to an optimum level (line pressure) which is suitable for the vehicle's running condition.
<ul style="list-style-type: none"> • Front brake control valve 	Regulates the line pressure to an optimum level (front brake pressure) when the front brake is engaged, and supplies this pressure to the front brake. (regulates clutch pressure in 1st, 2nd, 3rd and 5th speeds)
<ul style="list-style-type: none"> • Accumulator control valve 	Regulates the pressure to the accumulator piston and low coast reducing valve (accumulator control pressure) in accordance with the vehicle's running condition.
<ul style="list-style-type: none"> • Pilot valve A 	Regulates the line pressure to create a constant pressure (pilot pressure) necessary for line pressure control, gear shift control, and lockup control.
<ul style="list-style-type: none"> • Pilot valve B 	Regulates the line pressure to create a constant pressure (pilot pressure) necessary for gear shift control.
<ul style="list-style-type: none"> • Low coast brake switch valve 	Supplies line pressure to the low coast brake reducing valve when engine braking is used.
<ul style="list-style-type: none"> • Low coast brake reducing valve 	Regulates the line pressure to an optimum level (low coast brake pressure) when the low coast brake is engaged, and supplies this pressure to the low coast brake.
<ul style="list-style-type: none"> • N-R accumulator 	Builds a shelf-pressure when N-R is selected.
<ul style="list-style-type: none"> • Direct clutch piston switching valve 	Operates in 4th speed and switches the engaging capacity of the direct clutch.
<ul style="list-style-type: none"> • High and low reverse clutch control valve 	Regulates the line pressure to an optimum level (high and low reverse clutch pressure) when the high and low reverse clutch is engaged, and supplies this pressure to the high and low reverse clutch. (regulates clutch pressure in 1st, 2nd, 4th and 5th speeds)
<ul style="list-style-type: none"> • Input clutch control valve 	Regulates the line pressure to an optimum level (input clutch pressure) when the input clutch is engaged, and supplies this pressure to the input clutch. (regulates clutch pressure in 4th and 5th speeds)
<ul style="list-style-type: none"> • Direct clutch control valve 	Regulates the line pressure to an optimum level (direct clutch pressure) when the direct clutch is engaged, and supplies this pressure to the direct clutch. (regulates clutch pressure in 2nd, 3rd and 4th speeds)
<ul style="list-style-type: none"> • Lockup control valve • Lockup control plug • Lockup control sleeve 	Engages or releases lockup. It also provides a smooth lockup by performing lockup gradually.
<ul style="list-style-type: none"> • Torque converter lubrication valve 	Operates when lockup is engaged and switches the oil passages of the torque converter, cooling and lubrication systems.
<ul style="list-style-type: none"> • Cooler bypass valve 	Detours excessive cooler circuit oil.
<ul style="list-style-type: none"> • Line pressure relief valve 	Drains excessive line pressure circuit oil.
<ul style="list-style-type: none"> • N-D accumulator 	Builds a shelf-pressure when N-D is selected.
<ul style="list-style-type: none"> • Manual valve 	Delivers line pressure to the circuits according to the selected position. Circuits, which are not delivered with line pressure becomes drain.

CONTROL VALVE

AUTOMATIC TRANSMISSION

Name	Function
• Front brake hydraulic switch	Monitors front brake oil pressure and lets the system enter the fail safe mode if abnormality is found.
• Low coast brake hydraulic switch	Monitors low coast brake oil pressure and lets the system enter the fail safe mode if abnormality is found.
• Input clutch hydraulic switch	Monitors input clutch oil pressure and lets the system enter the fail safe mode if abnormality is found.
• Direct clutch hydraulic switch	Monitors direct clutch oil pressure and lets the system enter the fail safe mode if abnormality is found.
• High and low reverse clutch hydraulic switch	Monitors high and low reverse clutch oil pressure and let the system enter the fail safe mode if abnormality is found.

B: ARRANGEMENT

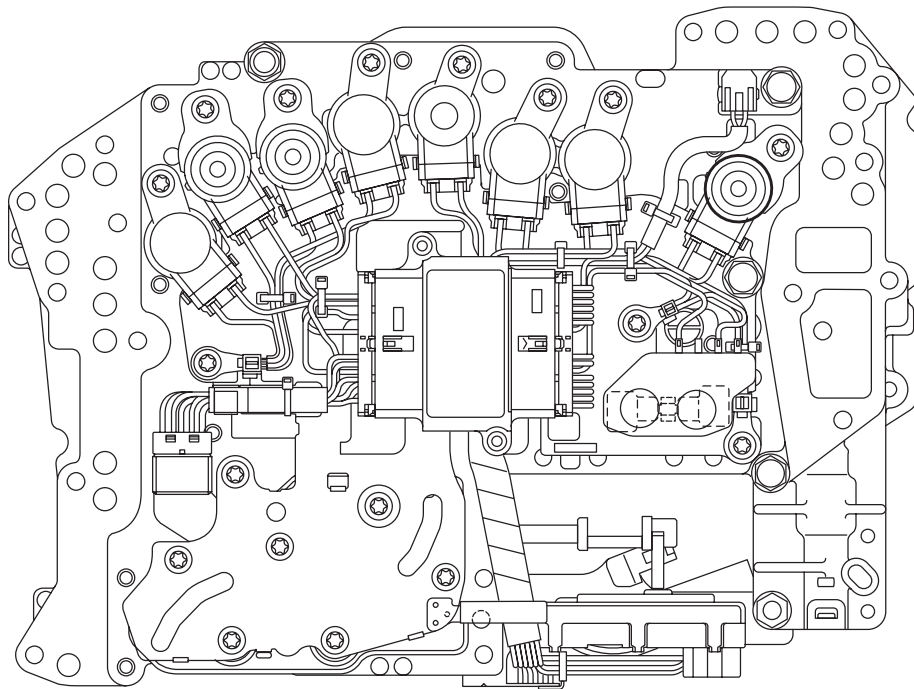

AT-01551

GEAR TRAIN

AUTOMATIC TRANSMISSION

12.Gear Train

A: CONSTRUCTION

The gear train consists of three sets of planetary gears, three sets of multi-plate clutches, four sets of multi-plate brakes and three set of one-way clutches.

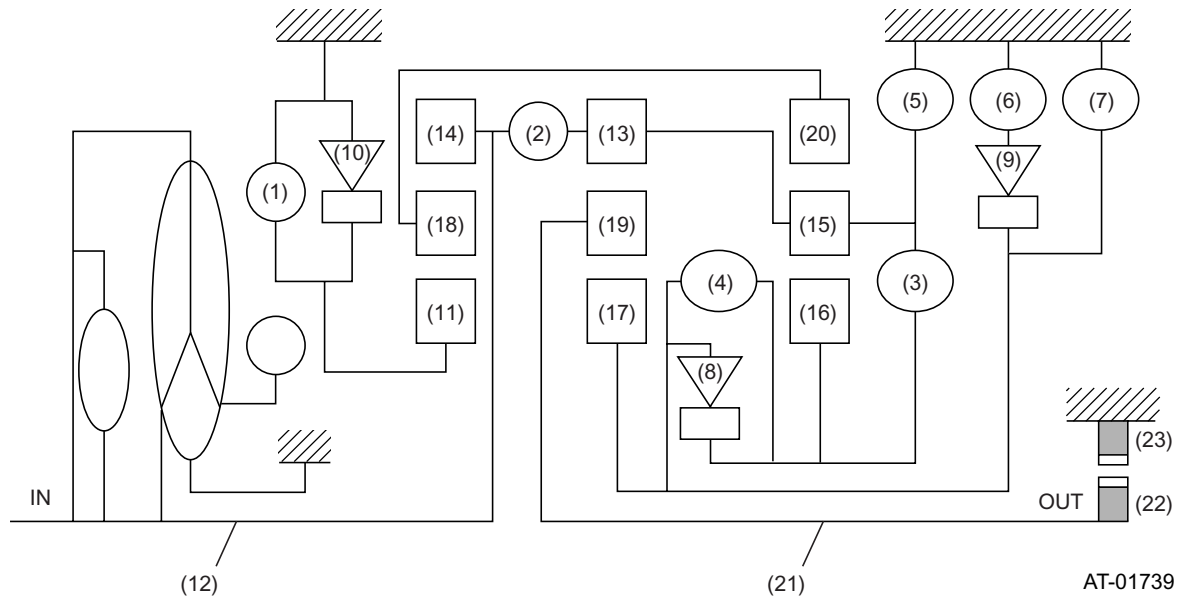

- | | | |
|---------------------------------|----------------------------|-------------------------|
| (1) Front brake | (9) Forward one-way clutch | (17) Mid sun gear |
| (2) Input clutch | (10) 3rd one-way clutch | (18) Front carrier |
| (3) Direct clutch | (11) Front sun gear | (19) Mid carrier |
| (4) High and low reverse clutch | (12) Input shaft | (20) Rear internal gear |
| (5) Reverse brake | (13) Mid internal gear | (21) Output shaft |
| (6) Forward brake | (14) Front internal gear | (22) Parking gear |
| (7) Low coast brake | (15) Rear carrier | (23) Parking pawl |
| (8) 1st one-way clutch | (16) Rear sun gear | |

B: OPERATION

1. OPERATION TABLE

		Input clutch	High & low reverse clutch	Direct clutch	Reverse brake	Front brake	Low coast brake	Forward brake	1st one-way clutch	Forward one-way clutch	3rd one-way clutch	
Select lever position	(P)		△			△						
	(R)		○		○	○			◎		◎	
	(N)		△			△						
	(D)	1st		△*			△	△*◇*	○	◎	◎	◎
		↑↓ 2nd			○		△	◇*	○		◎	◎
		↑↓ 3rd		○	○		○		△	◇		◎
↑↓ 4th		○	○	○				△	◇			
↑↓ 5th		○	○			○		△	◇		◇	

- : Engaged
- ◎ : Participates in torque transmission only when driven
- ◇ : Participates in torque transmission only when coasting
- ◇* : Engaged in sports mode
- △ : Engaged but no effect to output
- △* : Engaged when vehicle speed is within certain range

AT-02094

2. N RANGE

Since the forward and reverse brakes are disengaged, driving power from the input shaft is not transmitted to the output shaft.

GEAR TRAIN

AUTOMATIC TRANSMISSION

3. P RANGE

- Since the forward and reverse brakes are disengaged as in the N range, driving power from the input shaft is not transmitted to the output shaft.
- The parking pawl, which is linked with the selector lever engages with the parking gear and mechanically holds the output shaft.

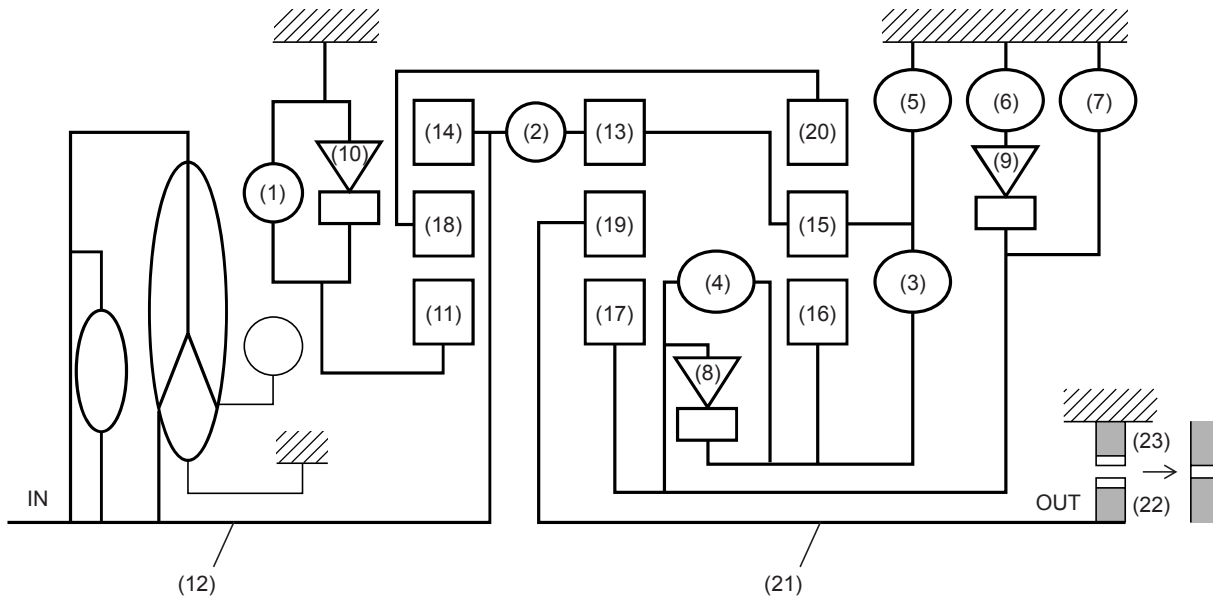

AT-01741

- | | | |
|---------------------------------|----------------------------|-------------------------|
| (1) Front brake | (9) Forward one-way clutch | (17) Mid sun gear |
| (2) Input clutch | (10) 3rd one-way clutch | (18) Front carrier |
| (3) Direct clutch | (11) Front sun gear | (19) Mid carrier |
| (4) High and low reverse clutch | (12) Input shaft | (20) Rear internal gear |
| (5) Reverse brake | (13) Mid internal gear | (21) Output shaft |
| (6) Forward brake | (14) Front internal gear | (22) Parking gear |
| (7) Low coast brake | (15) Rear carrier | (23) Parking pawl |
| (8) 1st one-way clutch | (16) Rear sun gear | |

4. 1st SPEED GEAR OF D RANGE

- The forward brake and forward one-way clutch operates to control the reverse rotation of the mid sun gear.
- The 1st one-way clutch operates to control the reverse rotation of the rear sun gear.
- The 3rd one-way clutch operates to control the reverse rotation of the front sun gear.
- As the mid sun gear spins during deceleration, the forward one-way clutch spins and engine braking effect will not be available.

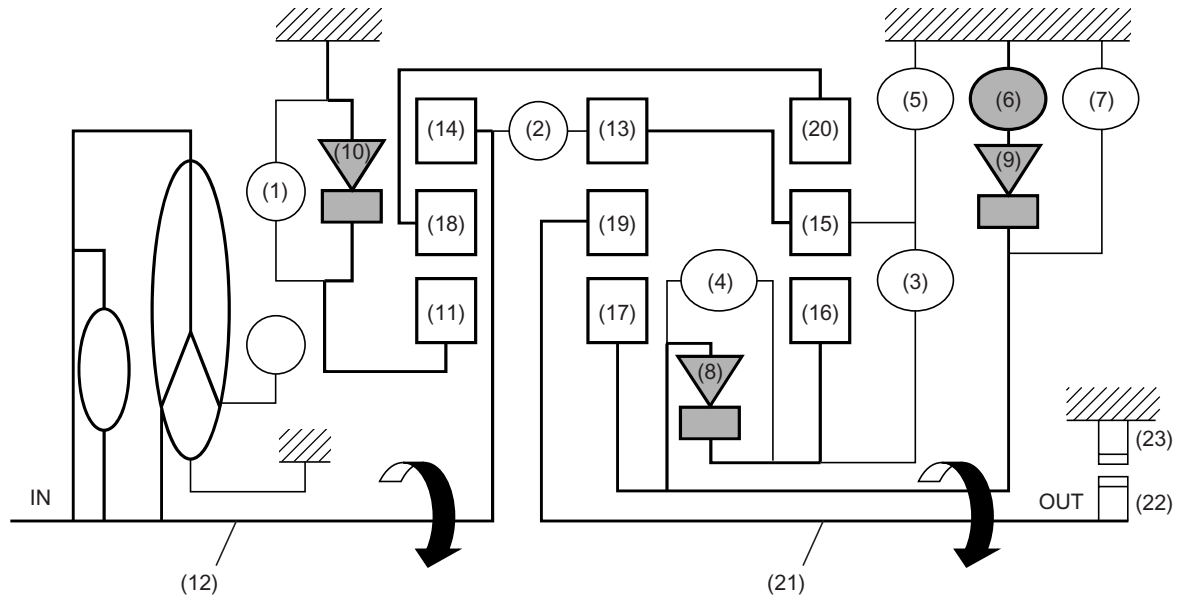

Power flow

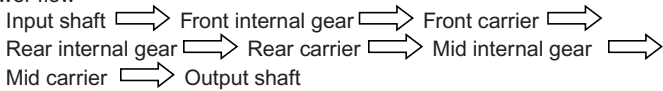

AT-01929

- | | | |
|---------------------------------|----------------------------|-------------------------|
| (1) Front brake | (9) Forward one-way clutch | (17) Mid sun gear |
| (2) Input clutch | (10) 3rd one-way clutch | (18) Front carrier |
| (3) Direct clutch | (11) Front sun gear | (19) Mid carrier |
| (4) High and low reverse clutch | (12) Input shaft | (20) Rear internal gear |
| (5) Reverse brake | (13) Mid internal gear | (21) Output shaft |
| (6) Forward brake | (14) Front internal gear | (22) Parking gear |
| (7) Low coast brake | (15) Rear carrier | (23) Parking pawl |
| (8) 1st one-way clutch | (16) Rear sun gear | |

GEAR TRAIN

AUTOMATIC TRANSMISSION

5. 1st SPEED GEAR OF MANUAL MODE

- The front brake operates to hold the front sun gear.
- The forward brake and forward one-way clutch operates to control the reverse rotation of the mid sun gear.
- The high and low reverse clutch operates to engage the rear sun gear and the mid sun gear.
- The low coast brake operates to hold the mid sun gear.
- During deceleration, the low coast brake controls the reverse rotation of the mid sun gear and engine braking effect will be available.

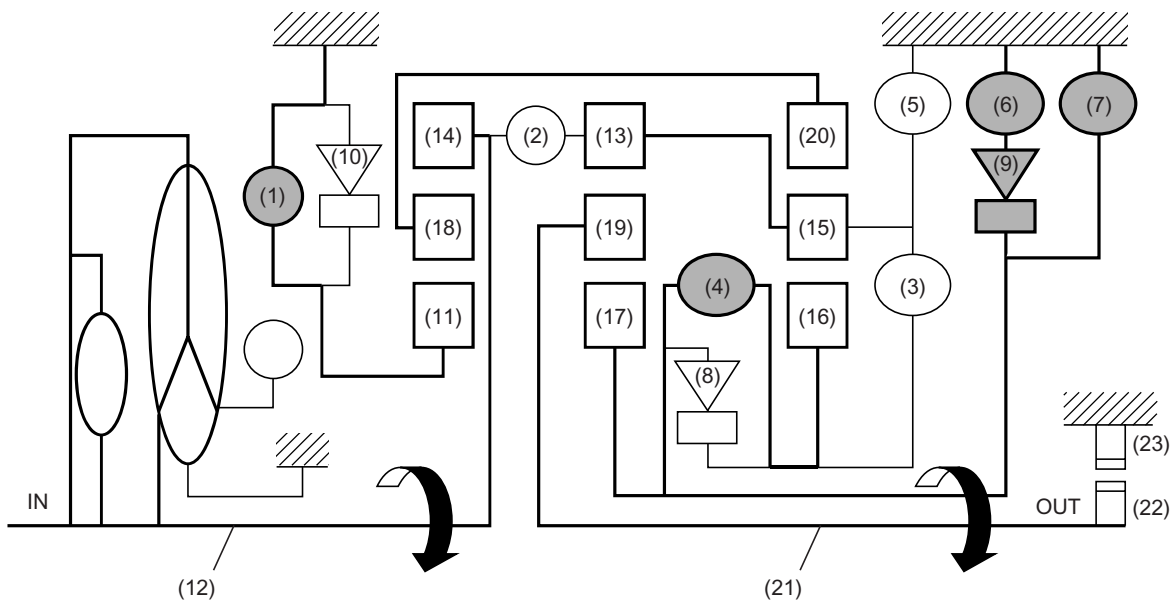

Power flow

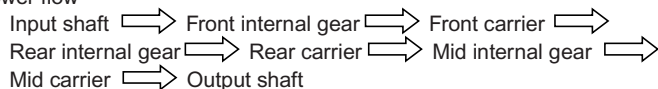

AT-01934

- | | | |
|---------------------------------|----------------------------|-------------------------|
| (1) Front brake | (9) Forward one-way clutch | (17) Mid sun gear |
| (2) Input clutch | (10) 3rd one-way clutch | (18) Front carrier |
| (3) Direct clutch | (11) Front sun gear | (19) Mid carrier |
| (4) High and low reverse clutch | (12) Input shaft | (20) Rear internal gear |
| (5) Reverse brake | (13) Mid internal gear | (21) Output shaft |
| (6) Forward brake | (14) Front internal gear | (22) Parking gear |
| (7) Low coast brake | (15) Rear carrier | (23) Parking pawl |
| (8) 1st one-way clutch | (16) Rear sun gear | |

6. 2nd SPEED GEAR OF D RANGE

- The forward brake and forward one-way clutch operates to control the reverse rotation of the mid sun gear.
- The 3rd one-way clutch operates to control the reverse rotation of the front sun gear.
- The direct clutch engages to connect the rear carrier and rear sun gear.
- As the mid sun gear spins during deceleration, the forward one-way clutch spins and engine braking effect will not be available.

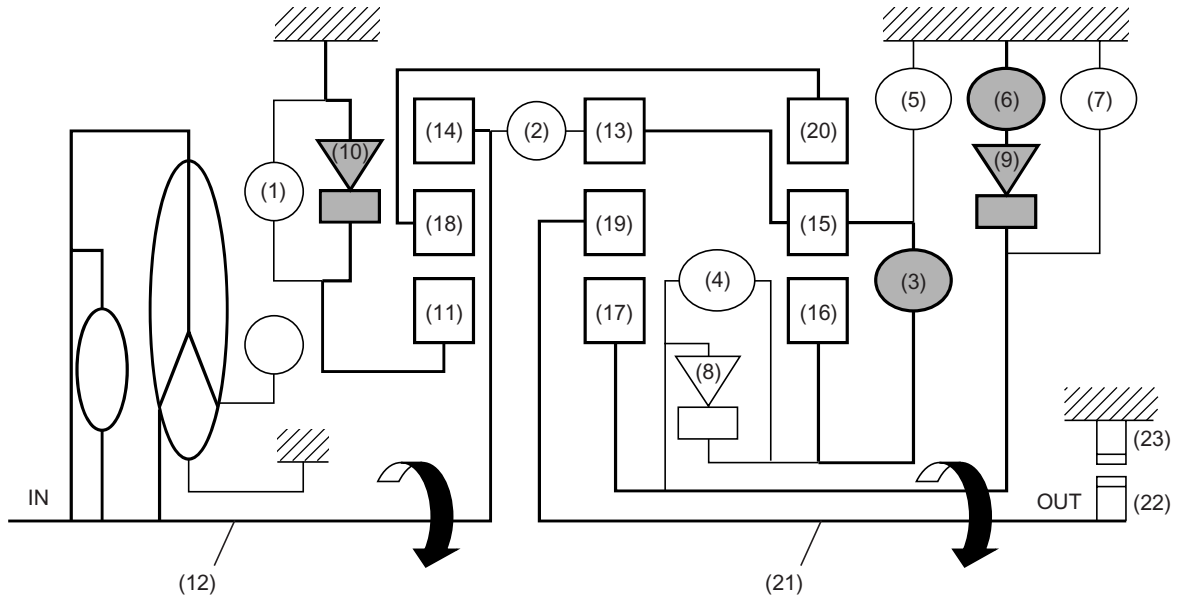

Power flow
 Input shaft → Front internal gear → Front carrier →
 Rear internal gear → Rear carrier → Mid internal gear →
 Mid carrier → Output shaft

AT-01939

- | | | |
|---------------------------------|----------------------------|-------------------------|
| (1) Front brake | (9) Forward one-way clutch | (17) Mid sun gear |
| (2) Input clutch | (10) 3rd one-way clutch | (18) Front carrier |
| (3) Direct clutch | (11) Front sun gear | (19) Mid carrier |
| (4) High and low reverse clutch | (12) Input shaft | (20) Rear internal gear |
| (5) Reverse brake | (13) Mid internal gear | (21) Output shaft |
| (6) Forward brake | (14) Front internal gear | (22) Parking gear |
| (7) Low coast brake | (15) Rear carrier | (23) Parking pawl |
| (8) 1st one-way clutch | (16) Rear sun gear | |

GEAR TRAIN

AUTOMATIC TRANSMISSION

7. 2nd SPEED GEAR OF MANUAL MODE

- The front brake operates to hold the front sun gear.
- The forward brake and forward one-way clutch operates to control the reverse rotation of the mid sun gear.
- The direct clutch engages to connect the rear carrier and rear sun gear.
- The low coast brake operates to hold the mid sun gear.
- During deceleration, the low coast brake controls the reverse rotation of the mid sun gear and engine braking effect will be available.

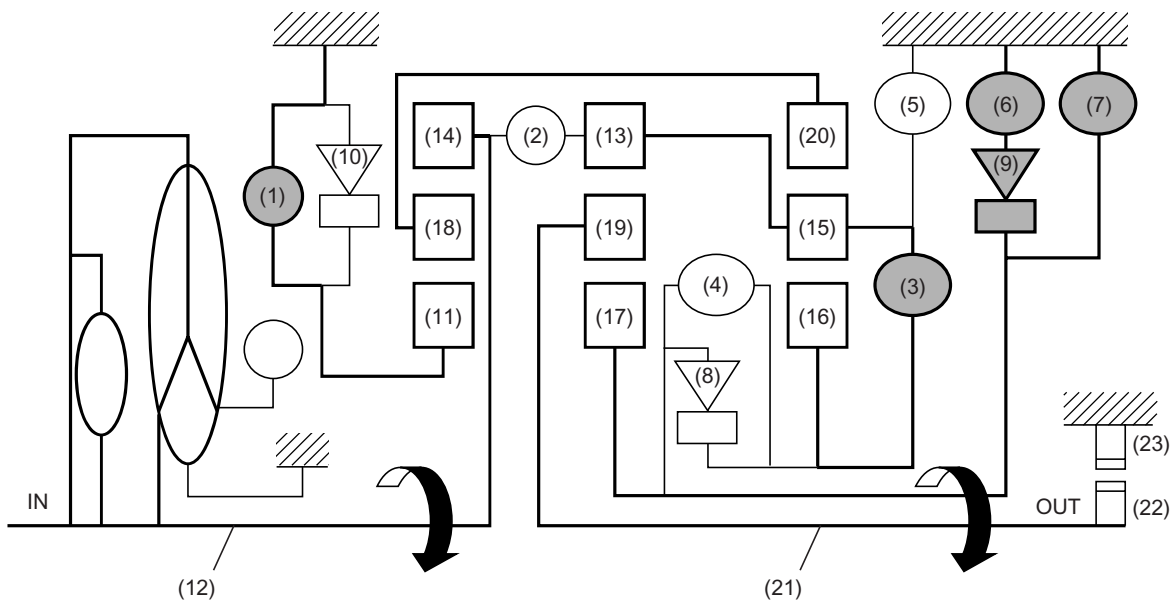

Power flow

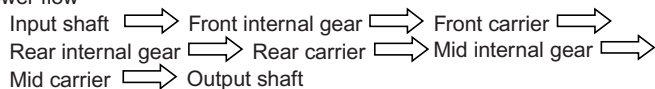

AT-01944

- | | | |
|---------------------------------|----------------------------|-------------------------|
| (1) Front brake | (9) Forward one-way clutch | (17) Mid sun gear |
| (2) Input clutch | (10) 3rd one-way clutch | (18) Front carrier |
| (3) Direct clutch | (11) Front sun gear | (19) Mid carrier |
| (4) High and low reverse clutch | (12) Input shaft | (20) Rear internal gear |
| (5) Reverse brake | (13) Mid internal gear | (21) Output shaft |
| (6) Forward brake | (14) Front internal gear | (22) Parking gear |
| (7) Low coast brake | (15) Rear carrier | (23) Parking pawl |
| (8) 1st one-way clutch | (16) Rear sun gear | |

8. 3rd SPEED GEAR OF D RANGE OR MANUAL MODE

- The front brake operates to hold the front sun gear.
- The direct clutch engages to connect the rear carrier and rear sun gear.
- The high and low reverse clutch engages to connect the mid sun gear and rear sun gear.

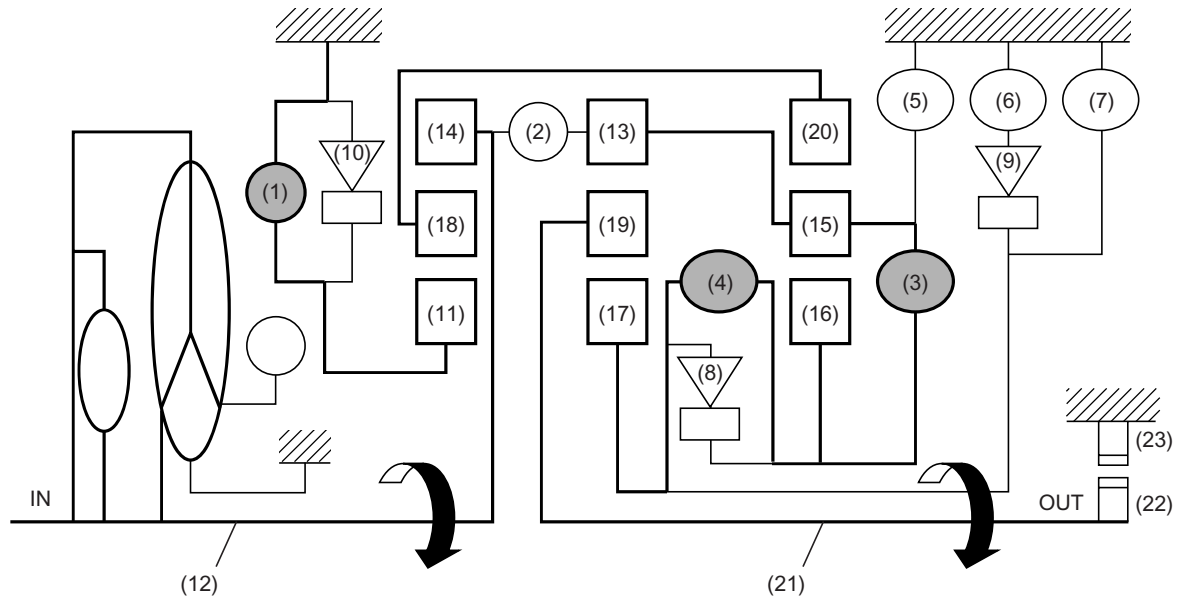

Power flow

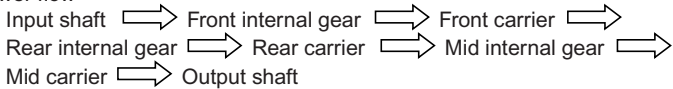

AT-01949

- | | | |
|---------------------------------|----------------------------|-------------------------|
| (1) Front brake | (9) Forward one-way clutch | (17) Mid sun gear |
| (2) Input clutch | (10) 3rd one-way clutch | (18) Front carrier |
| (3) Direct clutch | (11) Front sun gear | (19) Mid carrier |
| (4) High and low reverse clutch | (12) Input shaft | (20) Rear internal gear |
| (5) Reverse brake | (13) Mid internal gear | (21) Output shaft |
| (6) Forward brake | (14) Front internal gear | (22) Parking gear |
| (7) Low coast brake | (15) Rear carrier | (23) Parking pawl |
| (8) 1st one-way clutch | (16) Rear sun gear | |

GEAR TRAIN

AUTOMATIC TRANSMISSION

9. 4th SPEED GEAR OF D RANGE OR MANUAL MODE

- The direct clutch engages to connect the rear carrier and rear sun gear.
- The high and low reverse clutch engages to connect the mid sun gear and rear sun gear.
- The input clutch engages to connect the front internal gear and mid internal gear.
- Drive power is transmitted to the front internal gear, mid internal gear and rear carrier; the three planetary gears turn together as a unit in the normal direction.

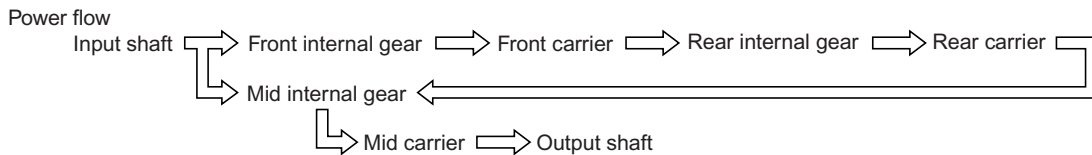
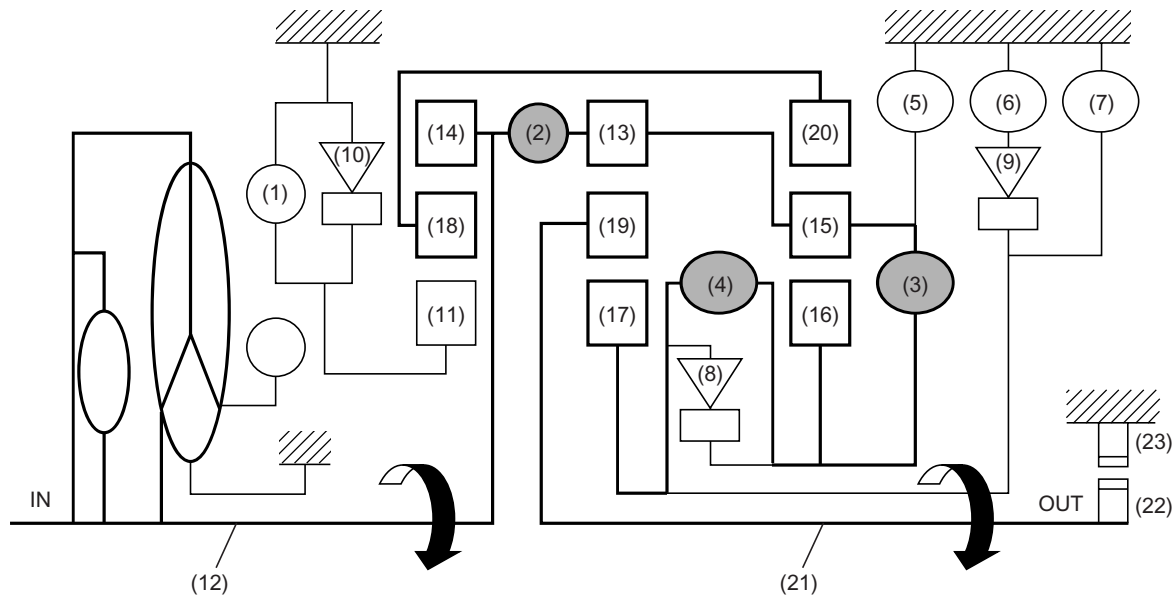

AT-02231

- | | | |
|---------------------------------|----------------------------|-------------------------|
| (1) Front brake | (9) Forward one-way clutch | (17) Mid sun gear |
| (2) Input clutch | (10) 3rd one-way clutch | (18) Front carrier |
| (3) Direct clutch | (11) Front sun gear | (19) Mid carrier |
| (4) High and low reverse clutch | (12) Input shaft | (20) Rear internal gear |
| (5) Reverse brake | (13) Mid internal gear | (21) Output shaft |
| (6) Forward brake | (14) Front internal gear | (22) Parking gear |
| (7) Low coast brake | (15) Rear carrier | (23) Parking pawl |
| (8) 1st one-way clutch | (16) Rear sun gear | |

10.5th SPEED GEAR OF D RANGE OR MANUAL MODE

- The front brake operates to hold the front sun gear.
- The input clutch engages to connect the front internal gear and mid internal gear.
- The high and low reverse clutch engages to connect the mid sun gear and rear sun gear.

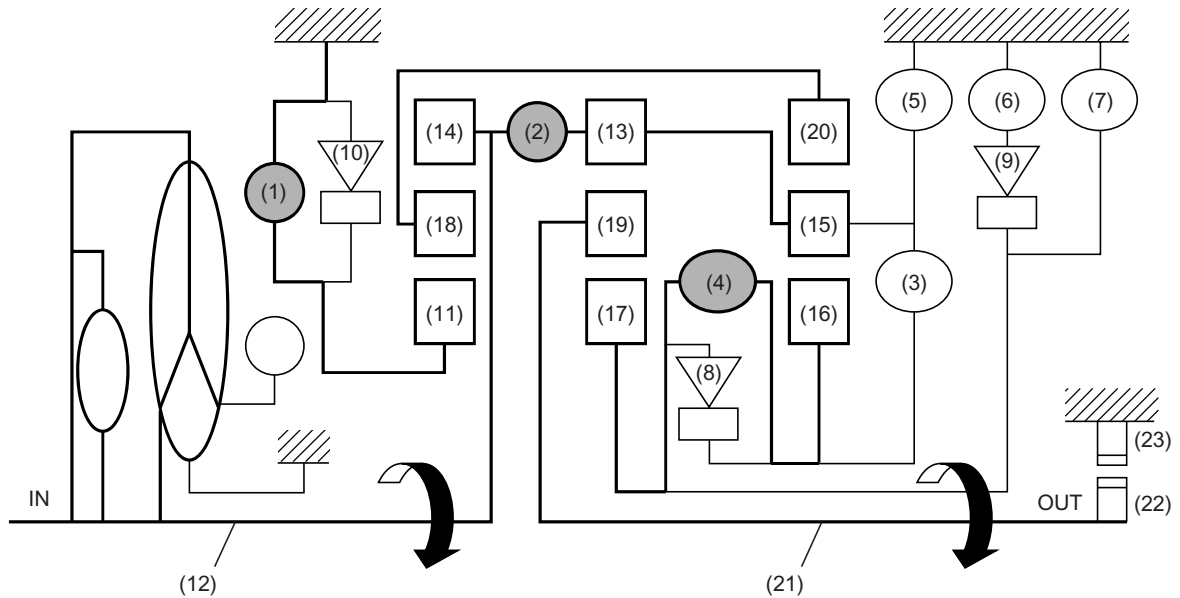

Power flow

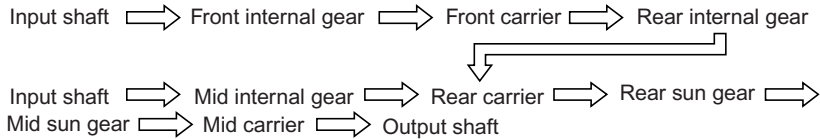

AT-02236

- | | | |
|---------------------------------|----------------------------|-------------------------|
| (1) Front brake | (9) Forward one-way clutch | (17) Mid sun gear |
| (2) Input clutch | (10) 3rd one-way clutch | (18) Front carrier |
| (3) Direct clutch | (11) Front sun gear | (19) Mid carrier |
| (4) High and low reverse clutch | (12) Input shaft | (20) Rear internal gear |
| (5) Reverse brake | (13) Mid internal gear | (21) Output shaft |
| (6) Forward brake | (14) Front internal gear | (22) Parking gear |
| (7) Low coast brake | (15) Rear carrier | (23) Parking pawl |
| (8) 1st one-way clutch | (16) Rear sun gear | |

GEAR TRAIN

AUTOMATIC TRANSMISSION

11. R RANGE

- The front brake operates to hold the front sun gear.
- The high and low reverse clutch engages to connect the mid sun gear and rear sun gear.
- The reverse brake operates to hold the rear carrier.

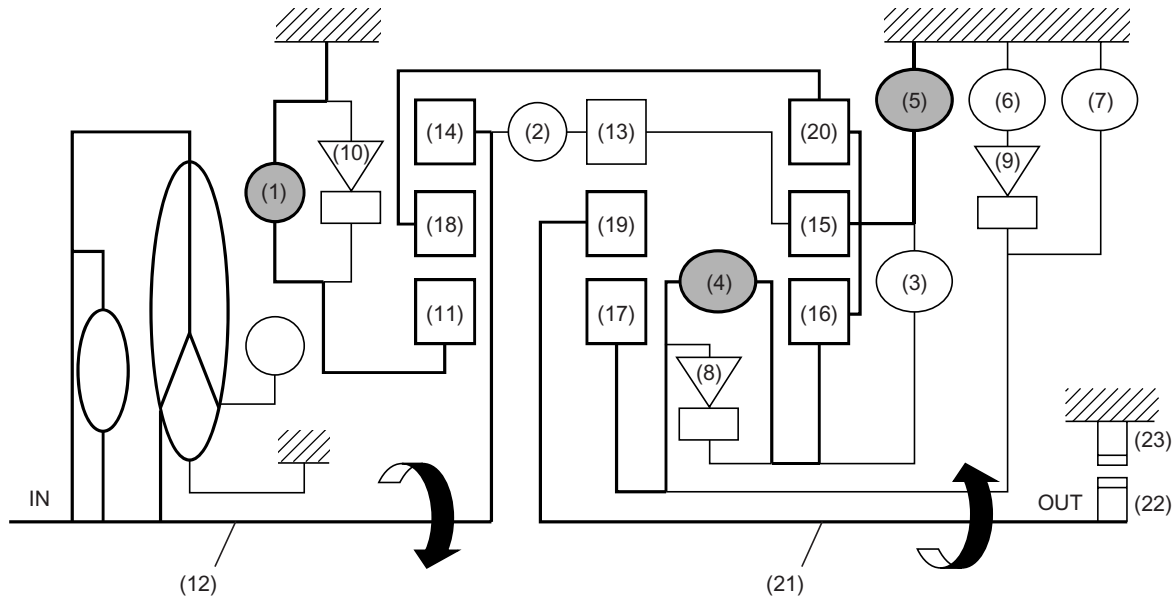

Power flow

Input shaft → Front internal gear → Front carrier → Rear internal gear →
 Rear sun gear → Mid sun gear → Mid carrier → Output shaft

AT-02241

- | | | |
|---------------------------------|----------------------------|-------------------------|
| (1) Front brake | (9) Forward one-way clutch | (17) Mid sun gear |
| (2) Input clutch | (10) 3rd one-way clutch | (18) Front carrier |
| (3) Direct clutch | (11) Front sun gear | (19) Mid carrier |
| (4) High and low reverse clutch | (12) Input shaft | (20) Rear internal gear |
| (5) Reverse brake | (13) Mid internal gear | (21) Output shaft |
| (6) Forward brake | (14) Front internal gear | (22) Parking gear |
| (7) Low coast brake | (15) Rear carrier | (23) Parking pawl |
| (8) 1st one-way clutch | (16) Rear sun gear | |

13.AWD Transfer System

A: GENERAL

Used in the transfer is the VTD (Variable Torque Distribution) system which combines a compound planetary gear type center differential installed in the transfer case behind the transmission and a hydraulically operated multi-plate differential action limiting device (LSD) located between the output shafts of the center differential. Differential action limiting control is performed by the TCM according to driving and road surface conditions.

The input torque is transmitted to the 1st sun gear of the center differential through the intermediate shaft. From the 1st sun gear, the torque is transmitted through the 1st pinion to the output carrier in the front wheel output shaft, and through the 2nd pinion to the 2nd sun gear in the rear wheel output shaft.

The center differential performs the differential functions of absorbing the speed difference between the front and rear wheels and also distributes drive forces to the front and rear wheels at a predetermined ratio. In normal conditions (when pressure is not applied to the multi-plate clutch), the drive force distribution ratio is 45.7 % to the front wheels and 54.3 % to the rear wheels. The hydraulic multi-plate clutch connected in parallel with the center differential between the carrier and 2nd sun gear functions as a differential action limiting device (LSD) and also as a device that controls torque distribution according to driving conditions.

Differential action limiting control is performed as a “torque responsive control”, where control is based on the input torque to the transfer as calculated from the engine torque, torque converter characteristics, gear ratio, etc. The LSD clutch is controlled by the hydraulic pressure regulated by the transfer valve in the transmission hydraulic control valve assembly, as a result of the TCM directly controlling the linear solenoid. The torque distribution ratio to front and rear wheels changes from 45.7:54.3 to direct connection, in accordance with the hydraulic pressure acting on the piston.

The speed of the front and rear wheels determine the basic signals for the differential action limiting control. The rear wheel speed is detected by the sensor installed above the rear drive shaft, and the front wheel speed is detected by the sensor on the parking gear above the reduction gear.

AWD TRANSFER SYSTEM

AUTOMATIC TRANSMISSION

B: OPERATION

The front-rear torque distribution ratio is determined by the of center differential's compound planetary gears and is varied by changing the degree of engagement of the hydraulically operated multi-plate clutch that connects the center differential output elements according to driving conditions and road surface conditions. The torque distribution ratio is calculated using the following equations, which include torque distribution coefficients (determined by number of gear teeth), input torque to the center differential, and torque capacity of the multi-plate clutch as factors.

1) When the front wheel speed is higher than the rear wheel speed:

$$T_R = 0.543 \times T_i + T_C$$

$$T_F = 0.457 \times T_i - T_C$$

where

T_R : Rear wheel output torque

T_i : Input torque to center differential

T_C : Torque capacity of multi-plate clutch

T_F : Front wheel output torque

0.543: Coefficient of rear wheel torque determined by number of gear teeth

0.457: Coefficient of front wheel torque determined by number of gear teeth

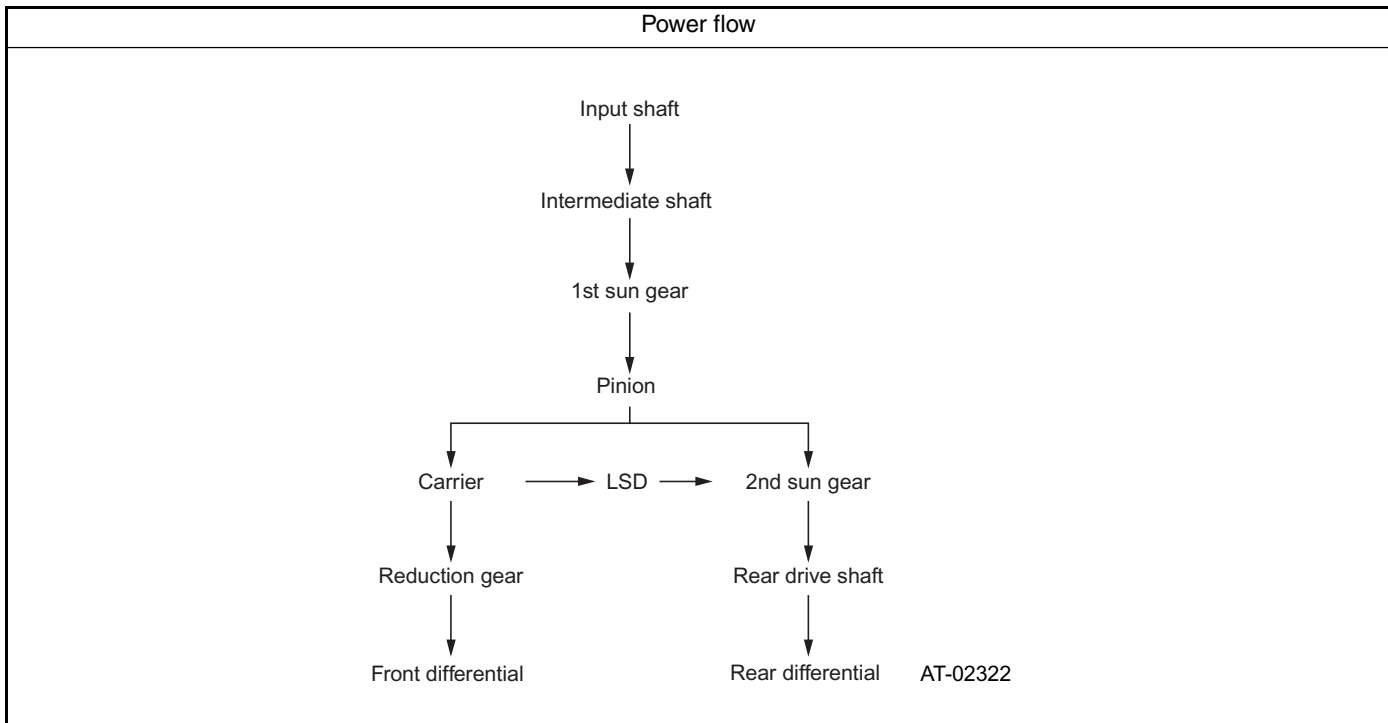

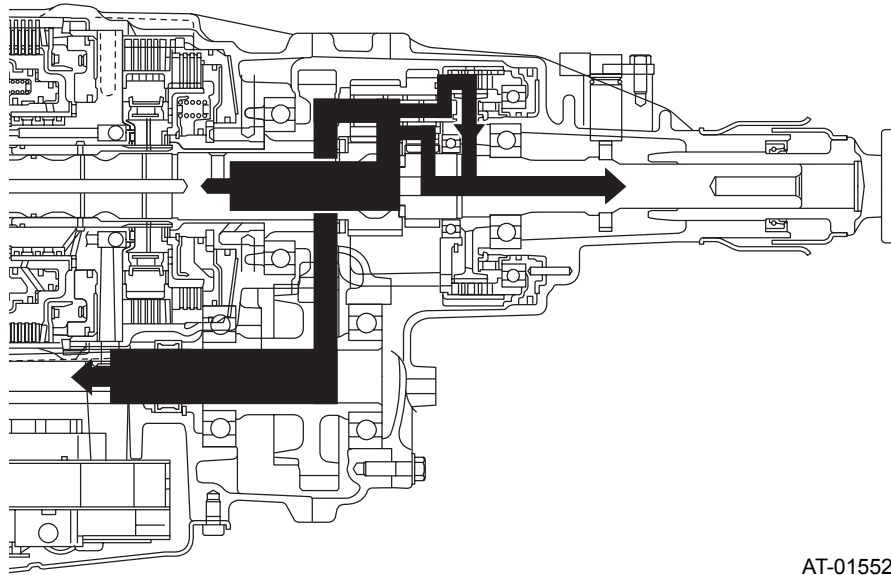

AT-01552

2) When the rear wheel speed is higher than the front wheel speed:

$$T_R = 0.543 \times T_i - T_C$$

$$T_F = 0.457 \times T_i + T_C$$

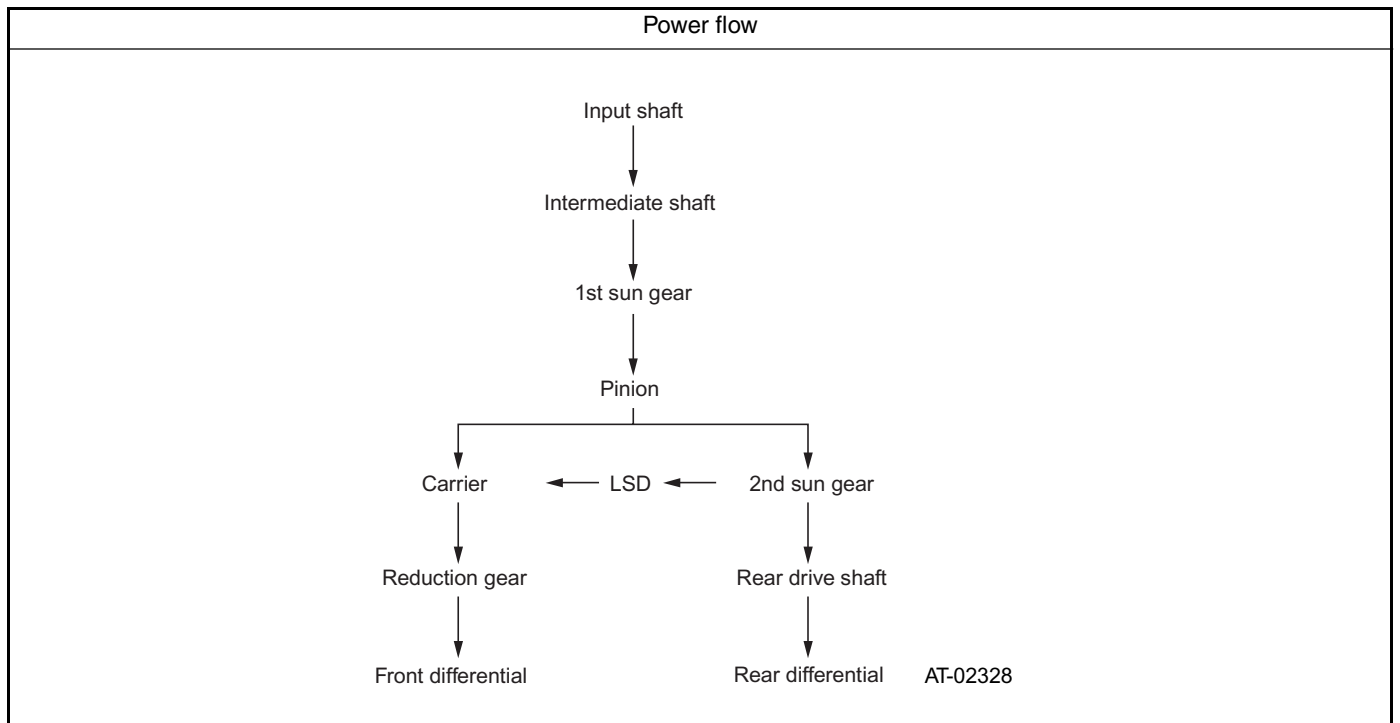

AWD TRANSFER SYSTEM

AUTOMATIC TRANSMISSION

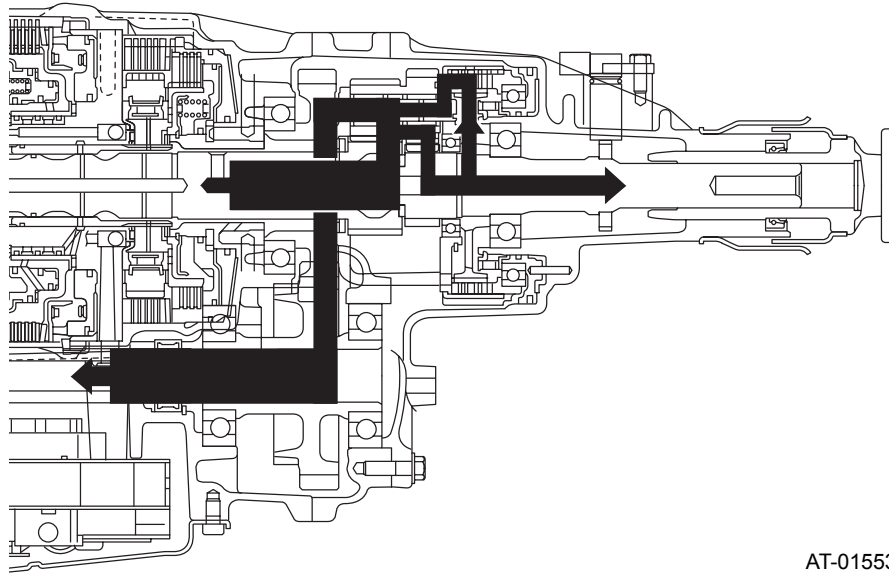

AT-01553

<Calculation of front and rear wheel torques>

If the frictional resistance resulting from meshing of the planetary gears and sliding of rotational components are ignored, the torques distributed to the front and rear wheels are expressed by the following equations:

$$T_R = [(Z_{P1} \times Z_{S2}) \div (Z_{S1} \times Z_{P2})] \times T_i$$

$$T_F = [1 - (Z_{P1} \times Z_{S2}) \div (Z_{S1} \times Z_{P2})] \times T_i$$

where

Z_{P1} : Number of teeth of 1st planetary gear

Z_{P2} : Number of teeth of 2nd planetary gear

Z_{S1} : Number of teeth of 1st sun gear

Z_{S2} : Number of teeth of 2nd sun gear

T_i : Input torque

If the number of teeth in each component is the same as that assumed in the equations on the previous page, the following ratios are the calculation results of the equations shown above.

$$T_R = 0.543 \times T_i$$

$$T_F = 0.457 \times T_i$$

As a result, the front-rear torque distribution ratio of the compound planetary gear set without an adjustment by the multi-plate clutch is 45.7 : 54.3.

C: CONSTRUCTION

1. CENTER DIFFERENTIAL ASSEMBLY

The center differential is a compound planetary gear set without internally-toothed gears. Input torque is transmitted to the 1st sun gear of the center differential, and from the 1st sun gear the torque is distributed through the 1st pinion to the carrier (output element of front wheel side), and to the 2nd sun gear (output element of rear wheel side) at a certain ratio.

The compound planetary gears use helical gears for quiet operation and strength. The four pinions are arranged to ensure the best motion balance during operation.

AWD TRANSFER SYSTEM

AUTOMATIC TRANSMISSION

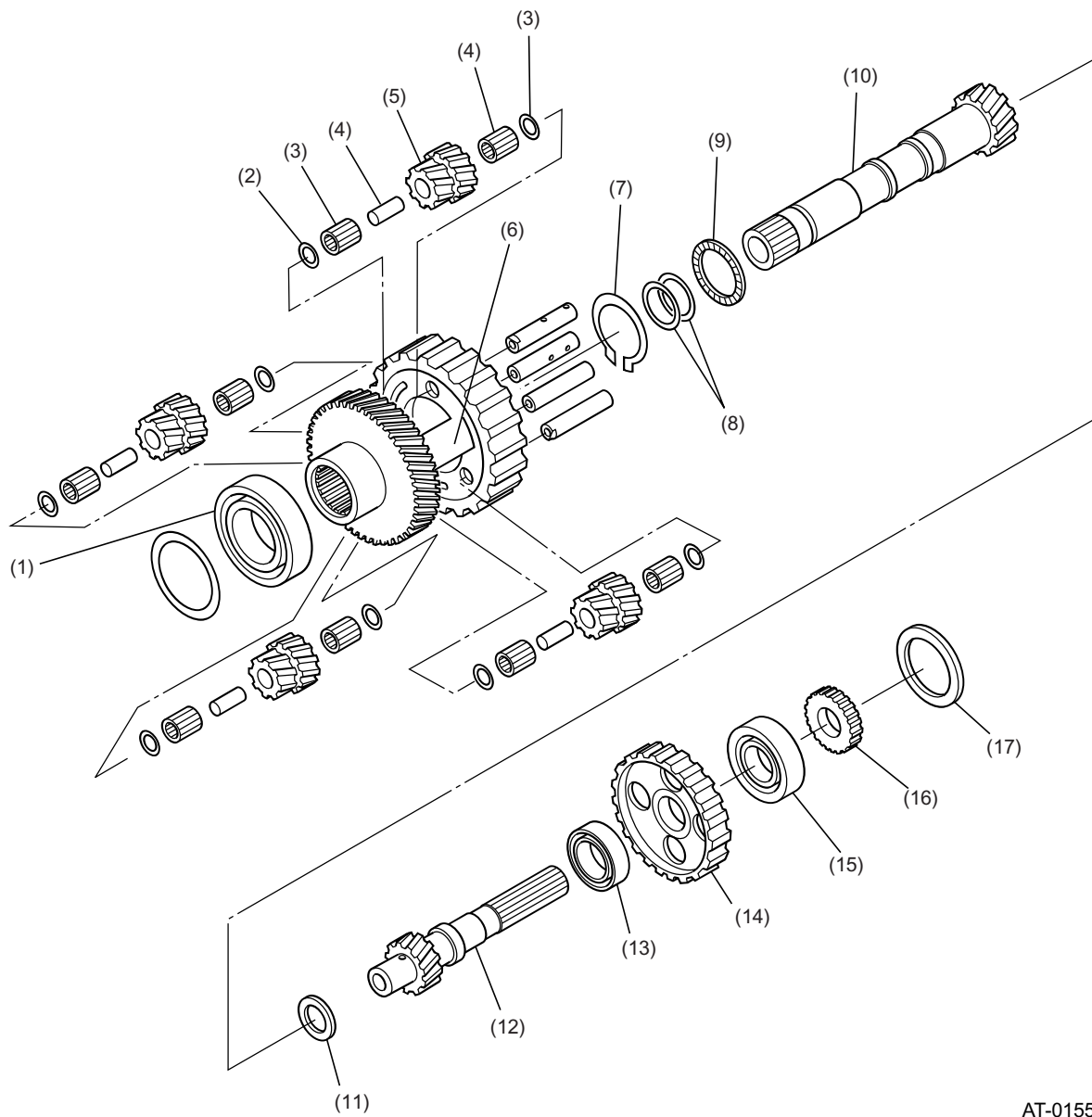

AT-01554

- | | | |
|--------------------|---------------------------|-----------------------------|
| (1) Ball bearing | (7) Snap ring | (13) Ball bearing |
| (2) Washer | (8) Seal ring | (14) Multi-plate clutch hub |
| (3) Needle bearing | (9) Thrust needle bearing | (15) Ball bearing |
| (4) Collar | (10) Intermediate shaft | (16) Revolution gear |
| (5) Pinion gear | (11) Thrust washer | (17) Rear drive shaft shim |
| (6) Carrier | (12) Rear drive shaft | |

2. MULTI-PLATE CLUTCH (LSD)

The transfer's differential action limiting device (LSD) consists of a piston that press together the wet multi-plate clutch to generate differential action limiting force.

The rear drive shaft has drilled oil passages for lubrication of multi-plate clutch and extension bushing and ball bearing in it.

AWD TRANSFER SYSTEM

AUTOMATIC TRANSMISSION

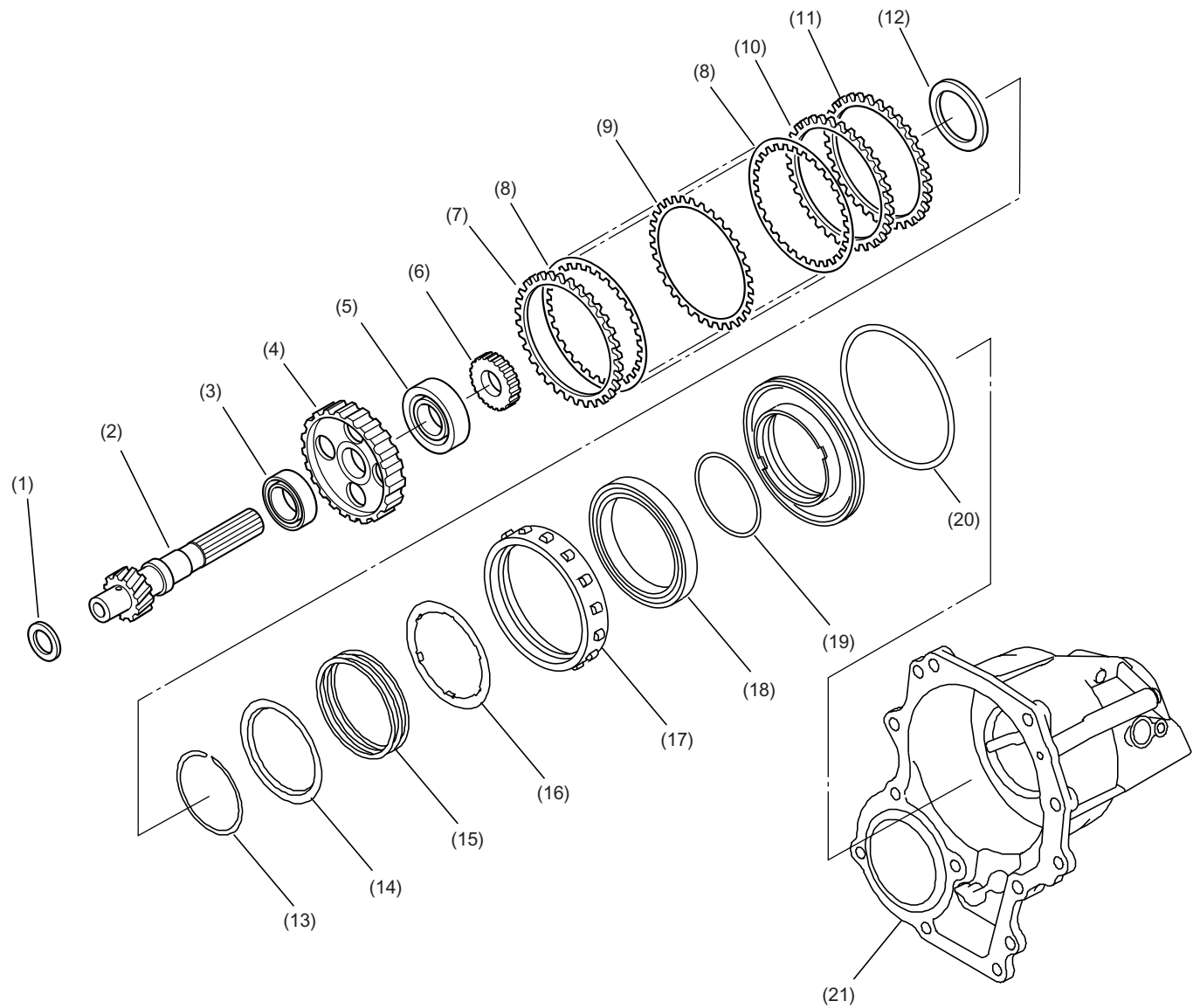

AT-01716

- | | | |
|----------------------------|-----------------------------|-----------------------------|
| (1) Thrust washer | (8) Drive plate | (15) Return spring |
| (2) Rear drive shaft | (9) Driven plate (thin) | (16) Clutch spring retainer |
| (3) Ball bearing | (10) Driven plate (thick) | (17) Pressure plate |
| (4) Multi-plate clutch hub | (11) Adjust plate | (18) Ball bearing |
| (5) Ball bearing | (12) Rear drive shaft shim | (19) O-ring |
| (6) Revolution gear | (13) Snap ring | (20) C-ring |
| (7) Driven plate (thick) | (14) Clutch spring retainer | (21) Extension case |

3. TRANSFER HYDRAULIC PRESSURE CONTROL UNIT

The transfer hydraulic control unit consists of the transfer linear solenoid installed in the transmission hydraulic control valve assembly and the transmission hydraulic control valve.

The transfer linear solenoid controls the transfer pilot pressure in accordance with the differential action limiting force determined by the TCM based on driving and road conditions, and the transfer hydraulic control valve regulates the line pressure into transfer pressure in accordance with the transfer pilot pressure.

The transfer pressure is sent through the passages formed in the transmission case and extension case to the clutch piston chamber.

ELECTRO-HYDRAULIC CONTROL SYSTEM

AUTOMATIC TRANSMISSION

14. Electro-hydraulic Control System

A: DESCRIPTION

The electro-hydraulic control system for the transmission and transfer consists of various sensors and switches, TCM, and the control valves including solenoid valves. The system controls the automatic transmission operation, including gear shifting, lockup clutch operation, line pressure, pilot pressure, and gear-shift timing. It also controls the operation of the transfer clutch. The TCM determines vehicle operating conditions from various input signals and controls a total of eight solenoids (front brake solenoid, low coast brake solenoid, input clutch solenoid, high and low reverse clutch solenoid, direct clutch solenoid, lockup solenoid, line pressure solenoid, and transfer solenoid) by sending appropriate signals to them.

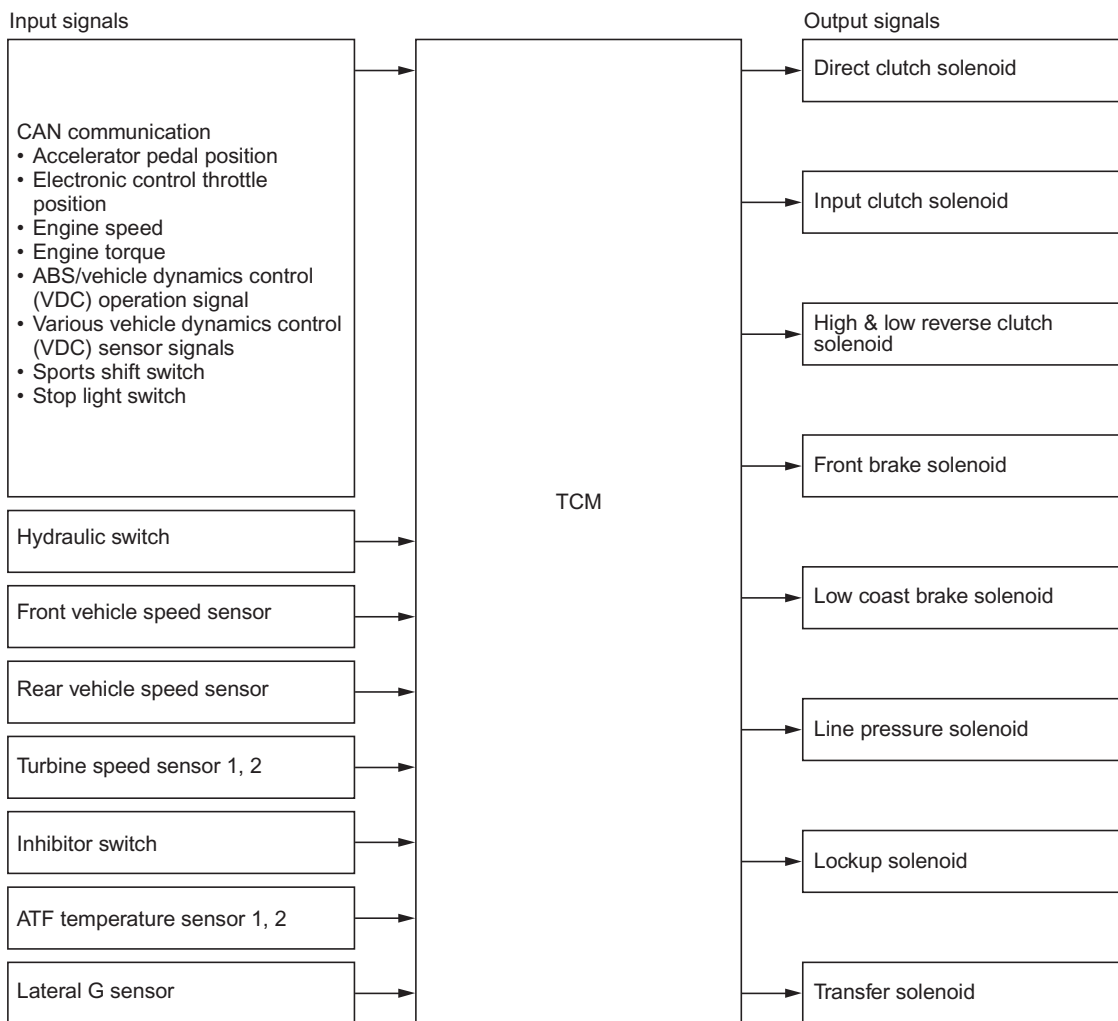

AT-02246

ELECTRO-HYDRAULIC CONTROL SYSTEM

AUTOMATIC TRANSMISSION

B: CONTROL ITEMS

Control items		Description of control
Transmission hydraulic control	Shifting control	Shift pattern selection Upshift points and downshift points are set for each range and shift pattern selected by switch operation, according to throttle position and vehicle speed. <Ref. to 5AT section, Transmission Control Module (TCM).>
		Control of linear solenoid for each shift clutch The linear solenoid for each shift clutch is directly controlled in accordance with the target gear speed. Supported by the learning control and real time feedback functions, control values are corrected any time when necessary to improve shift quality and eliminate errors due to aging.
		Engine braking control In manual mode, the low coast brake ON-OFF solenoid is controlled to make engine braking available in 1st and 2nd speeds.
	Lockup control	Base lockup control Lockup engagement and disengagement points are set for each range and shift pattern selected by switch operation, according to throttle position and vehicle speed, and the lockup solenoid is controlled in accordance with these points to engage or disengage the lockup clutch inside the torque converter.
		Smooth control When the lockup clutch is engaged, the pressure is gradually changed to ensure a smooth engagement.
	Line pressure control	Ordinary control Line pressure is properly regulated according to information such as the electronic control throttle position, engine torque value, engine speed, vehicle speed, and range position.
		Control during engine braking Line pressure is regulated in accordance with the vehicle speed while engine braking is used.
		Line pressure control in during shifting Line pressure is regulated to the necessary value during gear shifting.
		Line pressure control when ATF temperature is low Hydraulic pressure is controlled to a higher value than normal when the ATF temperature is low.
	AWD center differential control	Ordinary transfer control Multi-plate clutch (LSD) pressure is regulated according to the torque input to the transfer and the driving condition.
Start control LSD pressure is regulated according to the torque input to the transfer. Compared to normal control, the control pressure is raised to prevent slip.		
Turning control When the front and rear wheel speed ratio is less than the set value for a vehicle speed, the LSD pressure is decreased.		
Slip control When a front or rear wheel starts slipping, the LSD pressure is increased.		
Control while ABS/vehicle dynamics control (VDC) in operation When ABS/vehicle dynamics control (VDC) operation signal is received, the LSD pressure is adjusted to the set level.		
Base brake control When the brake switch is ON and throttle valve is fully closed, the LSD pressure is lowered.		

ELECTRO-HYDRAULIC CONTROL SYSTEM

AUTOMATIC TRANSMISSION

C: CONTROL OF HYDRAULIC PRESSURE FOR SHIFTS

- Control of linear solenoid for each shift clutch

The linear solenoid for each shift clutch is directly controlled by means of electrical current in accordance with the target gear speed. The control current value is corrected any time when necessary by the learning control and real time feedback functions to improve shift quality and eliminate errors due to aging.

- Engine braking control

In manual mode, the low coast brake solenoid is controlled to make engine braking available in 1st and 2nd speeds.

D: LOCKUP CONTROL

- By engaging the lockup clutch in the torque converter, the slip in the torque converter is eliminated and power is transmitted more effectively.

- Based on signals from the TCM, the lockup solenoid is controlled in order to let the lockup control valve operate and adjust apply pressure/release pressure, to consequently vary the lockup clutch engagement force.

Lockup operation conditions

Select lever	Gear position	Full lockup
D range	3	Δ
	4	Δ
	5	○
Manual mode	3	○
	4	○
	5	○

Δ: When the hill climbing mode is selected according to driving conditions, or when high ATF temperature is detected.

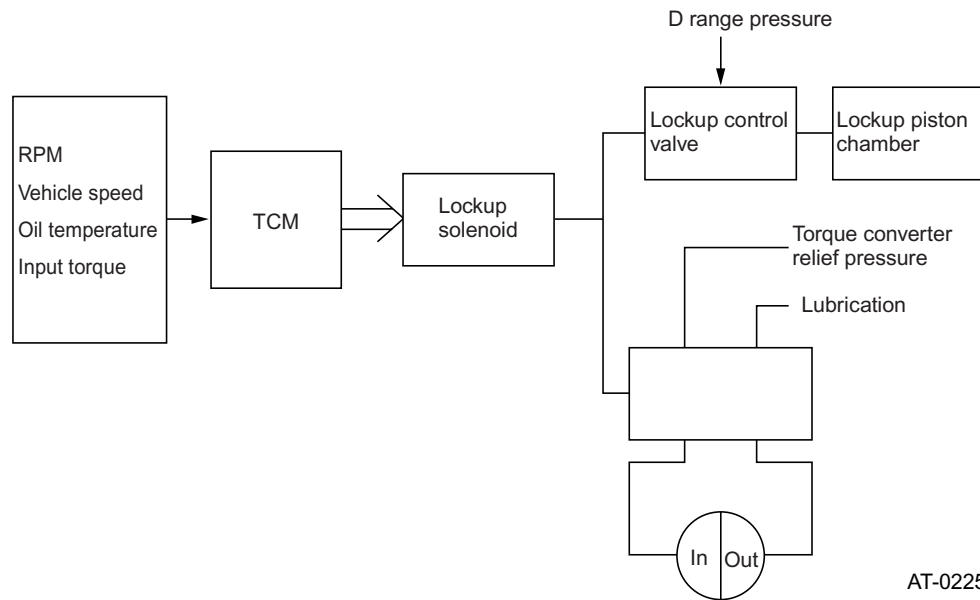

1. LOCKUP DISENGAGED STATE

When lockup is disengaged, the lockup solenoid causes the lockup control valve to open the clutch disengaging port, and the lockup operating pressure is added to the disengaging circuit. In the meantime, the lockup clutch control valve opens the lockup clutch engaging port and allows the hydraulic fluid in the circuit to flow to the ATF cooler, thus lowering the pressure in the engaging circuit. As a result, the lockup clutch is disengaged due to difference in pressure between both circuits. This operation is performed in all speed gears.

2. LOCKUP ENGAGED STATE

When lockup is engaged, the lockup solenoid puts the lockup control valve in the lockup state and builds up lockup operating pressure.

The lockup control valve then opens the clutch engaging circuit's port that communicates to the torque converter's impeller chamber, allowing high pressure fluid to flow to the lockup clutch and the clutch is engaged.

This operation is performed in all speed gears, and the lockup engages in response to the vehicle speed when the 5th gear is selected in the D range.

3. SMOOTH LOCKUP CONTROL

During the transition period from the lockup (disengaged) state to the lockup engaged state, the TCM controls the current output to the lockup solenoid. By changing the current output to the lockup solenoid and gradually raising the lockup clutch pressure, the lockup clutch piston is first put in a partially engaged state and its pressure is gradually increased to reduce shock.

ELECTRO-HYDRAULIC CONTROL SYSTEM

AUTOMATIC TRANSMISSION

E: LINE PRESSURE CONTROL

When torque signals corresponding to the engine drive power is sent from the ECM to the TCM, the TCM controls the line pressure solenoid. Using the line pressure solenoid pressure as a signal pressure, the pressure regulator valve is controlled, and the ATF discharged from the oil pump is regulated to an optimum level corresponding to the vehicle's running conditions.

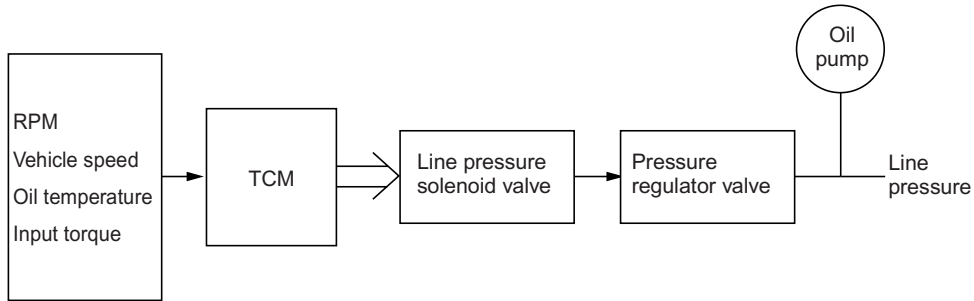

AT-02256

1. LINE PRESSURE CONTROL IN NORMAL CONDITIONS

The line pressure which engages shift clutches to create 1st to 4th speeds, is regulated to a pressure required at each clutch according to the input torque.

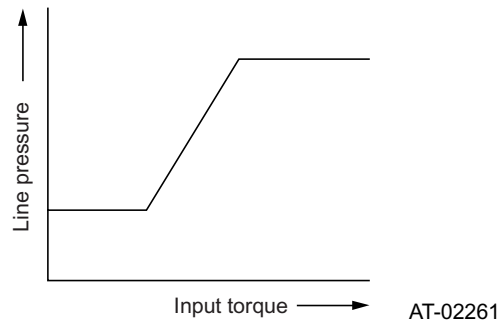

AT-02261

2. LINE-PRESSURE CONTROL DURING ENGINE BRAKING IN SPORTS MODE

When engine braking is used to let the transmission downshift, the line pressure is regulated in accordance with the vehicle speed.

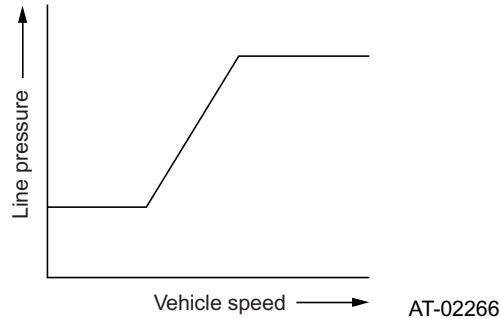

3. LINE-PRESSURE CONTROL DURING SHIFTING

During shifting, the line pressure is set to a level suitable for the input speed, input torque and the difference between the required and current gear speed.

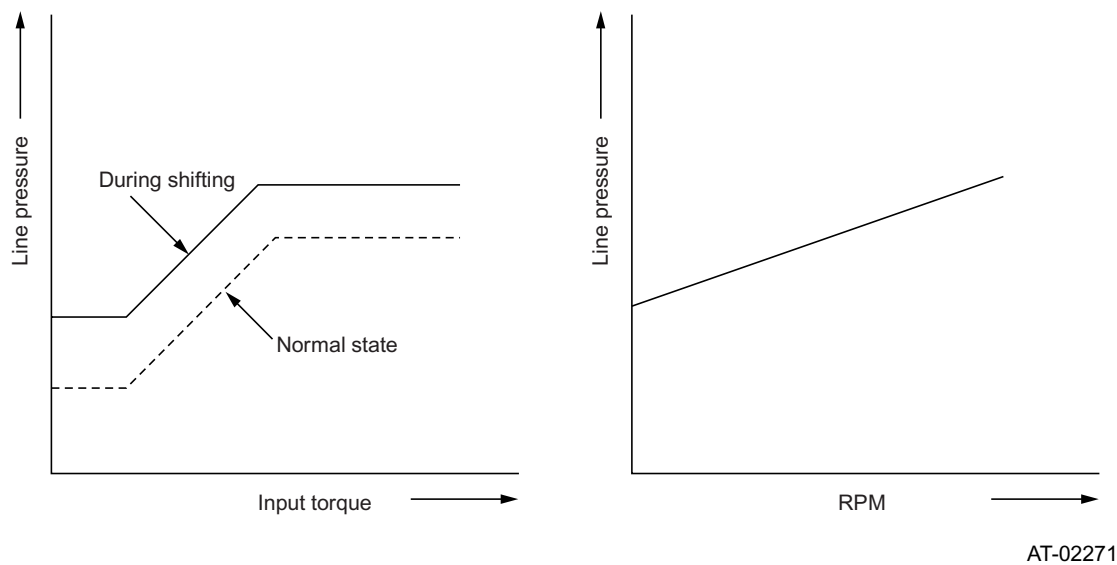

ELECTRO-HYDRAULIC CONTROL SYSTEM

AUTOMATIC TRANSMISSION

4. LINE PRESSURE CONTROL WHEN ATF TEMPERATURE IS LOW

When the ATF temperature is low, the line pressure control characteristics is set higher than normal so that the clutches and brakes will operate at an earlier stage.

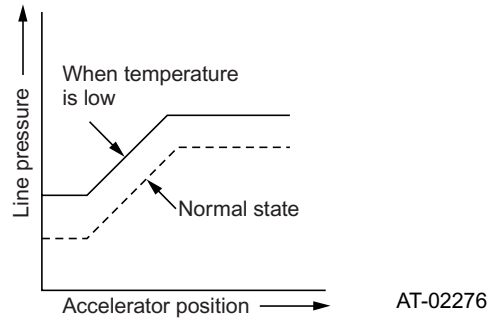

15.Sensor Systems

A: REAR VEHICLE SPEED SENSOR

This vehicle speed sensor is a Hall element type sensor and is externally mounted on the extension case. It detects the rear wheel speed in terms of the peripheral speed of the rear drive shaft and sends pulse signals (22 pulses per rotation) to the TCM.

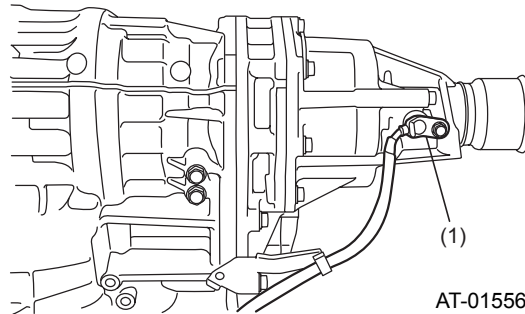

(1) Rear vehicle speed sensor

B: FRONT VEHICLE SPEED SENSOR

This vehicle speed sensor is a Hall element type sensor and is mounted on the inside of the transmission case. It detects the drive pinion shaft speed and sends pulse signals (16 pulses per rotation) to the TCM.

Signals from the front and rear vehicle speed sensors are used to calculate controlling vehicle speed, which is in turn used for gear shift control.

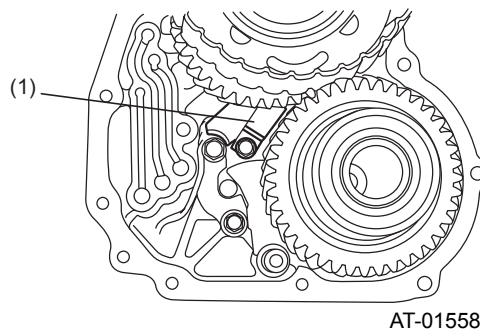

(1) Front vehicle speed sensor

SENSOR SYSTEMS

AUTOMATIC TRANSMISSION

C: ATF TEMPERATURE SENSOR 1, 2

These temperature sensors are thermistors and each of them is mounted on the control valve body. ATF temperature sensor 1 detects the ATF temperature in the oil pan, and ATF temperature sensor 2 detects the ATF temperature at the torque converter outlet; each sensor outputs electrical resistance signals.

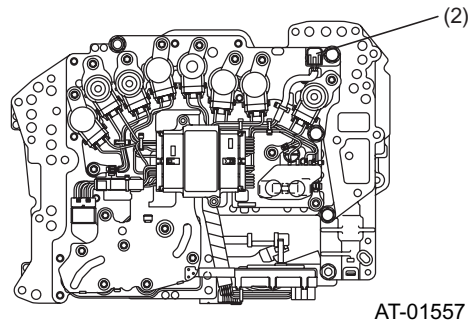
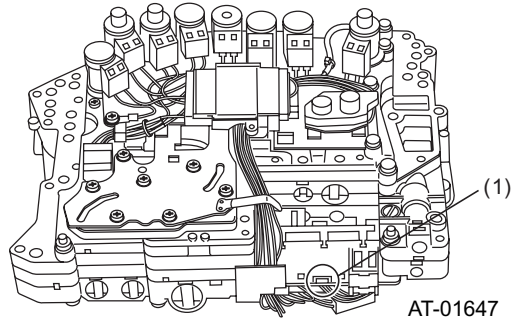

(1) ATF temperature sensor 1

(2) ATF temperature sensor 2

D: TURBINE SPEED SENSOR 1, 2

Wheel speed sensors are hall element type sensors. Turbine speed sensor 1 detects the speed of the front sun gear, and turbine sensor 2 detects the speed of the front carrier. Each sensor sends pulse signals (60 pulses per rotation) to the TCM. From these two speed values, the TCM calculates the turbine speed and uses it for shifting control.

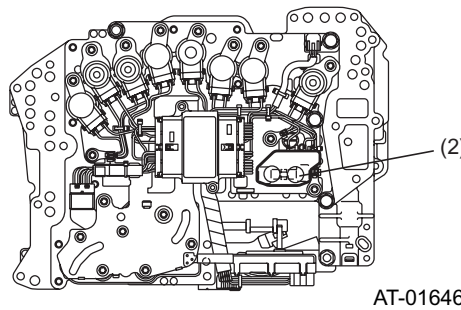
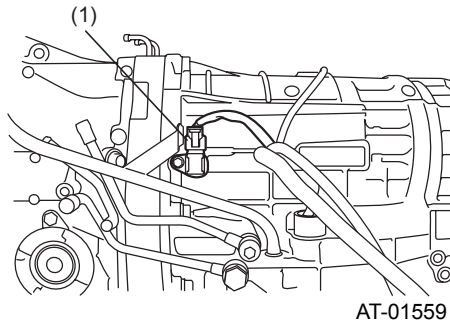

(1) Turbine speed sensor 1

(2) Turbine speed sensor 2

SENSOR SYSTEMS

AUTOMATIC TRANSMISSION

E: INHIBITOR SWITCH

The inhibitor switch is installed in the control valve and is connected to the TCM with 4 signal lines. The TCM uses this signal to detect range positions and to perform various controls. Relation between signals from the 4 lines (INH1 to 4) and range positions are as shown below:

	INH1	INH2	INH3	INH4
P				
R	○			○
N	○	○		
D	○	○	○	○

When the range position is detected as P or N as shown above, the TCM sends a signal (PN signal) allowing operation of the starter. On the other hand, in R or D range, starter operation is inhibited to ensure safety.

Additionally, when the range position is detected as R, the TCM turns the backup light relay output to ON and lets the backup lights illuminate.

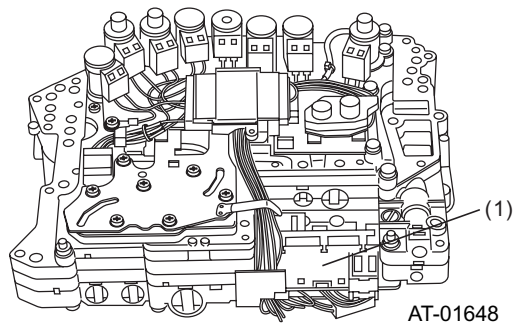

(1) Inhibitor switch

F: LINE PRESSURE SOLENOID

The line pressure solenoid is mounted on the control valve and is directly controlled by electrical current instructions from the TCM. This controls the pressure modifier valve and accumulator control valve A to adjust the line pressure to an optimum pressure level suitable for operating conditions.

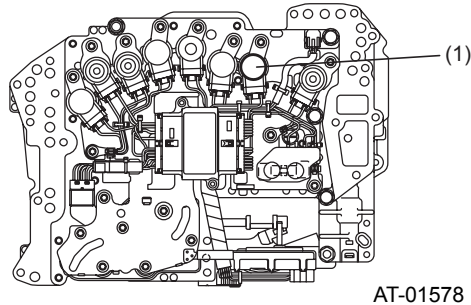

(1) Line pressure solenoid

G: LOCKUP SOLENOID

The lockup solenoid is mounted on the control valve and is directly controlled by electrical current instructions from the TCM. It then controls the lockup control valve to provide smooth engagement and disengagement. It also enables stable slip lockup control while supported by learning control and real time feedback functions.

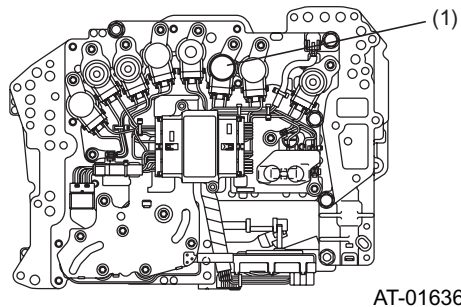

(1) Lockup solenoid

SENSOR SYSTEMS

AUTOMATIC TRANSMISSION

H: FRONT BRAKE SOLENOID

The front brake solenoid is mounted on the control valve and is directly controlled by electrical current instructions from the TCM. This solenoid is activated when the front brake is to be engaged. Control values are corrected any time when necessary by the learning control and real time feedback functions to improve shift quality and eliminate errors due to aging.

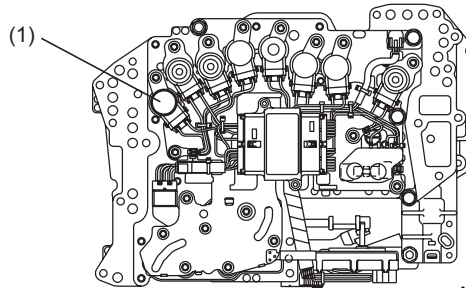

AT-01579

(1) Front brake solenoid

I: INPUT CLUTCH SOLENOID

The input clutch solenoid is mounted on the control valve and is directly controlled by electrical current instructions from the TCM. This solenoid is activated when the input clutch is to be engaged. Control values are corrected any time when necessary by the learning control and real time feedback functions to improve shift quality and eliminate errors due to aging.

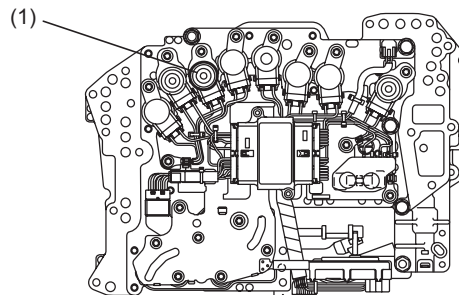

AT-01617

(1) Input clutch solenoid

J: DIRECT CLUTCH SOLENOID

The direct clutch solenoid is mounted on the control valve and is directly controlled by electrical current instructions from the TCM. This solenoid is activated when the direct clutch is to be engaged. Control values are corrected any time when necessary by the learning control and real time feedback functions to improve shift quality and eliminate errors due to aging.

The direct clutch pressure can be switched to two range pressures with the direct clutch piston switch valve.

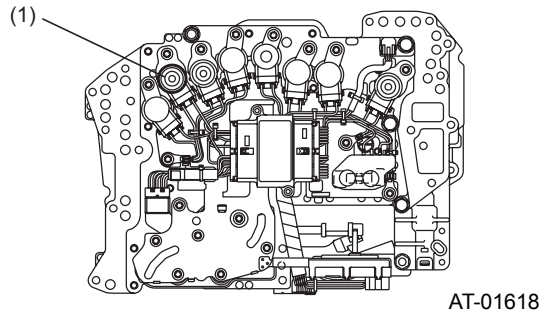

(1) Direct clutch solenoid

K: HIGH AND LOW REVERSE CLUTCH SOLENOID

The high and low reverse clutch solenoid is mounted on the control valve and is directly controlled by electrical current instructions from the TCM. This solenoid is activated when the high and low reverse clutch is to be engaged. Control values are corrected any time when necessary by the learning control and real time feedback functions to improve shift quality and eliminate errors due to aging.

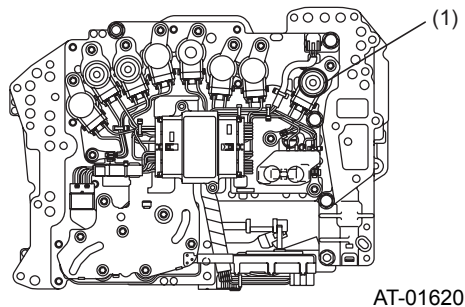

(1) High and low reverse clutch solenoid

SENSOR SYSTEMS

AUTOMATIC TRANSMISSION

L: LOW COAST BRAKE SOLENOID

The low coast brake solenoid is mounted on the control valve and is directly controlled by ON/OFF instructions from the TCM. This solenoid is activated when the low coast brake is to be engaged during usage of engine braking in 1st or 2nd speed in manual mode.

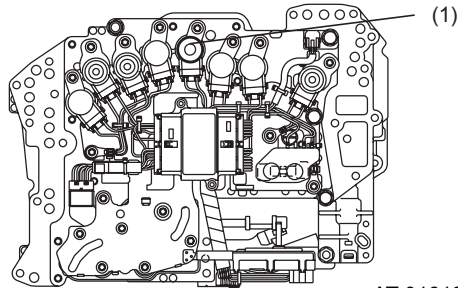

AT-01619

(1) Low coast brake solenoid

M: TRANSFER SOLENOID

The transfer solenoid is mounted on the control valve and is directly controlled by electrical current instructions from the TCM. This ensures optimum AWD control in accordance with the varying road conditions by engaging/releasing the transfer clutch.

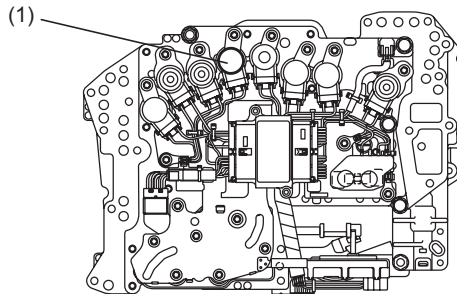

AT-01615

(1) Transfer solenoid

N: MEMORY BOX

The memory box is mounted on the control valve and stores hydraulic correction values and learned values for the initial shifting pressures for each solenoid, based on its hydraulic characteristics at the time delivered from the factory. The TCM acquires data from this memory box and performs correction based on these data to control each solenoid. This ensures high quality shifting from the time the vehicle was delivered from the factory.

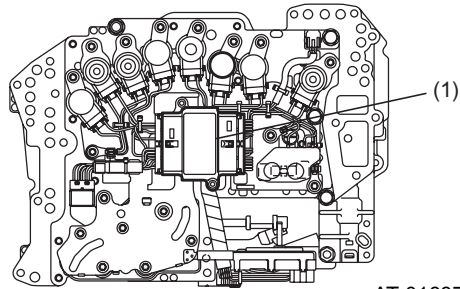

AT-01637

(1) Memory box

TRANSMISSION CONTROL MODULE (TCM)

AUTOMATIC TRANSMISSION

16. Transmission Control Module (TCM)

The TCM receives various sensor signals and determines the running conditions of the vehicle. It then sends control signals to each solenoid according to the preset gearshift characteristic data, lockup operation data, and transfer clutch torque data.

A: CONTROL SYSTEM

Control items		Input signals
Shifting control	Ordinary shift control	Accelerator pedal position signal Engine torque signal Engine speed Front vehicle speed signal Rear vehicle speed signal Turbine sensor 1, 2 signal Range signal
	Engine cooperative control	Front vehicle speed signal Rear vehicle speed signal Various engine information
	ABS cooperative control	Front vehicle speed signal Rear vehicle speed signal ABS operating signal Brake switch signal
	Control at high oil temperatures	ATF temperature sensor 1 signal ATF temperature sensor 2 signal
	Control when ATF or coolant temperature is low	ATF temperature sensor 1 signal ATF temperature sensor 2 signal Coolant temperature information
	Control when cruise control in operation	Cruise control switch signal Cruise control set signal

TRANSMISSION CONTROL MODULE (TCM)

AUTOMATIC TRANSMISSION

Control items		Input signals
Shift pattern selection control	Adaptive control	Shift pattern automatic switching control
		Accelerator pedal position signal Engine speed Engine torque signal Front vehicle speed signal Rear vehicle speed signal Range signal Lateral G sensor signal Sports mode switch signal
		Accelerator pedal quick depressing control
		Accelerator pedal position signal Front vehicle speed signal Rear vehicle speed signal Range signal
		Accelerator pedal quick return control
		Accelerator pedal position signal Front vehicle speed signal Rear vehicle speed signal Range signal Sports mode switch signal
	Braking control	Accelerator pedal position signal Front vehicle speed signal Rear vehicle speed signal Range signal Sports mode switch signal Brake switch signal
	Control during cornering	Accelerator pedal position signal Front vehicle speed signal Rear vehicle speed signal Range signal Sports mode switch signal Lateral G sensor signal
	Sports mode control	Accelerator pedal position signal Engine torque signal Front vehicle speed signal Rear vehicle speed signal Range signal Sports mode switch signal
	Manual mode control	Engine speed Front vehicle speed signal Rear vehicle speed signal Range signal Sports mode switch signal Upshift switch signal Downshift switch signal ATF temperature sensor 1 signal ATF temperature sensor 2 signal
Shift pattern selection control	2nd hold control (in Manual mode)	Front vehicle speed signal Rear vehicle speed signal Range signal Sports mode switch signal Upshift switch signal Downshift switch signal
	Steering sports shift control	Engine speed Front vehicle speed signal Rear vehicle speed signal Range signal Sports mode switch signal Upshift switch signal Downshift switch signal ATF temperature sensor 1 signal ATF temperature sensor 2 signal Lateral G sensor signal

TRANSMISSION CONTROL MODULE (TCM)

AUTOMATIC TRANSMISSION

Control items		Input signals
Lockup control	Ordinary lockup control	Accelerator pedal position signal Rear vehicle speed signal Front vehicle speed signal Engine speed Range signal ATF temperature signal
	Slip lockup control	Front vehicle speed signal Rear vehicle speed signal Range signal Engine speed Turbine speed signal ATF temperature signal
Oil pressure control	Ordinary pressure control	Accelerator pedal position signal Rear vehicle speed signal Front vehicle speed signal Engine speed Range signal ATF temperature signal
	Shifting control	Accelerator pedal position signal Rear vehicle speed signal Front vehicle speed signal Engine speed Turbine speed signal Range signal ATF temperature signal
AWD center differential	Ordinary transfer control	Throttle position signal Rear vehicle speed signal Front vehicle speed signal Inhibitor switch ATF temperature signal Turbine speed signal Engine torque signal
	Slip detection control	Accelerator pedal position signal Rear vehicle speed signal Front vehicle speed signal Brake switch
	Steering control	Accelerator pedal position signal Rear vehicle speed signal Front vehicle speed signal Steering angle signal
	Control while ABS/vehicle dynamic control (VDC) in operation	ABS operating signal Vehicle dynamic control (VDC) operating signal Rear vehicle speed signal Front vehicle speed signal Brake switch
	Braking control	Accelerator pedal position signal Front vehicle speed signal Brake switch
	Start control	Engine torque signal Rear vehicle speed signal Front vehicle speed signal Turbine speed signal

TRANSMISSION CONTROL MODULE (TCM)

AUTOMATIC TRANSMISSION

B: SCHEMATIC DIAGRAM

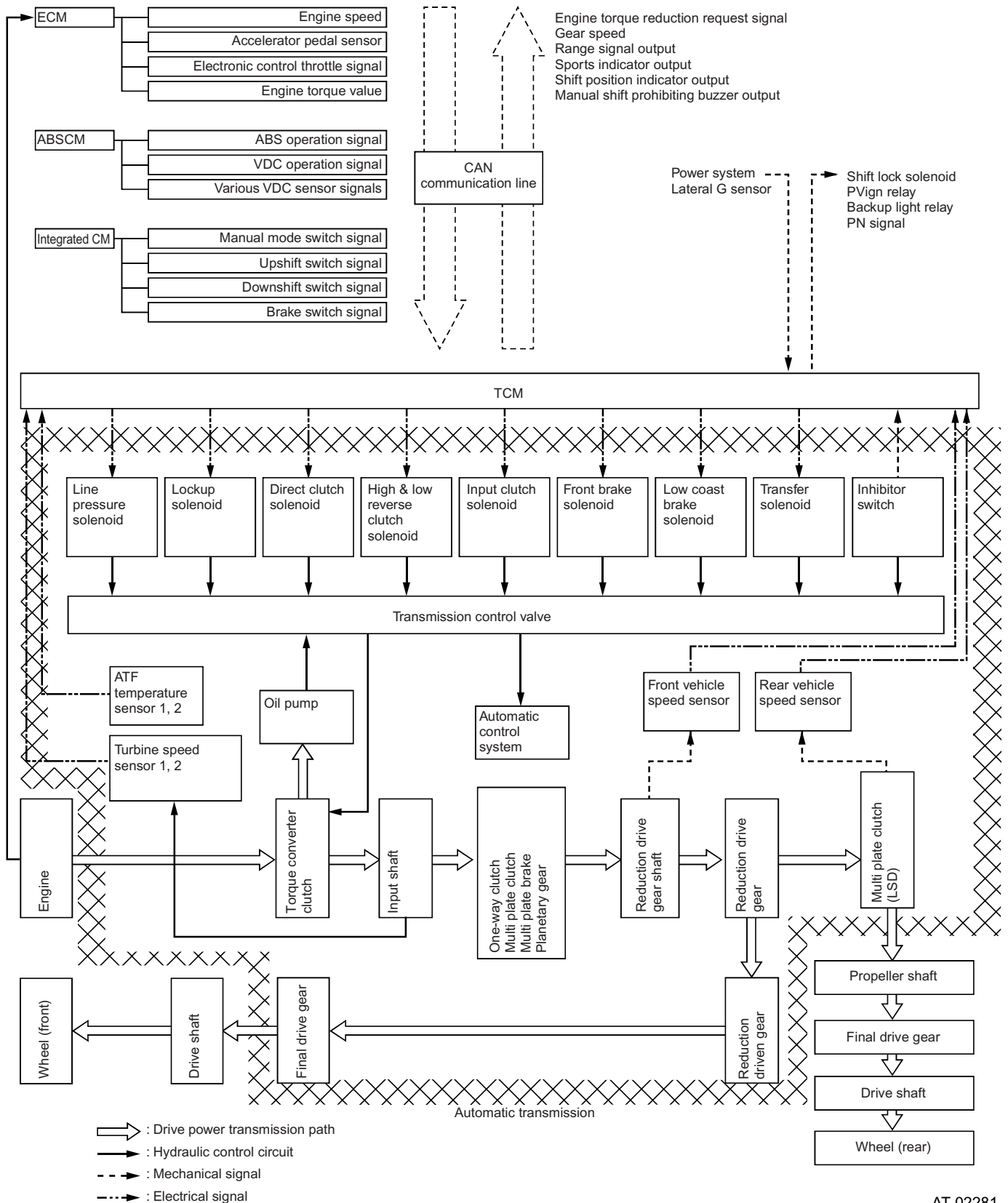

AT-02281

TRANSMISSION CONTROL MODULE (TCM)

AUTOMATIC TRANSMISSION

C: SHIFTING CONTROL

1. ORDINARY SHIFT CONTROL

The TCM controls each solenoid based on input signal information such as inhibitor switch signals, vehicle speed signals and accelerator pedal position signals, to automatically select the optimum gear position from the shifting map.

2. ENGINE COOPERATIVE CONTROL

During shifting, the TCM outputs a torque-down requirement signal, and the ECM receives this to retard the ignition timing of each cylinder to temporarily decrease the output torque from the engine. Simultaneously with this control, the TCM constantly monitors the shift sequence through vehicle speed sensors and the turbine speed sensor to perform feedback control and optimize gear shifts. Because of this control, a smooth and comfortable gear shifting is ensured under all conditions.

3. ABS COOPERATIVE CONTROL

When the ABS is operating, the optimum gear speed for the vehicle speed is selected by cooperative operation with the ABSCM to prevent degrading the operation of the ABS.

4. CONTROL AT HIGH OIL TEMPERATURES

If the ATF temperature becomes extremely high, shifting control is performed by automatically switching to a shifting map that is less likely to cause temperature rise.

5. CONTROL WHEN ATF OR ENGINE COOLANT TEMPERATURE IS LOW

When the ATF temperature or engine coolant temperature is extremely low at engine start, etc., shifting control is performed by automatically switching to a shifting map that causes temperature rise easier.

6. CONTROL WHEN CRUISE CONTROL IN OPERATION

When the cruise control is operating, shifting control is performed by automatically switching to a shifting map that is suitable for cruise control.

TRANSMISSION CONTROL MODULE (TCM)

AUTOMATIC TRANSMISSION

MEMO

TRANSMISSION CONTROL MODULE (TCM)

AUTOMATIC TRANSMISSION

D: SHIFT PATTERN SELECTION

1. ADAPTIVE CONTROL

This control is performed to improve the drivability of the vehicle by optimizing gear shifts in accordance with the driver's intention to accelerate or decelerate, and driving conditions such as hill climbing, winding road driving, etc.

- Shift pattern automatic switching control

This control enables selection of the optimum gear speed by automatically switching the shift pattern by estimating driver's intentions and driving conditions through sensor information such as driving resistance, engine speed, acceleration, vehicle speed, and also from calculated values.

Any of the three patterns NORMAL, SPORTS, and SLOPE are continuously and automatically selected under the following conditions.

D range

NORMAL↔SPORTS↔SLOPE

D range, in sports mode

SPORTS↔SLOPE

Normal pattern: covers a wide range from normal driving to high speed driving.

Sports pattern: a shift pattern suitable for driving conditions requiring deep accelerator pedal positions, such as winding road driving.

Slope pattern: this shift pattern controls upshifting to prevent too frequent gear shifting during climbing or descending hills. By combining braking control (in sports mode only) (explained later), automatic engine braking will be available when descending hills.

TRANSMISSION CONTROL MODULE (TCM)

AUTOMATIC TRANSMISSION

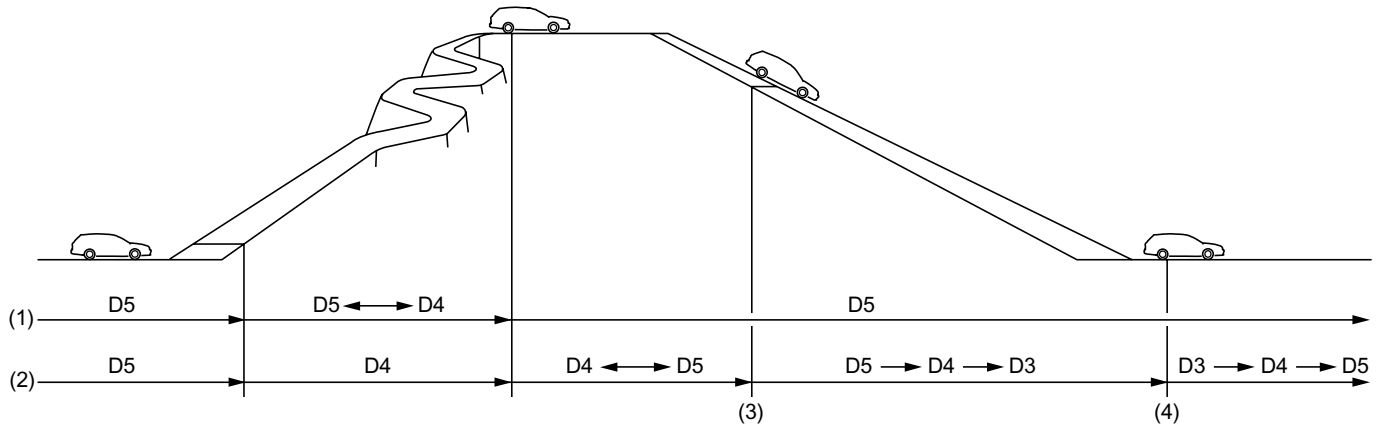

AT-01731

- (1) Without climb/descend control
- (2) With climb/descend control

- (3) Brake pedal ON
- (4) Re-acceleration

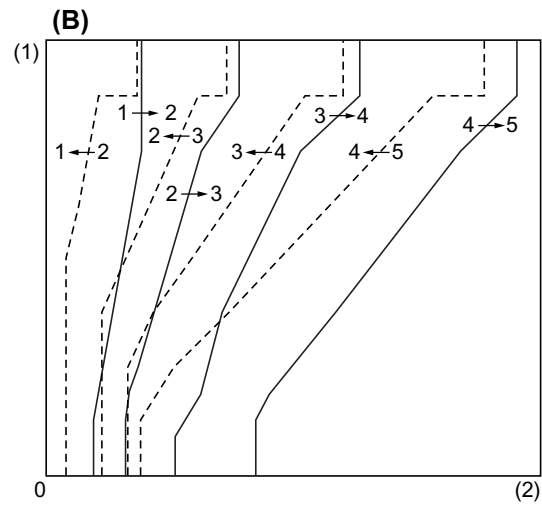
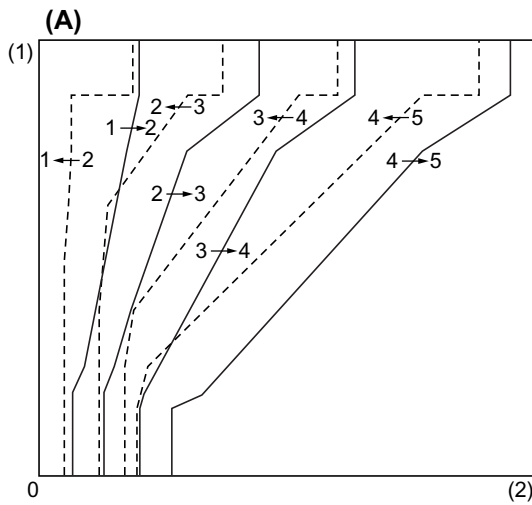

AT-01730

- (A)** Base pattern
- (1) Accelerator pedal position

- (B)** Grade control pattern
- (2) Vehicle speed

TRANSMISSION CONTROL MODULE (TCM)

AUTOMATIC TRANSMISSION

- Accelerator pedal quick depressing control

When the accelerator pedal is quickly depressed, the TCM interprets this as acceleration is required, and the transmission is downshifted earlier to obtain a greater drive force.

- Accelerator pedal quick return control

When the accelerator pedal is quickly released, the TCM interprets this as deceleration is required, and upshift is prohibited in order to hold the transmission in the current gear speed to prevent frequent shifting and to maintain engine braking effect (operates in sports mode only).

- Braking control

According to the braking force (deceleration) during braking, downshifts are hastened to ensure engine braking effect and obtain a larger driving power for accelerating after braking (operates in sports mode only).

- Control during cornering

When the system interprets that the vehicle is turning a corner by the lateral acceleration and the change rate in vehicle speed, it prevents unwanted upshifts to maintain a stable drive force and cornering performance.

2. SPORTS MODE CONTROL

When the shift lever is moved toward the manual gate side in D range, the SPORT light in the combination meter illuminates and the system enters the Sports mode. Gearshift timings are set at higher vehicle and engine speeds to make more use of low speed gears. The full lockup vehicle speed in 5th is also set higher than in the normal mode.

3. MANUAL MODE CONTROL

By operating the “+” or “-” switch on the select lever or steering wheel in D range with the sports mode switch ON (in sports mode), the system switches to manual mode. In this mode, operating the “+” switch causes upshifting while operating the “-” switch causes downshifting; manual shifting is enabled and the selected gear position is held while driving.

However, at certain vehicle speeds or ATF temperatures, the following inhibiting control is performed.

- Upshift inhibiting and auto downshift control

The gear upshifts each time the “+” switch is operated, however, when the vehicle speed is too low for the selected gear speed, the TCM inhibits further upshifting. If the vehicle speed becomes too slow for the current gear speed, a downshift will be made automatically to prevent engine stall. When the vehicle comes to a stop, the transmission will always be controlled to shift to 1st speed unless the vehicle was in manual 2nd hold control.

- Downshift inhibiting control

The gear downshifts each time the “-” switch is operated, however, when the vehicle speed is too low for the selected gear speed, the TCM inhibits further shifting. A manual shifting inhibiting buzzer will sound to warn the driver.

- Control when oil temperature is low

When the ATF temperature is low as in cases such as immediately after start in winter, upshifting to 5th is inhibited to quicken warm up.

- Engine over speed prevention control

If the engine speed exceeds the preset value during accelerating, the fuel supply is cut to prevent over-revving of the engine.

4. 2nd HOLD CONTROL (IN MANUAL MODE)

When the “+” switch is operated when the vehicle is in manual mode and not moving, the transmission shifts to 2nd speed enabling start in 2nd. This status is held unless the manual mode is canceled, or a speed other than 2nd is selected with the “-” switch. Also, the transmission is held in 2nd when the vehicle is stopped.

TRANSMISSION CONTROL MODULE (TCM)

AUTOMATIC TRANSMISSION

5. STEERING SPORTS SHIFT CONTROL

By operating the “+” or “-” switch on the steering wheel in D range during Normal mode, the system can be temporary switched to manual mode to perform manual shift operations. In this mode, the mode automatically returns to the previous mode when the next operation is not performed within a specified time or when the vehicle is put in the straight forward accelerating state.

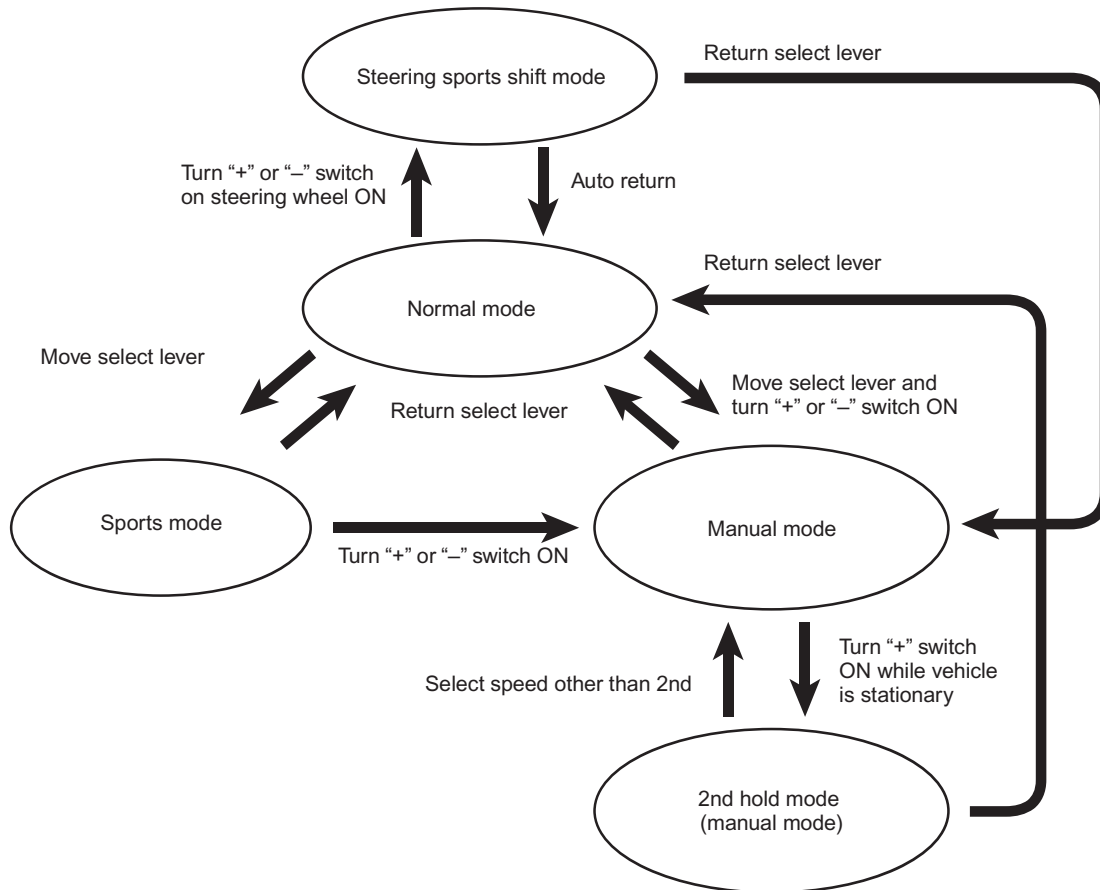

AT-02970

TRANSMISSION CONTROL MODULE (TCM)

AUTOMATIC TRANSMISSION

6. ILLUMINATION CONTROL OF VARIOUS INDICATORS

Illuminations of the various indicators on the combination meter are controlled in accordance with the shift pattern selection as shown below.

Status \ Indicator	D ●	SPORT	▲ ▼	1	Operation mode
Normal D range	D ●	SPORT	△ ▽	(extinguished)	Normal mode
In sports mode	D ●	SPORT	△ ▽	(extinguished)	Sports mode
Manual mode	D ○	SPORT	▲ ▼	1 — 5	Manual mode
When engine oil temperature is high and high engine speed is maintained	D ○	SPORT	△ ▽	—	Manual mode (at high oil temperature)
In steering sports shift	D ○	SPORT	▲ ▼	1 — 5	Semi sports shift mode
When engine oil temperature is high and high engine speed is maintained (upper row: first 2 seconds, lower row: thereafter)	D ●	SPORT	△ ▽	—	Normal mode (at high oil temperature)
	D ●	SPORT	△ ▽	(extinguished)	Normal mode (at high oil temperature)

NOTE:

- Indicators printed in solid black show their illuminated status.
- ATF TEMP indicator illuminates to inform of high ATF temperature.

AT-02882

TRANSMISSION CONTROL MODULE (TCM)

AUTOMATIC TRANSMISSION

E: CONTROL VALVE HYDRAULIC PRESSURE CORRECTION CONTROL AND LEARNING CONTROL

- Control valve hydraulic pressure correction control

During this control, the TCM acquires the hydraulic pressure correction data stored for each control valve in the memory box installed on the control valves, and then correctively controls the instruction current to each solenoid based on the data. This ensures stable shifting quality irrespective of variance between units.

- Learning control of shifting hydraulic pressures

To constantly ensure excellent shift quality regardless of the variance between friction material and aging, learning control of shifting hydraulic pressures is used.

Learning takes place for every normal shifting under certain conditions, and the learned values are saved in the flash ROM of the TCM. The values are not cleared even when the power is turned OFF (or the battery's negative terminal disconnected).

F: AWD CENTER DIFFERENTIAL CONTROL

1. CONTROL DESCRIPTION

Engagement of the multi-plate clutch (LSD) in the center differential is controlled according to the torque input to the transfer. It selects a map according to driving conditions and use it as the control basis.

2. NORMAL CONTROL

The input torque to the multi-plate clutch is calculated according to various factors such as engine torque signals, torque converter turbine speed and selected gear position. Based on the calculation result, the basic coupling force of the clutch is determined.

3. START CONTROL

When the vehicle speed is 0 km/h (0 MPH), the TCM increases the engaging force of the multi-plate clutch to a higher level compared to that of normal control.

This enables the vehicle to start smoothly without swerving even on a slippery road.

4. TURNING CONTROL

The TCM makes a correction such that the engagement force of the multi-plate clutch is reduced as the steering angle increases.

This function is performed to improve turning performance at certain vehicle speed range.

5. SLIP CONTROL

When front or rear wheels start slipping with the vehicle running slower than the predetermined speed, the TCM makes control to increase the differential action limiting torque.

This function maintains traction and improves driving stability.

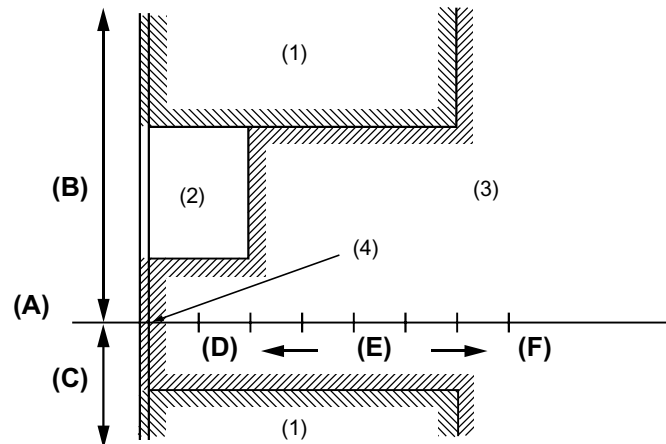

AT-00737

- | | |
|--------------------------------------|---------------------|
| (A) Front and rear wheel speed ratio | (1) Slip control |
| (B) Front wheel slip | (2) Turning control |
| (C) Rear wheel slip | (3) Normal control |
| (D) Low | (4) Start control |
| (E) Vehicle speed | |
| (F) High | |

6. ABS CONTROL

When the TCM receives an ABS operation signal from the ABSCM, it adjusts the differential action limiting torque to the predetermined level.

This function improves ABS control.

7. BASE BRAKE CONTROL

When the brake switch is ON and the throttle valve is fully closed, the TCM makes control to decrease the differential action limiting torque. The ABS control has priority over this control.

This function improves stability during braking.

G: RANGE LOCK CONTROL

This control prevents the select lever from being moved to the R position when the vehicle is running. Thus damage to components such as the reverse clutch is prevented.

When the specified speed is exceeded the TCM turns off the shift lock solenoid for the select lever. Therefore the range lock control works to inhibit operation from N range to R range, preventing the transmission from put into reverse.

ON-BOARD DIAGNOSTICS SYSTEM

AUTOMATIC TRANSMISSION

17. On-board Diagnostics System

A: FUNCTION

- The on-board diagnosis system detects and indicates a fault by generating a code corresponding to each fault location. The engine malfunction indicator light (SPORTS indicator light) on the combination meter indicates occurrence of a fault or abnormality.
- When the engine malfunction indicator light comes on as a result of detection of a fault by the TCM, the corresponding diagnostic trouble code (DTC) is stored in the TCM.
- On OBD-II available vehicles, it is necessary to connect the SUBARU Select Monitor (SSM) to the data link connector in order to check the DTC.
- To provide various functions and to facilitate fault isolation, a diagnosis system compatible with the SSM is used.
- The on-board diagnostics system detects the following electrical system faults or abnormalities in the system.

ATF temperature sensor 1, 2	Inhibitor switch
Turbine speed sensor 1, 2	CAN communication system
Front and rear wheel speed sensors	Interlock decision
Lockup solenoid (circuit, function)	1st engine brake abnormal
Line pressure solenoid (circuit)	Range lock solenoid (circuit)
Front brake solenoid (circuit, function)	PN signal output
Input clutch solenoid (circuit, function)	PVign power circuit (PVign relay)
High and low reverse clutch solenoid (circuit, function)	Backup light relay output circuit
Direct clutch solenoid (circuit, function)	TCM data communication abnormal
Low coast brake solenoid (circuit, function)	Lateral G sensor
Transfer solenoid (circuit)	Brake switch
Front brake hydraulic switch	Sports mode switch
Input clutch hydraulic switch	Engine speed signal
High and low reverse clutch hydraulic switch	1, 2, 3, 4, 5, R gear ratios
Direct clutch hydraulic switch	

If a fault is detected, the system tells the fault by causing the SPORTS indicator light to blink.

B: OPERATION OF SPORTS INDICATOR LIGHT

On starting the engine, the SPORTS indicator light illuminates for bulb check and then goes out as shown in the Normal diagram below. If any problem exists, the light continues flashing as shown in the Abnormal diagram below.

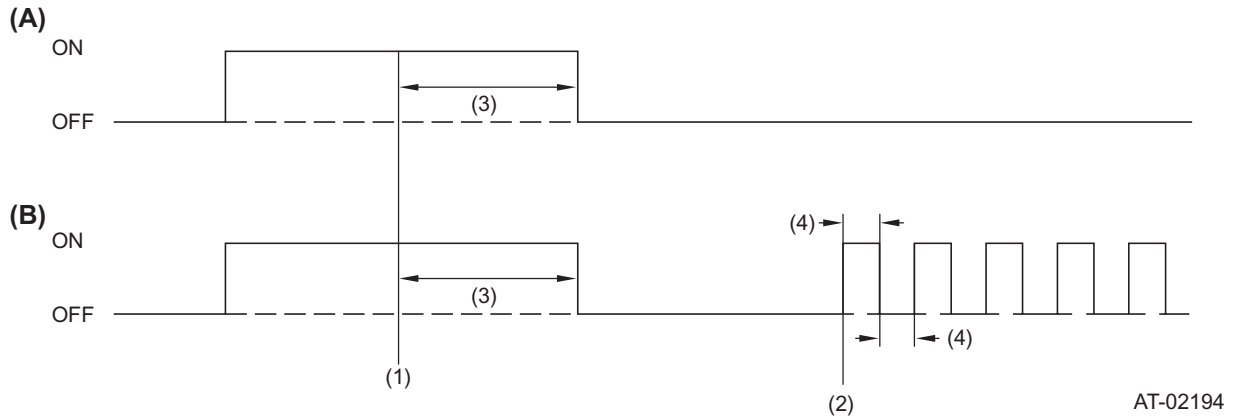

- (A) When normal
- (B) Abnormal

- (1) Engine cranking
- (2) Abnormality detected
- (3) 2 seconds
- (4) 0.25 seconds

AT-02194

18.Fail-safe Function

- Front and rear vehicle speed sensors, rear wheel speed sensor abnormal

If a fault is detected in either or both of the front vehicle speed sensor and rear vehicle speed sensor, the vehicle speed information received from the ABS unit via CAN communication is substituted for control. This enables normal quality shifting.

- Inhibitor switch abnormal

If an input of other than the specified pattern is entered to the TCM, the select position indicator lights in the combination meter are turned off, the starter is disabled, the reverse light is disabled, the transmission is fixed in D range, and manual mode is inhibited.

- PN signal abnormal

The output is turned OFF (starter inhibited) if an abnormality is detected in the PN signal output. However, if the ECM is receiving range signals through the backup of CAN communication, the starter can be used in P and N ranges.

- AT interlock decision

If an AT interlock decision is made, the vehicle's minimum mobility is maintained by fixing the transmission in 2nd, 4th or 5th speeds in accordance with the engaging pattern detected by the hydraulic switch. Relation between the hydraulic switch detection pattern and fixed gear speeds are as shown in the following table.

- Engine braking in 1st abnormal decision

If 1st engine braking abnormal decision is made, the low coast brake solenoid is deactivated to cancel the engine braking effect.

- Line pressure solenoid abnormal

The solenoid is deactivated and the line pressure set at maximum, 5th speed is inhibited. Except for this, the system is controlled normally.

- Lockup solenoid abnormal

The solenoid is deactivated and lockup is inhibited.

- Low coast brake solenoid abnormal

If the solenoid is failed and stuck in its ON state (electrically or mechanically) the transmission is fixed in 2nd speed, and when the solenoid is failed and stuck in its OFF state (electrically or mechanically) the solenoid is constantly turned OFF. (Engine braking is made not available in 1st and 2nd speeds.)

- Input clutch solenoid abnormal

If the solenoid is failed and stuck in its ON or OFF state (electrically or mechanically) the transmission is fixed in 4th speed to maintain mobility.

- Direct clutch solenoid abnormal

If the solenoid is failed and stuck in its ON or OFF state (electrically or mechanically) the transmission is fixed in 4th speed to maintain mobility.

- Front brake solenoid abnormal

If the solenoid is failed and stuck in its ON state (electrically or mechanically) the transmission is fixed in 5th speed, and when the solenoid is failed and stuck in its OFF state (electrically or mechanically) the transmission is fixed in 4th speed to maintain mobility.

- High and low reverse clutch solenoid abnormal

If the solenoid is failed and stuck in its ON or OFF state (electrically or mechanically) the transmission is fixed in 4th speed to maintain mobility.

FAIL-SAFE FUNCTION

AUTOMATIC TRANSMISSION

- Transfer clutch solenoid abnormal

If the solenoid is failed and stuck in its ON or OFF state, the transfer solenoid output is constantly turned OFF.

- Turbine sensor 1, 2 abnormal

Shifting control is performed without using turbine sensor values to maintain minimum mobility. 5th speed and manual mode are inhibited.

- TCM data communication abnormal

If communication with the memory box on the control valves fails, backup values stored in the TCM are used for controlling the solenoids.

- CAN communication abnormal

If an abnormality occurs in CAN communication, data received via CAN communication are fixed to preset values to perform shift control and maintain minimum mobility. Lockup and manual mode are inhibited.

Gear position	Oil pressure switch output					Fail safe	Clutch pressure output pattern in failsafe mode							
	Input clutch switch	High& low reverse clutch switch	Direct clutch switch	Front brake switch	Low coast brake switch		Input clutch solenoid	High & low reverse clutch solenoid	Direct clutch solenoid	Front brake solenoid	Low coast brake solenoid	Lockup solenoid	Transfer solenoid	
Interlock engaging pattern	1	x	○	—	○	○	Fixed in 4th	ON	ON	ON	OFF	OFF	OFF	ON
		—	○	x	—	○	Fixed in 4th	ON	ON	ON	OFF	OFF	OFF	ON
	2	—	x	○	—	○	Fixed in 4th	ON	ON	ON	OFF	OFF	OFF	ON
		x	—	○	○	—	Fixed in 4th	ON	ON	ON	OFF	OFF	OFF	ON
	3	—	○	○	—	x	Fixed in 2nd	OFF	OFF	ON	OFF	OFF	OFF	ON
		x	—	○	○	—	Fixed in 4th	ON	ON	ON	OFF	OFF	OFF	ON
	4	—	○	○	—	x	Fixed in 2nd	OFF	OFF	ON	OFF	OFF	OFF	ON
		○	—	○	x	—	Fixed in 5th	ON	ON	OFF	ON	OFF	OFF	ON
	5	○	○	—	○	x	Fixed in 2nd	OFF	OFF	ON	OFF	OFF	OFF	ON
		○	—	x	○	—	Fixed in 4th	ON	ON	ON	OFF	OFF	OFF	ON

x : Abnormal

○ : Normal

AT-02300

TRANSMISSION MOUNTING

AUTOMATIC TRANSMISSION

19. Transmission Mounting

A: GENERAL

The transmission mounting consists of a pitching stopper, cushion rubber, and a cross member.

In addition to support the transmission, these components absorb noise and vibration caused by the transmission.

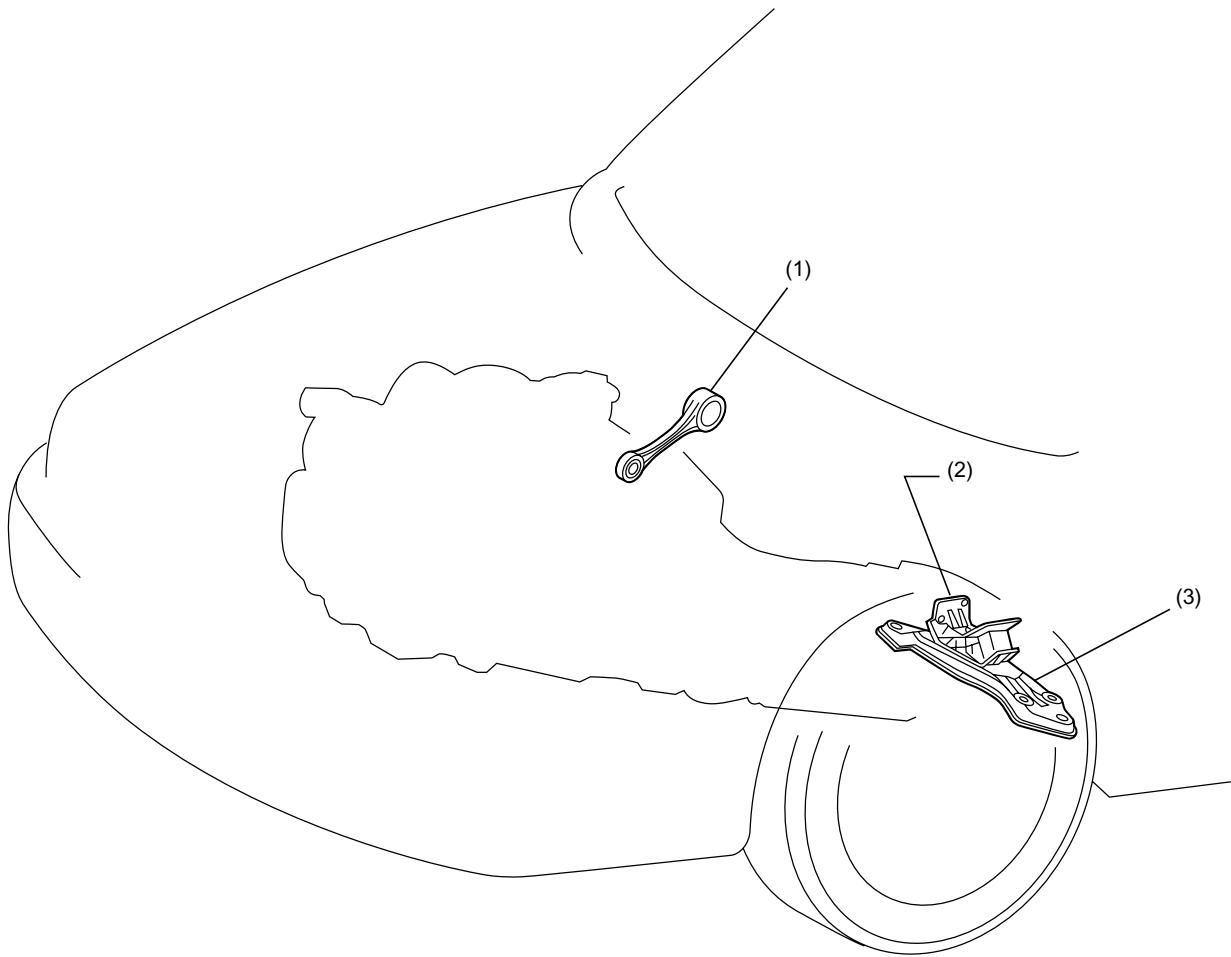

AT-00438

- (1) Pitching stopper
- (2) Cushion rubber
- (3) Cross member