

INTAKE (INDUCTION)

General Description

INTAKE (INDUCTION)

1. General Description

A: COMPONENT

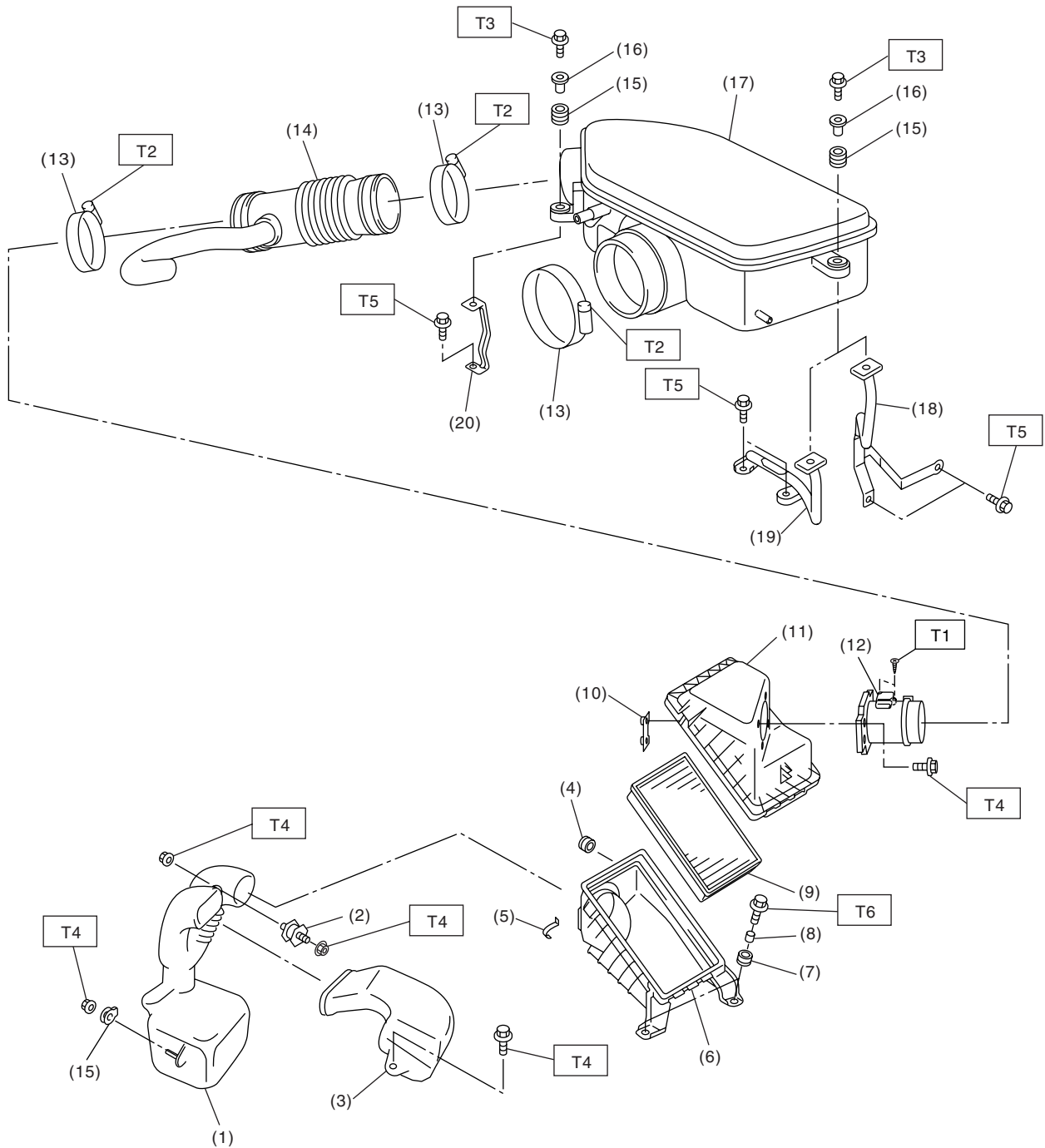

IN-02168

General Description

INTAKE (INDUCTION)

(1) Resonator chamber	(11) Air cleaner upper cover	(20) Stay RH
(2) Cushion	(12) Mass air flow and intake air temperature sensor	
(3) Air intake duct	(13) Clamp	
(4) Cushion	(14) Intake duct	
(5) Clip	(15) Cushion	
(6) Air cleaner lower case	(16) Spacer	
(7) Cushion	(17) Air intake chamber	
(8) Spacer	(18) Stay LH (MT model)	
(9) Air cleaner element	(19) Stay LH (AT model)	
(10) Guide		

Tightening torque: N·m (kgf·m, ft·lb)

T1: 1.0 (0.1, 0.7)

T2: 3.0 (0.3, 2.1)

T3: 6.5 (0.66, 4.8)

T4: 7.5 (0.76, 5.5)

T5: 16 (1.6, 11.6)

T6: 33 (3.4, 24.6)

B: CAUTION

- Wear work clothing, including a cap, protective goggles, and protective shoes during operation.
- Remove contamination including dirt and corrosion before removal, installation or disassembly.
- Keep the disassembled parts in order and protect them from dust and dirt.
- Before removal, installation or disassembly, be sure to clarify the failure. Avoid unnecessary removal, installation, disassembly, and replacement.
- Be careful not to burn yourself, because each part on the vehicle is hot after running.
- Be sure to tighten fasteners including bolts and nuts to the specified torque.
- Place shop jacks or rigid racks at the specified points.
- Before disconnecting electrical connectors of sensor or units, be sure to disconnect the ground cable from battery.

Air Cleaner Element

INTAKE (INDUCTION)

2. Air Cleaner Element

A: REMOVAL

1) Remove the clip (B) above air cleaner case.

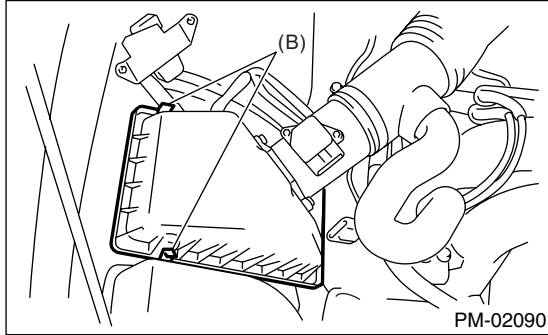

2) Remove the air cleaner element.

B: INSTALLATION

Install in the reverse order of removal.

NOTE:

Fasten it with a clip after inserting the lower tab of case.

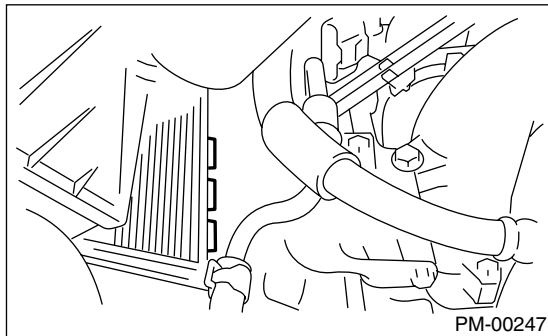

C: INSPECTION

Replace it if excessively damaged or dirty.

3. Air Cleaner Case

A: REMOVAL

- 1) Disconnect the ground cable from battery.
- 2) Loosen the clamp (A) which connects the air cleaner case and intake duct.
- 3) Remove the clips (B) of air cleaner case.
- 4) Disconnect the connector (C) of mass air flow and intake air temperature sensor.

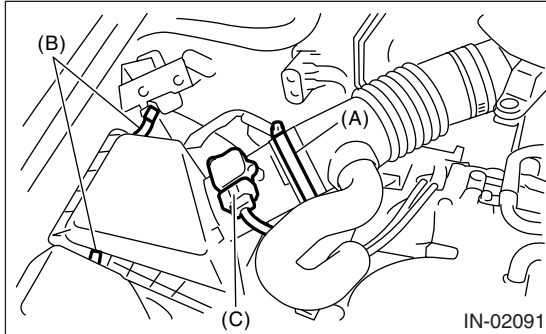

- 5) Remove the intake duct and upper cover from air cleaner case.
- 6) Remove the air cleaner element.
- 7) Remove the bolts which install the air cleaner case to body.

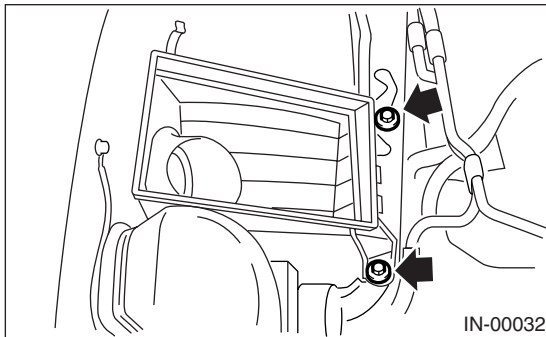

- 8) Remove the air cleaner case.

B: INSTALLATION

Install in the reverse order of removal.

Tightening torque:

33 N·m (3.4 kgf·m, 24.6 ft·lb)

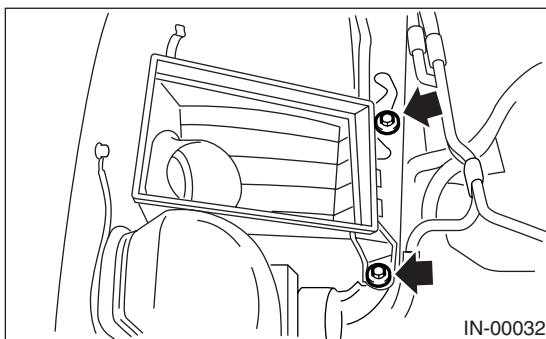

C: INSPECTION

Inspect for cracks and loose connections.

4. Air Intake Chamber

A: REMOVAL

- 1) Loosen the clamp (A) which connects the air intake chamber and throttle body.
- 2) Loosen the clamp (B) which connects the air intake chamber and intake duct.
- 3) Remove the bolts (C) which connects the air intake chamber to the stay.
- 4) Disconnect the connector (D).

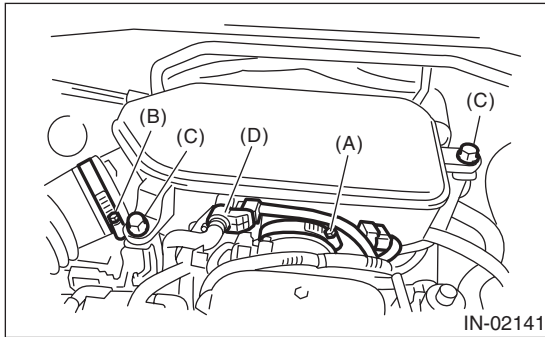

- 5) Disconnect the two blow-by hoses, and then remove the air intake chamber.

B: INSTALLATION

Install in the reverse order of removal.

Tightening torque:

Clamp (A), (B)

3 N·m (0.3 kgf-m, 2.1 ft-lb)

Bolt (C)

6.5 N·m (0.66 kgf-m, 4.8 ft-lb)

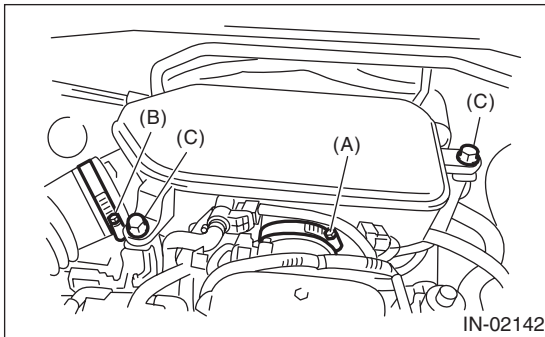

C: INSPECTION

- 1) Inspect for cracks and loose connections.
- 2) Inspect that no foreign objects are mixed in air intake chamber.

5. Air Intake Duct

A: REMOVAL

- 1) Remove the bolts which install the air intake duct on the front side of body.
- 2) Remove the air intake duct.

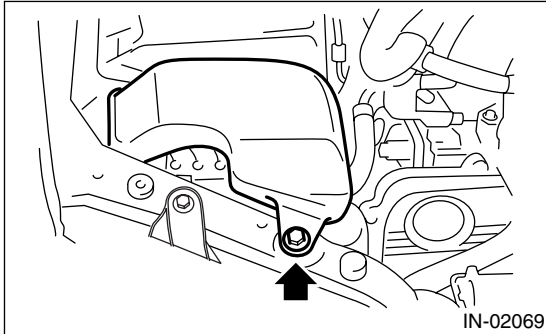

B: INSTALLATION

Install in the reverse order of removal.

Tightening torque:

7.5 N·m (0.76 kgf-m, 5.5 ft-lb)

C: INSPECTION

- 1) Inspect for cracks and loose connections.
- 2) Inspect that no foreign objects are mixed in the air intake duct.

6. Resonator Chamber

A: REMOVAL

- 1) Set the vehicle on a lift.
- 2) Remove the air intake duct.
- 3) Remove the air cleaner lower case. <Ref. to IN(H4SO)-5, REMOVAL, Air Cleaner Case.>
- 4) Remove the resonator chamber mounting nut on the right side of engine compartment.

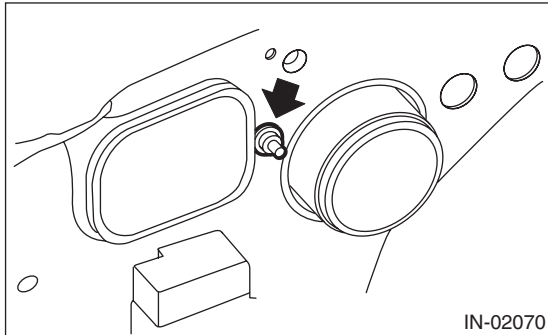

- 5) Lift-up the vehicle, and then remove the front wheel RH.
- 6) Remove the front mud guard RH.
- 7) Remove the resonator chamber from inside front fender.

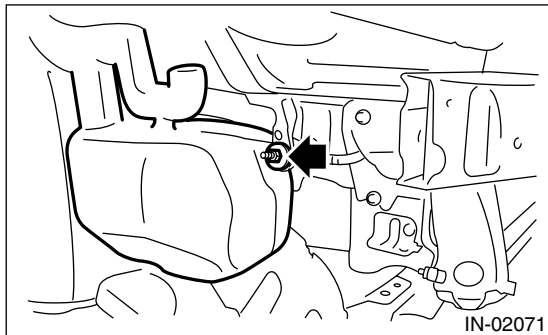

B: INSTALLATION

Install in the reverse order of removal.

Tightening torque:

7.5 N·m (0.76 kgf-m, 5.5 ft-lb)

C: INSPECTION

- 1) Inspect for cracks and loose connections.
- 2) Inspect that no foreign objects are mixed in resonator chamber.