

COOLING

General Description

COOLING

1. General Description

A: SPECIFICATION

Cooling system		Electric fan + Forced engine coolant circulation system	
Total engine coolant capacity		\varnothing (US qt, Imp qt) AT model: Approx. 6.9 (7.3, 6.1) MT model: Approx. 7.0 (7.4, 6.2)	
Water pump	Type	Centrifugal impeller type	
	Discharge performance I	Discharge	20 \varnothing (5.3 US gal, 4.4 Imp gal)/min.
		Pump speed — Discharge pressure	760 rpm — 2.9 kPa (0.3 mAq)
		Engine coolant temperature	80°C (176°F)
	Discharge performance II	Discharge	100 \varnothing (26.4 US gal, 22.0 Imp gal)/min.
		Pump speed — Discharge pressure	3,000 rpm — 49.0 kPa (5.0 mAq)
		Engine coolant temperature	80°C (176°F)
	Discharge performance III	Discharge	200 \varnothing (52.8 US gal, 44.0 Imp gal)/min.
		Pump speed — Discharge pressure	6,000 rpm — 225.4 kPa (23.0 mAq)
		Engine coolant temperature	80°C (176°F)
Impeller diameter	76 mm (2.99 in)		
Number of impeller vanes	8		
Pump pulley diameter	60 mm (2.36 in)		
Clearance between impeller and case	Standard	0.5 — 1.5 mm (0.020 — 0.060 in)	
Thermostat	Type	Wax pellet type	
	Starts to open	80 — 84°C (176 — 183°F)	
	Fully opened	95°C (203°F)	
	Valve lift	9.0 mm (0.354 in) or more	
	Valve bore	35 mm (1.38 in)	
Radiator fan	Motor	Main fan	120 W
		Sub fan	120 W
Fan diameter × Blade		320 mm (12.60 in) × 5 (main fan) 320 mm (12.60 in) × 7 (sub fan)	
Radiator	Type	Down flow	
	Core dimensions	Width × Height × Thickness	691.5 × 340 × 16 mm (27.22 × 13.39 × 0.63 in)
	Pressure range in which cap valve is open		Above: 108±15 kPa (1.1±0.15 kgf/cm ² , 16±2 psi) Below: -1.0 to -4.9 kPa (-0.01 to -0.05 kgf/cm ² , -0.1 to -0.7 psi)
	Fins		Corrugated fin type
Reservoir tank	Capacity	0.5 \varnothing (0.5 US qt, 0.4 Imp qt)	

B: COMPONENT

1. WATER PUMP

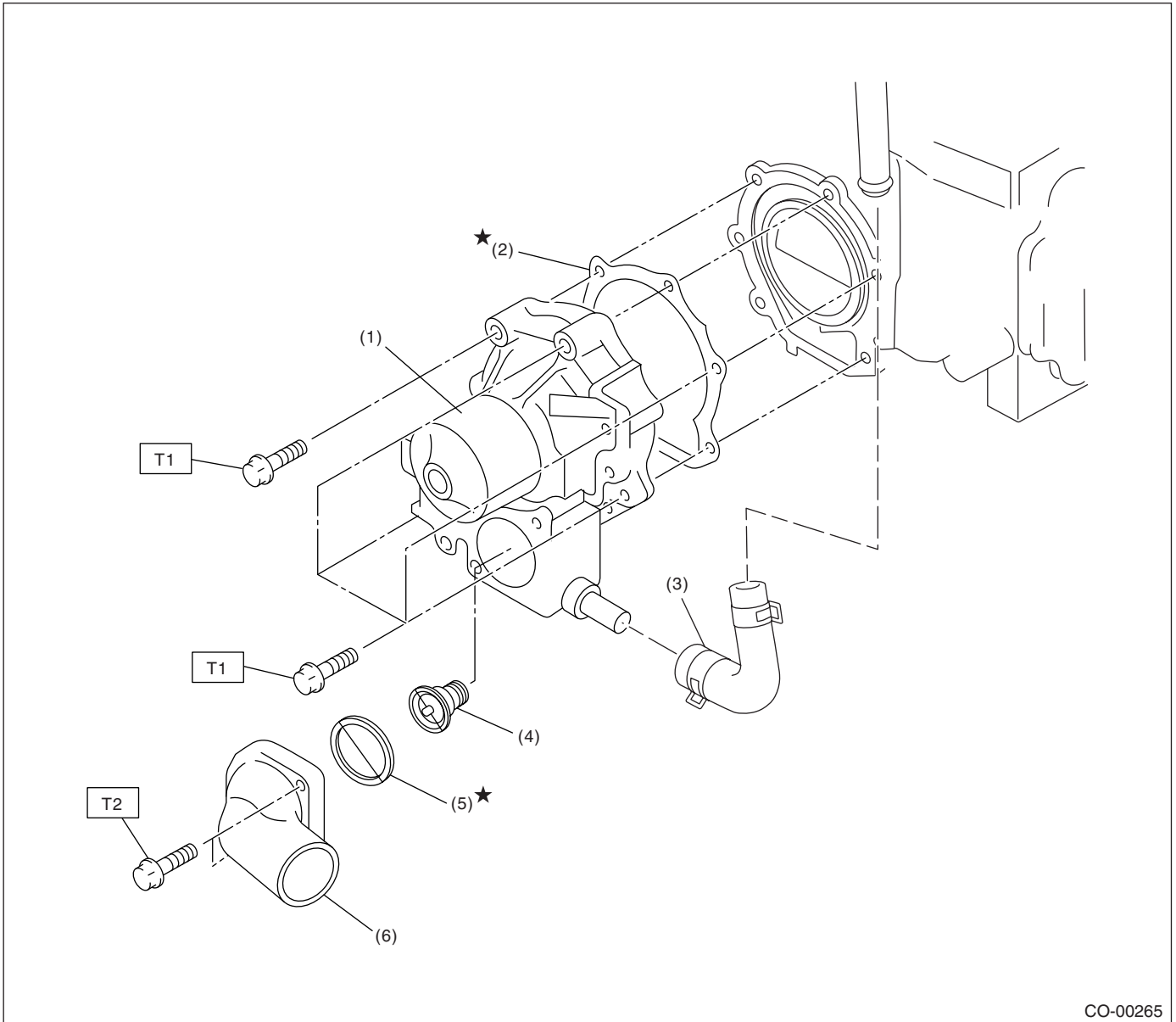

CO-00265

- | | |
|-------------------------|----------------------|
| (1) Water pump ASSY | (5) Gasket |
| (2) Gasket | (6) Thermostat cover |
| (3) Heater by-pass hose | |
| (4) Thermostat | |

Tightening torque: N·m (kgf·m, ft·lb)

**T1: First 12 (1.2, 8.7)
Second 12 (1.2, 8.7)**

T2: 12 (1.2, 8.7)

General Description

COOLING

2. RADIATOR AND RADIATOR FAN

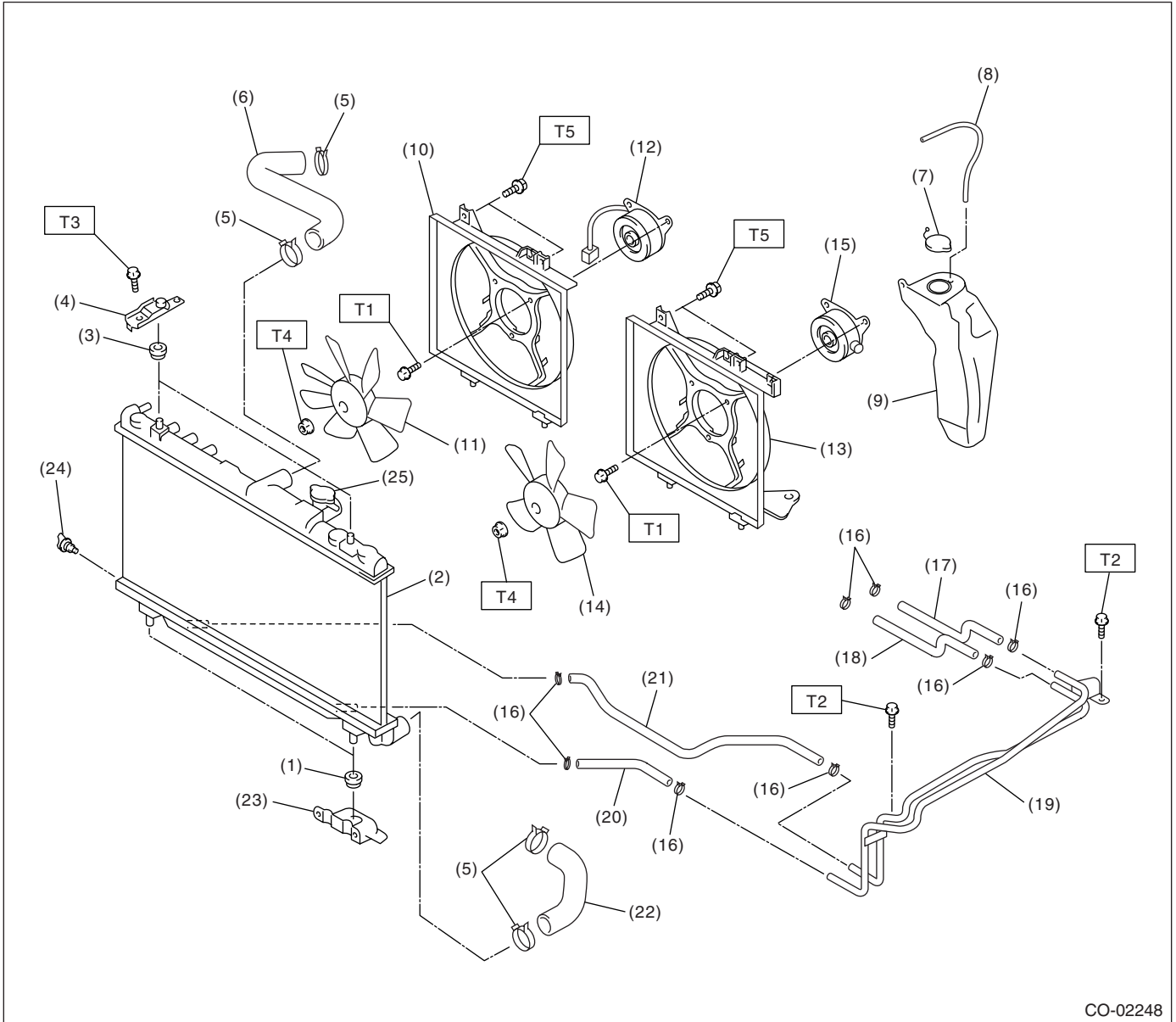

CO-02248

- | | | |
|---------------------------------------|-----------------------------------|-----------------------------|
| (1) Radiator lower cushion | (12) Radiator sub fan motor | (23) Radiator lower bracket |
| (2) Radiator | (13) Radiator main fan shroud | (24) Radiator drain plug |
| (3) Radiator upper cushion | (14) Radiator main fan | (25) Radiator cap |
| (4) Radiator upper bracket | (15) Radiator main fan motor | |
| (5) Clamp | (16) ATF hose clamp (AT model) | |
| (6) Radiator inlet hose | (17) ATF inlet hose A (AT model) | |
| (7) Engine coolant reservoir tank cap | (18) ATF outlet hose A (AT model) | |
| (8) Overflow hose | (19) ATF pipe (AT model) | |
| (9) Engine coolant reservoir tank | (20) ATF inlet hose B (AT model) | |
| (10) Radiator sub fan shroud | (21) ATF outlet hose B (AT model) | |
| (11) Radiator sub fan | (22) Radiator outlet hose | |

Tightening torque: N·m (kgf-m, ft-lb)

T1: 4.4 (0.45, 3.3)

T2: 12 (1.2, 8.7)

T3: 18 (1.8, 13.0)

T4: 3.4 (0.35, 2.5)

T5: 4.9 (0.50, 3.6)

C: CAUTION

- Wear work clothing, including a cap, protective goggles, and protective shoes during operation.
- Remove contamination including dirt and corrosion before removal, installation or disassembly.
- Keep the disassembled parts in order and protect them from dust and dirt.
- Before removal, installation or disassembly, be sure to clarify the failure. Avoid unnecessary removal, installation, disassembly and replacement.
- Be careful not to burn your hands, because each part in the vehicle is hot after running.
- Be sure to tighten fasteners including bolts and nuts to the specified torque.
- Place shop jacks or rigid racks at the specified points.
- Before disconnecting electrical connectors of sensors or units, be sure to disconnect the ground cable from battery.

D: PREPARATION TOOL

1. SPECIAL TOOL

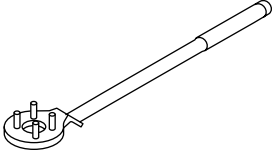
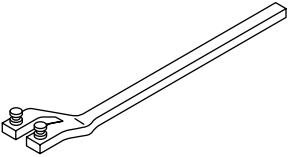
ILLUSTRATION	TOOL NUMBER	DESCRIPTION	REMARKS
 <p style="text-align: center;">ST-499977100</p>	499977100	CRANK PULLEY WRENCH	Used for stopping rotation of crank pulley when loosening and tightening crankshaft pulley bolt.
 <p style="text-align: center;">ST18231AA010</p>	18231AA010	CAM SPROCKET WRENCH	<ul style="list-style-type: none"> • Used for removing and installing cam sprocket. • Also the CAM SPROCKET WRENCH (499207100) can be used.

Radiator Main Fan System

COOLING

2. Radiator Main Fan System

A: WIRING DIAGRAM

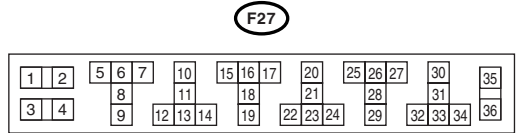
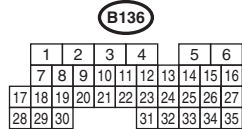
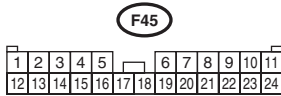
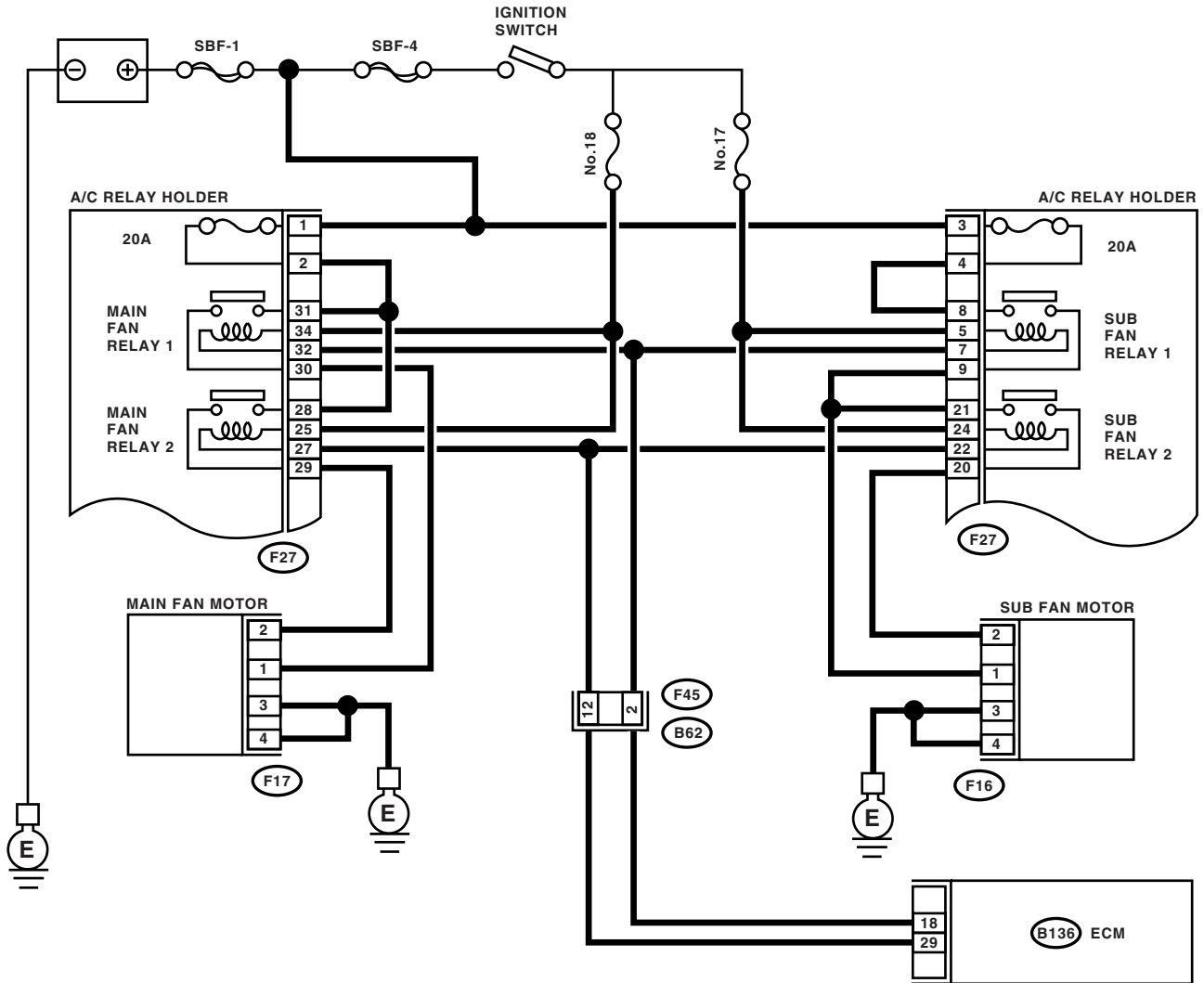

RELAY HOLDER (BLACK)

CO-02237

B: INSPECTION

DETECTING CONDITION:

- Engine coolant temperature is above 96°C (205°F).
- A/C compressor is rotated.
- Vehicle speed is below 19 km/h (12 MPH).

TROUBLE SYMPTOM:

- Radiator main fan does not rotate under the above conditions.
- Radiator main fan does not rotate at high speed when the following conditions are both met:
 - (1) Engine coolant temperature is above 90°C (194°F).
 - (2) A/C is ON.

Step	Check	Yes	No
1 CHECK OPERATION OF RADIATOR. 1) Run the engine at idle. (Vehicle stationary) 2) Turn the A/C switch to OFF. 3) Warm the engine coolant temperature over 96°C (205°F).	Does the main radiator fan rotate?	Go to step 2.	Go to step 3.
2 CHECK OPERATION OF RADIATOR. Turn the A/C switch to ON at condition of step 1.	Does the main radiator fan rotate faster when A/C compressor is operated?	Radiator main fan system is okay.	Go to step 17.
3 CHECK POWER SUPPLY TO MAIN FAN MOTOR. CAUTION: Be careful not to overheat the engine during repair. 1) Turn the ignition switch to OFF. 2) Disconnect the connector from main fan motor. 3) Start the engine, and warm it up until engine coolant temperature increases over 96°C (205°F). 4) Stop the engine and turn ignition switch to ON. 5) Measure the voltage between main fan motor connector and chassis ground. Connector & terminal (F17) No. 1 (+) — Chassis ground (-):	Is the voltage more than 10 V?	Go to step 4.	Go to step 7.
4 CHECK GROUND CIRCUIT OF MAIN FAN MOTOR. 1) Turn the ignition switch to OFF. 2) Measure the resistance between main fan motor connector and chassis ground. Connector & terminal (F17) No. 3 — Chassis ground: (F17) No. 4 — Chassis ground:	Is the resistance less than 5 Ω?	Go to step 5.	Repair the open circuit in harness between main fan motor connector and chassis ground.
5 CHECK POOR CONTACT. Check poor contact in main fan motor connector.	Is there poor contact in main fan motor connector?	Repair the poor contact in main fan motor connector.	Go to step 6.
6 CHECK MAIN FAN MOTOR. Connect the battery positive (+) terminal to terminal No. 1, and ground (-) terminal to terminal No. 3 or No. 4 of main fan motor connector.	Does the main fan rotate?	Repair the poor contact in main fan motor connector.	Replace the main fan motor with a new one.

Radiator Main Fan System

COOLING

Step	Check	Yes	No
7 CHECK POWER SUPPLY TO MAIN FAN RELAY1. 1) Turn the ignition switch to OFF. 2) Remove the main fan relay1 from A/C relay holder. 3) Measure the voltage between main fan relay1 terminal and chassis ground. Connector & terminal (F27) No. 31 (+) — Chassis ground (-):	Is the voltage more than 10 V?	Go to step 8.	Go to step 9.
8 CHECK POWER SUPPLY TO MAIN FAN RELAY1. 1) Turn the ignition switch to ON. 2) Measure the voltage between main fan relay1 terminal and chassis ground. Connector & terminal (F27) No. 34 (+) — Chassis ground (-):	Is the voltage more than 10 V?	Go to step 12.	Go to step 11.
9 CHECK 20 A FUSE. 1) Remove the 20 A fuse from A/C relay holder. 2) Check the condition of fuse.	Is the fuse blown out?	Replace the fuse.	Go to step 10.
10 CHECK POWER SUPPLY TO A/C RELAY HOLDER 20 A FUSE TERMINAL. Measure the voltage of harness between A/C relay holder 20 A fuse terminal and chassis ground. Connector & terminal (F27) No. 1 (+) — Chassis ground (-):	Is the voltage more than 10 V?	Repair the open circuit in harness between 20 A fuse and main fan relay terminal.	Repair the open circuit in harness between main fuse box connector and 20 A fuse terminal.
11 CHECK FUSE. 1) Turn the ignition switch to OFF. 2) Remove the fuse No. 18 from joint box. 3) Check the condition of fuse.	Is the fuse blown out?	Replace the fuse.	Repair the open circuit in harness between main fan relay and ignition switch.
12 CHECK MAIN FAN RELAY. 1) Turn the ignition switch to OFF. 2) Remove the main fan relay1. 3) Measure the resistance of main fan relay1. Terminals No. 30 — No. 31:	Is the resistance more than 1 M Ω ?	Go to step 13.	Replace the main fan relay.
13 CHECK MAIN FAN RELAY. 1) Connect the battery to terminals No. 34 and No. 32 of main fan relay1. 2) Measure the resistance of main fan relay1. Terminals No. 30 — No. 31:	Is the resistance less than 1 Ω ?	Go to step 14.	Replace the main fan relay.
14 CHECK HARNESS BETWEEN MAIN FAN RELAY TERMINAL AND MAIN FAN MOTOR CONNECTOR. Measure the resistance of harness between main fan motor connector and main fan relay terminal. Connector & terminal (F17) No. 1 — (F27) No. 30:	Is the resistance less than 1 Ω ?	Go to step 15.	Repair the open circuit in harness between main fan motor connector and main fan relay terminal.

Radiator Main Fan System

COOLING

Step	Check	Yes	No
15 CHECK HARNESS BETWEEN MAIN FAN RELAY AND ECM. 1) Turn the ignition switch to OFF. 2) Disconnect the connector from ECM. 3) Measure the resistance of harness between main fan relay connector and ECM connector. <i>Connector & terminal</i> <i>(F27) No. 32 — (B136) No. 18:</i>	Is the resistance less than 1 Ω ?	Go to step 16.	Repair the open circuit in harness between main fan relay and ECM.
16 CHECK POOR CONTACT. Check poor contact in connector between main fan and ECM.	Is there poor contact in connector between main fan motor and ECM?	Repair the poor contact connector.	Record the DTC. Repair the trouble cause. <Ref. to EN(H4SO)(diag)-35, Read Diagnostic Trouble Code (DTC).>
17 CHECK POWER SUPPLY TO MAIN FAN MOTOR. CAUTION: Be careful not to overheat the engine during repair. 1) Turn the ignition switch to OFF. 2) Disconnect the connector from main fan motor. 3) Start the engine, and warm it up until engine coolant temperature increases over 96°C (205°F). 4) Turn the A/C switch ON. 5) Measure the voltage while A/C compressor is rotating. 6) Measure the voltage between main fan motor connector and chassis ground. <i>Connector & terminal</i> <i>(F17) No. 2 (+) — Chassis ground (-):</i>	Is the voltage more than 10 V?	Go to step 18.	Go to step 20.
18 CHECK POOR CONTACT. Check poor contact in main fan motor connector.	Is there poor contact in main fan motor connector?	Repair the poor contact in main fan motor connector.	Go to step 19.
19 CHECK MAIN FAN MOTOR. Connect the battery positive (+) terminal to terminal No. 2, and ground (-) terminal to terminal No. 3 or No. 4 of main fan motor connector.	Does the main fan rotate?	Repair the poor contact in main fan motor connector.	Replace the main fan motor with a new one.
20 CHECK POWER SUPPLY TO MAIN FAN RELAY2. 1) Turn the ignition switch to OFF. 2) Remove the main fan relay2 from A/C relay holder. 3) Measure the voltage between main fan relay2 terminal and chassis ground. <i>Connector & terminal</i> <i>(F27) No. 28 (+) — Chassis ground (-):</i>	Is the voltage more than 10 V?	Go to step 21.	Go to step 22.
21 CHECK POWER SUPPLY TO MAIN FAN RELAY2. 1) Turn the ignition switch to ON. 2) Measure the voltage between main fan relay2 terminal and chassis ground. <i>Connector & terminal</i> <i>(F27) No. 25 (+) — Chassis ground (-):</i>	Is the voltage more than 10 V?	Go to step 25.	Go to step 24.

Radiator Main Fan System

COOLING

Step	Check	Yes	No
22 CHECK 20 A FUSE. 1) Remove the 20 A fuse from A/C relay holder. 2) Check the condition of fuse.	Is the fuse blown out?	Replace the fuse.	Go to step 23 .
23 CHECK POWER SUPPLY TO A/C RELAY HOLDER 20 A FUSE TERMINAL. Measure the voltage of harness between A/C relay holder 20 A fuse terminal and chassis ground. Connector & terminal (F27) No. 1 (+) — Chassis ground (-):	Is the voltage more than 10 V?	Repair the open circuit in harness between 20 A fuse and main fan relay terminal.	Repair the open circuit in harness between main fan box connector and 20 A fuse terminal.
24 CHECK FUSE. 1) Turn the ignition switch to OFF. 2) Remove the fuse No. 18 from joint box. 3) Check the condition of fuse.	Is the fuse blown out?	Replace the fuse.	Repair the open circuit in harness between main fan relay and ignition switch.
25 CHECK MAIN FAN RELAY. 1) Turn the ignition switch to OFF. 2) Remove the main fan relay. 3) Measure the resistance of main fan relay. Terminals No. 28 — No. 29:	Is the resistance more than 1 M Ω ?	Go to step 26 .	Replace the main fan relay.
26 CHECK MAIN FAN RELAY. 1) Connect the battery to terminals No. 25 and No. 27 of main fan relay. 2) Measure the resistance of main fan relay. Terminals No. 28 — No. 29:	Is the resistance less than 1 Ω ?	Go to step 27 .	Replace the main fan relay.
27 CHECK HARNESS BETWEEN MAIN FAN RELAY TERMINAL AND MAIN FAN MOTOR CONNECTOR. Measure the resistance of harness between main fan motor connector and main fan relay terminal. Connector & terminal (F17) No. 2 — (F27) No. 29:	Is the resistance less than 1 Ω ?	Go to step 28 .	Repair the open circuit in harness between main fan motor connector and main fan relay terminal.
28 CHECK HARNESS BETWEEN MAIN FAN RELAY AND ECM. 1) Turn the ignition switch to OFF. 2) Disconnect the connector from ECM. 3) Measure the resistance of harness between main fan relay connector and ECM connector. Connector & terminal (F27) No. 27 — (B136) No. 29:	Is the resistance less than 1 Ω ?	Go to step 29 .	Repair the open circuit in harness between main fan relay and ECM.
29 CHECK POOR CONTACT. Check poor contact in connector between main fan and ECM.	Is there poor contact in connector between main fan motor and ECM?	Repair the poor contact connector.	Record the DTC. Repair the trouble cause. <Ref. to EN(H4SO)(diag)-35, Read Diagnostic Trouble Code (DTC).>

3. Radiator Sub Fan System

A: WIRING DIAGRAM

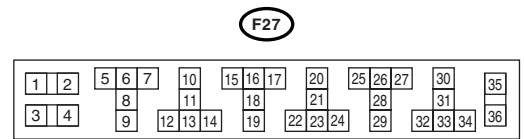
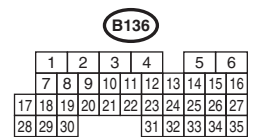
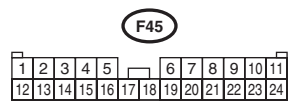
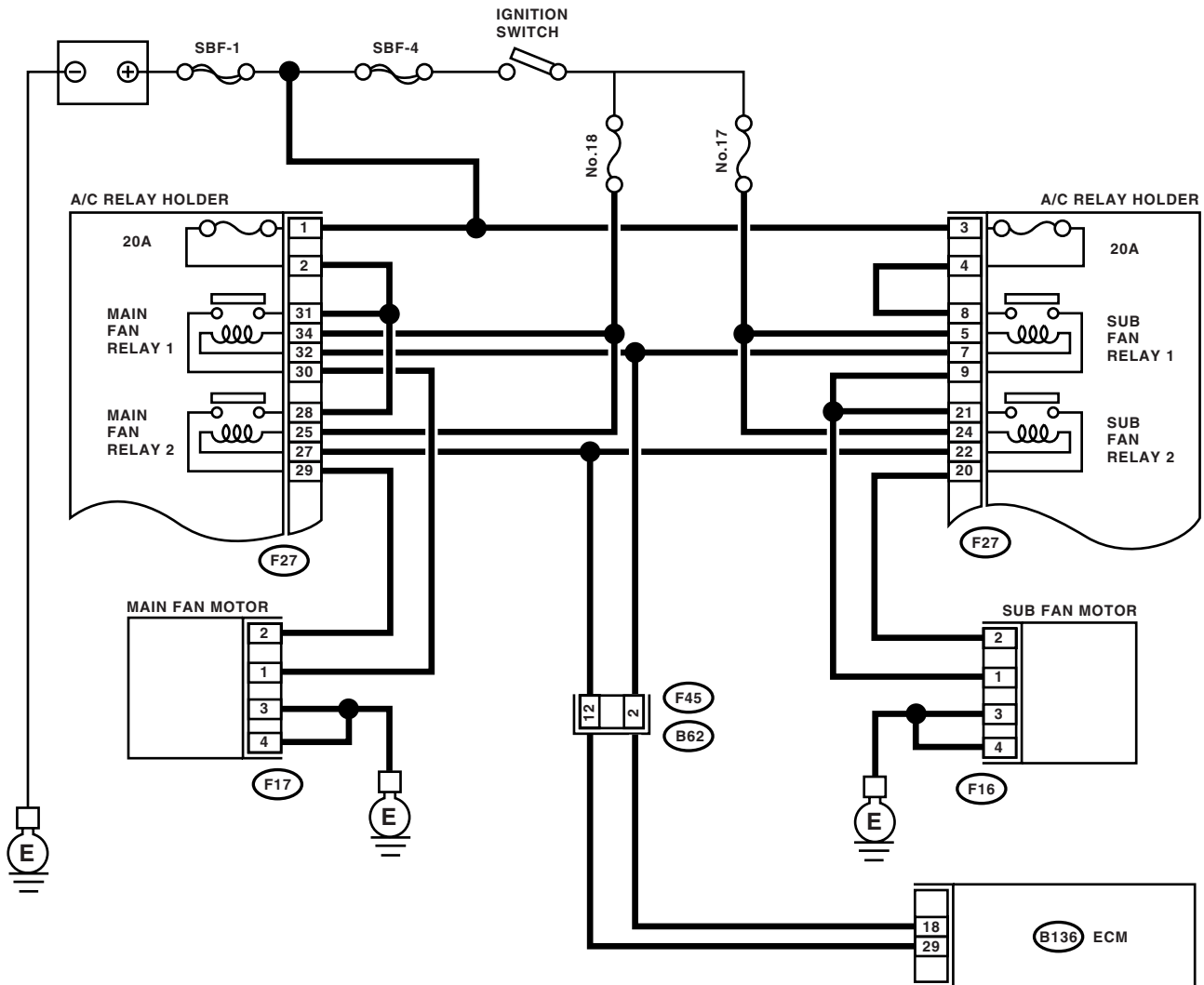

RELAY HOLDER (BLACK)

Radiator Sub Fan System

COOLING

B: INSPECTION

DETECTING CONDITION:

- Engine coolant temperature is above 96°C (205°F).
- A/C compressor is rotated.
- Vehicle speed is below 19 km/h (12 MPH).

TROUBLE SYMPTOM:

- Radiator sub fan does not rotate under the above conditions.
- Radiator sub fan does not rotate at high speed when the following conditions are both met:
 - (1) Engine coolant temperature is above 90°C (194°F).
 - (2) A/C is ON.

	Step	Check	Yes	No
1	CHECK OPERATION OF RADIATOR. 1) Run the engine at idle. (Vehicle stationary) 2) Turn the A/C switch to OFF. 3) Warm the engine coolant temperature over 96°C (205°F).	Does the radiator sub fan rotate?	Go to step 2.	Go to step 3.
2	CHECK OPERATION OF RADIATOR. Turn the A/C switch to ON at condition of step 1.	Does the radiator sub fan rotate faster when A/C compressor is operated?	Radiator sub fan system is okay.	Go to step 17.
3	CHECK POWER SUPPLY TO SUB FAN MOTOR. CAUTION: Be careful not to overheat the engine during repair. 1) Turn the ignition switch to OFF. 2) Disconnect the connector from sub fan motor. 3) Start the engine, and warm it up until engine coolant temperature increases over 96°C (205°F). 4) Stop the engine and turn ignition switch to ON. 5) Measure the voltage between sub fan motor connector and chassis ground. Connector & terminal (F16) No. 1 (+) — Chassis ground (-):	Is the voltage more than 10 V?	Go to step 4.	Go to step 7.
4	CHECK GROUND CIRCUIT OF SUB FAN MOTOR. 1) Turn the ignition switch to OFF. 2) Measure the resistance between sub fan motor connector and chassis ground. Connector & terminal (F16) No. 3 — Chassis ground: (F16) No. 4 — Chassis ground:	Is the resistance less than 5 Ω?	Go to step 5.	Repair the open circuit in harness between sub fan motor connector and chassis ground.
5	CHECK POOR CONTACT. Check poor contact in sub fan motor connector.	Is there poor contact in sub fan motor connector?	Repair the poor contact in sub fan motor connector.	Go to step 6.
6	CHECK SUB FAN MOTOR. Connect the battery positive (+) terminal to terminal No. 1, and ground (-) terminal to terminal No. 3 or No. 4 of sub fan motor connector.	Does the sub fan rotate?	Repair the poor contact in sub fan motor connector.	Replace the sub fan motor with a new one.

Radiator Sub Fan System

COOLING

Step	Check	Yes	No
7 CHECK POWER SUPPLY TO SUB FAN RELAY1. 1) Turn the ignition switch to OFF. 2) Remove the sub fan relay1 from A/C relay holder. 3) Measure the voltage between sub fan relay1 terminal and chassis ground. Connector & terminal (F27) No. 8 (+) — Chassis ground (-):	Is the voltage more than 10 V?	Go to step 8.	Go to step 9.
8 CHECK POWER SUPPLY TO SUB FAN RELAY1. 1) Turn the ignition switch to ON. 2) Measure the voltage between sub fan relay1 terminal and chassis ground. Connector & terminal (F27) No. 5 (+) — Chassis ground (-):	Is the voltage more than 10 V?	Go to step 12.	Go to step 11.
9 CHECK 20 A FUSE. 1) Remove the 20 A fuse from A/C relay holder. 2) Check the condition of fuse.	Is the fuse blown out?	Replace the fuse.	Go to step 10.
10 CHECK POWER SUPPLY TO A/C RELAY HOLDER 20 A FUSE TERMINAL. Measure the voltage of harness between A/C relay holder 20 A fuse terminal and chassis ground. Connector & terminal (F27) No. 3 (+) — Chassis ground (-):	Is the voltage more than 10 V?	Repair the open circuit in harness between 20 A fuse and sub fan relay terminal.	Repair the open circuit in harness between sub fuse box connector and 20 A fuse terminal.
11 CHECK FUSE. 1) Turn the ignition switch to OFF. 2) Remove the fuse No. 17 from joint box. 3) Check the condition of fuse.	Is the fuse blown out?	Replace the fuse.	Repair the open circuit in harness between sub fan relay and ignition switch.
12 CHECK SUB FAN RELAY. 1) Turn the ignition switch to OFF. 2) Remove the sub fan relay1. 3) Measure the resistance of sub fan relay1. Terminals No. 8 — No. 9:	Is the resistance more than 1 MΩ?	Go to step 13.	Replace the sub fan relay.
13 CHECK SUB FAN RELAY. 1) Connect the battery to terminals No. 5 and No. 7 of sub fan relay1. 2) Measure the resistance of sub fan relay. Terminals No. 8 — No. 9:	Is the resistance less than 1 Ω?	Go to step 14.	Replace the sub fan relay.
14 CHECK HARNESS BETWEEN SUB FAN RELAY TERMINAL AND SUB FAN MOTOR CONNECTOR. Measure the resistance of harness between sub fan motor connector and sub fan relay terminal. Connector & terminal (F16) No. 1 — (F27) No. 9:	Is the resistance less than 1 Ω?	Go to step 15.	Repair the open circuit in harness between sub fan motor connector and sub fan relay terminal.

Radiator Sub Fan System

COOLING

Step	Check	Yes	No
15 CHECK HARNESS BETWEEN SUB FAN RELAY AND ECM. 1) Turn the ignition switch to OFF. 2) Disconnect the connector from ECM. 3) Measure the resistance of harness between sub fan relay connector and ECM connector. <i>Connector & terminal</i> <i>(F27) No. 7 — (B136) No. 18:</i>	Is the resistance less than 1 Ω ?	Go to step 16.	Repair the open circuit in harness between sub fan relay and ECM.
16 CHECK POOR CONTACT. Check poor contact in connector between sub fan and ECM.	Is there poor contact in connector between sub fan motor and ECM?	Repair the poor contact connector.	Record the DTC. Repair the trouble cause. <Ref. to EN(H4SO)(diag)-35, Read Diagnostic Trouble Code (DTC).>
17 CHECK POWER SUPPLY TO SUB FAN MOTOR. CAUTION: Be careful not to overheat the engine during repair. 1) Turn the ignition switch to OFF. 2) Disconnect the connector from sub fan motor. 3) Start the engine, and warm it up until engine coolant temperature increases over 96°C (205°F). 4) Turn the A/C switch ON. 5) Measure the voltage while A/C compressor is rotating. 6) Measure the voltage between sub fan motor connector and chassis ground. <i>Connector & terminal</i> <i>(F16) No. 2 (+) — Chassis ground (-):</i>	Is the voltage more than 10 V?	Go to step 18.	Go to step 20.
18 CHECK POOR CONTACT. Check poor contact in sub fan motor connector.	Is there poor contact in sub fan motor connector?	Repair the poor contact in sub fan motor connector.	Go to step 19.
19 CHECK SUB FAN MOTOR. Connect the battery positive (+) terminal to terminal No. 2, and ground (-) terminal to terminal No. 3 or No. 4 of sub fan motor connector.	Does the sub fan rotate?	Repair the poor contact in sub fan motor connector.	Replace the sub fan motor with a new one.
20 CHECK POWER SUPPLY TO SUB FAN RELAY2. 1) Turn the ignition switch to OFF. 2) Remove the sub fan relay2 from A/C relay holder. 3) Measure the voltage between sub fan relay2 terminal and chassis ground. <i>Connector & terminal</i> <i>(F27) No. 21 (+) — Chassis ground (-):</i>	Is the voltage more than 10 V?	Go to step 21.	Go to step 22.
21 CHECK POWER SUPPLY TO SUB FAN RELAY2. 1) Turn the ignition switch to ON. 2) Measure the voltage between sub fan relay2 terminal and chassis ground. <i>Connector & terminal</i> <i>(F27) No. 24 (+) — Chassis ground (-):</i>	Is the voltage more than 10 V?	Go to step 25.	Go to step 24.

Radiator Sub Fan System

COOLING

Step	Check	Yes	No
22 CHECK 20 A FUSE. 1) Remove the 20 A fuse from A/C relay holder. 2) Check the condition of fuse.	Is the fuse blown out?	Replace the fuse.	Go to step 23 .
23 CHECK POWER SUPPLY TO A/C RELAY HOLDER 20 A FUSE TERMINAL. Measure the voltage of harness between A/C relay holder 20 A fuse terminal and chassis ground. <i>Connector & terminal</i> <i>(F27) No. 3 (+) — Chassis ground (-):</i>	Is the voltage more than 10 V?	Repair the open circuit in harness between 20 A fuse and sub fan relay terminal.	Repair the open circuit in harness between sub fuse box connector and 20 A fuse terminal.
24 CHECK FUSE. 1) Turn the ignition switch to OFF. 2) Remove the fuse No. 17 from joint box. 3) Check the condition of fuse.	Is the fuse blown out?	Replace the fuse.	Repair the open circuit in harness between sub fan relay and ignition switch.
25 CHECK SUB FAN RELAY. 1) Turn the ignition switch to OFF. 2) Remove the sub fan relay. 3) Measure the resistance of sub fan relay. <i>Terminals</i> <i>No. 20 — No. 21:</i>	Is the resistance more than 1 M Ω ?	Go to step 26 .	Replace the sub fan relay.
26 CHECK SUB FAN RELAY. 1) Connect the battery to terminals No. 22 and No. 24 of sub fan relay. 2) Measure the resistance of sub fan relay. <i>Terminals</i> <i>No. 20 — No. 21:</i>	Is the resistance less than 1 Ω ?	Go to step 27 .	Replace the sub fan relay.
27 CHECK HARNESS BETWEEN SUB FAN RELAY TERMINAL AND SUB FAN MOTOR CONNECTOR. Measure the resistance of harness between sub fan motor connector and sub fan relay terminal. <i>Connector & terminal</i> <i>(F16) No. 2 — (F27) No. 20:</i>	Is the resistance less than 1 Ω ?	Go to step 28 .	Repair the open circuit in harness between sub fan motor connector and sub fan relay terminal.
28 CHECK HARNESS BETWEEN SUB FAN RELAY AND ECM. 1) Turn the ignition switch to OFF. 2) Disconnect the connector from ECM. 3) Measure the resistance of harness between sub fan relay connector and ECM connector. <i>Connector & terminal</i> <i>(F27) No. 22 — (B136) No. 29:</i>	Is the resistance less than 1 Ω ?	Go to step 29 .	Repair the open circuit in harness between sub fan relay and ECM.
29 CHECK POOR CONTACT. Check poor contact in connector between sub fan and ECM.	Is there poor contact in connector between sub fan motor and ECM?	Repair the poor contact connector.	Record the DTC. Repair the trouble cause. <Ref. to EN(H4SO)(diag)-35, Read Diagnostic Trouble Code (DTC).>

4. Engine Coolant

A: REPLACEMENT

1. DRAINING OF ENGINE COOLANT

- 1) Lift-up the vehicle.
- 2) Remove the under cover.
- 3) Remove the drain plug to drain engine coolant into container.

NOTE:

- Remove the radiator cap so that engine coolant will drain faster.
- If engine coolant adheres to the exhaust pipe, wipe it off completely.

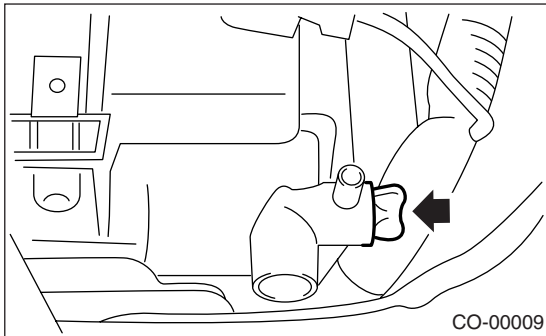

- 4) Install the drain plug.

2. FILLING OF ENGINE COOLANT

- 1) Pour cooling system conditioner through the filler neck.

Cooling system protective agent:

COOLING SYSTEM CONDITIONER (Part No. SOA635071)

- 2) Fill engine coolant into the radiator up to filler neck position.

Coolant capacity (fill up to "FULL" level):

AT model:

Approx. 6.9 ℓ (7.3 US qt, 6.1 Imp qt)

MT model:

Approx. 7.0 ℓ (7.4 US qt, 6.2 Imp qt)

NOTE:

The SUBARU Genuine Coolant containing anti-freeze and anti-rust agents is especially made for SUBARU engine, which has an aluminum crankcase. Always use SUBARU Genuine Coolant, since other coolant may cause corrosion.

- 3) Fill engine coolant into the reservoir tank up to "FULL" level.

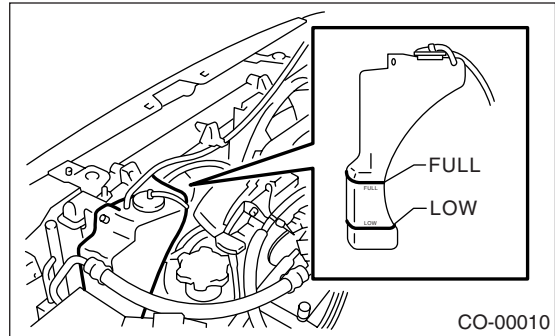

- 4) Close the radiator cap and start the engine. Race 5 to 6 times at less than 3,000 rpm, then stop the engine. (Complete this operation within 40 seconds.)
- 5) Wait for one minute after the engine stops, open the radiator cap. If the engine coolant level drops, add engine coolant into radiator up to the filler neck position.
- 6) Perform the procedures 4) and 5) again.
- 7) Attach the radiator cap and reservoir tank cap properly.
- 8) Start the engine and operate the heater at maximum hot position and the blower speed setting to "LO".
- 9) Run the engine at 2,000 rpm or less until radiator fan starts and stops.

NOTE:

- Be careful with the engine coolant temperature gauge to prevent overheating.
 - If the radiator hose becomes to harden by the pressure of engine coolant, air bleeding operation seems to be almost completed.
- 10) Stop the engine and wait until engine coolant temperature lowers to 30°C (86°F).
 - 11) Open the radiator cap. If the engine coolant level drops, add engine coolant into radiator up to the filler neck position and reservoir tank to "FULL" level.
 - 12) Attach the radiator cap and reservoir tank cap properly.
 - 13) Operate the heater at maximum hot position and the blower speed setting to "LO" and start the engine. Race at less than 3,000 rpm. If the flowing sound is heard at this time, perform the procedures from 9) again.

B: INSPECTION

1. RELATIONSHIP OF SUBARU COOLANT CONCENTRATION AND FREEZING TEMPERATURE

The concentration and safe operating temperature of the SUBARU coolant is shown in the diagram. Measuring the temperature and specific gravity of the coolant will provide this information.

[Example]

If the coolant temperature is 25°C (77°F) and its specific gravity is 1.054 and the concentration is 35% (point A), the safe operating temperature is -14°C (7°F) (point B), and the freezing temperature is -20°C (-4°F) (point C).

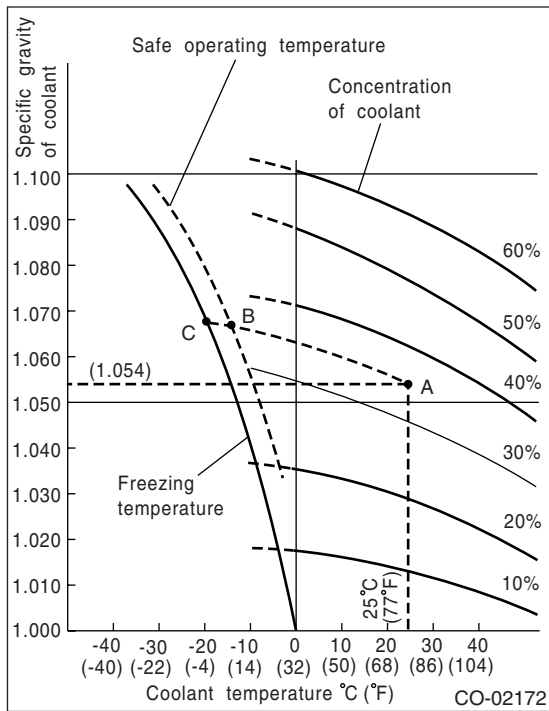

2. PROCEDURE TO ADJUST THE CONCENTRATION OF THE COOLANT

To adjust the concentration of the coolant according to temperature, find the proper fluid concentration in the above diagram and replace the necessary amount of coolant with an undiluted solution of SUBARU genuine coolant (concentration 50%).

The amount of coolant that should be replaced can be determined using the diagram.

[Example]

Assume that the coolant concentration must be increased from 25% to 40%. Find point A, where the 25% line of coolant concentration intersects with the 40% curve of the necessary coolant concentration, and read the scale on the vertical axis of the graph at height A. The quantity of coolant to be drained is 2.1 ℓ (2.2 US qt, 1.8 Imp qt). Drain 2.1 ℓ (2.2 US qt, 1.8 Imp qt) of coolant from the cooling system and add 2.1 ℓ (2.2 US qt, 1.8 Imp qt) of the undiluted solution of SUBARU coolant.

If a coolant concentration of 50% is needed, drain all the coolant and refill with the undiluted solution only.

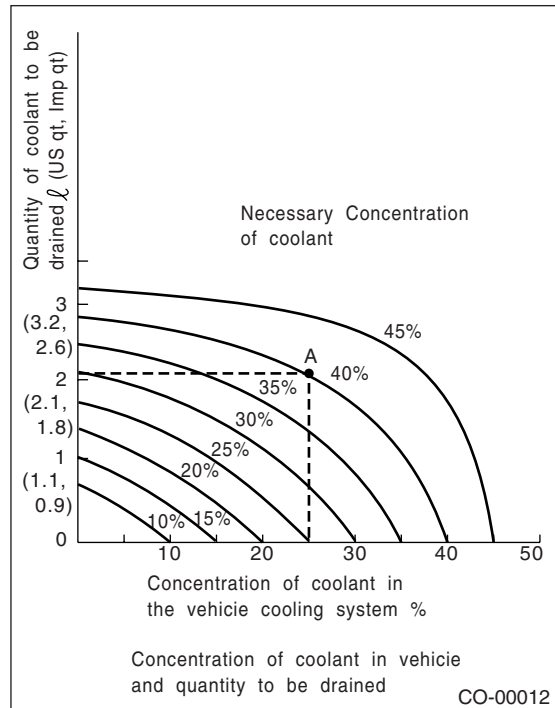

Water Pump

COOLING

5. Water Pump

A: REMOVAL

- 1) Remove the radiator. <Ref. to CO(H4SO)-23, REMOVAL, Radiator.>
- 2) Remove the V-belts.
<Ref. to ME(H4SO)-40, REMOVAL, V-belt.>
- 3) Remove the crank pulley.
<Ref. to ME(H4SO)-42, REMOVAL, Crank Pulley.>
- 4) Remove the timing belt.
<Ref. to ME(H4SO)-44, TIMING BELT, REMOVAL, Timing Belt.>
- 5) Remove the automatic belt tension adjuster.

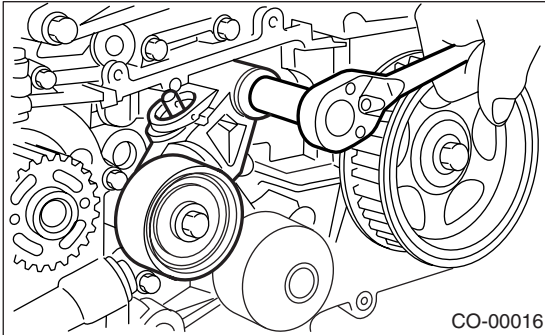

- 6) Remove the belt idler No. 2.

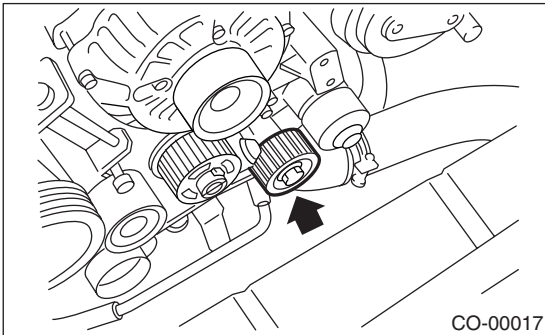

- 7) Remove the cam sprocket (LH) by using ST.
ST 18231AA010 CAM SPROCKET WRENCH

NOTE:

Also the CAM SPROCKET WRENCH (499207100) can be used.

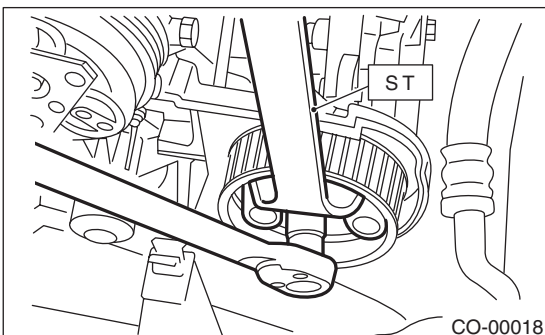

- 8) Remove the belt cover No. 2 (LH).

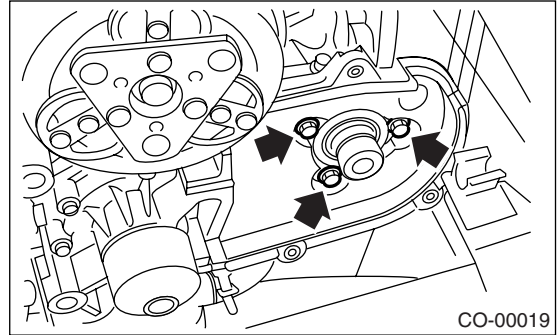

- 9) Remove the tensioner bracket.

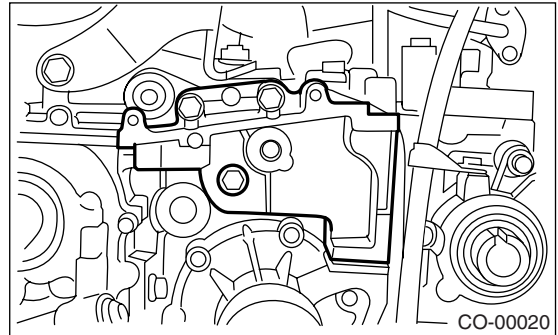

- 10) Disconnect the hose from water pump.
- 11) Remove the water pump.

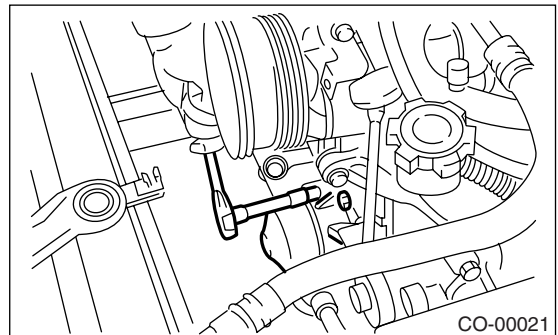

B: INSTALLATION

- 1) Install the water pump onto cylinder block (LH).

NOTE:

- Replace the gasket with a new one.
- When installing the water pump, tighten the bolts in two stages in alphabetical sequence as shown in the figure.

Tightening torque:

First:

12 N·m (1.2 kgf·m, 8.7 ft·lb)

Second:

12 N·m (1.2 kgf·m, 8.7 ft·lb)

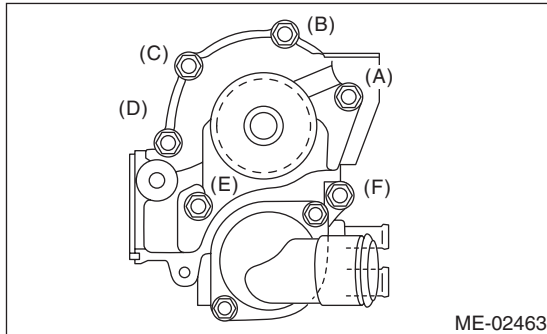

- 2) Connect the hose to water pump.
- 3) Install the tensioner bracket.

Tightening torque:

24.5 N·m (2.5 kgf·m, 18.1 ft·lb)

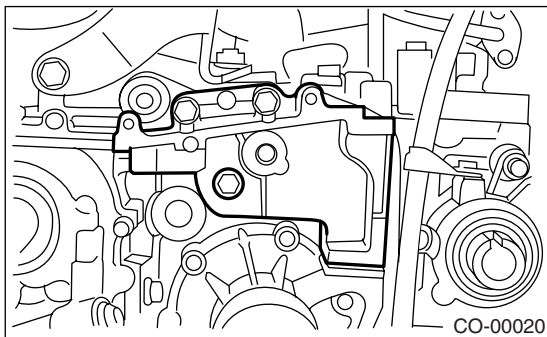

- 4) Install the belt cover No. 2 (LH).

Tightening torque:

5 N·m (0.5 kgf·m, 3.6 ft·lb)

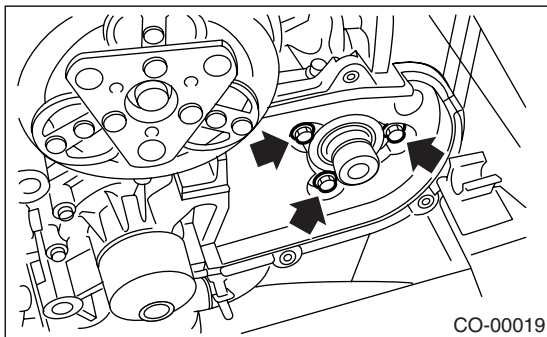

- 5) Install the cam sprockets (LH) by using ST.
ST 18231AA010 CAM SPROCKET WRENCH

NOTE:

Also the CAM SPROCKET WRENCH (499207100) can be used.

Tightening torque:

78 N·m (8.0 kgf·m, 57.9 ft·lb)

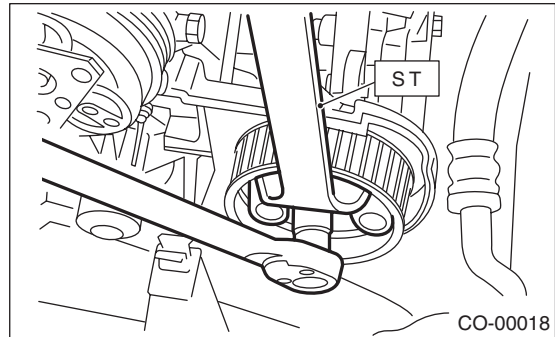

- 6) Install the belt idler No. 2.

Tightening torque:

39 N·m (4.0 kgf·m, 28.9 ft·lb)

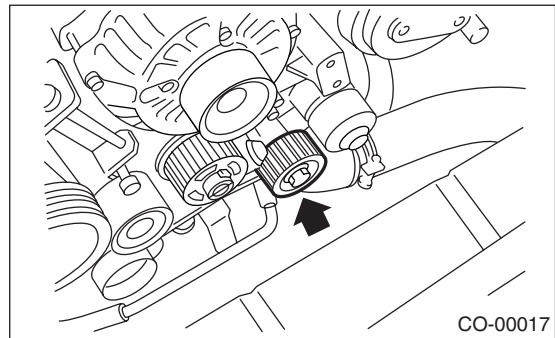

- 7) Install the automatic belt tension adjuster whose tension rod is held with pin. <Ref. to ME(H4SO)-45, AUTOMATIC BELT TENSION ADJUSTER ASSEMBLY AND BELT IDLER, INSTALLATION, Timing Belt.>
- 8) Install the timing belt. <Ref. to ME(H4SO)-46, TIMING BELT, INSTALLATION, Timing Belt.>
- 9) Install the crank pulley. <Ref. to ME(H4SO)-42, INSTALLATION, Crank Pulley.>
- 10) Install the V-belts. <Ref. to ME(H4SO)-40, INSTALLATION, V-belt.>
- 11) Install the radiator. <Ref. to CO(H4SO)-24, INSTALLATION, Radiator.>

C: INSPECTION

- 1) Check the water pump bearing for smooth rotation.
- 2) Check the water pump pulley for abnormalities.
- 3) Check the impeller for damage or abnormal deformation.
- 4) Check the clearance between impeller and pump case.

Water Pump

COOLING

Clearance between impeller and pump case:

Standard

0.5 — 1.5 mm (0.020 — 0.060 in)

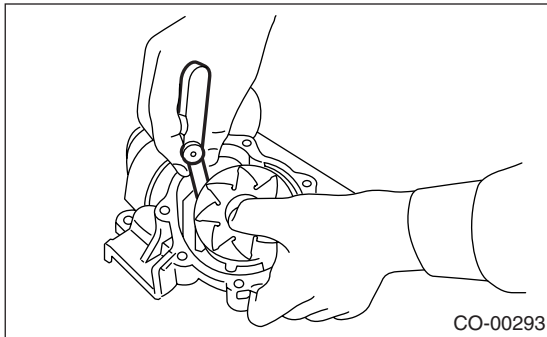

5) After water pump installation, check the pulley shaft for engine coolant leaks. If leaks are noted, replace the water pump assembly.

6. Thermostat

A: REMOVAL

- 1) Set the vehicle on a lift.
- 2) Lift-up the vehicle.
- 3) Remove the under cover.
- 4) Drain the engine coolant completely. <Ref. to CO(H4SO)-16, DRAINING OF ENGINE COOLANT, REPLACEMENT, Engine Coolant.>

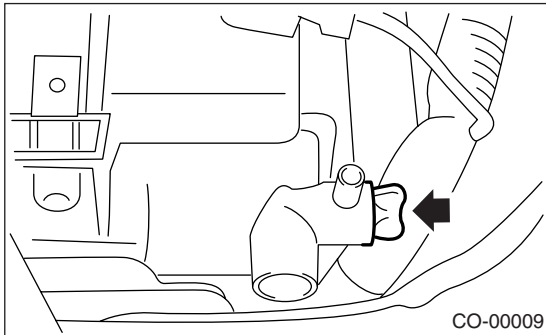

- 5) Disconnect the radiator outlet hose from thermostat cover.

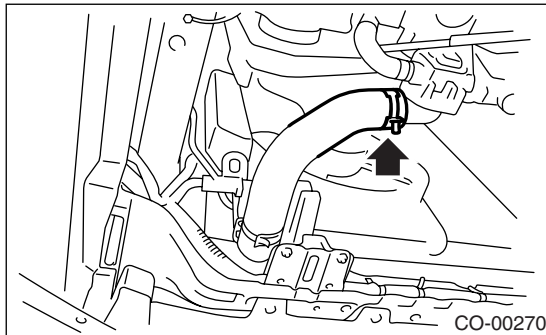

- 6) Remove the thermostat cover, and then remove the gasket and thermostat.

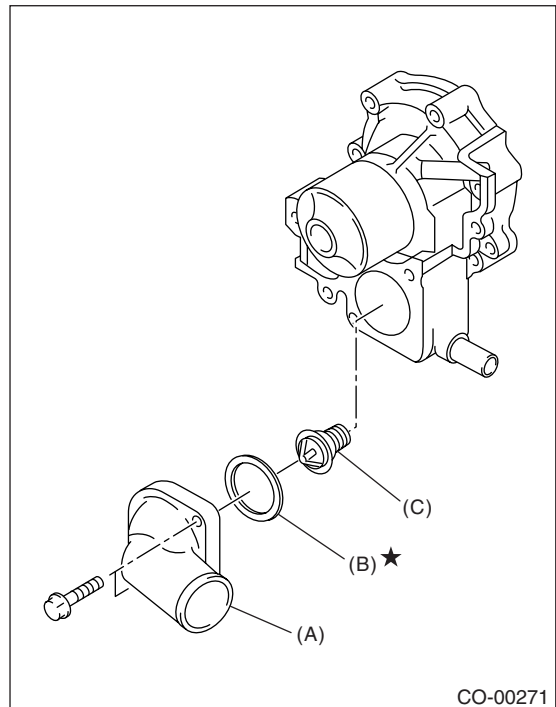

- (A) Thermostat cover
- (B) Gasket
- (C) Thermostat

B: INSTALLATION

- 1) Install a gasket to thermostat, and install the thermostat and gasket to water pump as a unit. Then, install the thermostat cover.

NOTE:

- When reinstalling the thermostat, use a new gasket.
- The thermostat must be installed with the jiggle pin facing to the up side.

Thermostat

COOLING

Tightening torque:

12 N·m (1.2 kgf·m, 8.7 ft·lb)

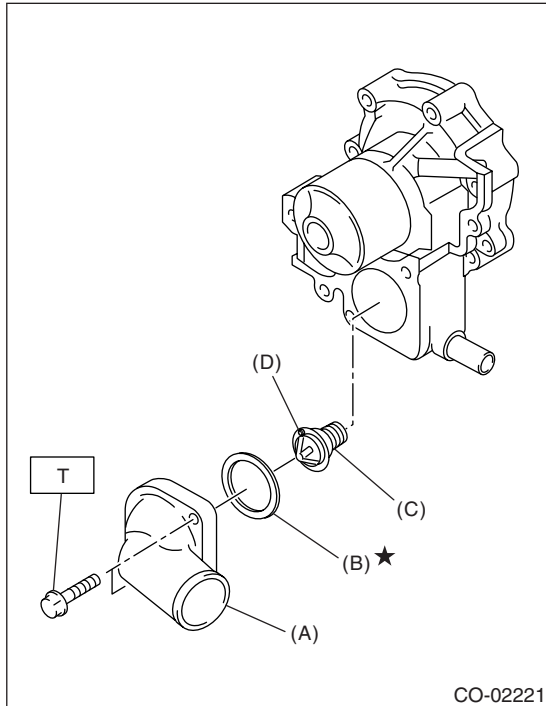

- (A) Thermostat cover
- (B) Gasket
- (C) Thermostat
- (D) Jiggle pin

- 2) Connect the radiator outlet hose to thermostat cover.
- 3) Install the under cover.
- 4) Lower the vehicle.
- 5) Fill with engine coolant. <Ref. to CO(H4SO)-16, FILLING OF ENGINE COOLANT, REPLACEMENT, Engine Coolant.>

C: INSPECTION

Replace the thermostat if the valve does not close completely at an ambient temperature or if the following test shows unsatisfactory results.

• Inspection method

Immerse the thermostat and a thermometer in water. Raise water temperature gradually, and measure the temperature and valve lift when the valve begins to open and when the valve is fully opened. During the test, agitate the water for even temperature distribution. The measured value should meet the specification.

NOTE:

- Leave the thermostat in the boiling water for more than five minutes before measuring the valve lift.
- Hold the thermostat with a wire or the like to avoid contacting with container bottom.

Starting temperature to open:

80 — 84°C (176 — 183°F)

Fully opens:

95°C (203°F)

Valve lift:

9.0 mm (0.354 in) or more.

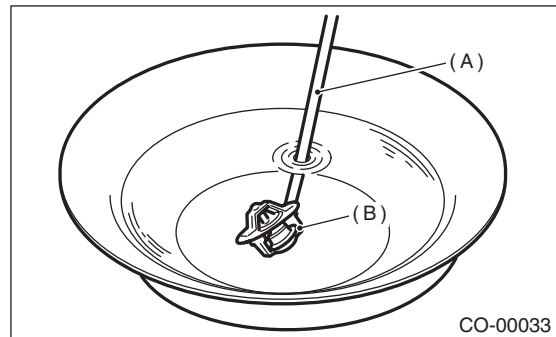

- (A) Thermometer
- (B) Thermostat

7. Radiator

A: REMOVAL

- 1) Set the vehicle on a lift.
- 2) Disconnect the ground cable from battery.
- 3) Lift-up the vehicle.
- 4) Remove the under cover.
- 5) Drain the engine coolant completely. <Ref. to CO(H4SO)-16, DRAINING OF ENGINE COOLANT, REPLACEMENT, Engine Coolant.>
- 6) Disconnect the connectors of radiator main fan motor (A) and sub fan motor (B).

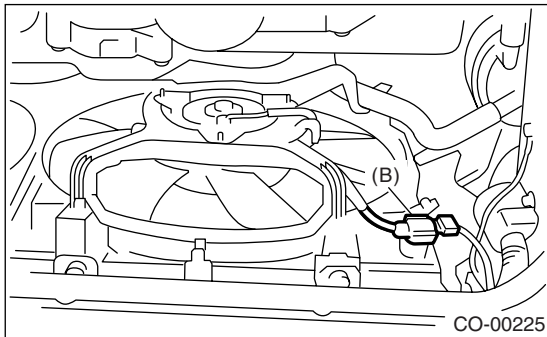
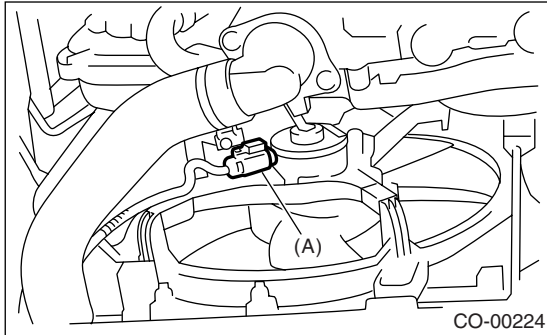

- 7) Disconnect the radiator outlet hose from water pump.

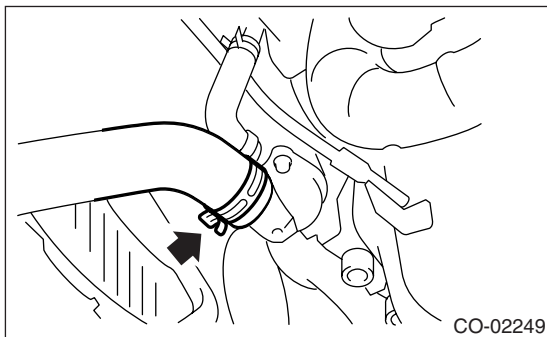

- 8) Disconnect the ATF cooler hoses from ATF pipe. (AT model) Plug the openings in the hose and radiator with caps in order to prevent ATF from leaking.

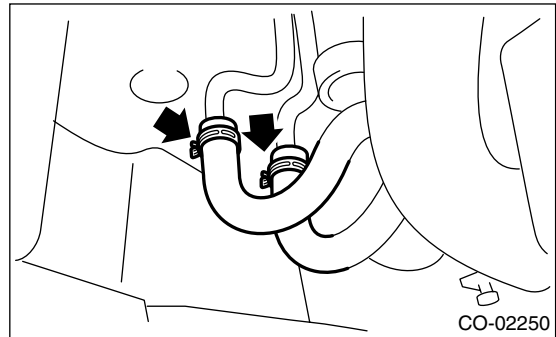

- 9) Lower the vehicle.
- 10) Disconnect the overflow hose.
- 11) Remove the reservoir tank. <Ref. to CO(H4SO)-29, REMOVAL, Reservoir Tank.>
- 12) Remove the air intake duct.
- 13) Disconnect the radiator inlet hose from engine.

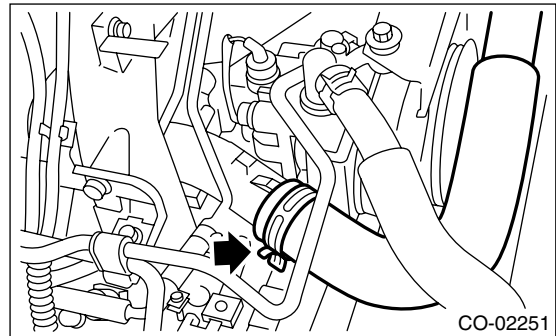

- 14) Remove the radiator upper brackets.

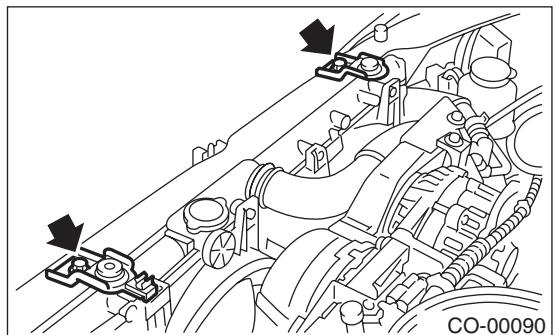

- 15) Detach the power steering hose from clip on radiator.

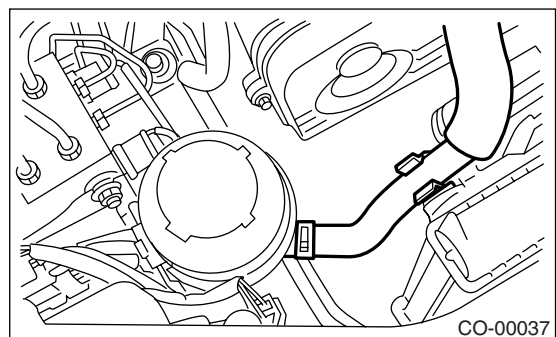

Radiator

COOLING

16) Lift the radiator up and away from the vehicle.

B: INSTALLATION

1) Attach the radiator lower cushions to holes on the radiator lower bracket.

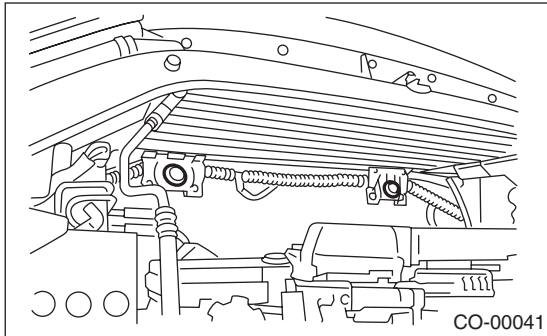

2) Install the radiator to vehicle.

NOTE:

Fit the pins on lower side of radiator into the cushions on the body side.

3) Install the radiator upper brackets, and then tighten the bolts.

Tightening torque:

18 N·m (1.8 kgf-m, 13.0 ft-lb)

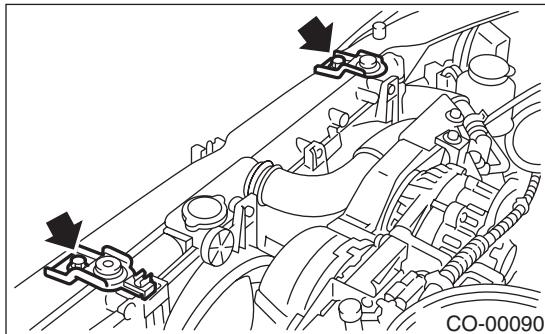

4) Attach the power steering hose to radiator.

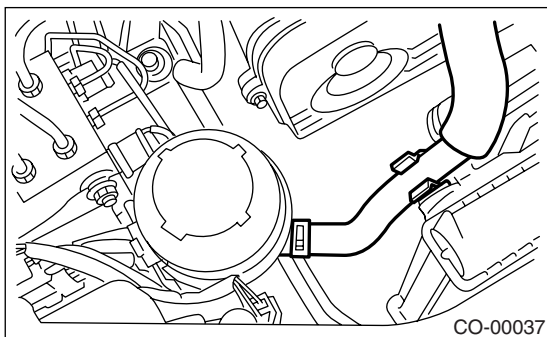

5) Connect the radiator inlet hose.

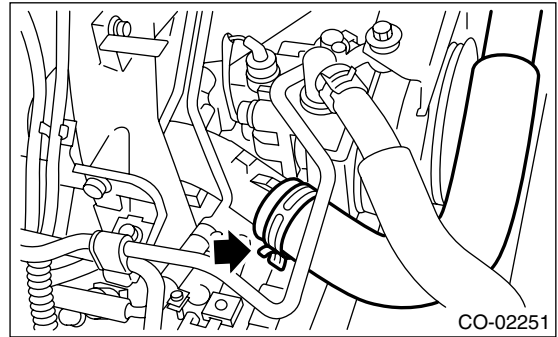

6) Install the air intake duct.

7) Install the reservoir tank.

8) Connect the overflow hose.

9) Lift-up the vehicle.

10) Connect the ATF cooler hoses. (AT model)

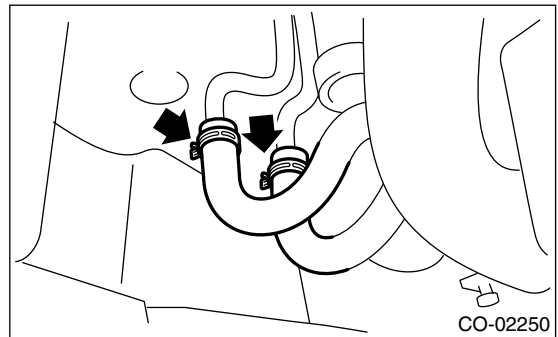

11) Connect the radiator outlet hose.

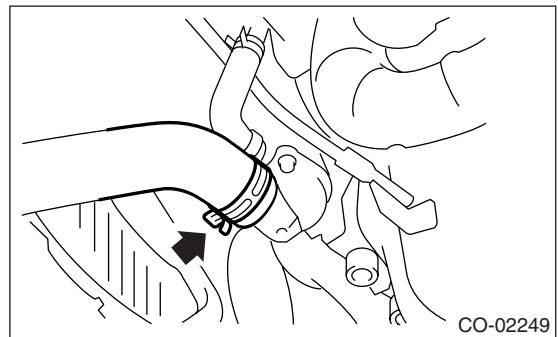

12) Connect the connectors to radiator main fan motor (A) and sub fan motor (B).

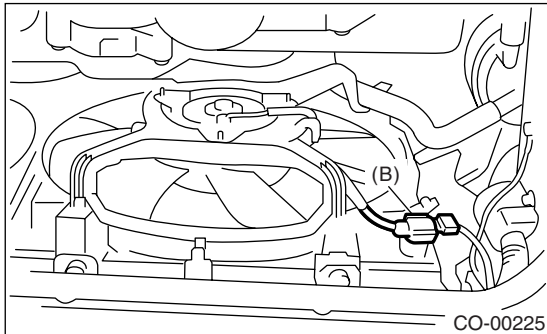
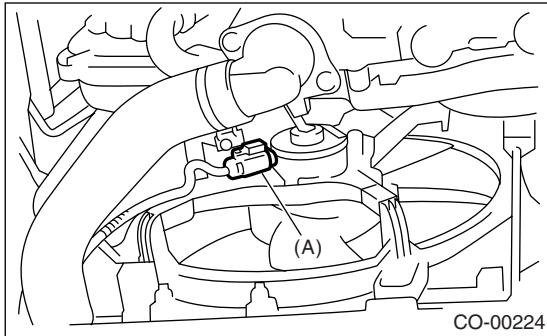

- If engine coolant adheres to the exhaust pipe, wipe it off completely.
- Be careful to prevent engine coolant from spurting out when removing the tester.
- Be careful also not to deform the filler neck of radiator when installing or removing tester.

13) Install the under cover.

14) Lower the vehicle.

15) Connect the battery ground cable to battery.

16) Fill engine coolant. <Ref. to CO(H4SO)-16, FILLING OF ENGINE COOLANT, REPLACEMENT, Engine Coolant.>

17) Check the ATF level. <Ref. to 4AT-30, INSPECTION, Automatic Transmission Fluid.>

C: INSPECTION

1) Remove the radiator cap, top off radiator, and then attach the tester to radiator in place of cap.

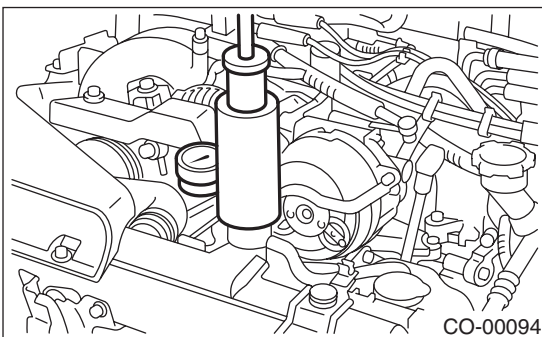

2) Apply a pressure of 157 kPa (1.6 kgf/cm², 23 psi) to the radiator in the follow cases.

- (1) Engine coolant leaks at/around radiator.
- (2) Engine coolant leaks at/around hoses or connections.

CAUTION:

- Engine should be turned off.
- Wipe engine coolant from check points in advance.

8. Radiator Cap

A: INSPECTION

1) Attach the radiator cap to tester.

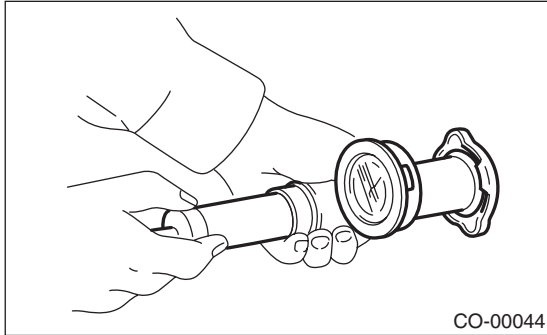

2) Increase the pressure until tester gauge pointer stops. Radiator cap is functioning properly if it holds the service limit pressure for 5 to 6 seconds.

Standard pressure:

93 — 123 kPa (0.95 — 1.25 kgf/cm², 14 — 18 psi)

Service limit pressure:

83 kPa (0.85 kgf/cm², 12 psi)

CAUTION:

Be sure to remove foreign matter and rust from the cap in advance. Otherwise, results of pressure test will be incorrect.

9. Radiator Main Fan and Fan Motor

A: REMOVAL

- 1) Set the vehicle on a lift.
- 2) Disconnect the ground cable from battery.
- 3) Lift-up the vehicle.
- 4) Remove the under cover.
- 5) Disconnect the connector of main fan motor (A).

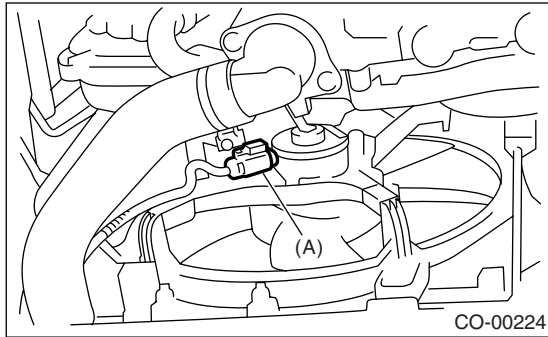

- 6) Remove the ATF hose from clip of radiator main fan motor assembly. (AT model)
- 7) Lower the vehicle.
- 8) Disconnect the overflow hose.
- 9) Remove the reservoir tank. <Ref. to CO(H4SO)-29, REMOVAL, Reservoir Tank.>
- 10) Remove the bolts which secure the radiator main fan shroud to radiator.

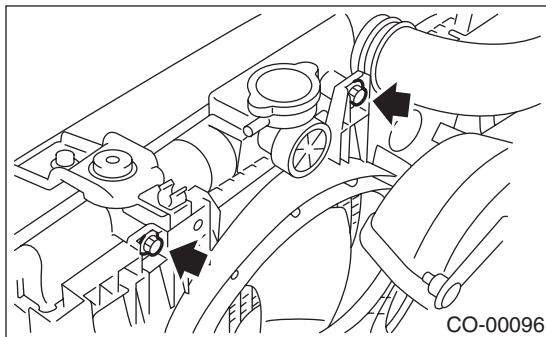

- 11) Remove the radiator fan motor assembly.

B: INSTALLATION

Install in the reverse order of removal.

NOTE:

- If it is difficult to install the radiator main fan motor assembly, first loosen the bolts which hold the radiator sub fan motor assembly.
- Refer to COMPONENT for tightening torque. <Ref. to CO(H4SO)-3, COMPONENT, General Description.>

C: DISASSEMBLY

- 1) Remove the nut which holds the fan onto fan motor.

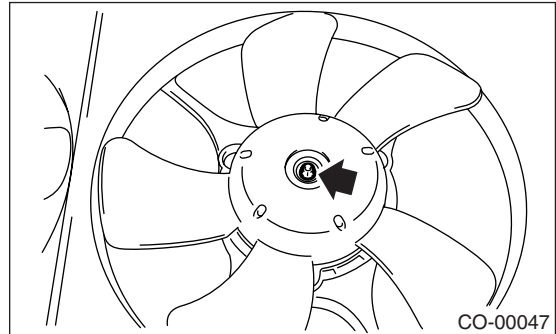

- 2) Remove the bolts which install the fan motor onto shroud.

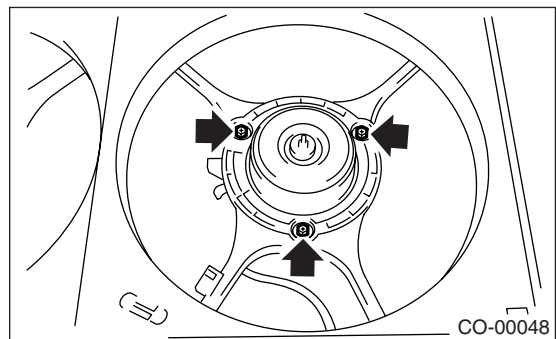

D: ASSEMBLY

Assemble in the reverse order of disassembly.

Tightening torque:

4.4 N-m (0.45 kgf-m, 3.3 ft-lb)

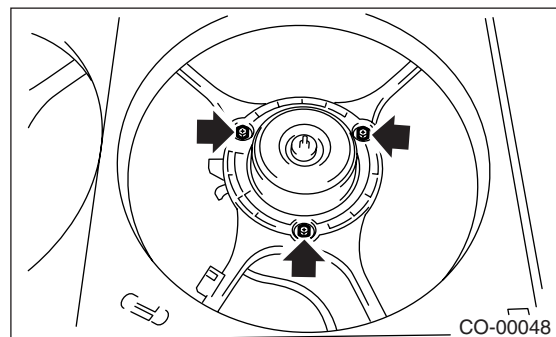

Tightening torque:

3.4 N-m (0.35 kgf-m, 2.5 ft-lb)

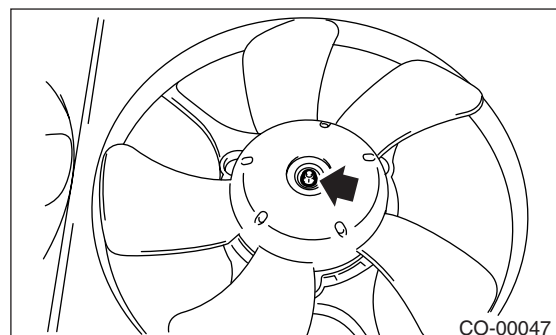

Radiator Sub Fan and Fan Motor

COOLING

10. Radiator Sub Fan and Fan Motor

A: REMOVAL

- 1) Set the vehicle on a lift.
- 2) Disconnect the ground cable from battery.
- 3) Lift-up the vehicle.
- 4) Remove the under cover.
- 5) Disconnect the connector of sub fan motor (B).

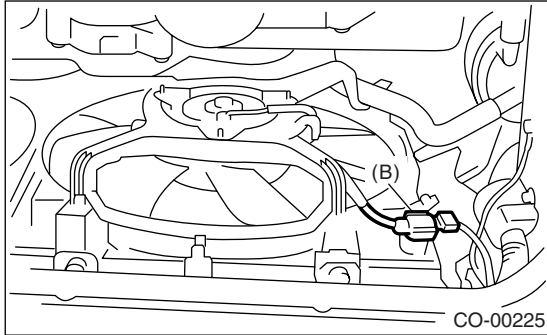

- 6) Remove the ATF hose from clips of radiator sub fan motor assembly. (AT model)
- 7) Lower the vehicle.
- 8) Remove the air intake duct.
- 9) Remove the bolts which hold the radiator sub fan shroud to radiator.

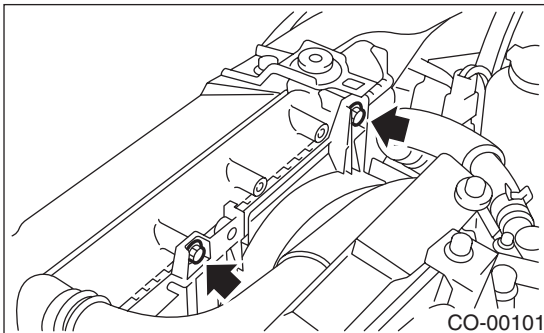

- 10) Remove the radiator sub fan motor assembly through the under side of vehicle.

B: INSTALLATION

Install in the reverse order of removal.

NOTE:

Refer to COMPONENT for tightening torque. <Ref. to CO(H4SO)-3, COMPONENT, General Description.>

C: DISASSEMBLY

- 1) Remove the clip which holds the motor connector onto shroud.

- 2) Remove the nut which holds the fan onto fan motor.

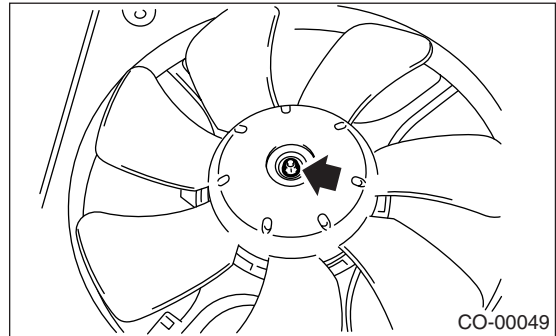

- 3) Remove the bolts which install the fan motor onto shroud.

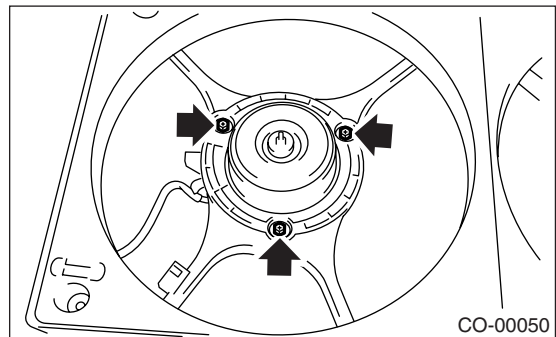

D: ASSEMBLY

Assemble in the reverse order of disassembly.

Tightening torque:

4.4 N-m (0.45 kgf-m, 3.3 ft-lb)

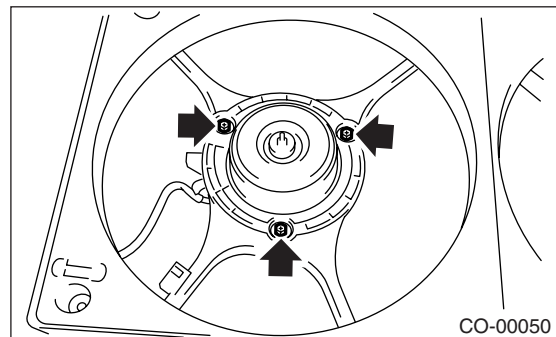

Tightening torque:

3.4 N-m (0.35 kgf-m, 2.5 ft-lb)

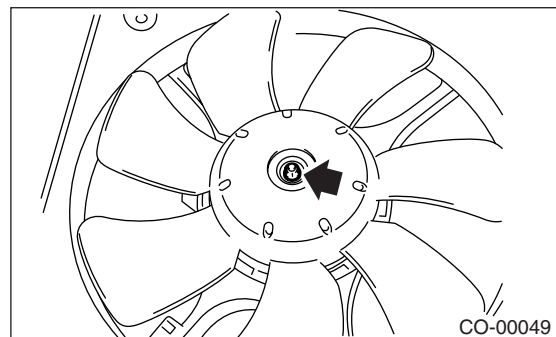

11. Reservoir Tank

A: REMOVAL

- 1) Disconnect the overflow hose from the radiator filler neck position.
- 2) While pressing the pawl (A), remove the reservoir tank by pulling in the direction of arrow.

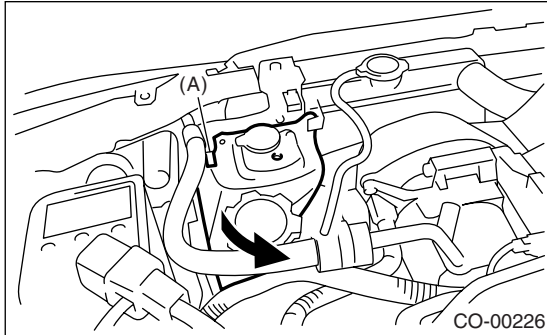

B: INSTALLATION

Install in the reverse order of removal.

C: INSPECTION

Make sure the engine coolant level is between "FULL" and "LOW".

Engine Cooling System Trouble in General

COOLING

12.Engine Cooling System Trouble in General

A: INSPECTION

Trouble	Possible cause	Corrective action
Over-heating	a. Insufficient engine coolant	Replenish the engine coolant, inspect for leakage, and repair.
	b. Loose timing belt	Repair or replace the timing belt tensioner.
	c. Oil on timing belt	Replace.
	d. Malfunction of thermostat	Replace.
	e. Malfunction of water pump	Replace.
	f. Clogged engine coolant passage	Clean.
	g. Improper ignition timing	Inspect and repair the ignition control system. <Ref. to EN(H4SO)(diag)-2, Basic Diagnostic Procedure.>
	h. Clogged or leaking radiator	Clean or repair, or replace.
	i. Improper engine oil in engine coolant	Replace the engine coolant.
	j. Air/fuel mixture ratio too lean	Inspect and repair the fuel injection system. <Ref. to EN(H4SO)(diag)-2, Basic Diagnostic Procedure.>
	k. Excessive back pressure in exhaust system	Clean or replace.
	l. Insufficient clearance between piston and cylinder	Adjust or replace.
	m. Slipping clutch	Repair or replace.
n. Dragging brake	Adjust.	
o. Malfunction of radiator fan	Inspect the radiator fan relay, engine coolant temperature sensor or radiator motor and replace them.	
Over-cooling	a. Atmospheric temperature extremely low	Partly cover the radiator front area.
	b. Defective thermostat	Replace.
Engine coolant leaks	a. Loosened or damaged connecting units on hoses	Repair or replace.
	b. Leakage from water pump	Replace.
	c. Leakage from water pipe	Repair or replace.
	d. Leakage around cylinder head gasket	Retighten the cylinder head bolts or replace gasket.
	e. Damaged or cracked cylinder head and cylinder block	Repair or replace.
	f. Damaged or cracked thermostat case	Repair or replace.
	g. Leakage from radiator	Repair or replace.
Noise	a. Defective timing belt	Replace.
	b. Defective radiator fan	Replace.
	c. Defective water pump bearing	Replace the water pump.
	d. Defective water pump mechanical seal	Replace the water pump.