

WHEEL AND TIRE SYSTEM

General Description

WHEEL AND TIRE SYSTEM

1. General Description

A: SPECIFICATION

1. WHEEL AND TIRE SIZE

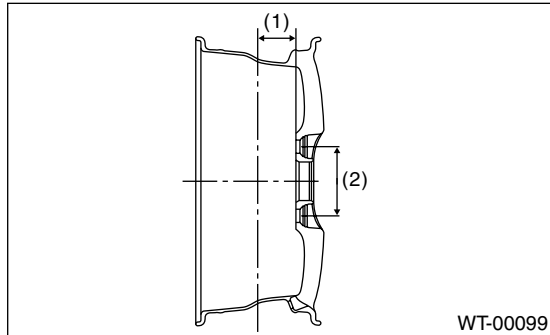

(1) Offset

(2) P.C.D.

Specification	Tire size	Wheel size	Offset mm (in)	P.C.D. mm (in)	Tire inflation pressure kPa (kgf/cm ² , psi)		
					Front wheel	Rear wheel	
2.5i, OUTBACK	205/55R16 89V	16×6 1/2JJ	55 (2.17)	100 (3.94)	230 (2.3, 33)	210 (2.1, 30)	
WRX	215/45R17 91W	17 × 7JJ	55 (2.17)		230 (2.3, 33)	220 (2.2, 32)	
STI	225/45R17 90W	17 × 8JJ	53 (2.09)	114.3 (4.50)	250 (2.5, 36)	210 (2.1, 30)	
"T-type" Tire	2.5i, OUTBACK, WRX	T135/70D16 100M	16 × 4T	50 (1.97)	100 (3.94)	420 (4.2, 60)	
	STI	T135/70D17 102M	17 × 4T	40 (1.57)	114.3 (4.50)		

NOTE:

"T-type" tire for temporary use is supplied as a spare tire.

General Description

WHEEL AND TIRE SYSTEM

2. SERVICE DATA

Item	Axial runout	Radial runout
Aluminum wheel	1.0 mm (0.039 in)	

3. ADJUSTING PARTS

Wheel balance	Standard	Service limit
Dynamic unbalance	Less than 5 g (0.18 oz)	

Balance weight part number (Knock-on type weight for aluminum wheel)	Weight
28101SA000	5 g (0.18 oz)
28101SA010	10 g (0.35 oz)
28101SA020	15 g (0.53 oz)
28101SA030	20 g (0.71 oz)
28101SA040	25 g (0.88 oz)
28101SA100	30 g (1.06 oz)
28101SA110	35 g (1.23 oz)
28101SA120	40 g (1.41 oz)
28101SA130	45 g (1.59 oz)
28101SA140	50 g (1.76 oz)
—	55 g (1.94 oz)
28101SA150	60 g (2.12 oz)

Balance weight part number (Adhesive type weight for aluminum wheel)	Weight
28101AG001	5 g (0.18 oz)
28101AG011	7.5 g (0.26 oz)
28101AG021	10 g (0.35 oz)
28101AG031	12.5 g (0.44 oz)
28101AG041	15 g (0.53 oz)
28101AG051	17.5 g (0.62 oz)
28101AG061	20 g (0.71 oz)
28101AG071	22.5 g (0.79 oz)
28101AG081	25 g (0.88 oz)
28101AG091	27.5 g (0.97 oz)
28101AG101	30 g (1.06 oz)
28101AG111	32.5 g (1.15 oz)
28101AG121	35 g (1.23 oz)
28101AG131	37.5 g (1.32 oz)
28101AG141	40 g (1.41 oz)
28101AG151	42.5 g (1.50 oz)
28101AG161	45 g (1.59 oz)
28101AG171	47.5 g (1.68 oz)
28101AG181	50 g (1.76 oz)
28101AG191	52.5 g (1.85 oz)
28101AG201	55 g (1.94 oz)
28101AG211	57.5 g (2.03 oz)
28101AG221	60 g (2.12 oz)
28101AG231	62.5 g (2.20 oz)
28101AG241	65 g (2.29 oz)

Balance weight part number (Adhesive type weight for aluminum wheel)	Weight
28101AG251	67.5 g (2.38 oz)
28101AG261	70 g (2.47 oz)
28101AG271	72.5 g (2.56 oz)
28101AG281	75 g (2.65 oz)
28101AG291	77.5 g (2.73 oz)
28101AG301	80 g (2.82 oz)
28101AG311	82.5 g (2.91 oz)
28101AG321	85 g (3.00 oz)
28101AG331	87.5 g (3.09 oz)
28101AG341	90 g (3.17 oz)
28101AG351	92.5 g (3.26 oz)
28101AG361	95 g (3.35 oz)
28101AG371	97.5 g (3.44 oz)
28101AG381	100 g (3.53 oz)

B: PREPARATION TOOL

1. GENERAL TOOL

TOOL NAME	REMARKS
Air pressure gauge	Used for measuring tire air pressure.
Dial gauge	Used for measuring wheel runout.
Wheel balancer	Used for adjusting wheel balance.

2. Tire

A: INSPECTION

- 1) Take stone, glass, nail etc. off from tread groove.
- 2) Replace the tire if as follows.

CAUTION:

When replacing a tire, make sure to use only the same size, construction and load range tire as originally installed.

- (1) When a large crack on the side wall, damage or a crack on tread are found.
- (2) When the "tread wear indicator" appears as a solid band across the tread.

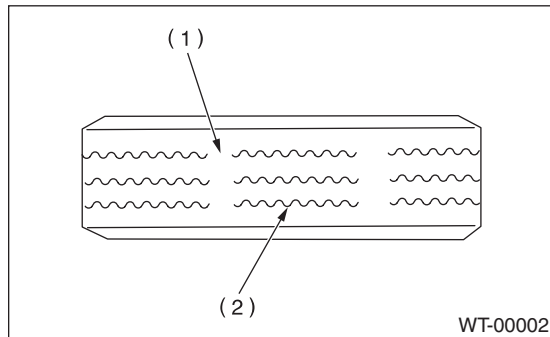

- (1) Tread wear indicator
- (2) Tire tread

- 3) When a crack on tire valve is found, replace the tire valve.

1. TIRE ROTATION

Rotate tires periodically (12,500 km/7,500 miles) as shown in the figure, in order to prevent them from uneven wear and to prolong their life.

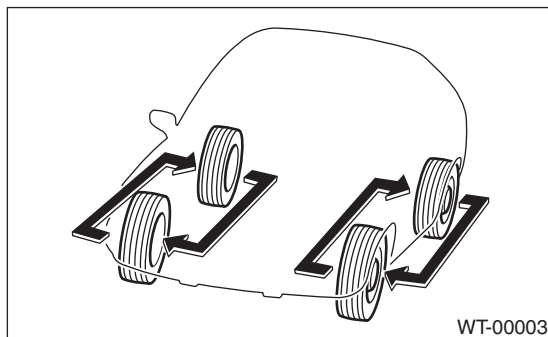

3. Aluminum Wheel

A: REMOVAL

- 1) Apply parking brake, and position the select lever or shift lever to "P" range (AT model) or "1st gear" (MT model).
- 2) Set jacks or a lift to the specified point, and support the vehicle with its tires slightly contacting the floor.
- 3) Loosen the wheel nuts.
- 4) Raise the vehicle until its tires take off the ground using a jack or a lift.
- 5) Remove the wheel nuts and wheels.

NOTE:

- While removing the wheels, prevent the hub bolts from damage.
- Place the wheels with their outer sides facing upward to prevent the wheels from damage.

B: INSTALLATION

- 1) Remove dirt from the mating surface of wheel and brake rotor.
- 2) Attach the wheel to hub by aligning the wheel bolt hole with hub bolt.
- 3) Temporarily attach the wheel nuts to hub bolts, using SUBARU genuine wheel nut.
- 4) Manually tighten the nuts making sure the wheel hub hole is aligned correctly to guide portion of hub.
- 5) Tighten the wheel nuts in a diagonal selection to specified torque. Use a wheel nut wrench.

Wheel nut tightening torque:

90 N·m (9.1 kgf·m, 65.7 ft·lb)

CAUTION:

- **Tighten the wheel nuts in two or three steps by gradually increasing the torque and working diagonally, until the specified torque is reached.**
- **Do not depress the wrench with foot; Always use both hands when tightening.**
- **Make sure the bolt, nut and nut seating surface of the wheel are free from oils.**

6) If a wheel is removed for replacement or for repair of a puncture, retighten the wheel nuts to the specified torque after running 1,000 km (600 miles).

C: INSPECTION

- 1) Deformation or damage on the rim can cause air leakage. Check the rim flange for deformation, crack or damage, and repair or replace as necessary.
- 2) Jack-up the vehicle until tires clear the floor.

3) Slowly rotate the wheel to check the rim "runout" using a dial gauge.

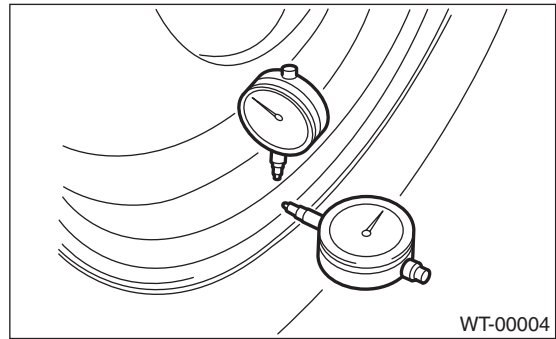

Axial runout limit	Radial runout limit
1.0 mm (0.039 in)	

4) If the rim runout exceeds specifications, remove the tire from rim and check runout while attaching the dial gauge to positions shown in the figure.

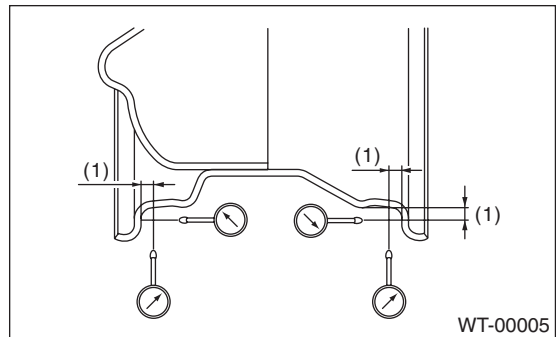

(1) Approx. 7 mm (0.28 in)

5) If the measured runout still exceeds specifications, replace the wheel.

D: CAUTION

Aluminum wheels are easily scratched. To maintain their appearance and safety, do the following:

- 1) Do not damage the aluminum wheels during removal, installation, wheel balancing, etc. After removing, place them on a rubber mat, etc.
- 2) While the vehicle is being driven, be careful not to ride over sharp obstacles or allow the wheels to contact the shoulder of road.
- 3) When installing a tire chain, be sure to install it properly not to have slack; otherwise it may hit the wheel while driving.
- 4) When washing the aluminum wheel, use neutral synthetic detergent and water. Avoid using the cleanser including abrasive, hard brushes or an automatic car washer.

Wheel Balancing

WHEEL AND TIRE SYSTEM

4. Wheel Balancing

A: REPLACEMENT

1. STICK-ON TYPE BALANCE WEIGHT

- 1) Remove balance weights.
- 2) Using dynamic balancing, measure wheel balance.
- 3) Select a weight close to the value measured by dynamic balancing.

Balance weight part number (Knock-on type weight for aluminum wheel)	Weight
28101SA000	5 g (0.18 oz)
28101SA010	10 g (0.35 oz)
28101SA020	15 g (0.53 oz)
28101SA030	20 g (0.71 oz)
28101SA040	25 g (0.88 oz)
28101SA100	30 g (1.06 oz)
28101SA110	35 g (1.23 oz)
28101SA120	40 g (1.41 oz)
28101SA130	45 g (1.59 oz)
28101SA140	50 g (1.76 oz)
—	55 g (1.94 oz)
28101SA150	60 g (2.12 oz)

- 4) Install the selected weight to the point designated by dynamic balancing.
- 5) Using dynamic balancing, measure wheel balance again. Check that wheel balance is correctly adjusted.

2. PASTE-ON TYPE BALANCE WEIGHT

- 1) Remove balance weights.
- 2) Remove traces of two-sided tape on wheel and clean adhesive layer.
- 3) Set balancing (dynamic balancing for stick-on balance weight is available) and measure wheel balance.

Balance weight part number (Adhesive type weight for aluminum wheel)	Weight
28101AG001	5 g (0.18 oz)
28101AG011	7.5 g (0.26 oz)
28101AG021	10 g (0.35 oz)
28101AG031	12.5 g (0.44 oz)
28101AG041	15 g (0.53 oz)
28101AG051	17.5 g (0.62 oz)
28101AG061	20 g (0.71 oz)
28101AG071	22.5 g (0.79 oz)
28101AG081	25 g (0.88 oz)
28101AG091	27.5 g (0.97 oz)
28101AG101	30 g (1.06 oz)
28101AG111	32.5 g (1.15 oz)

Balance weight part number (Adhesive type weight for aluminum wheel)	Weight
28101AG121	35 g (1.23 oz)
28101AG131	37.5 g (1.32 oz)
28101AG141	40 g (1.41 oz)
28101AG151	42.5 g (1.50 oz)
28101AG161	45 g (1.59 oz)
28101AG171	47.5 g (1.68 oz)
28101AG181	50 g (1.76 oz)
28101AG191	52.5 g (1.85 oz)
28101AG201	55 g (1.94 oz)
28101AG211	57.5 g (2.03 oz)
28101AG221	60 g (2.12 oz)
28101AG231	62.5 g (2.20 oz)
28101AG241	65 g (2.29 oz)
28101AG251	67.5 g (2.38 oz)
28101AG261	70 g (2.47 oz)
28101AG271	72.5 g (2.56 oz)
28101AG281	75 g (2.65 oz)
28101AG291	77.5 g (2.73 oz)
28101AG301	80 g (2.82 oz)
28101AG311	82.5 g (2.91 oz)
28101AG321	85 g (3.00 oz)
28101AG331	87.5 g (3.09 oz)
28101AG341	90 g (3.17 oz)
28101AG351	92.5 g (3.26 oz)
28101AG361	95 g (3.35 oz)
28101AG371	97.5 g (3.44 oz)
28101AG381	100 g (3.53 oz)

- 4) Select a weight close to the calculated value, clean the point designated by balancing and paste on the weight there.

CAUTION:

- Press on the weight for more than 2 seconds with a force of 25 N·m (2.6 kgf-m, 18 ft-lb) or more per 5 g (0.18 oz) to paste on.
- Adjust weight balance from outside first and then inside.
- The weight to be pasted on must be under 100 g (3.53 oz).

B: INSPECTION

- 1) Proper wheel balance may be lost if the tire is repaired or if it wears. Check the tire for dynamic balance, and repair as necessary.
- 2) To check for dynamic balance, use a dynamic balancer. Drive in the balance weight on both the top and rear sides of the rim.
- 3) Some types of balancer can cause damage to the wheel. Use an appropriate balancer when adjusting the wheel balance.

4) Use genuine balance weights.

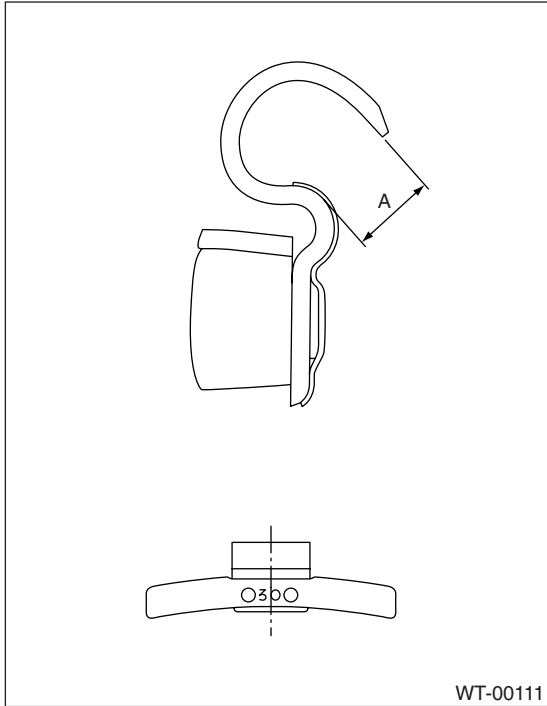

WT-00111

Service limit A:
5.0 mm (0.20 in)

5. “T-type” Tire

A: NOTE

“T-type” tire for temporary use is prepared as a spare tire.

CAUTION:

- Do not use a tire chain with the “T-type” tire. Because of the smaller tire size, a tire chain will not fit properly and will result in damage to the vehicle and the tire.
- Do not drive at a speed greater than 80 km/h (50 MPH).
- Drive as slowly as possible and avoid passing over bumps.

B: REPLACEMENT

Refer to Aluminum Wheel for removal and installation of “T-type” tires. <Ref. to WT-5, Aluminum Wheel.>

CAUTION:

Replace with a conventional tire as soon as possible since the “T-type” tire is only for temporary use.

C: INSPECTION

1) Check the tire inflation pressure.

Specification:

420 kPa (4.2 kgf/cm², 60 psi)

- 2) Take stones, glass, nails, etc. out of the tread groove.
- 3) Check the tires for deformation, cracks, partial or over limit wear.

CAUTION:

Replace the tire with a new one.

6. General Diagnostic Table

A: INSPECTION

Symptom	Possible cause	Remedy
Front wheel shimmy	Worn or improperly inflated tire.	In case of worn tire, replace the tire. In case of improperly inflated tire, adjust the tire air pressure properly.
	Wheel is out of balance.	Adjustment.
Abnormal tire wear	Improperly inflated tire.	Replace.
Sways/pitches	Worn or improperly inflated tire.	In case of worn tire, replace the tire. In case of improperly inflated tire, adjust the tire air pressure properly.
Sways/shimmies	Worn or improperly inflated tire.	In case of worn tire, replace the tire. In case of improperly inflated tire, adjust the tire air pressure properly.

General Diagnostic Table

WHEEL AND TIRE SYSTEM
