

POWER ASSISTED SYSTEM (POWER STEERING)

General Description

POWER ASSISTED SYSTEM (POWER STEERING)

1. General Description

A: SPECIFICATION

Model		NON-TURBO	TURBO	
		2.5i, OUTBACK	WRX	STI
Whole system	Minimum turning radius m (ft)	5.4 (17.7)		5.7 (18.7)
	Steering angle (Inside-Outside)	34.5° — 30.3°		32.9° — 28.5°
	Steering wheel diameter mm (in)	375 (14.76)		375 (14.76)
	Lock-to-lock speed (Turns lock to lock, Gear box)	3.0	2.7	2.6
Gearbox	Type	Rack and pinion, Integral		
	Backlash	0 (Automatically adjustable)		
	Valve (Power steering system)	Rotary valve		
Pump (Power steering system)	Type	Vane pump		
	Oil tank	Installed on body		
	Output cm ³ (cu in)/rev.	7.2 (0.439)	7.2 (0.439)	
	Relief pressure kPa (kgf/cm ² , psi)	6,700 — 7,400 (68 — 75, 972 — 1,073)	7,350 — 8,036 (75 — 82, 1,067 — 1,165)	
	Hydraulic fluid control	Dropping in response to increased engine revolutions		
	Hydraulic fluid ℓ (US qt, Imp qt)	1,000 rpm: 7 (7.4, 6.2) 3,000 rpm: 5 (5.3, 4.4)	7.5 (7.9, 6.6)	
	Range of revolution rpm	700 — 9,000		
	Revolving direction	Clockwise		
Working fluid (Power steering system)	Name	ATF DEXRON III		
	Capacity ℓ (US qt, Imp qt)	Oil tank	0.3 (0.3, 0.3)	
		Total	0.7 (0.7, 0.6)	

General Description

POWER ASSISTED SYSTEM (POWER STEERING)

Steering wheel	Free play	mm (in)	17 (0.67)	
Turning angle	Inner wheel	2.5i, OUTBACK, WRX	34.5°±1.5°	
		STI	32.9°±1.5°	
	Outer wheel	2.5i, OUTBACK, WRX	30.3°±1.5°	
		STI	28.5°±1.5°	
Steering shaft	Clearance between steering wheel and column cover	mm (in)	4.0 (0.16)	
Steering gear-box (Power steering system)	Sliding resistance		N (kgf, lbf)	400 (41, 90) or less
	Rack shaft play in radial direction	Right-turn steering	mm (in)	0.19 (0.0075) or less
		Left-turn steering	mm (in)	Horizontal movement: 0.15 (0.0059) or less Vertical movement: 0.3 (0.012) or less
	Input shaft play	In radial direction	mm (in)	0.18 (0.0071) or less
		In axial direction	mm (in)	0.5 (0.020) or less
	Turning resistance		N (kgf, lbf)	Maximum allowable value: Less than 10.5 (1.1, 2.4) Difference between right and left sliding resistance: Less than 20%
Oil pump (Power steering system)	Pulley shaft	Radial play	mm (in)	0.4 (0.016) or less
		Axial play	mm (in)	0.9 (0.035) or less
	Pulley	Ditch deflection	mm (in)	1.0 (0.039) or less
		Resistance to rotation	N (kgf, lbf)	9.22 (0.94, 2.07) or less
	Regular pressure (Unloaded)		kPa (kgf/cm ² , psi)	981 (10, 142) or less
Steering wheel effort (Power steering system)	At standstill with engine idling on a concrete road		N (kgf, lbf)	31.4 (3.2, 7.1) or less
	At standstill with engine stalled on a concrete road		N (kgf, lbf)	294.2 (30, 66.2) or less

Recommended power steering fluid	Manufacturer
ATF DEXRON III	B.P.
	CALTEX
	CASTROL
	MOBIL
	SHELL
	TEXACO

General Description

POWER ASSISTED SYSTEM (POWER STEERING)

B: COMPONENT

1. STEERING WHEEL AND COLUMN

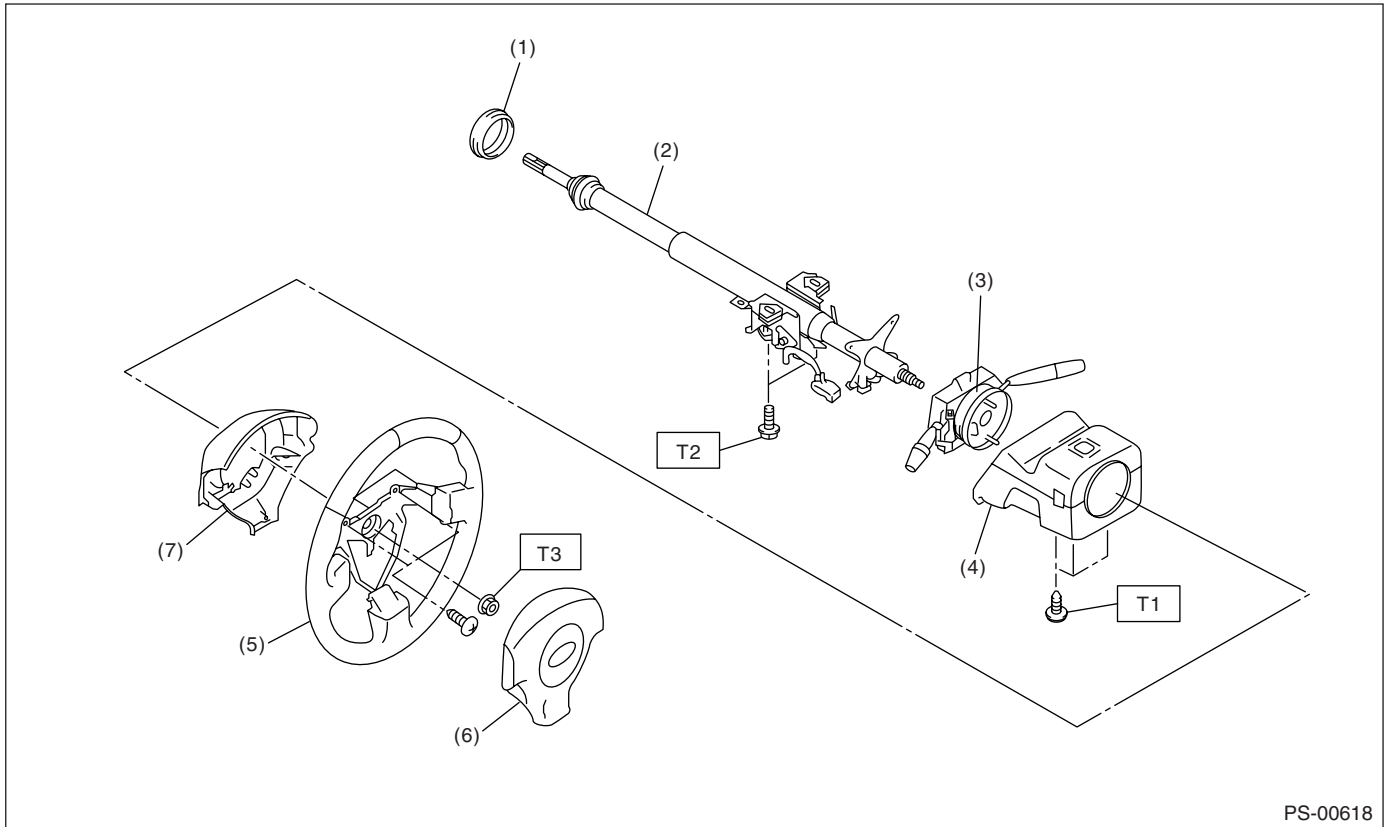

PS-00618

- | | |
|-----------------------------|--------------------------------|
| (1) Bushing | (5) Steering wheel |
| (2) Steering shaft | (6) Airbag module |
| (3) Steering roll connector | (7) Steering wheel lower cover |
| (4) Column cover | |

Tightening torque: N·m (kgf·m, ft·lb)

T1: 1.2 (0.12, 0.9)

T2: 25 (2.5, 18.1)

T3: 45 (4.6, 33.2)

General Description

POWER ASSISTED SYSTEM (POWER STEERING)

2. POWER ASSISTED SYSTEM

• NON-TURBO MODEL

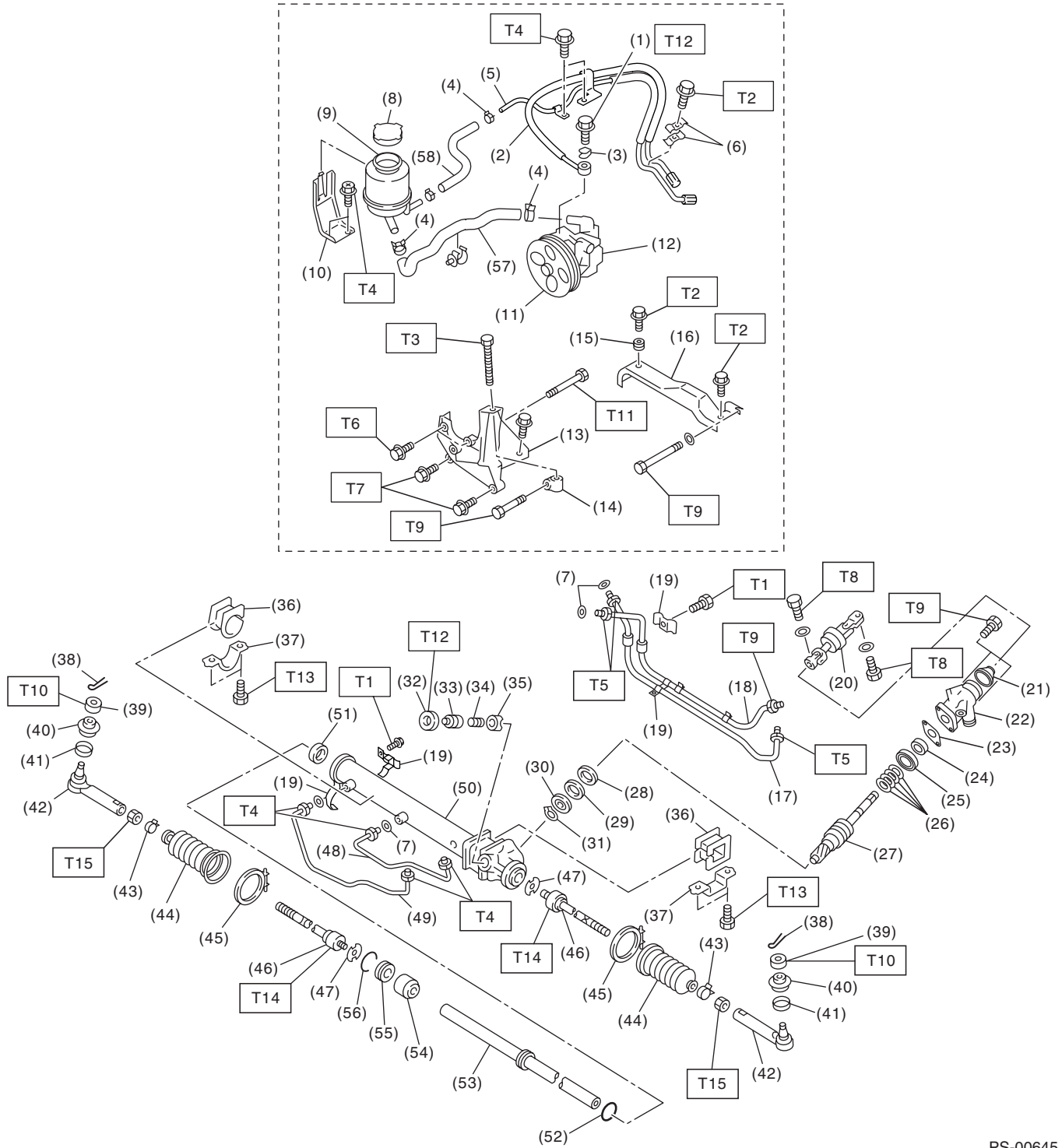

PS-00645

General Description

POWER ASSISTED SYSTEM (POWER STEERING)

(1) Eye bolt	(26) Seal ring	(51) Oil seal
(2) Pipe C	(27) Pinion and valve ASSY	(52) Piston ring
(3) Gasket	(28) Oil seal	(53) Rack
(4) Clip	(29) Back-up washer	(54) Rack bushing
(5) Pipe D	(30) Ball bearing	(55) Rack stopper
(6) Clamp E	(31) Snap ring	(56) Snap ring
(7) O-ring	(32) Lock nut	(57) Suction hose
(8) Cap	(33) Adjusting screw	(58) Hose
(9) Reservoir tank	(34) Spring	
(10) Reservoir tank bracket	(35) Sleeve	<hr/> Tightening torque: N·m (kgf-m, ft-lb)
(11) Pulley	(36) Adapter	T1: 6 (0.6, 4.3)
(12) Oil pump	(37) Clamp	T2: 7.4 (0.75, 5.4)
(13) Bracket	(38) Cotter pin	T3: 8 (0.8, 5.8)
(14) Belt tension nut	(39) Castle nut	T4: 13 (1.3, 9.4)
(15) Bushing	(40) Dust cover	T5: 15 (1.5, 10.8)
(16) Belt cover	(41) Clip	T6: 15.7 (1.6, 11.6)
(17) Pipe E	(42) Tie-rod end	T7: 22 (2.2, 15.9)
(18) Pipe F	(43) Clip	T8: 24 (2.4, 17.4)
(19) Clamp plate	(44) Boot	T9: 25 (2.5, 18.1)
(20) Universal joint	(45) Band	T10: 27 (2.75, 19.9)
(21) Dust seal	(46) Tie-rod	T11: 37.3 (3.8, 27.5)
(22) Valve housing	(47) Lock washer	T12: 40 (4.1, 29.5)
(23) Gasket	(48) Pipe B	T13: 60 (6.1, 44.3)
(24) Oil seal	(49) Pipe A	T14: 78 (8.0, 57.9)
(25) Ball bearing	(50) Steering body	T15: 83 (8.5, 61.5)

General Description

POWER ASSISTED SYSTEM (POWER STEERING)

• TURBO MODEL AND STI MODEL

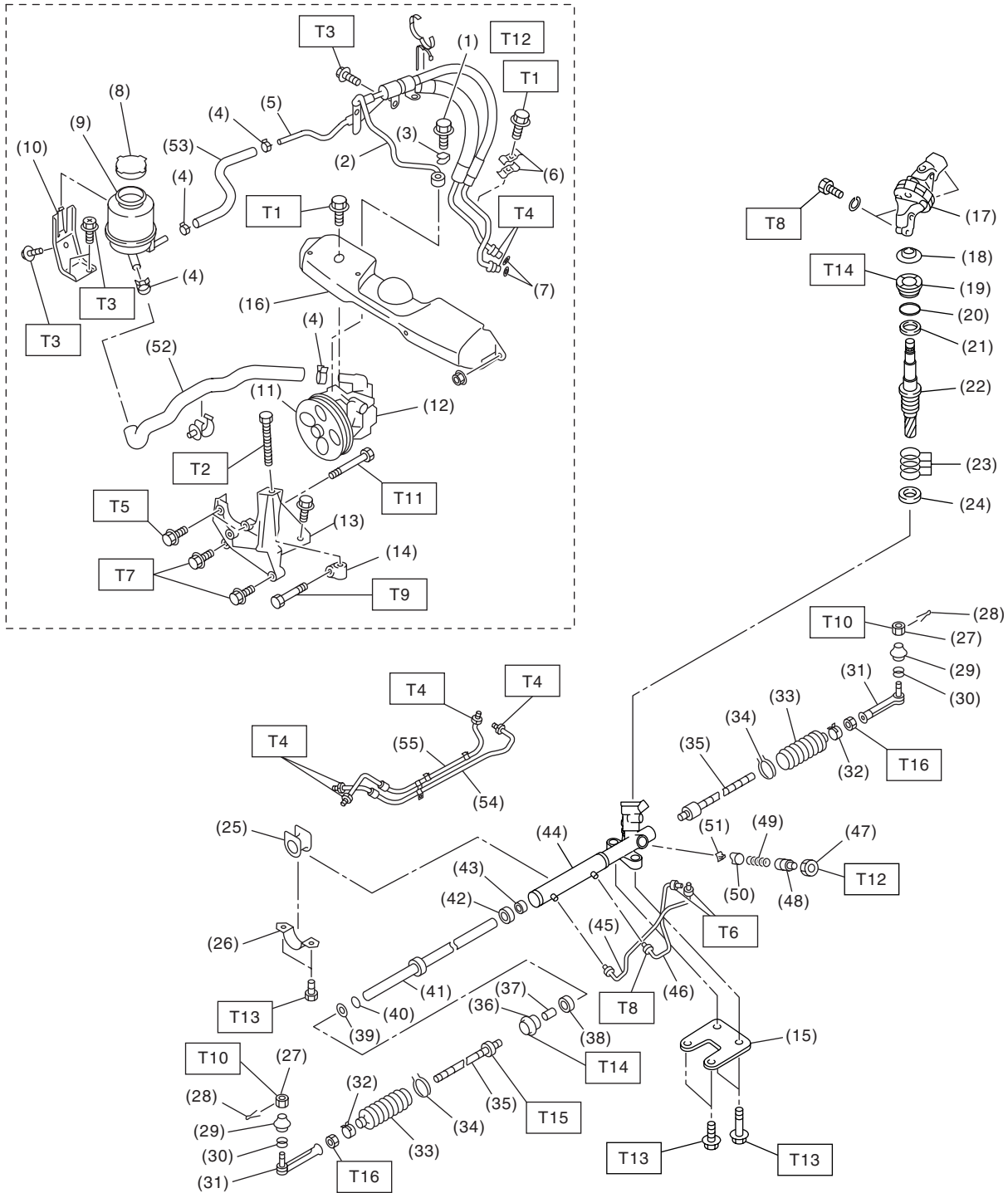

PS-00644

General Description

POWER ASSISTED SYSTEM (POWER STEERING)

(1) Eye bolt	(26) Clamp	(51) Seat pad
(2) Pipe C	(27) Castle nut	(52) Suction hose
(3) Gasket	(28) Cotter pin	(53) Return hose
(4) Clip	(29) Dust seal	(54) Pipe G
(5) Pipe D	(30) Clip	(55) Pipe H
(6) Clamp E	(31) Tie-rod end	
(7) O-ring	(32) Clip	<hr/> Tightening torque: N-m (kgf-m, ft-lb)
(8) Cap	(33) Boot	T1: 7.4 (0.75, 5.4)
(9) Reservoir tank	(34) Wire	T2: 8 (0.8, 5.8)
(10) Reservoir tank bracket	(35) Tie-rod	T3: 13 (1.3, 9.4)
(11) Pulley	(36) Holder	T4: 15 (1.5, 10.8)
(12) Oil pump	(37) Bushing	T5: 15.7 (1.6, 11.6)
(13) Bracket	(38) Oil seal	T6: 20 (2.0, 14.5)
(14) Belt tension nut	(39) Oil seal	T7: 22 (2.2, 15.9)
(15) Stiffener	(40) O-ring	T8: 24 (2.4, 17.4)
(16) Belt cover	(41) Rack	T9: 25 (2.5, 18.1)
(17) Universal joint	(42) Oil seal	T10: 27 (2.75, 19.9)
(18) Dust cover	(43) Back-up washer	T11: 37.3 (3.8, 27.5)
(19) Plug	(44) Steering body	T12: 40 (4.1, 29.5)
(20) O-ring	(45) Pipe A	T13: 60 (6.1, 44.3)
(21) Oil seal	(46) Pipe B	T14: 64 (6.5, 47.0)
(22) Pinion	(47) Lock nut	T15: 90 (9.0, 65.1)
(23) Seal ring	(48) Adjusting screw	T16: 85 (8.6, 62.2)
(24) Oil seal	(49) Spring	<hr/>
(25) Adapter	(50) Sleeve	

General Description

POWER ASSISTED SYSTEM (POWER STEERING)

3. OIL PUMP

• NON-TURBO MODEL

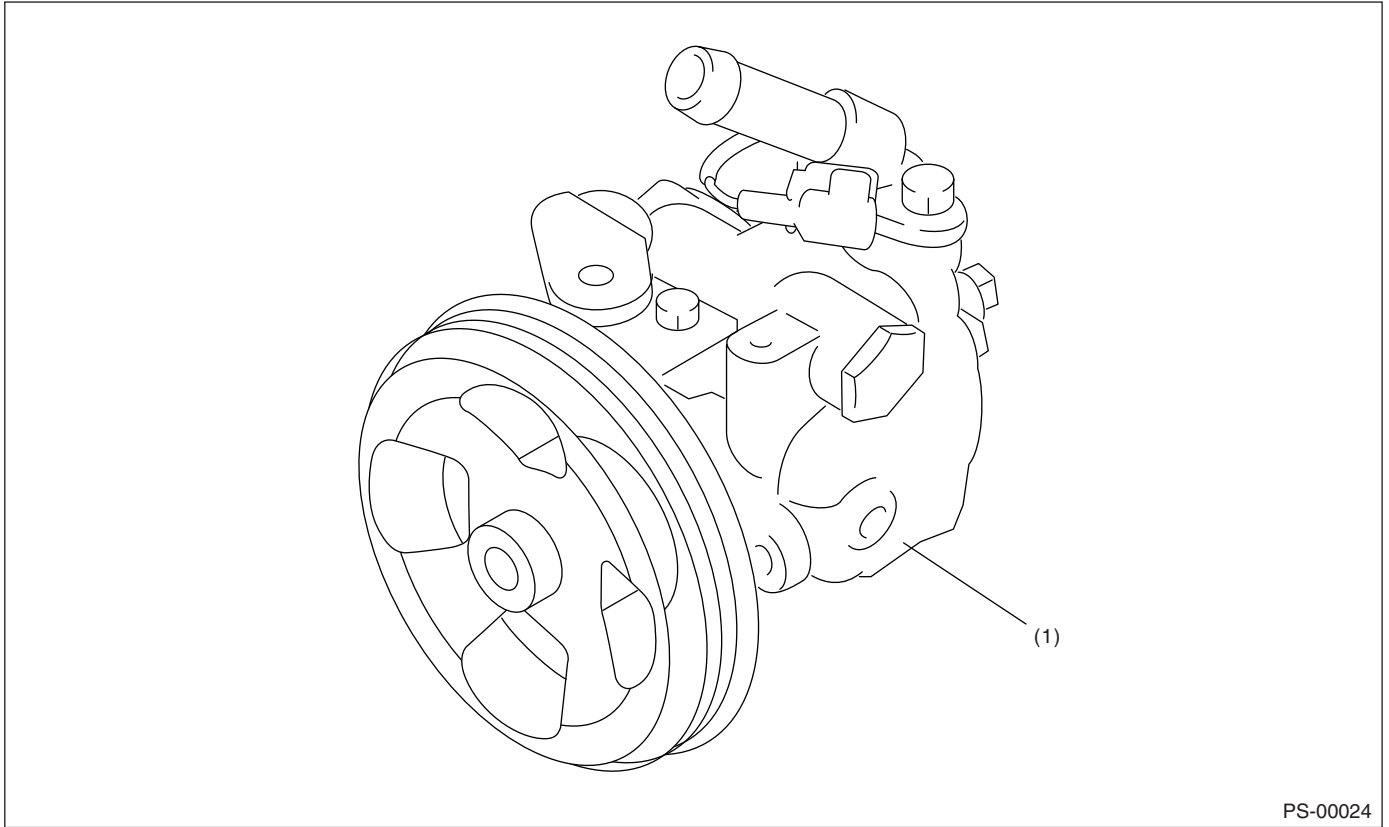

PS-00024

(1) Power steering oil pump ASSY

General Description

POWER ASSISTED SYSTEM (POWER STEERING)

• TURBO MODEL AND STI MODEL

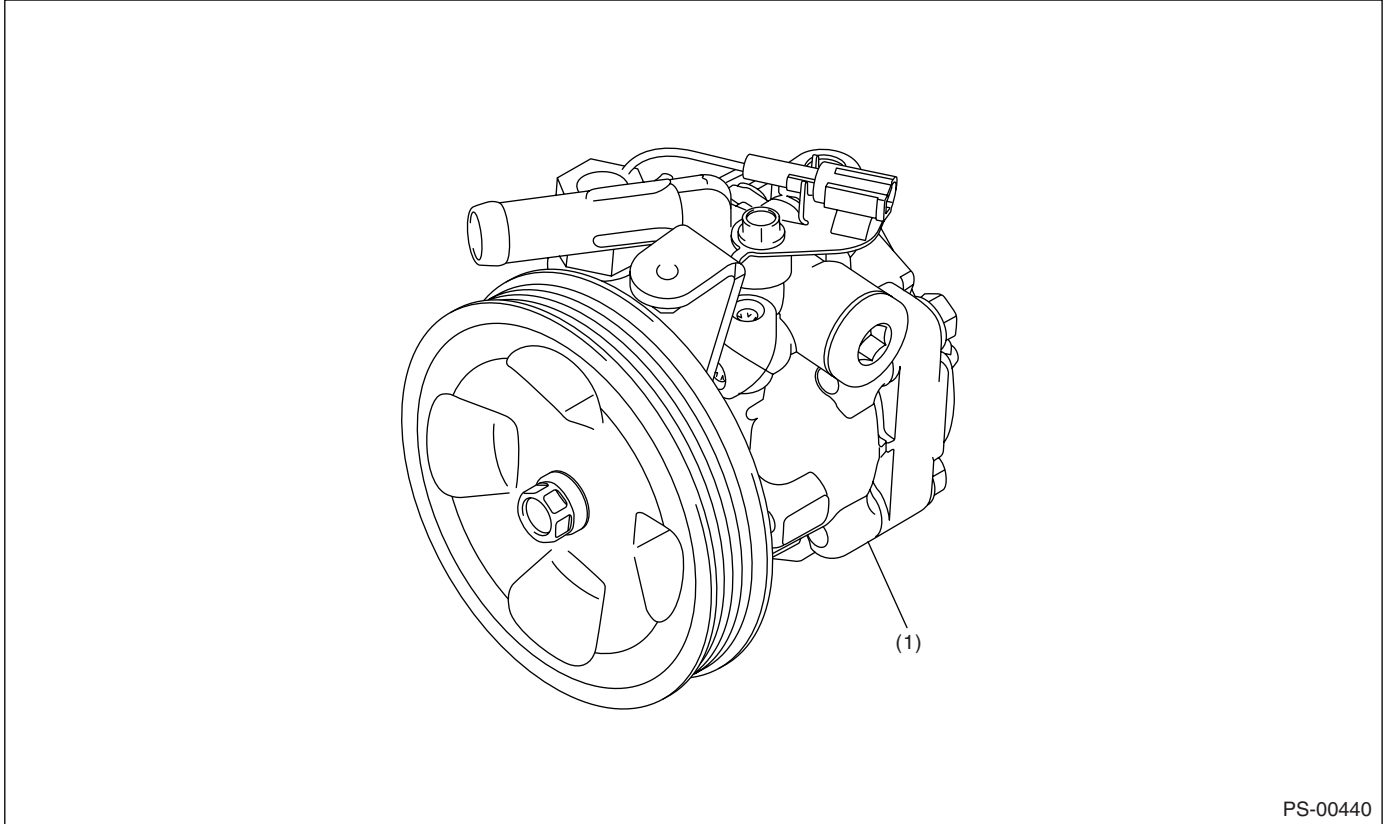

PS-00440

(1) Power steering oil pump ASSY

C: CAUTION

- Wear work clothing, including a cap, protective goggles, and protective shoes during operation.
- Before removal, installation or disassembly, be sure to clarify the failure. Avoid unnecessary removal, installation, disassembly and replacement.
- Be careful not to burn your hands, because each part on the vehicle is hot after running.
- Use genuine power steering fluid, grease etc. or the equivalent. Do not mix steering fluid, grease etc. with that of another grade or from other manufacturers.
- Be sure to tighten fasteners including bolts and nuts to the specified torque.
- Place shop jacks or rigid racks at the specified points.
- Before securing a part on a vise, place cushioning material such as wood blocks, aluminum plate, or shop cloth between the part and the vise.

General Description

POWER ASSISTED SYSTEM (POWER STEERING)

D: PREPARATION TOOL

1. SPECIAL TOOL

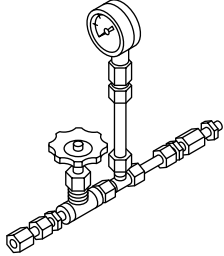
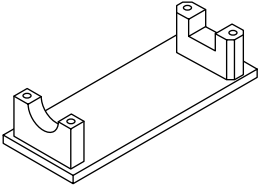
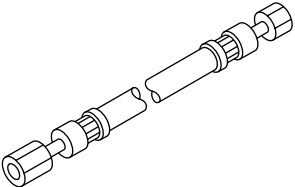
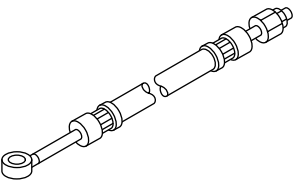
ILLUSTRATION	TOOL NUMBER	DESCRIPTION	REMARKS
 <p style="text-align: center;">ST-925711000</p>	925711000	PRESSURE GAUGE	Used for measuring oil pump pressure.
 <p style="text-align: center;">ST-926200000</p>	926200000	STAND	<ul style="list-style-type: none"> • Used when inspecting characteristic of gear-box assembly and disassembling it. • For Non-turbo model.
 <p style="text-align: center;">ST34099AC010</p>	34099AC010	ADAPTER HOSE A	Used with PRESSURE GAUGE (925711000).
 <p style="text-align: center;">ST34099AC020</p>	34099AC020	ADAPTER HOSE B	Used with PRESSURE GAUGE (925711000).

General Description

POWER ASSISTED SYSTEM (POWER STEERING)

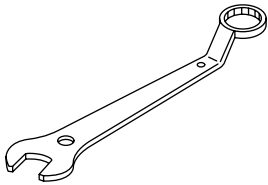
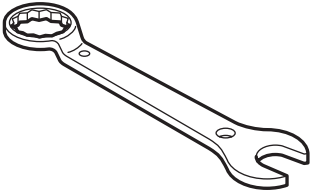
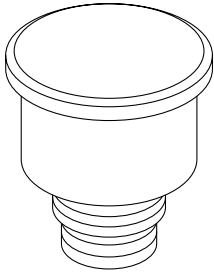
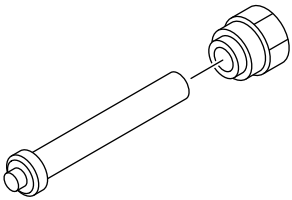
ILLUSTRATION	TOOL NUMBER	DESCRIPTION	REMARKS
 <p style="text-align: center;">ST-926230000</p>	926230000	SPANNER	For the lock nut when adjusting backlash of gear-box.
 <p style="text-align: center;">ST34099PA100</p>	34099PA100	SPANNER	Used for measuring the rotating resistance of gear-box assembly.
 <p style="text-align: center;">ST34199AE040</p>	34199AE040	OIL CHARGE GUIDE	Used for charging power steering fluid.
 <p style="text-align: center;">ST-926420000</p>	926420000	PLUG	When oil leaks from pinion side of gearbox assembly, remove pipe B from valve housing, attach this tool and check oil leaking points.

General Description

POWER ASSISTED SYSTEM (POWER STEERING)

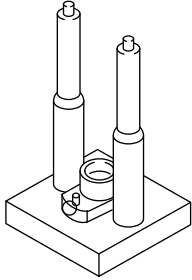
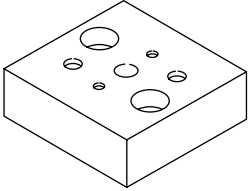
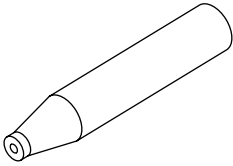
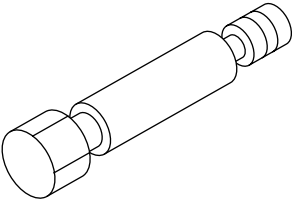
ILLUSTRATION	TOOL NUMBER	DESCRIPTION	REMARKS
 <p data-bbox="337 562 467 583">ST-926370000</p>	926370000	INSTALLER A	<ul style="list-style-type: none"> • Used for installing valve assembly into valve housing assembly. • Used with STAND BASE (34099FA100).
 <p data-bbox="326 978 467 999">ST34099FA100</p>	34099FA100	STAND BASE	Used for assembling power steering gearbox.
 <p data-bbox="337 1398 467 1419">ST-926390001</p>	926390001	COVER & REMOVER ASSY	Used for assembling rack assembly.
 <p data-bbox="337 1818 467 1839">ST-926400000</p>	926400000	GUIDE	<ul style="list-style-type: none"> • Right side of rack when installing rack bushing. • Used with GUIDE (927660000).

General Description

POWER ASSISTED SYSTEM (POWER STEERING)

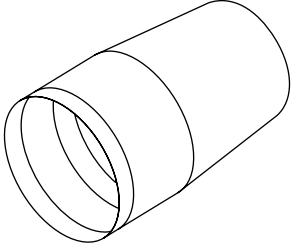
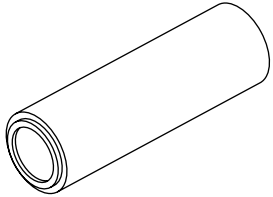
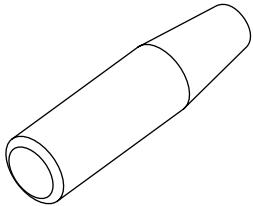
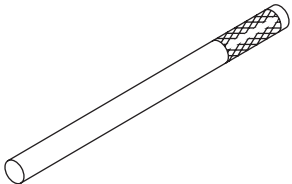
ILLUSTRATION	TOOL NUMBER	DESCRIPTION	REMARKS
 <p style="text-align: center;">ST-927660000</p>	927660000	GUIDE	<ul style="list-style-type: none"> • Right side of rack when installing rack bushing. • Used with GUIDE (926400000).
 <p style="text-align: center;">ST-927620000</p>	927620000	INSTALLER B	<ul style="list-style-type: none"> • Used for installing oil seal of valve housing. • Used with INSTALLER A (926360000).
 <p style="text-align: center;">ST-926360000</p>	926360000	INSTALLER A	<ul style="list-style-type: none"> • Used as a guide to install oil seal. • Used with INSTALLER B (927620000).
 <p style="text-align: center;">ST34199AE050</p>	34199AE050	OIL SEAL REMOVER	Used for removing oil seal.

General Description

POWER ASSISTED SYSTEM (POWER STEERING)

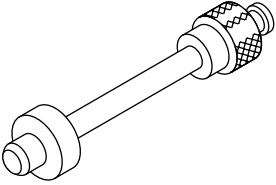
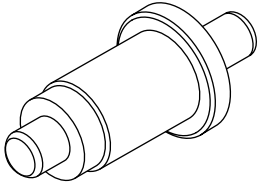
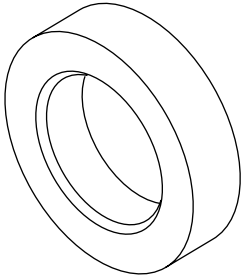
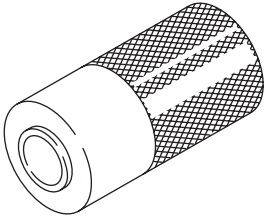
ILLUSTRATION	TOOL NUMBER	DESCRIPTION	REMARKS
 <p style="text-align: center;">ST34099FA110</p>	<p style="text-align: center;">34099FA110</p>	<p style="text-align: center;">INSTALLER</p>	<p>Used for installing oil seal.</p>
 <p style="text-align: center;">ST34099FA120</p>	<p style="text-align: center;">34099FA120</p>	<p style="text-align: center;">INSTALLER AND REMOVER SEAL</p>	<ul style="list-style-type: none"> • Used for installing valve housing oil seal. • Used with INSTALLER SEAL. (34099FA130) • Used for installing valve housing ball bearing. • Used for removing oil seal and ball bearing from valve housing.
 <p style="text-align: center;">ST34099FA130</p>	<p style="text-align: center;">34099FA130</p>	<p style="text-align: center;">INSTALLER SEAL</p>	<ul style="list-style-type: none"> • Used for installing valve housing oil seal. • Used with INSTALLER AND REMOVER SEAL (34099FA120).
 <p style="text-align: center;">ST-927640000</p>	<p style="text-align: center;">927640000</p>	<p style="text-align: center;">INSTALLER B</p>	<p>Used for ball bearing into housing.</p>

General Description

POWER ASSISTED SYSTEM (POWER STEERING)

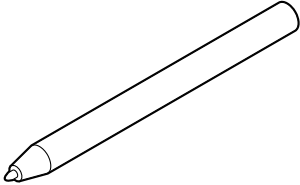
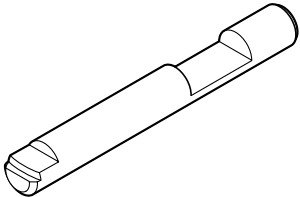
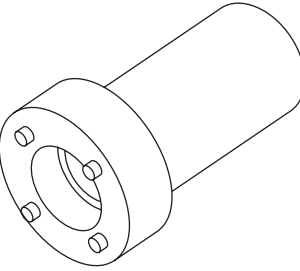
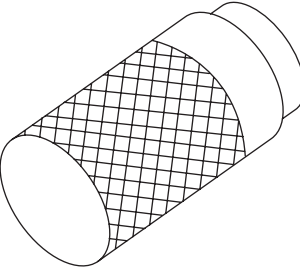
ILLUSTRATION	TOOL NUMBER	DESCRIPTION	REMARKS
 <p style="text-align: center;">ST34099FA060</p>	<p style="text-align: center;">34099FA060</p>	<p>PUNCH HOLDER</p>	<ul style="list-style-type: none"> • Used for caulking. • For Turbo model and STI model.
 <p style="text-align: center;">ST34099FA080</p>	<p style="text-align: center;">34099FA080</p>	<p>PUNCH</p>	<ul style="list-style-type: none"> • Used for removing caulking. • For Turbo model and STI model.
 <p style="text-align: center;">ST34199AE090</p>	<p style="text-align: center;">34199AE090</p>	<p>PLUG WRENCH</p>	<ul style="list-style-type: none"> • Used for removing plug. • For Turbo model and STI model.
 <p style="text-align: center;">ST34199AE100</p>	<p style="text-align: center;">34199AE100</p>	<p>PLUG OIL SEAL REMOVER</p>	<ul style="list-style-type: none"> • Used for removing plug oil seal. • For Turbo model and STI model.

General Description

POWER ASSISTED SYSTEM (POWER STEERING)

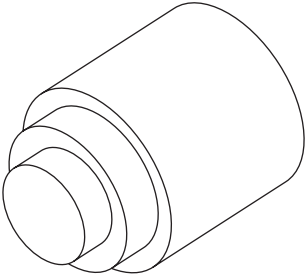
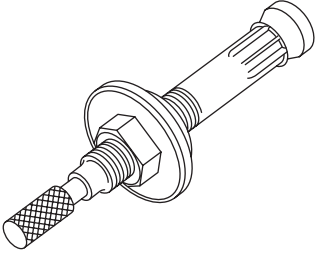
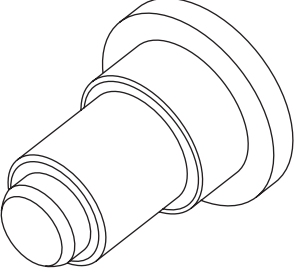
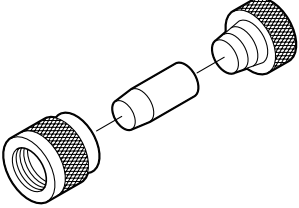
ILLUSTRATION	TOOL NUMBER	DESCRIPTION	REMARKS
 <p data-bbox="326 548 467 569">ST34199AE110</p>	34199AE110	PLUG OIL SEAL INSTALLER	<ul data-bbox="976 201 1341 254" style="list-style-type: none"> • Used for installing plug oil seal. • For Turbo model and STI model.
 <p data-bbox="326 947 467 968">ST34199AE120</p>	34199AE120	GEARBOX OIL SEAL REMOVER	<ul data-bbox="976 604 1373 657" style="list-style-type: none"> • Used for removing gearbox oil seal. • For Turbo model and STI model.
 <p data-bbox="326 1350 467 1371">ST34199AE130</p>	34199AE130	GEARBOX OIL SEAL INSTALLER	<ul data-bbox="976 1008 1369 1060" style="list-style-type: none"> • Used for installing gearbox oil seal. • For Turbo model and STI model.
 <p data-bbox="326 1755 467 1776">ST34199FE040</p>	34199FE040	INSTALLER A, B, C	<ul data-bbox="976 1411 1479 1463" style="list-style-type: none"> • Used for installing oil seal into rack assembly. • For Turbo model and STI model.

General Description

POWER ASSISTED SYSTEM (POWER STEERING)

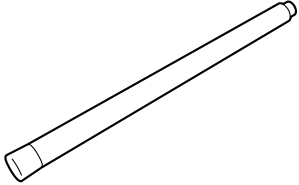
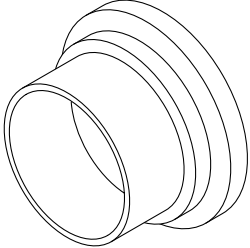
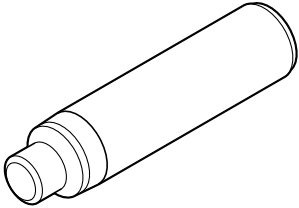
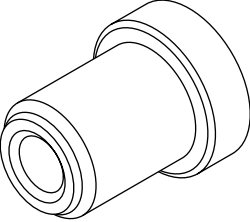
ILLUSTRATION	TOOL NUMBER	DESCRIPTION	REMARKS
 <p style="text-align: center;">ST34199FE010</p>	<p style="text-align: center;">34199FE010</p>	<p>REMOVER</p>	<ul style="list-style-type: none"> • Used for removing back-up ring and oil seal. • For Turbo model and STI model.
 <p style="text-align: center;">ST34199FE050</p>	<p style="text-align: center;">34199FE050</p>	<p>GUIDE</p>	<ul style="list-style-type: none"> • Used for installing rack and seal into housing assembly. • For Turbo model and STI model.
 <p style="text-align: center;">ST34199FE000</p>	<p style="text-align: center;">34199FE000</p>	<p>INSTALLER & REMOVER</p>	<ul style="list-style-type: none"> • Used for removing and installing rack oil seal (outer & inner). • For Turbo model and STI model.
 <p style="text-align: center;">ST34199FE060</p>	<p style="text-align: center;">34199FE060</p>	<p>INSTALLER</p>	<ul style="list-style-type: none"> • Used for installing rack oil seal (outer). • For Turbo model and STI model.

General Description

POWER ASSISTED SYSTEM (POWER STEERING)

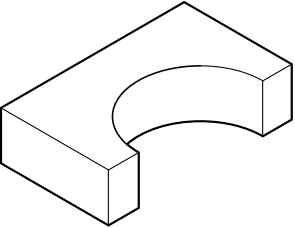
ILLUSTRATION	TOOL NUMBER	DESCRIPTION	REMARKS
 ST34199FE020	34199FE020	BASE	<ul style="list-style-type: none">• Used for supporting housing assembly.• For Turbo model and STI model.

2. GENERAL TOOL

TOOL NAME	REMARKS
Spring scale	Used for measuring tightening torque.
Snap ring pliers	Used for removing and installing snap ring.
Dial gauge	Used for measuring steering gearbox.
C-clamp	Used for disassembling and assembling steering gearbox of Turbo model and STI model.

Steering Wheel

POWER ASSISTED SYSTEM (POWER STEERING)

2. Steering Wheel

A: REMOVAL

- 1) Disconnect the ground cable from battery.
- 2) Set the tires to straight-ahead position.
- 3) Remove the airbag module. <Ref. to AB-14, REMOVAL, Driver's Airbag Module.>

WARNING:

Always refer to "Airbag System" before performing airbag module service. <Ref. to AB-3, CAUTION, General Description.>

- 4) Make matching marks on the steering wheel and steering shaft.

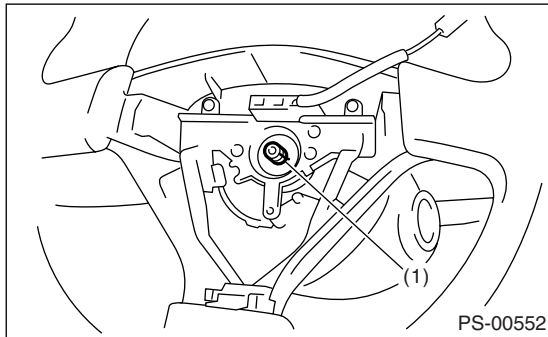

(1) Matching mark

- 5) Remove the steering wheel nut, and then draw out the steering wheel from shaft using steering puller.

B: INSTALLATION

WARNING:

Always refer to "Airbag System" before performing airbag module service. <Ref. to AB-3, CAUTION, General Description.>

- 1) Align the center of roll connector. <Ref. to AB-20, ADJUSTMENT, Roll Connector.>
- 2) Install in the reverse order of removal.

NOTE:

Align matching marks on the steering wheel and steering shaft.

Tightening torque:

45 N·m (4.6 kgf-m, 33.2 ft-lb)

Column cover-to-steering wheel clearance:

2 — 4 mm (0.08 — 0.16 in)

CAUTION:

Insert the roll connector guide pin into guide hole on lower end of surface of steering wheel to prevent damage.

C: INSPECTION

- 1) Check the steering wheel for deformation. If the deformation is excessive, replace steering wheel.
- 2) Check the splines on steering wheel for damage. If the damage is excessive, replace steering wheel.

Universal Joint

POWER ASSISTED SYSTEM (POWER STEERING)

3. Universal Joint

A: REMOVAL

- 1) Remove the steering wheel. <Ref. to PS-20, REMOVAL, Steering Wheel.>
- 2) Make matching mark on the universal joint.
- 3) Remove the universal joint bolts, and then remove the universal joint.

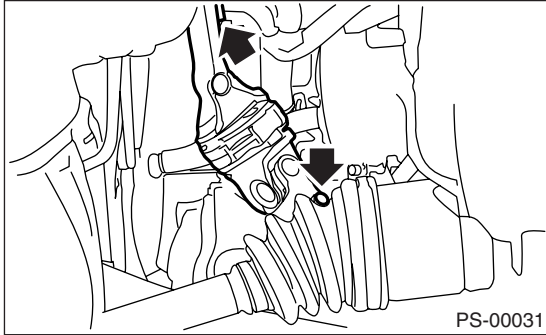

B: INSTALLATION

- 1) Align the cutout at serrated section of the column shaft and yoke, and then insert the universal joint into column shaft.

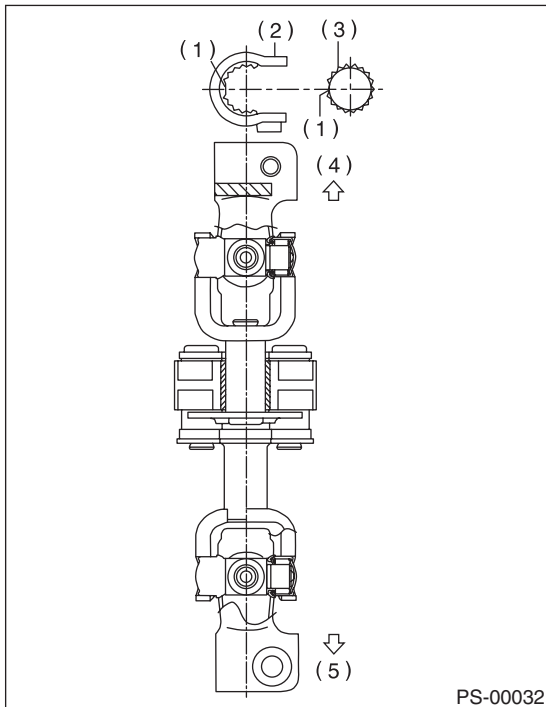

- (1) Cutout
- (2) Yoke
- (3) Column shaft
- (4) Column shaft side
- (5) Gearbox side

- 2) Align the matching marks, and then insert the universal joint to serrated section of gear box assembly.
- 3) Tighten the bolt.

Tightening torque:

24 N·m (2.4 kgf-m, 17.4 ft-lb)

CAUTION:

Excessively large tightening torque of the universal joint bolts may lead to heavy steering wheel operation.

Standard clearance between gearbox to DOJ:

Over 14 mm (0.55 in)

- 4) Align the center of roll connector. <Ref. to AB-20, ADJUSTMENT, Roll Connector.>

- 5) Install the steering wheel and airbag module. <Ref. to PS-20, INSTALLATION, Steering Wheel.>

WARNING:

Always refer to "Airbag System" before performing airbag module service. <Ref. to AB-3, CAUTION, General Description.>

C: INSPECTION

Check for wear, damage, or any other faults. If necessary, replace.

Service limit:

Universal joint play:

0 mm (0 in)

Maximum swing torque:

0.3 N (0.03 kgf, 0.07 lbf)

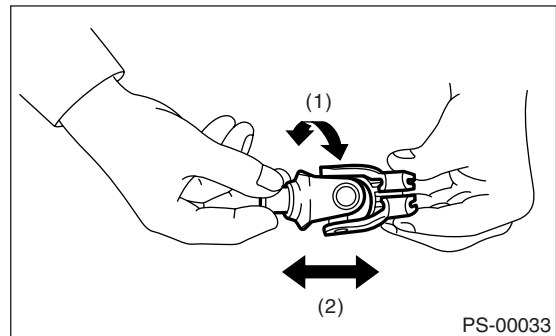

- (1) Swing torque
- (2) Play

Measurement of swing torque of universal joint is as shown in the figures.

Universal Joint

POWER ASSISTED SYSTEM (POWER STEERING)

Service limit:

Maximum load: 3.8 N (0.39 kgf, 0.86 lbf) or less

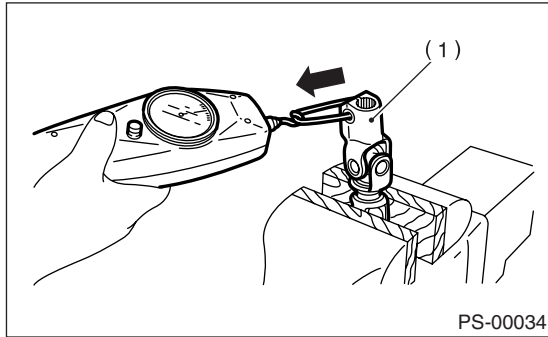

(1) Yoke (gearbox side)

Service limit:

Maximum load: 7.3 N (0.74 kgf, 1.64 lbf) or less

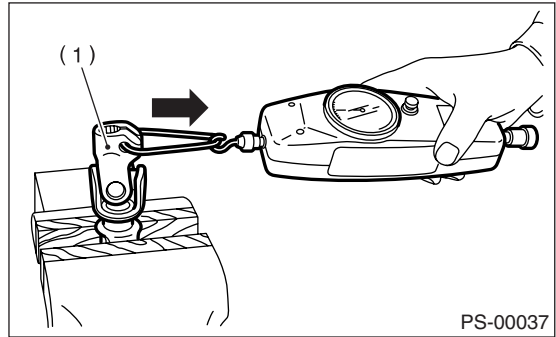

(1) Yoke (Steering column side)

Service limit:

Maximum load: 3.8 N (0.39 kgf, 0.86 lbf) or less

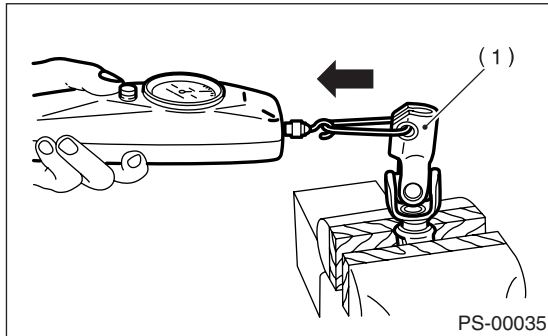

(1) Yoke (gearbox side)

Service limit:

Maximum load: 7.3 N (0.74 kgf, 1.64 lbf) or less

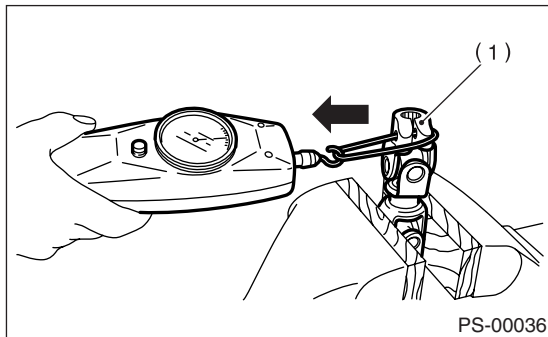

(1) Yoke (Steering column side)

Tilt Steering Column

POWER ASSISTED SYSTEM (POWER STEERING)

4. Tilt Steering Column

A: REMOVAL

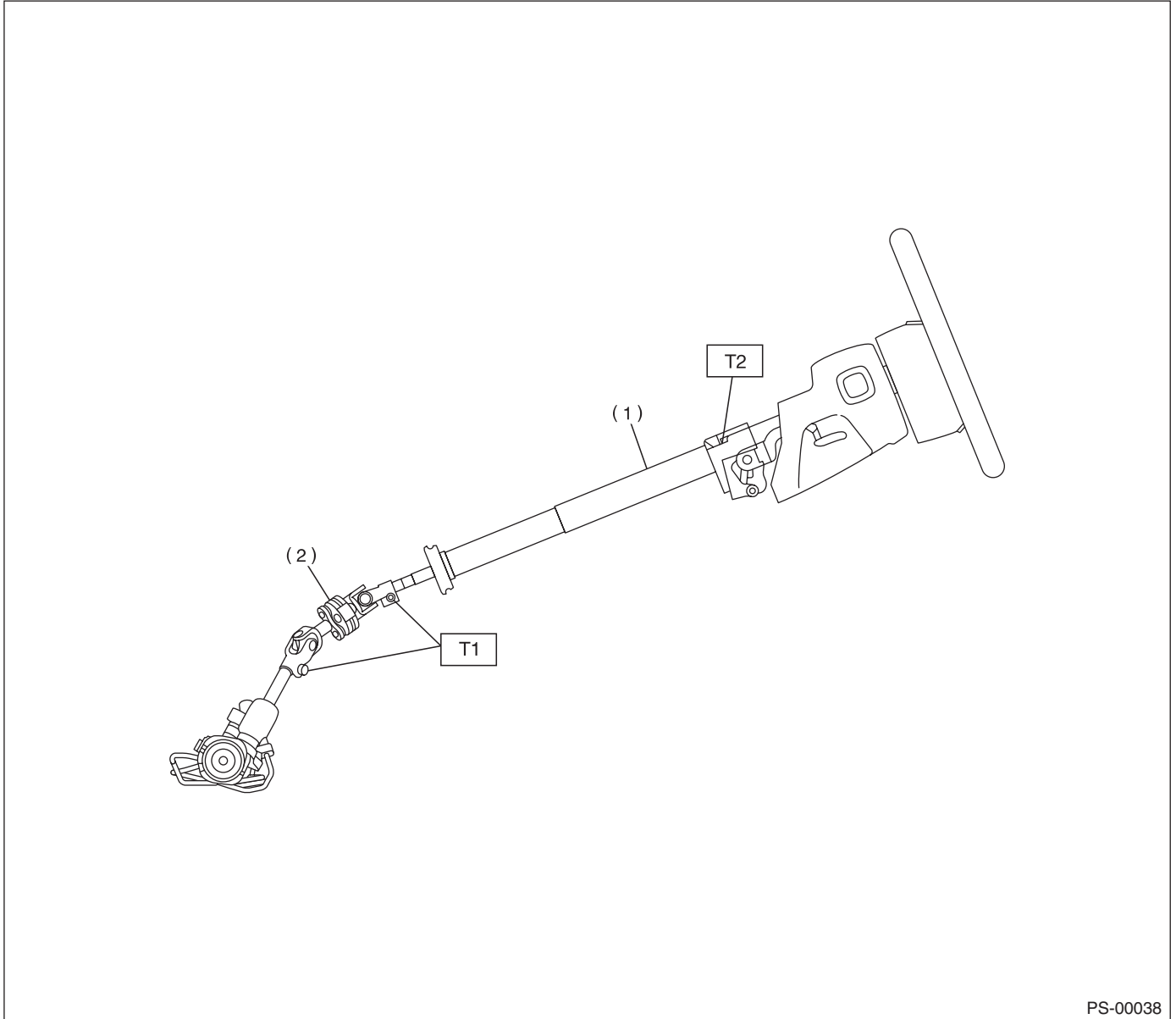

PS-00038

(1) Tilt steering column

(2) Universal joint

Tightening torque: N·m (kgf·m, ft·lb)

T1: 24 (2.4, 17.4)

T2: 25 (2.5, 18.1)

Tilt Steering Column

POWER ASSISTED SYSTEM (POWER STEERING)

- 1) Set the vehicle on a lift.
- 2) Disconnect the ground cable from battery.
- 3) Remove the airbag module. <Ref. to AB-14, REMOVAL, Driver's Airbag Module.>

WARNING:

Always refer to "Airbag System" before performing airbag module service. <Ref. to AB-3, CAUTION, General Description.>

- 4) Remove the steering wheel. <Ref. to PS-20, REMOVAL, Steering Wheel.>
- 5) Remove the universal joint. <Ref. to PS-21, REMOVAL, Universal Joint.>
- 6) Remove the trim panel under instrument panel.
- 7) Remove the steering column lower cover.
- 8) Remove all connectors from steering column.
- 9) Remove the two bolts under instrument panel securing steering column.

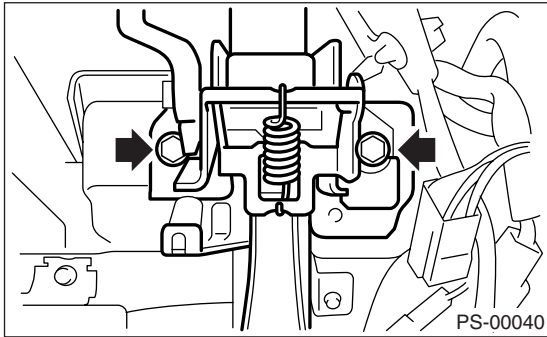

- 10) Pull out the steering shaft assembly from hole on toe board.

CAUTION:

- Be sure to remove the universal joint before removing the steering shaft assembly installing bolts when removing the steering shaft assembly or when lowering it for servicing of other parts.
- Do not loosen the tilt lever when the steering column is not secured to the vehicle.

B: INSTALLATION

- 1) Set the grommet to toe board.

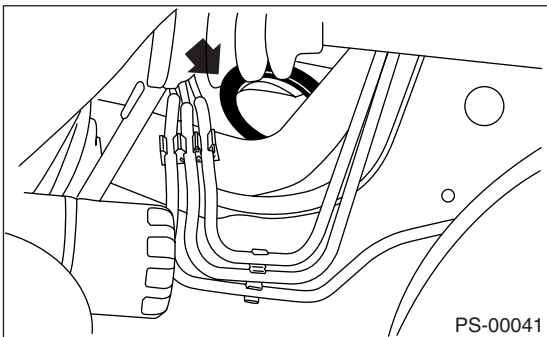

- 2) Insert the end of steering shaft into toe board grommet.

- 3) With the tilt lever secured, tighten the steering shaft mounting bolts under instrument panel.

Tightening torque:

25 N·m (2.5 kgf-m, 18.1 ft-lb)

- 4) Connect all connectors under instrument panel.
- 5) Connect the airbag system connector at harness spool.

NOTE:

Make sure to apply double lock.

- 6) Install the lower column cover with tilt lever held in the lowered position.
- 7) Install the universal joint. <Ref. to PS-21, INSTALLATION, Universal Joint.>
- 8) Align center of roll connector. <Ref. to AB-20, ADJUSTMENT, Roll Connector.>
- 9) Install the steering wheel. <Ref. to PS-20, INSTALLATION, Steering Wheel.>

CAUTION:

Insert the roll connector guide pin into guide hole on lower end of surface of steering wheel to prevent damage.

- 10) Install the airbag module to steering wheel.

WARNING:

Always refer to "Airbag System" before performing the service operation. <Ref. to AB-3, CAUTION, General Description.>

C: DISASSEMBLY

Remove the two screws securing upper steering column covers, and two screws securing combination switch, and then remove the related parts.

D: ASSEMBLY

- 1) Insert the combination switch to upper column shaft, and then install the upper column cover. Then route the ignition key harness and combination switch harness between column cover mounting bosses.

Tightening torque:

1.2 N·m (0.12 kgf-m, 0.9 ft-lb)

CAUTION:

Do not overtighten the screw.

Tilt Steering Column

POWER ASSISTED SYSTEM (POWER STEERING)

E: INSPECTION

1. BASIC INSPECTION

Measure overall length of the steering column. If not as specified, replace.

Standard value:

Overall length L

818.7 ± 1.5 mm (32.23 ± 0.059 in)

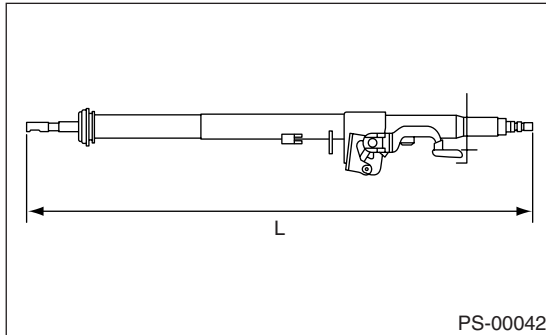

2. AIRBAG MODEL INSPECTION

WARNING:

For airbag inspection procedures, refer to “Airbag System”. <Ref. to AB-3, CAUTION, General Description.>

Steering Gearbox

POWER ASSISTED SYSTEM (POWER STEERING)

5. Steering Gearbox

A: REMOVAL

- 1) Set the vehicle on a lift.
- 2) Disconnect the ground cable from battery.
- 3) Loosen the front wheel nut.
- 4) Lift-up the vehicle, and then remove the front wheels.
- 5) Remove the under cover. <Ref. to EI-23, REMOVAL, Front Under Cover.>
- 6) Remove the sub frame. <Ref. to FS-24, REMOVAL, Sub Frame.>
- 7) Remove the front exhaust pipe assembly. (Non-turbo model)
<Ref. to EX(H4SO)-4, REMOVAL, Front Exhaust Pipe.>

WARNING:

Be careful, the exhaust pipe is hot.

- 8) Using a puller, remove the tie-rod end from knuckle arm after pulling off cotter pin and removing castle nut.

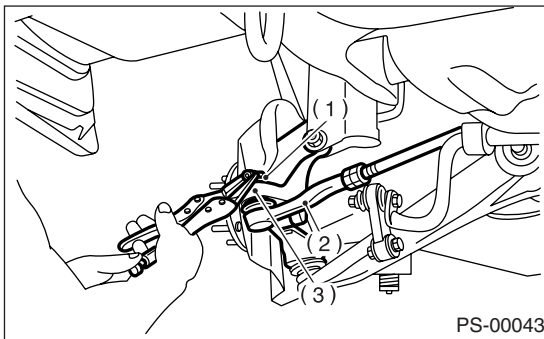

- (1) Castle nut
- (2) Tie-rod end
- (3) Knuckle arm

- 9) Remove the jack-up plate and front stabilizer.

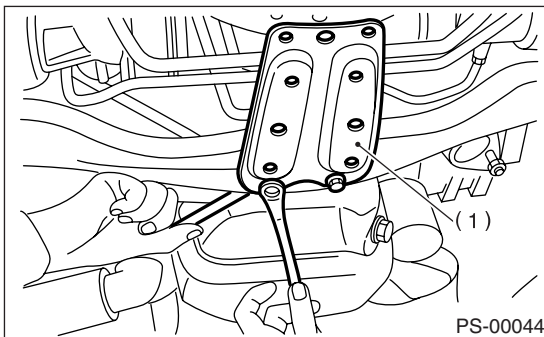

- (1) Jack-up plate

- 10) Remove the one pipe joint at center of gearbox, and connect vinyl hose to pipe and joint. Discharge fluid by turning the steering wheel fully clockwise and counterclockwise. Discharge fluid similarly from the other pipe.

- Non-turbo model

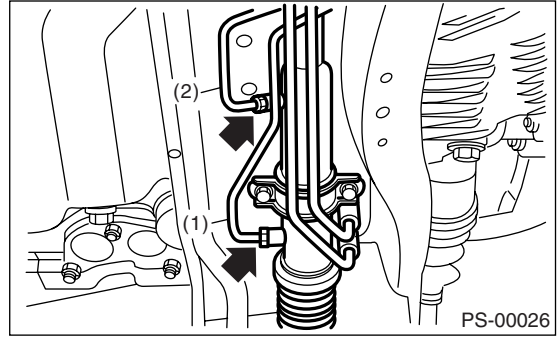

- (1) Pipe A
- (2) Pipe B

- Turbo model

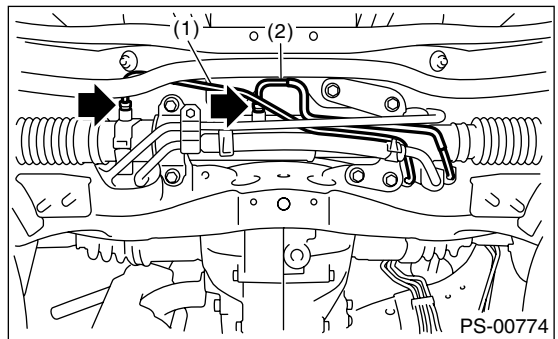

- (1) Pipe A
- (2) Pipe B

- 11) Remove the universal joint. <Ref. to PS-21, REMOVAL, Universal Joint.>

- 12) Disconnect the lower pipe C from gear box first, and upper pipe D second.

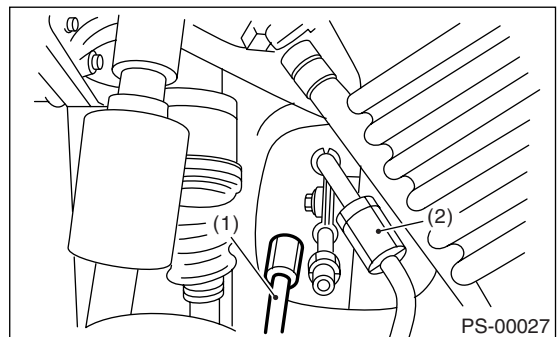

- (1) Pipe C
- (2) Pipe D

- 13) Remove the clamp bolts securing the gearbox to crossmember, and then remove the gearbox.

Steering Gearbox

POWER ASSISTED SYSTEM (POWER STEERING)

- Non-turbo model

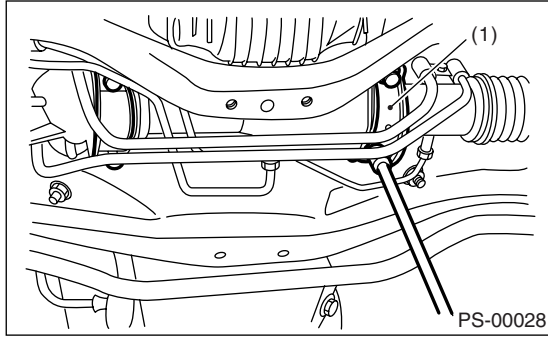

(1) Clamp

- Turbo model

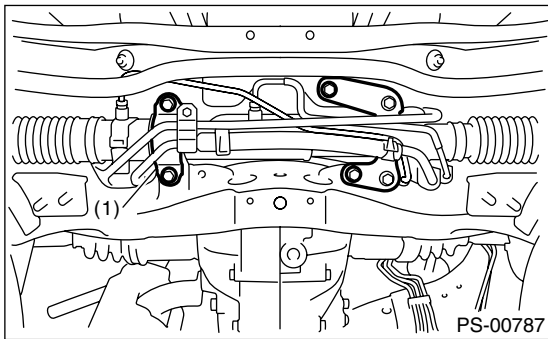

(1) Clamp

B: INSTALLATION

- 1) Insert the gearbox into crossmember, being careful not to damage the gearbox boot.
- 2) Tighten the gearbox to crossmember bracket via clamp with bolts to specified torque.

Tightening torque:

60 N·m (6.1 kgf·m, 44.3 ft·lb)

- Non-turbo model

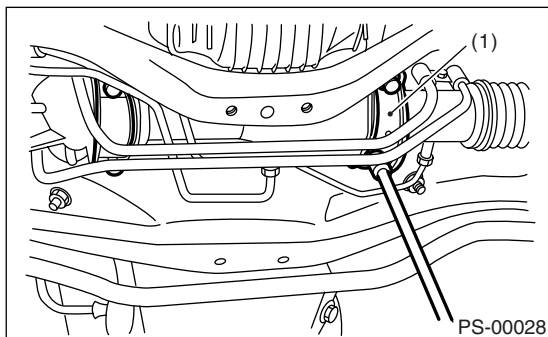

(1) Clamp

- Turbo model

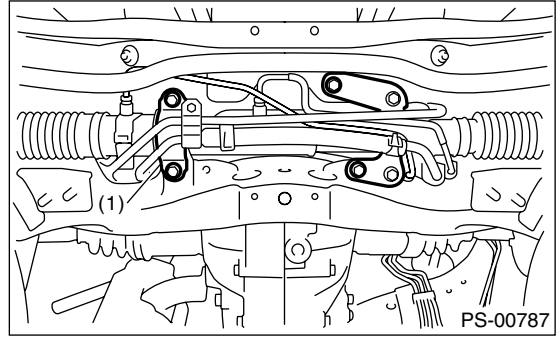

(1) Clamp

- 3) Connect the pipe D first to gear box, and pipe C second.

Tightening torque:

15 N·m (1.5 kgf·m, 10.8 ft·lb)

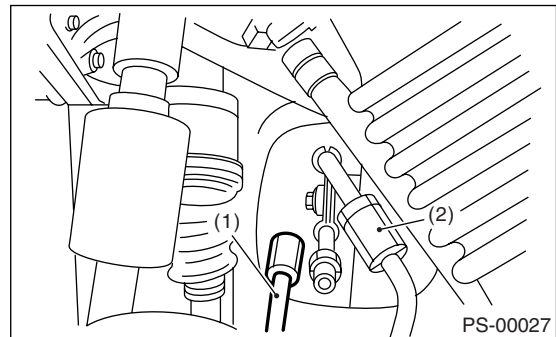

(1) Pipe C

(2) Pipe D

- 4) Install the universal joint. <Ref. to PS-21, INSTALLATION, Universal Joint.>
- 5) Connect the tie-rod end and knuckle arm, and tighten with castle nut.

Tightening torque (Castle nut):

27 N·m (2.75 kgf·m, 19.9 ft·lb)

CAUTION:

When connecting, do not hit the cap at bottom of tie-rod end with hammer.

Steering Gearbox

POWER ASSISTED SYSTEM (POWER STEERING)

6) After tightening the castle nut to specified torque, tighten it further within 60° until cotter pin hole is aligned with the slot in nut, and then bend the cotter pin to lock.

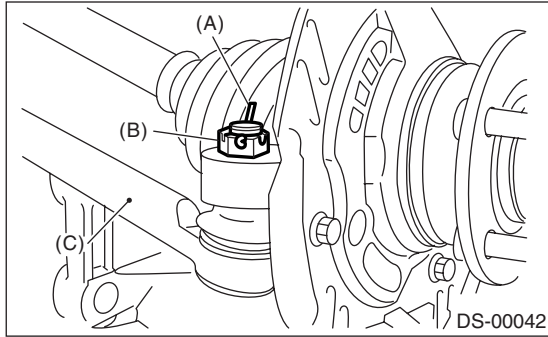

- (A) Cotter pin
- (B) Castle nut
- (C) Tie-rod end

7) Install the front stabilizer to vehicle. <Ref. to FS-22, INSTALLATION, Front Stabilizer.>

8) Install the front exhaust pipe assembly. (Non-turbo model) <Ref. to EX(H4SO)-4, INSTALLATION, Front Exhaust Pipe.>

9) Install the sub frame. <Ref. to FS-24, INSTALLATION, Sub Frame.>

10) Install the under cover. <Ref. to EI-23, INSTALLATION, Front Under Cover.>

11) Align the center of roll connector. <Ref. to AB-20, ADJUSTMENT, Roll Connector.>

12) Install the steering wheel. <Ref. to PS-20, INSTALLATION, Steering Wheel.>

13) Install the front wheels.

14) Tighten the wheel nuts to specified torque.

Tightening torque:

90 N-m (9.0 kgf-m, 65.1 ft-lb)

15) Connect the battery ground cable to battery.

16) Pour fluid into the oil tank, and bleed air.

<Ref. to PS-68, Power Steering Fluid.>

17) Check for fluid leaks.

18) Install the jack-up plate.

19) Lower the vehicle.

20) Check the fluid level in oil tank.

21) After adjusting the toe-in and steering angle, tighten the lock nut on tie-rod end.

Tightening torque:

83 N-m (8.5 kgf-m, 61.5 ft-lb)

NOTE:

When adjusting the toe-in, hold boot as shown to prevent it from being rotated or twisted. If twisted, straighten it.

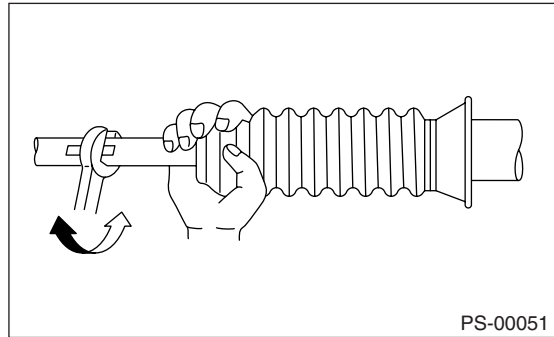

C: DISASSEMBLY

1. NON-TURBO MODEL

• RACK HOUSING ASSEMBLY

1) Disconnect the four pipes from gearbox.

NOTE:

Remove the pipes E and F as a single unit being fixed at clamp plate.

2) Secure the gearbox removed from vehicle in vice using ST.

ST 926200000 STAND

CAUTION:

Secure the gearbox in a vise using ST as shown. Do not attempt to secure it without this ST.

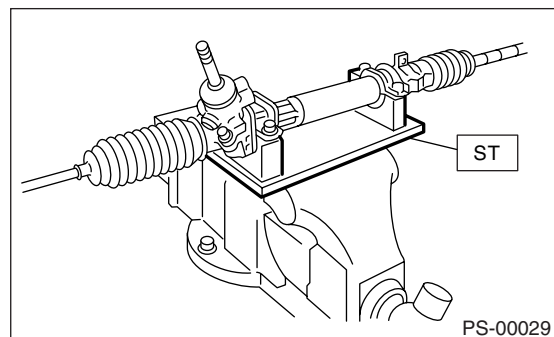

3) Remove the tie-rod end and lock nut from gearbox.

Steering Gearbox

POWER ASSISTED SYSTEM (POWER STEERING)

4) Remove the small clip from boot using pliers, and then move the boot to tie-rod end side.

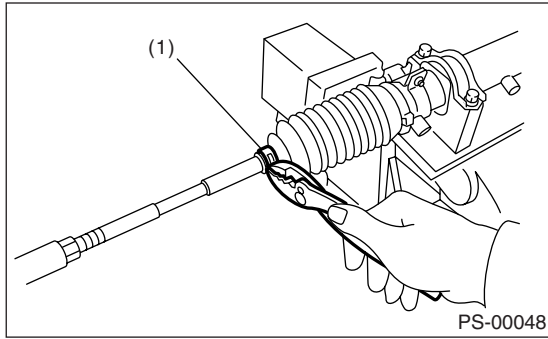

(1) Clip

5) Using a flat tip screwdriver, remove the band from boot.

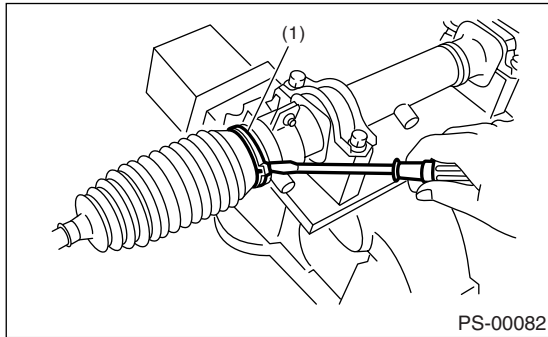

(1) Band

6) Extend the rack approx. 40 mm (1.57 in) out. Unlock the lock washer on both side of tie-rod end using a flat tip screwdriver.

CAUTION:

Be careful not to scratch the rack surface as oil leaks may result.

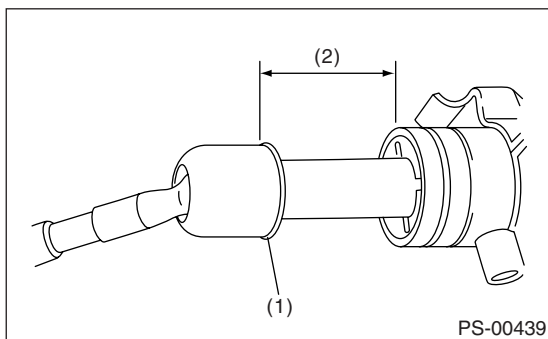

(1) Lock washer

(2) Approx. 40 mm (1.57 in)

7) Using the ST, loosen the lock nut.

ST 926230000 SPANNER

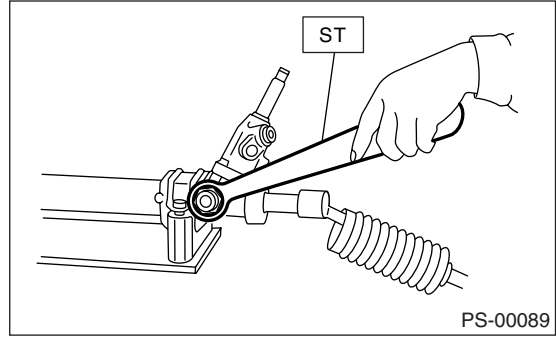

8) Tighten the adjusting screw until it no longer tightens.

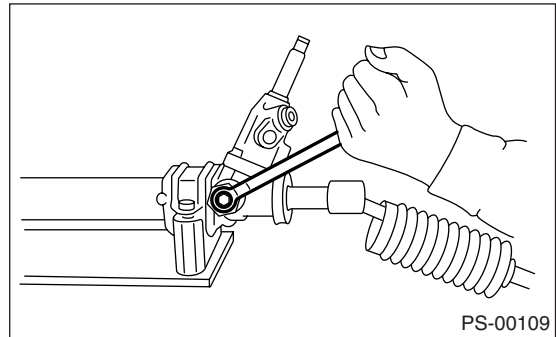

9) Using a wrench [32 mm width across flats] or adjustable wrench, remove the tie-rod.

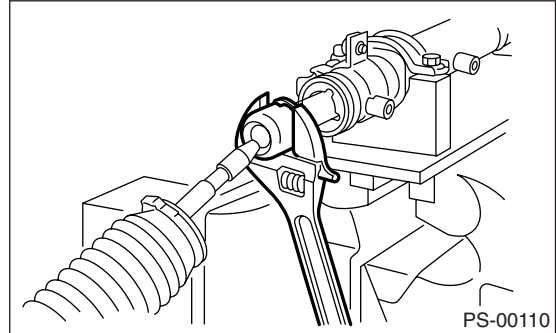

10) Loosen the adjusting screw, and then remove the spring and sleeve.

11) Remove the two bolts securing valve assembly.

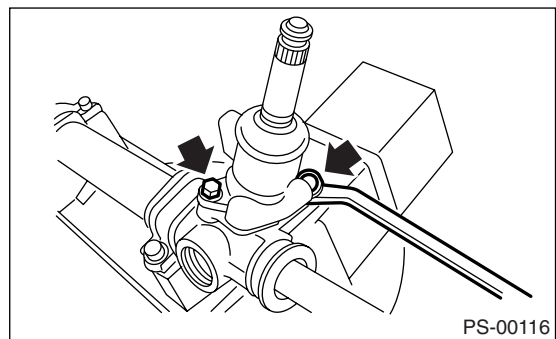

Steering Gearbox

POWER ASSISTED SYSTEM (POWER STEERING)

12) Carefully draw out the input shaft, and then remove the valve assembly.

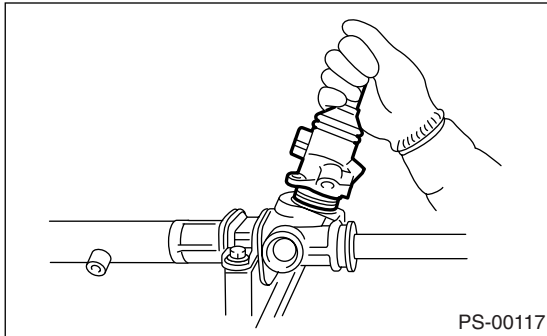

13) Using a sharp pointed pliers, rotate the rack stopper in direction of the arrow until end of the circlip comes out of stopper. Rotate the circlip in opposite direction and pull it out.

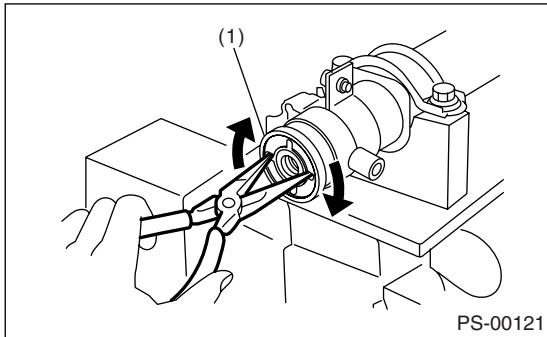

(1) Rack stopper

14) Pull the rack assembly from cylinder side, and draw out the rack bushing and rack stopper together with the rack assembly.

CAUTION:

Be careful not to contact the rack to inner wall of cylinder when drawing out. Any scratch on the cylinder inner wall will cause oil leakage.

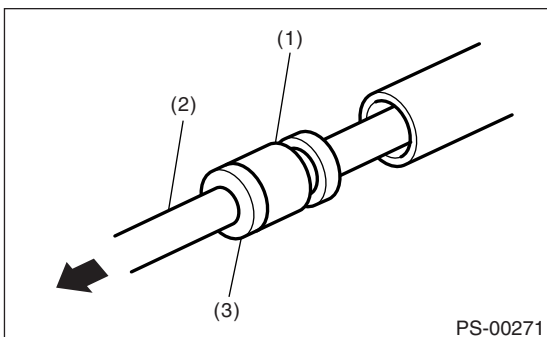

(1) Rack bushing
(2) Rack ASSY
(3) Rack stopper

15) Remove the rack bushing and rack stopper from rack assembly.

16) Remove the oil seal from rack.

17) Insert the ST from pinion housing side, and then remove the oil seal using a press.

ST 34199AE050 OIL SEAL REMOVER

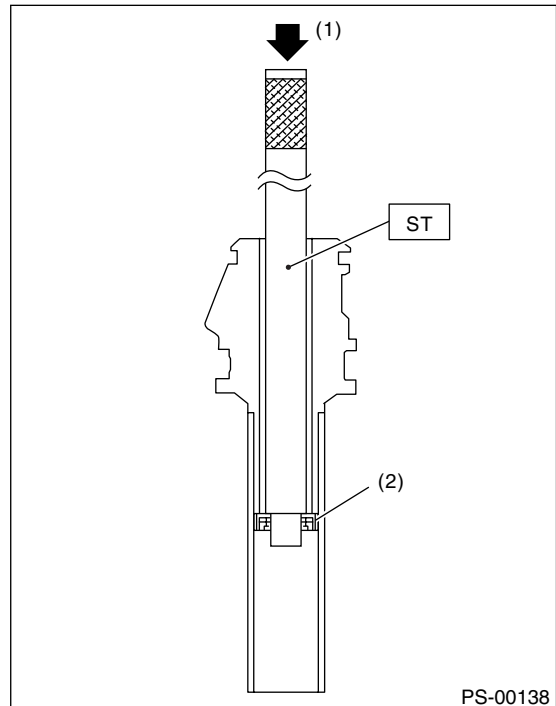

(1) Press
(2) Oil seal

• CONTROL VALVE ASSEMBLY

1) Disconnect the four pipes from gearbox.

NOTE:

Remove the pipes E and F as a single unit being fixed at clamp plate.

2) Secure the gearbox removed from the vehicle in vise using ST.

ST 926200000 STAND

CAUTION:

Secure the gearbox in a vise using ST as shown. Do not attempt to secure it without this ST.

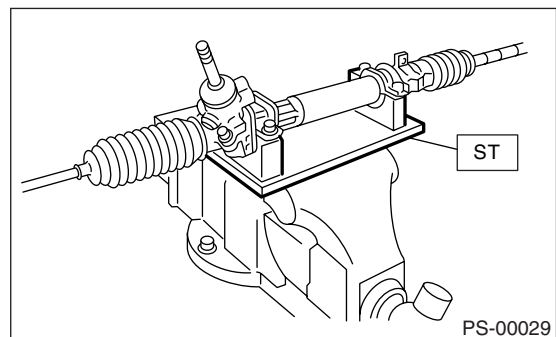

3) Using the ST, loosen the lock nut.

Steering Gearbox

POWER ASSISTED SYSTEM (POWER STEERING)

ST 926230000 SPANNER

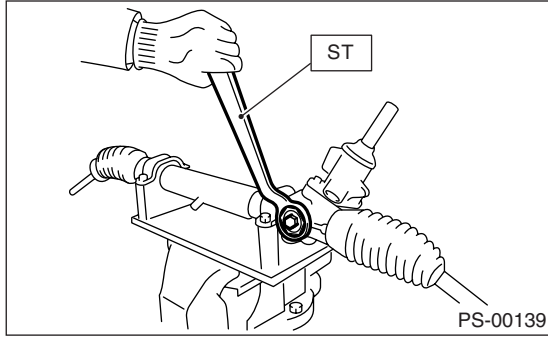

4) Tighten the adjusting screw until it no longer tightens.

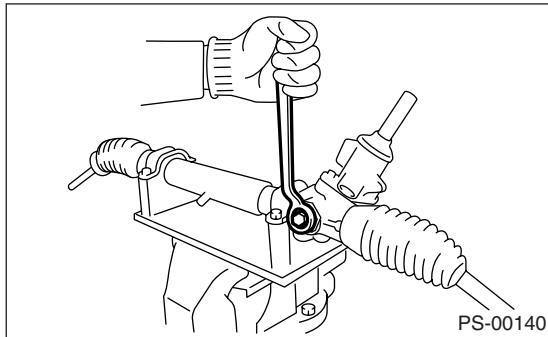

5) Loosen the adjusting screw, and then remove the spring and sleeve.

6) Remove the two bolts securing valve assembly.

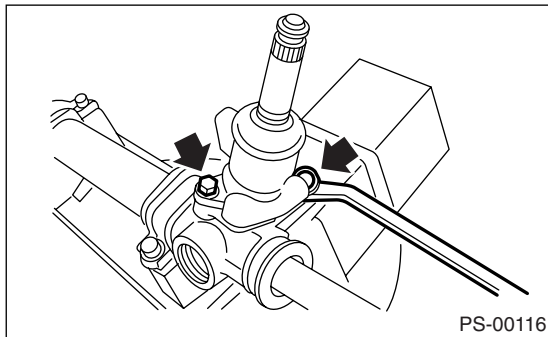

7) Carefully draw out the input shaft, and then remove the valve assembly.

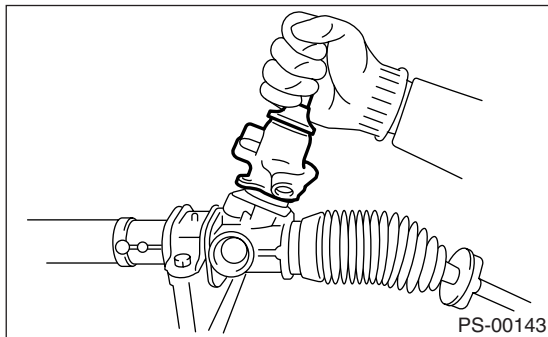

8) Slide the dust cover out.

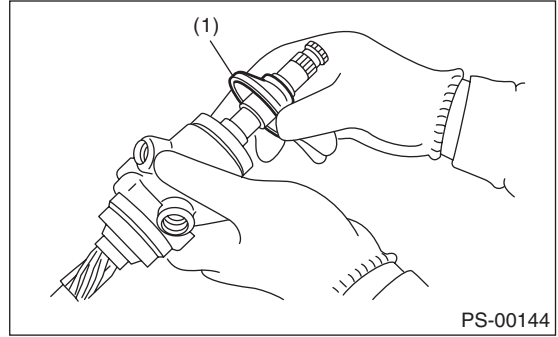

(1) Dust cover

9) Using a press remove the pinion and valve assembly from valve housing.

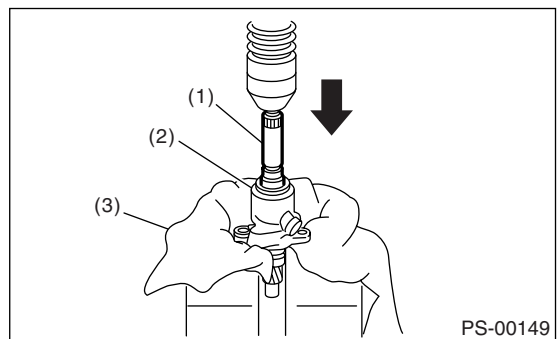

(1) Valve ASSY

(2) Valve housing

(3) Cloth

10) Using the ST and press, remove the dust seal, oil seal and special bearing from valve housing.

ST 34099FA120 INSTALLER & REMOVER SEAL

CAUTION:

- Do not apply force to the end surface of valve housing.
- Do not reuse the oil seal after removal.

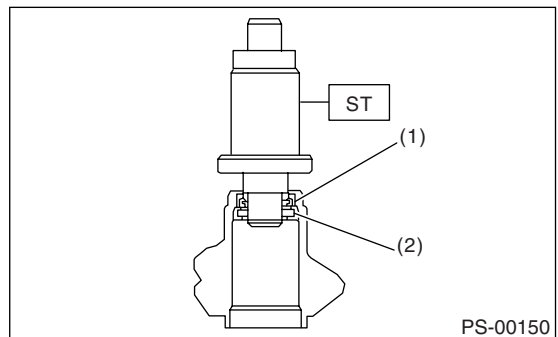

(1) Oil seal

(2) Special bearing

11) Remove the snap ring using snap ring pliers.

Steering Gearbox

POWER ASSISTED SYSTEM (POWER STEERING)

CAUTION:
Be careful not to scratch the pinion and valve assembly.

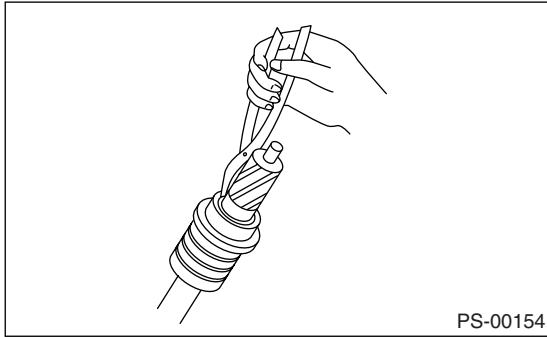

12) Press out the bearing together with the back up washer using pipe of I.D. 38.5 to 39.5 mm (1.516 to 1.555 in) and press.

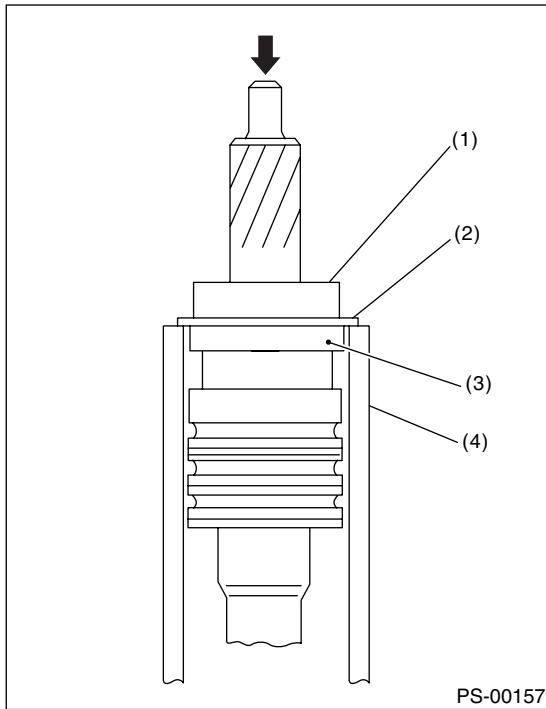

- (1) Bearing
- (2) Backing washer
- (3) Oil seal
- (4) Pipe

13) Remove the oil seal.

2. TURBO MODEL

1) Disconnect the pipes A and B from steering body and control valve housing.

2) Secure the gearbox removed from vehicle using a C-clamp.

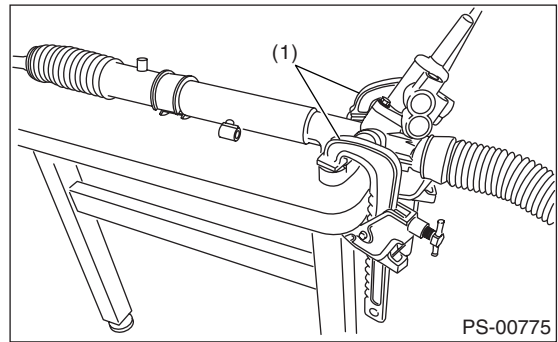

(1) C-clamp

3) Remove the tie-rod end and lock nut from gearbox.

4) Remove the clip on outside of boot using pliers, and then slide the boot to tie-rod end side.

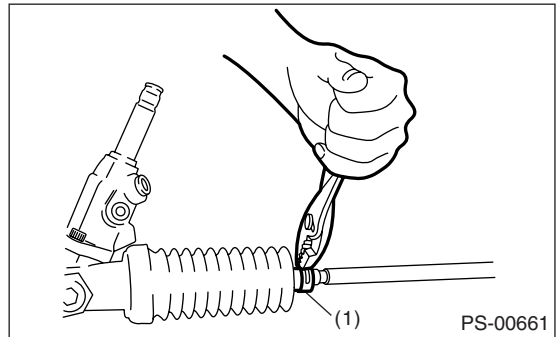

(1) Clip

5) Using flat tip screwdriver, remove the band from boot.

NOTE:

Check the boot for crack, damage or deterioration. Replace the boot with a new one if necessary.

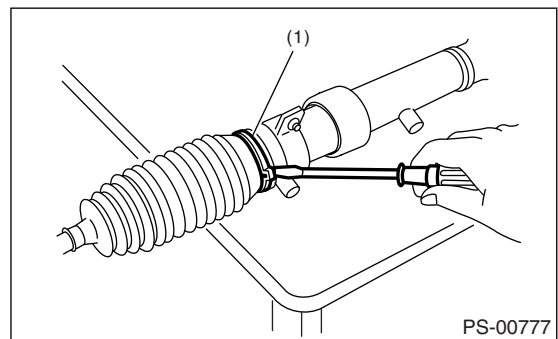

(1) Band

6) Using the ST, loosen lock nut.

Steering Gearbox

POWER ASSISTED SYSTEM (POWER STEERING)

ST 926230000 SPANNER

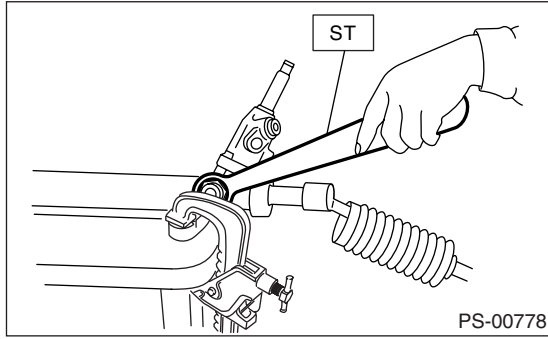

(1) Lock nut

7) Tighten the adjusting screw until it no longer tightens.

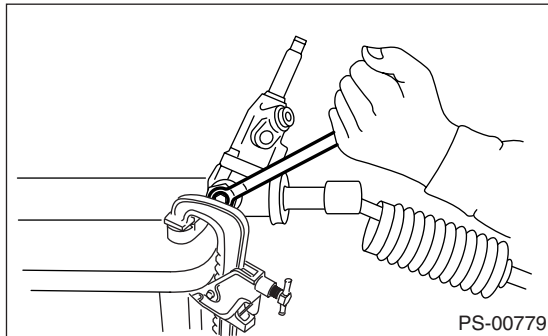

8) Using a wrench (32 mm width across flats) or adjustable wrench with cinching boot, remove the tie-rod.

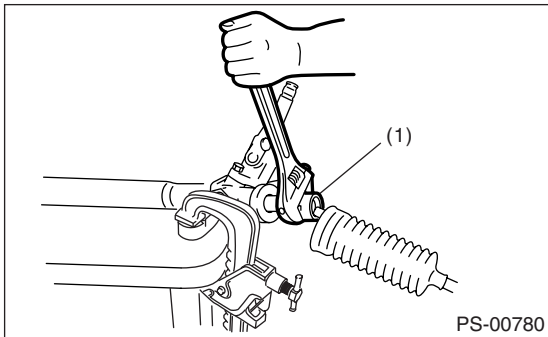

(1) Tie-rod

9) Loosen the adjusting screw, and then remove the spring and sleeve.

10) Clean the dirt of input shaft. Remove the dust cover taking care not to scratch the housing or input shaft and allow foreign matter to enter gear box interior.

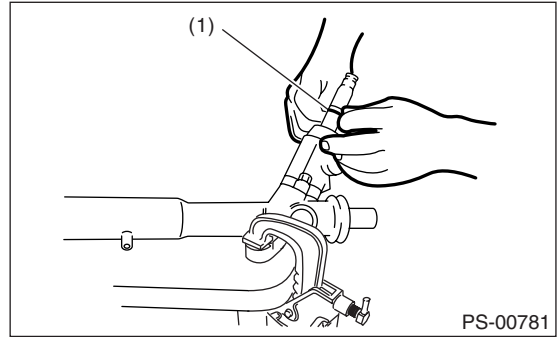

(1) Dust cover

11) Align the ST pin to plug hole to install. Rotate the ST counterclockwise to remove plug.
ST 34199AE090 PLUG WRENCH

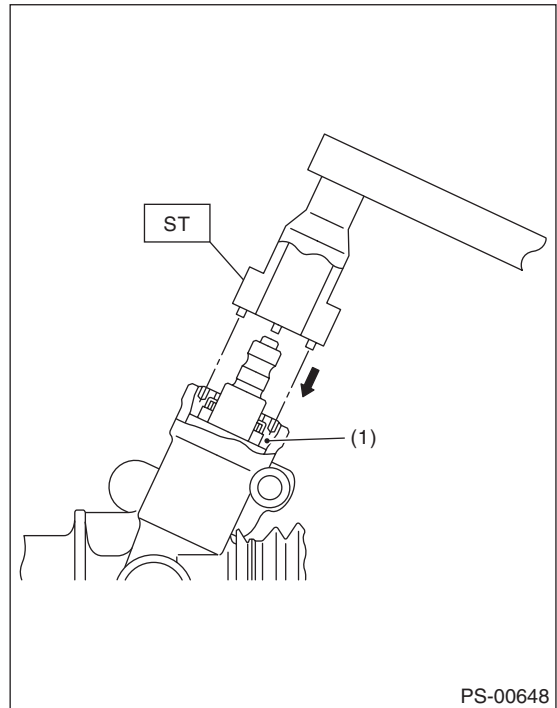

(1) Plug

Steering Gearbox

POWER ASSISTED SYSTEM (POWER STEERING)

12) Remove the valve assembly taking care not to scratch seal ring and valve housing inner surface.

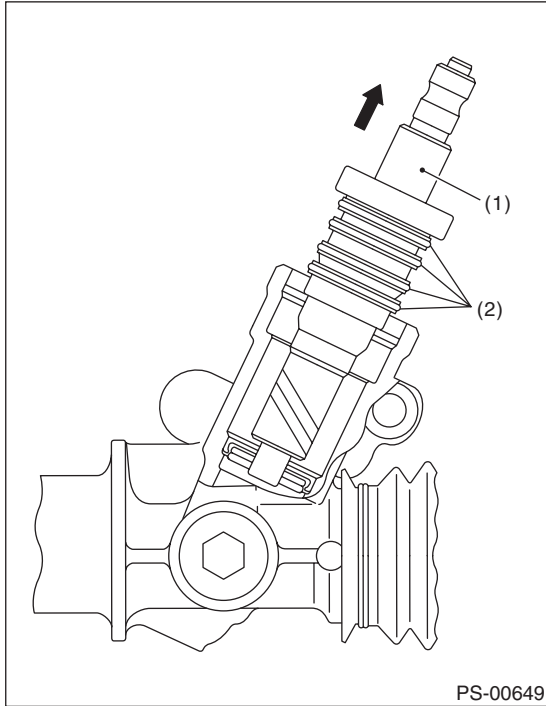

- (1) Valve ASSY
- (2) Seal ring

13) Remove the holder using a wrench (36 mm width across flats) or adjustable wrench.

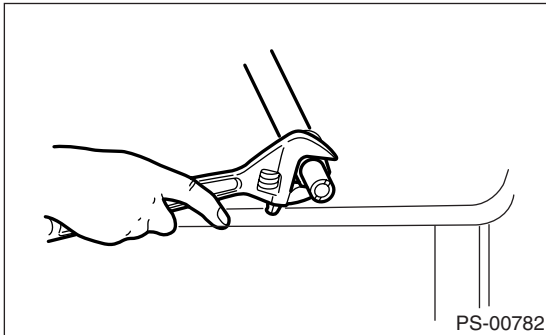

14) Install the ST on valve side of rack and press outer side oil seal out taking care not to contact rack with steering body inner surface.
ST 34199FE000 INSTALLER & REMOVER

NOTE:

Block the pipe connection of steering body to prevent fluid from flowing out.

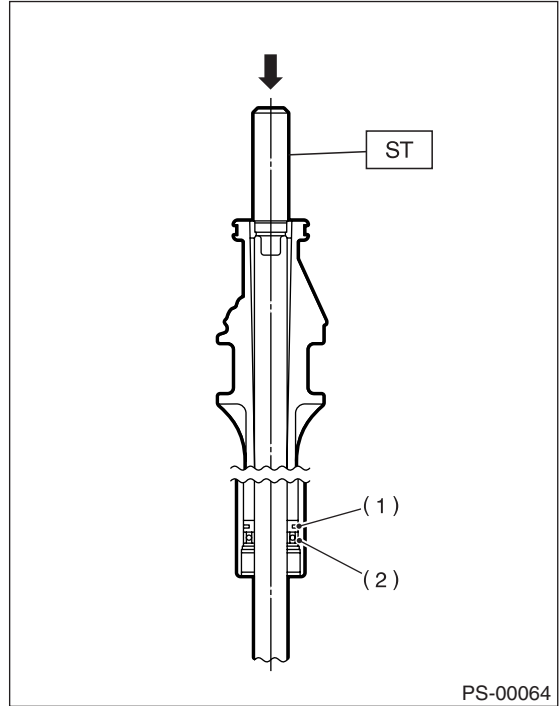

- (1) Rack piston
- (2) Outer side oil seal

15) Insert the ST from valve side and press back-up ring and oil seal out.
ST 34199FE010 REMOVER

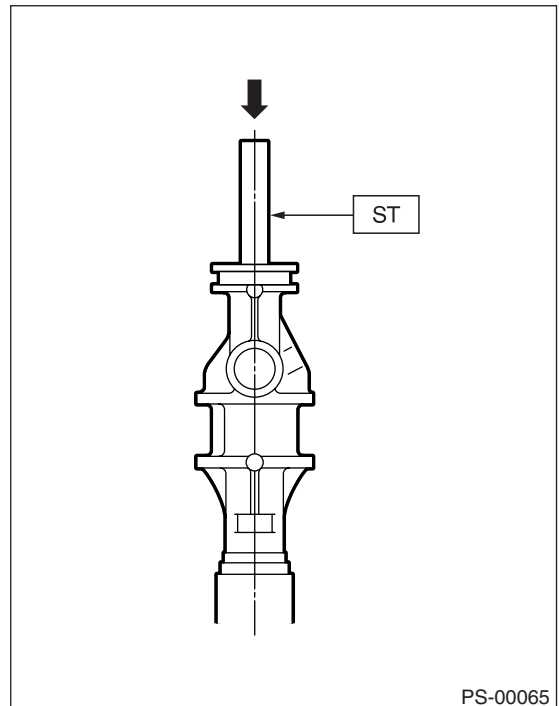

16) Using the ST1 and ST2, repair the cylinder's clinched sections.

Steering Gearbox

POWER ASSISTED SYSTEM (POWER STEERING)

ST1 34099FA080 PUNCH
ST2 34199FE020 BASE

NOTE:
Do not apply force on the plug edge surface.

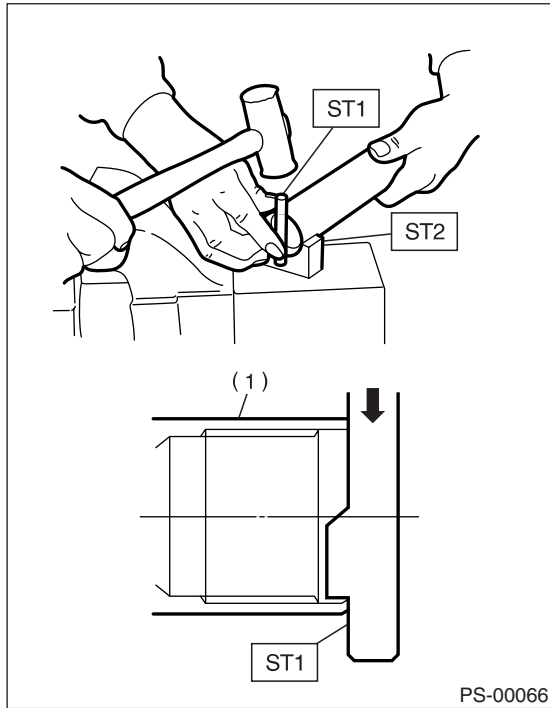

(1) Cylinder

17) If the cylinder edge is deformed in a convex shape, repair using an oil stone.

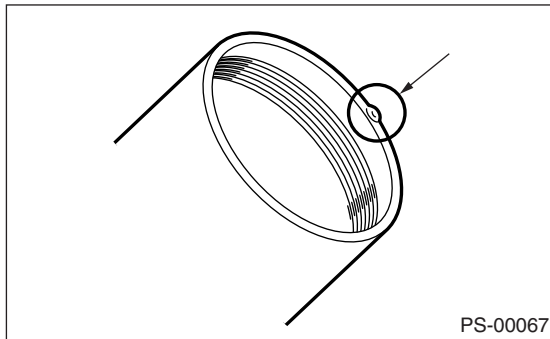

18) Remove the oil seal using ST and press from plug.

ST 34199AE100 PLUG OIL SEAL REMOVER

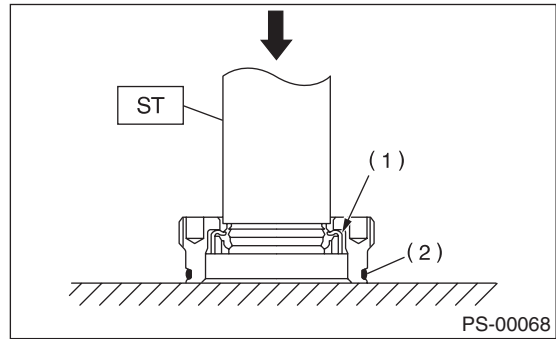

(1) Oil seal
(2) O-ring

19) Set the ST on drawing dimension.
ST 34199AE120 GEARBOX OIL SEAL RE-
MOVER

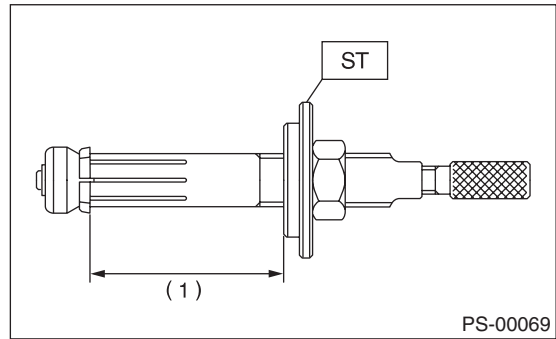

(1) 70 mm (2.76 in)

Steering Gearbox

POWER ASSISTED SYSTEM (POWER STEERING)

20) Set the stopper to gear box, and then insert the tip of ST to gear box.

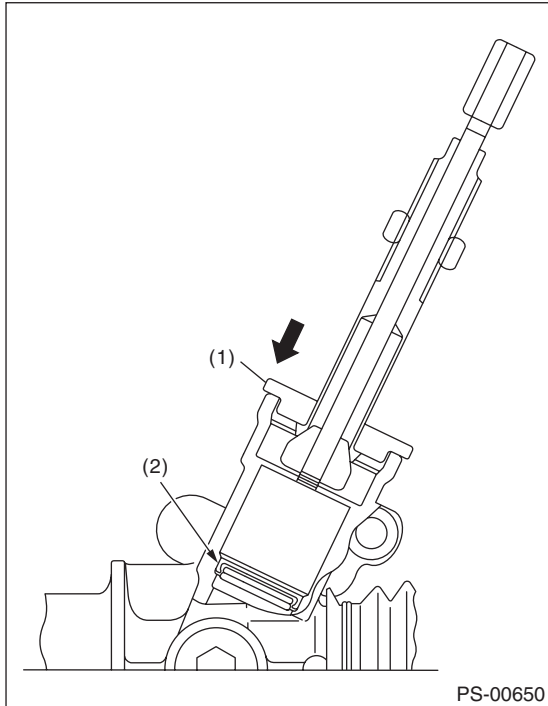

- (1) Stopper
- (2) Oil seal

21) By fixing the 2-surface width, press in by rotating the rod and attach to oil seal.

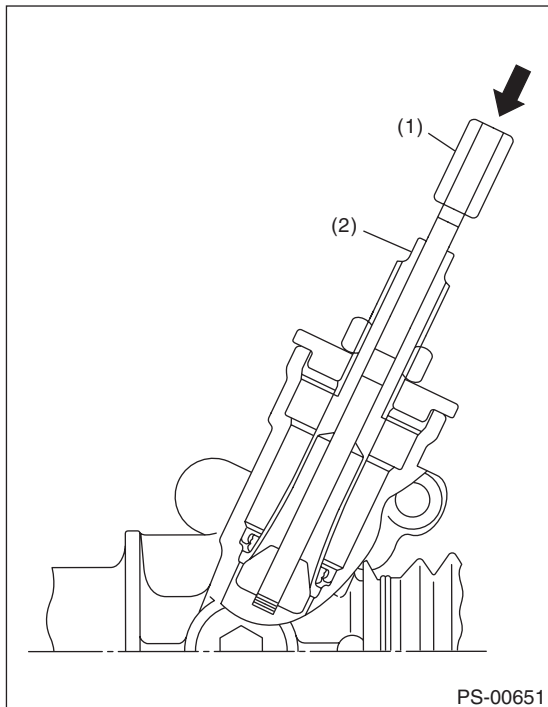

- (1) Rod
- (2) 2-surface width

22) While fixing the 2-surface width, pull out the oil seal by rotating nut.

CAUTION:

Take care not to scratch the gear box inner surface.

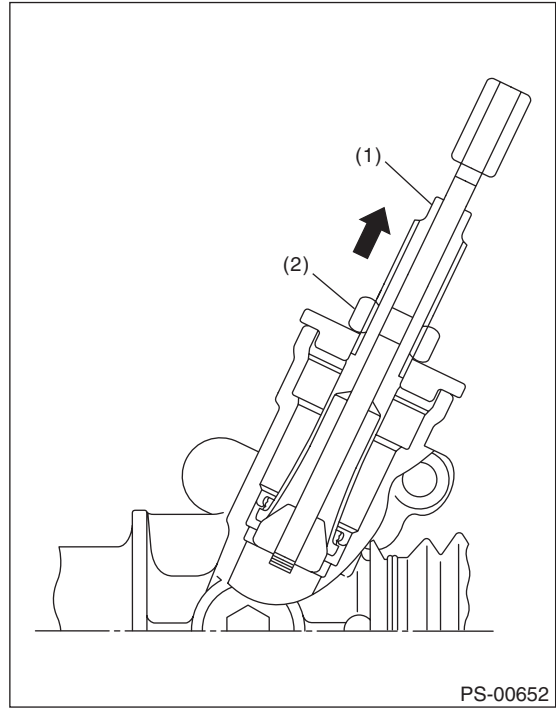

- (1) 2-surface width
- (2) Nut

23) Using a press, remove the bushing of gearbox installation portion.

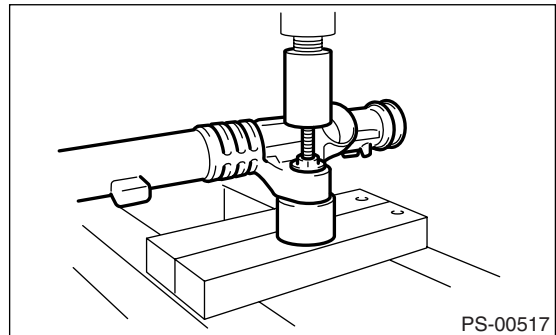

PS-00517

Steering Gearbox

POWER ASSISTED SYSTEM (POWER STEERING)

D: ASSEMBLY

1. NON-TURBO MODEL

• RACK HOUSING ASSEMBLY

CAUTION:

Use only genuine grease for the gearbox.

Specified grease for gearbox:

VALIANT GREASE M-2 (Part No. 003608001)

- 1) Apply power steering fluid to a new oil seal.
 - 2) Install the oil seal in correct position as shown in the figure. Push the oil seal using a press until portion A of ST contacts face of B.
- ST 34099FA110 INSTALLER

CAUTION:

Be careful not to damage or scratch the cylinder inner wall.

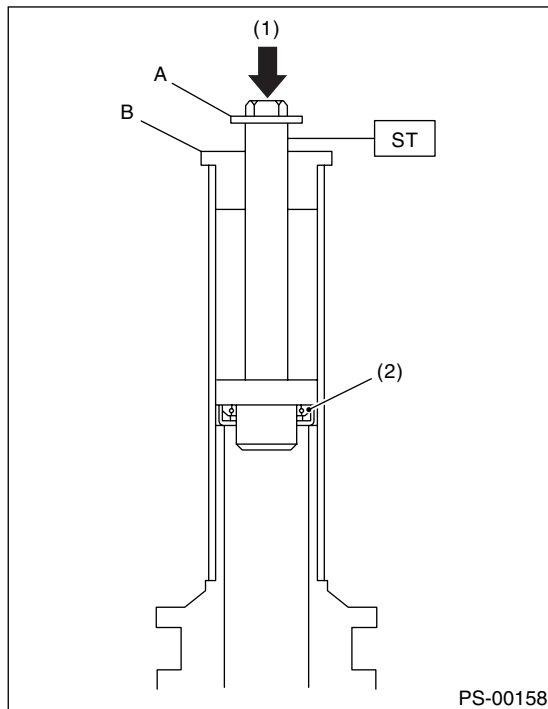

- (1) Press
(2) Oil seal

- 3) Fix the rack housing in vise using ST.
ST 926200000 STAND

NOTE:

- When fixing the rack housing in vise, be sure to use this special tool. Do not fix rack housing in vise using pad such as aluminum plates, etc.
- When using the old rack housing, be sure to clean and remove rust before assembling. Check pinion housing bushing carefully.

- 4) Fit the ST over toothed portion of rack assembly, and check for binding or irregular insertion. If any deformation is noted on flats at the end of rack, shape by using file, and wash with cleaning fluid.
ST 926390001 COVER & REMOVER ASSY

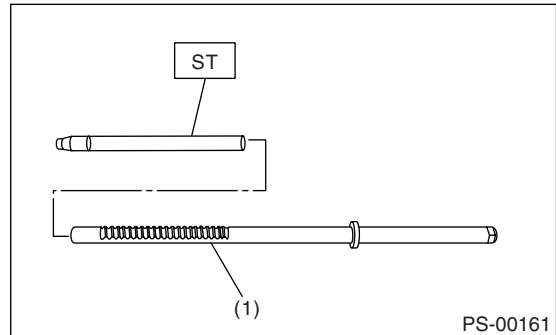

- (1) Rack ASSY

- 5) Apply genuine grease to the teeth of thoroughly washed rack assembly, and then fit the ST over the toothed portion.

CAUTION:

- Be careful not to block the air passage with grease. Remove excessive grease.
- After fitting cover, check the air passage hole for clogging. If clogged, open by removing grease from the hole.

- 6) Before inserting the rack assembly, apply a coat of specified power steering fluid to the surfaces of ST and rack piston.

- 7) Insert the rack assembly into rack housing from cylinder side, and then remove the ST after it has passed completely through oil seal.

- 8) Fit the ST1 and ST2 over the end of rack, and then install a new rack bushing.

ST1 926400000 GUIDE
ST2 927660000 GUIDE

CAUTION:

- If burrs or nicks are found on this guide and rack shaft portion, remove by filing.

Steering Gearbox

POWER ASSISTED SYSTEM (POWER STEERING)

- Dip the rack bushing in specified power steering fluid before installing, and pay attention not to damage O-ring and oil seal.

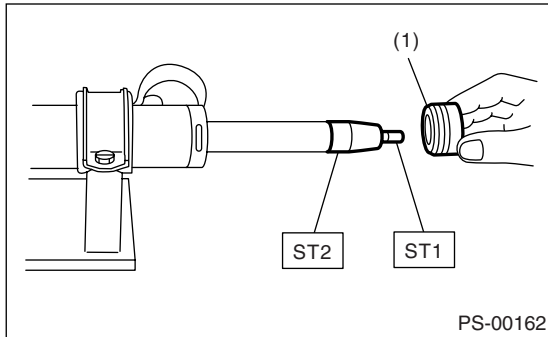

(1) Rack bushing ASSY

9) Insert the rack stopper into the cylinder tube until internal groove (on cylinder side) is aligned with external groove (on rack stopper). Turn the rack stopper with ST so that the rack stopper hole is seen through cylinder slits.

10) Insert the rack stopper into the rack housing, and then wrap a new circlip using a sharp pointed pliers to secure the rack stopper in position.

CAUTION:

Be careful not to scratch the rack while winding circlip.

NOTE:

Rotate the wrench another 90 to 180° after end of circlip has been wrapped in.

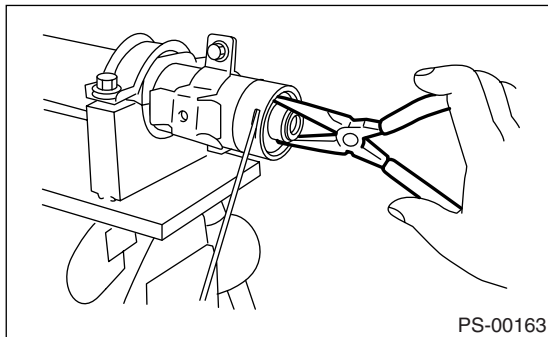

- 11) Apply genuine grease to dust cover, and then install the dust cover to valve assembly.

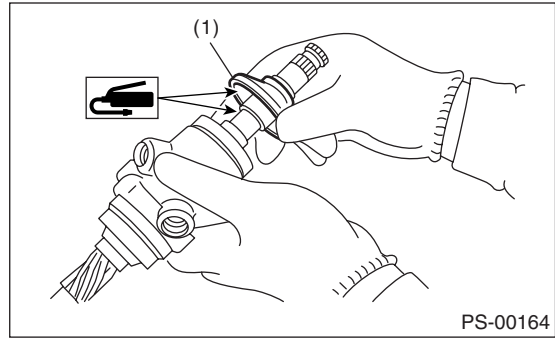

(1) Dust cover

- 12) Apply genuine grease to the pinion gear and bearing of valve assembly.

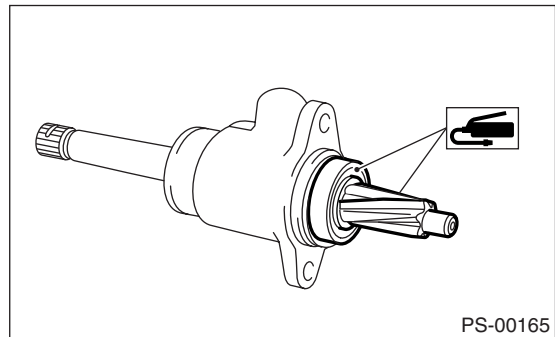

- 13) Install a new gasket on valve assembly. Insert the valve assembly into place while facing rack teeth toward pinion.

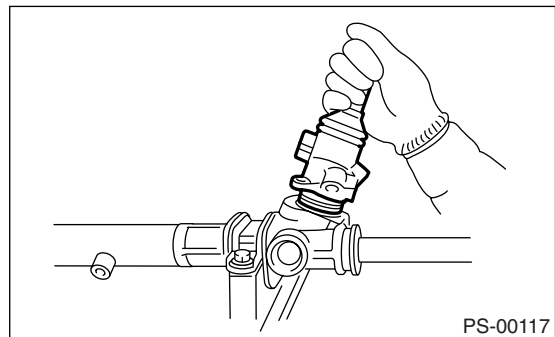

- 14) Tighten the bolts alternately to secure valve assembly.

Tightening torque:

25 N·m (2.5 kgf-m, 18.1 ft-lb)

CAUTION:

Be sure to alternately tighten the bolts.

- 15) Temporarily install the rack, and then operate it from lock to lock two or three times to make it fit in. Remove the grease blocking air vent hole.

Steering Gearbox

POWER ASSISTED SYSTEM (POWER STEERING)

CAUTION:

If operating the rack from lock to lock without installing tie-rod, it may damage the oil seal. Always install the tie-rods LH and RH.

16) Apply a coat of grease to the sliding surface of sleeve and seating surface of spring, and then insert sleeve into steering body.

Charge the adjusting screw with grease, and then insert the spring into adjusting screw and install on steering body.

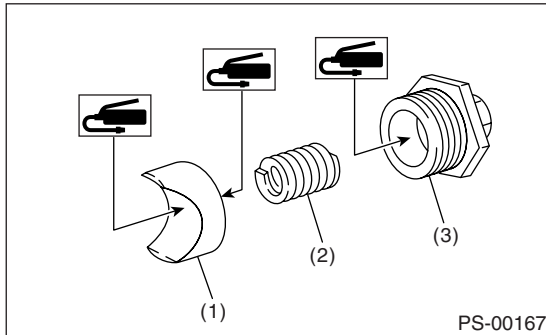

- (1) Sleeve
- (2) Spring
- (3) Adjusting screw

17) Tighten the adjusting screw to specified torque.

Tightening torque:

7.4 N·m (0.75 kgf-m, 5.4 ft-lb)

18) After tightening to the specified tightening torque, loosen it by 25°.

19) Remove the tie-rod.

20) Verify that play is within specified value. <Ref. to PS-51, SERVICE LIMIT, INSPECTION, Steering Gearbox.>

21) Loosen the adjusting screw, and then apply liquid gasket to at least 1/3 of the entire perimeter of adjusting screw thread.

Liquid gasket:

THREE BOND 1141 (Part No. 004403006)

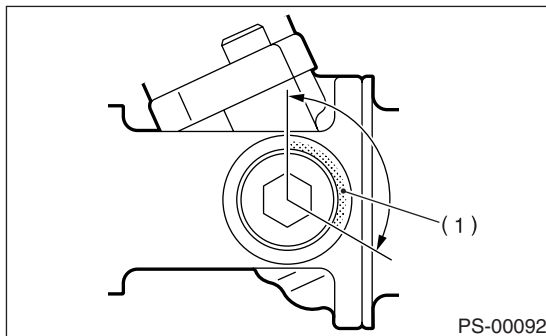

- (1) Apply liquid gasket to at least 1/3 of entire perimeter.

22) Tighten the adjusting screw to specified torque.

Tightening torque:

7.4 N·m (0.75 kgf-m, 5.4 ft-lb)

23) After tightening to the specified tightening torque, loosen it by 25°.

24) Install the lock nut. While holding the adjusting screw with a wrench, tighten lock nut using ST. ST 926230000 SPANNER

Tightening torque (Lock nut):

40 N·m (4.1 kgf-m, 29.5 ft-lb)

NOTE:

Hold the adjusting screw with a wrench to prevent it from turning while tightening lock nut.

25) Extend the rack approx. 40 mm (1.57 in) beyond side of steering body.

26) Install the tie-rod and a new lock washer into rack.

Tightening torque:

78 N·m (8.0 kgf-m, 57.9 ft-lb)

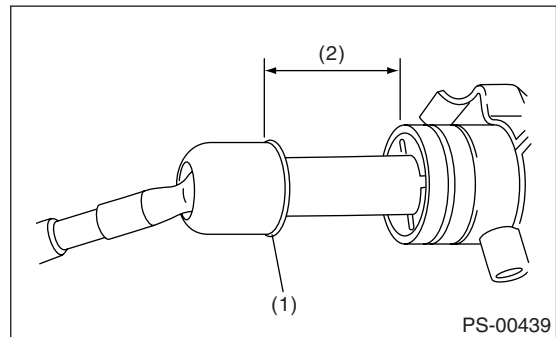

- (1) Lock washer
- (2) Approx. 40 mm (1.57 in)

27) Bend the lock washer.

Steering Gearbox

POWER ASSISTED SYSTEM (POWER STEERING)

CAUTION:
Be careful not to scratch the rack when bending lock washer.

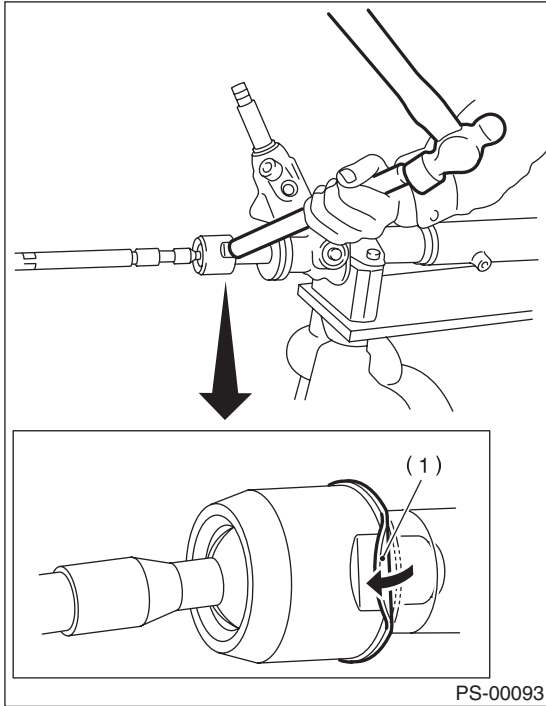

(1) Lock washer

28) Apply a coat of grease to the tie-rod groove, and then install the boot to housing.

NOTE:
Make sure that the boot is installed without unusual inflation or deflation.

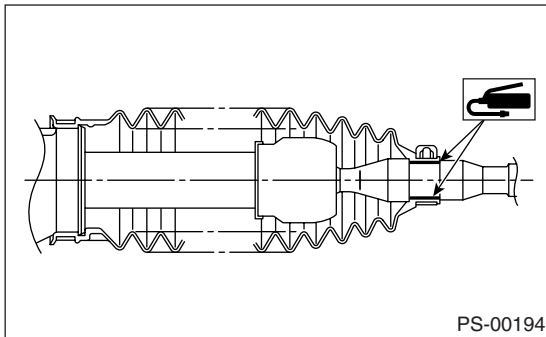

29) Install a new boot band. Using band clamp pliers, caulk the boot band until caulking part clearance is 2 mm (0.079 in) or less.

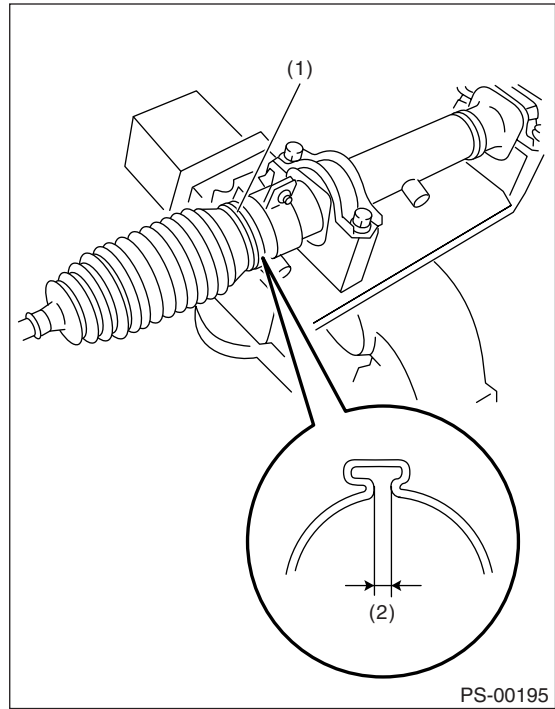

(1) Boot band
(2) 2 mm (0.079 in) or less

30) Fix the boot end with clip (small).

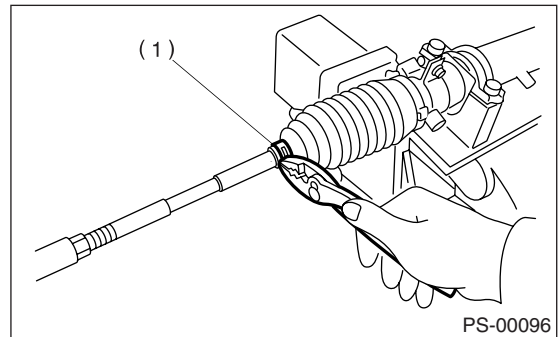

(1) Clip

31) After installing, check the boot end is positioned into groove on tie-rod.

32) If the tie-rod end was removed, screw in the lock nut and tie-rod end to screwed portion of tie-rod, and then tighten the lock nut temporarily in a position as shown in the figure.

Steering Gearbox

POWER ASSISTED SYSTEM (POWER STEERING)

Installed tie-rod length L:
15 mm (0.59 in)

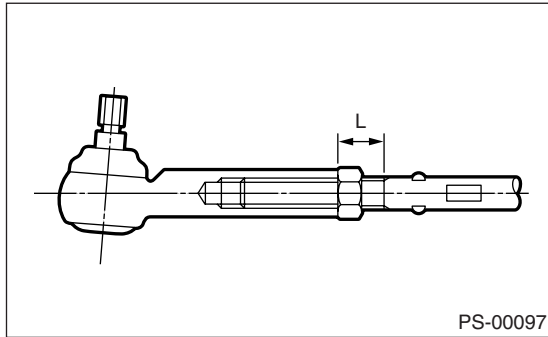

- 33) Inspect the gearbox as follows:
"A" Holding the tie-rod end, repeat lock to lock two or three times as quickly as possible.
"B" Holding the tie-rod end, turn it slowly at a radius one or two times as large as possible.
After all, make sure that the boot is installed in specified position without deflation.

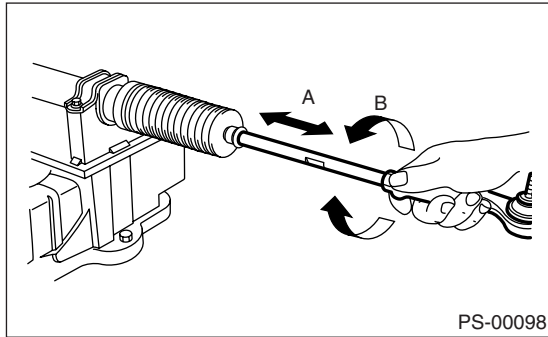

- 34) Remove the gearbox from ST.
ST 926200000 STAND
35) Install the four pipes on gearbox.
(1) Connect the pipe A and B to four pipe joints of gearbox.

Tightening torque:
13 N·m (1.3 kgf·m, 9.4 ft·lb)

- (2) Connect the pipe E and F to gearbox.

Tightening torque:
Pipe E: 15 N·m (1.5 kgf·m, 10.8 ft·lb)
Pipe F: 25 N·m (2.5 kgf·m, 18.1 ft·lb)

• CONTROL VALVE ASSEMBLY

Specified steering grease:
VALIANT GREASE M-2 (Part No. 003608001)

- 1) Clean all parts and tools before reassembling.

- 2) Apply a coat of specified power steering fluid to the inner wall of valve housing.

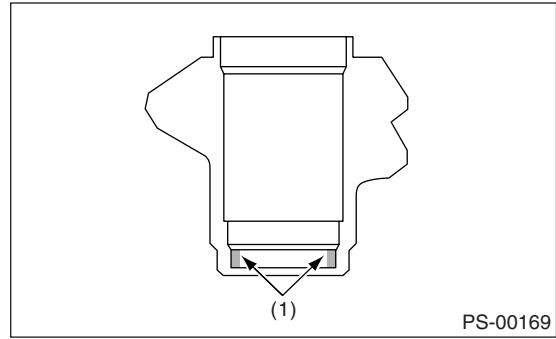

- (1) Apply fluid.

- 3) Attach the ST2 to ST1.
ST1 34099FA120 INSTALLER & REMOVER SEAL

ST2 34099FA130 INSTALLER SEAL

- 4) To avoid scratching the oil seal, apply a coat of grease to the contact surface of installer and oil seal.

- 5) Verify the oil seal direction.

Attach the oil seal to installer and position in valve housing before pressing into place.

- 6) Press the oil seal into place using a press.

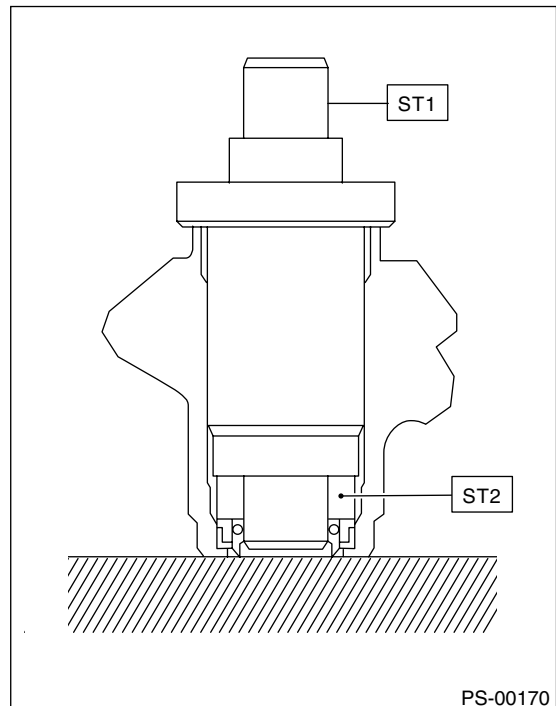

- 7) Attach the bearing to ST, and then position in value housing. Using the ST and press, install the special bearing in valve housing.

Steering Gearbox

POWER ASSISTED SYSTEM (POWER STEERING)

ST 34099FA120 INSTALLER & REMOVER SEAL

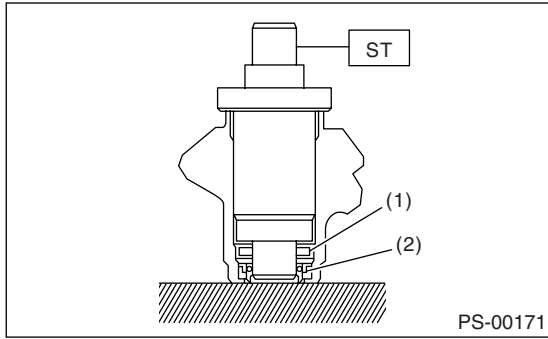

- (1) Special bearing
- (2) Oil seal

8) Put vinyl tape around the pinion shaft splines to protect oil seal from damage.

9) Fit the pinion and valve assembly into valve housing.

10) Secure the valve assembly to ST1 and ST2.

ST1 926370000 INSTALLER A

ST2 34099FA100 STAND BASE

11) Apply specified power steering fluid to oil seal and ST3.

12) Install the ST3 to pinion, and then insert the oil seal. Press the oil seal using a press until ST4 contacts face end of valve housing.

ST3 926360000 INSTALLER A

ST4 927620000 INSTALLER B

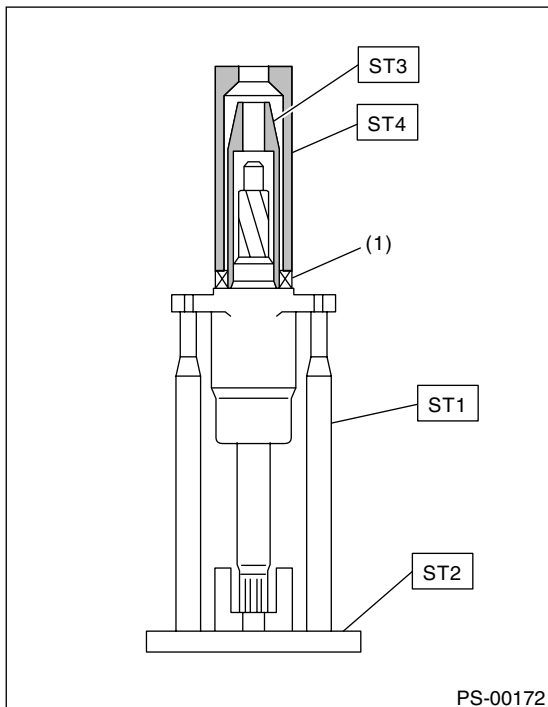

- (1) Oil seal

13) Remove the ST3, and then fit the back-up washer.

14) Force-fit the ball bearing using ST3.

ST1 926370000 INSTALLER A

ST2 34099FA100 STAND BASE

ST3 927640000 INSTALLER B

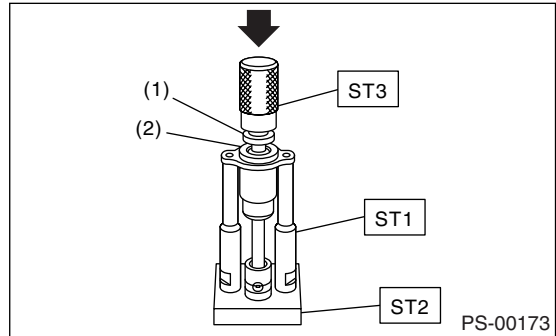

- (1) Ball bearing
- (2) Back-up washer

NOTE:

Be careful not to tilt the ball bearing during installation.

15) Install the snap ring using snap ring pliers.

NOTE:

Rotate the snap ring to check for proper installation.

16) Apply the specified grease to dust cover.

17) Install the dust cover on valve assembly.

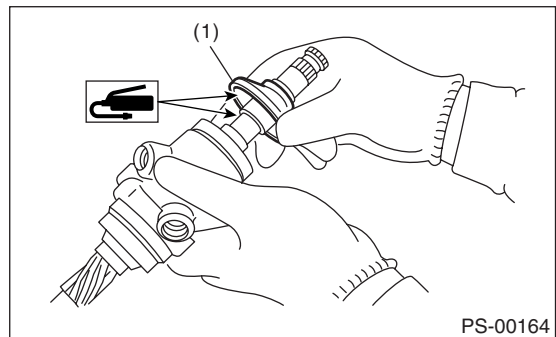

- (1) Dust cover

18) Apply genuine grease to the pinion gear and bearing of valve assembly.

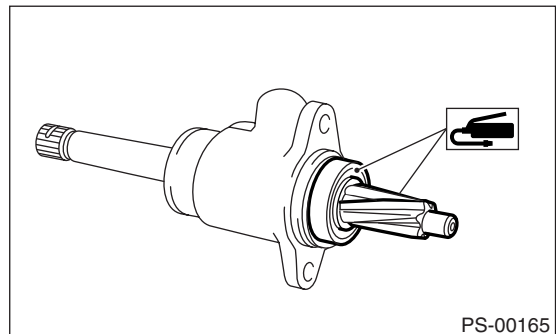

Steering Gearbox

POWER ASSISTED SYSTEM (POWER STEERING)

19) Install a new gasket on valve assembly. Insert the valve assembly into place while facing rack teeth toward pinion.

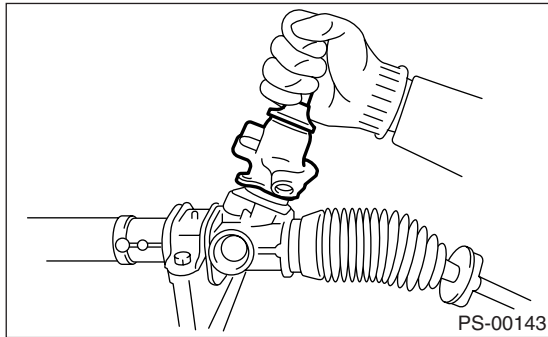

20) Tighten the bolts alternately to secure valve assembly.

Tightening torque:

25 N·m (2.5 kgf·m, 18.1 ft·lb)

CAUTION:

Be sure to alternately tighten the bolts.

21) Apply a coat of grease to the sliding surface of sleeve and seating surface of spring, and then insert sleeve into steering body.

Charge the adjusting screw with grease, and then insert the spring into adjusting screw and install on steering body.

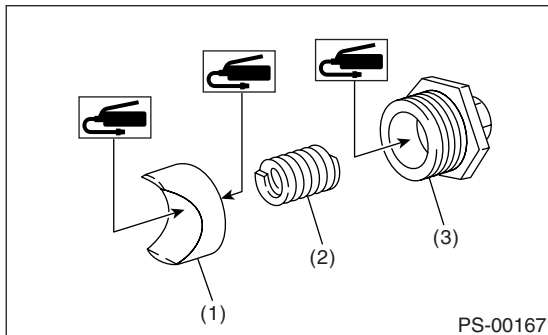

- (1) Sleeve
- (2) Spring
- (3) Adjusting screw

22) Tighten the adjusting screw to specified torque.

Tightening torque:

7.4 N·m (0.75 kgf·m, 5.4 ft·lb)

23) After tightening to the specified tightening torque, loosen it by 25°.

24) Verify that play is within specified value. <Ref. to PS-51, SERVICE LIMIT, INSPECTION, Steering Gearbox.>

25) Loosen the adjusting screw, and then apply liquid gasket to at least 1/3 of the entire perimeter of adjusting screw thread.

Liquid gasket:

THREE BOND 1141 (Part No. 004403006)

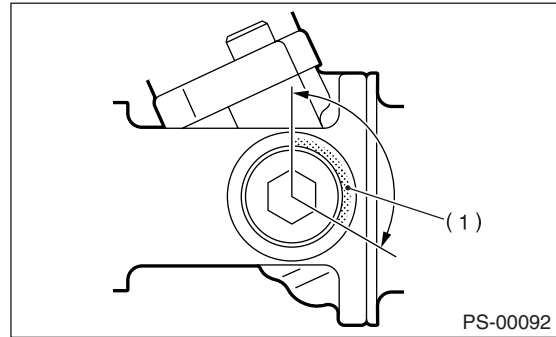

- (1) Apply liquid gasket to at least 1/3 of entire perimeter.

26) Tighten the adjusting screw to specified torque.

Tightening torque:

7.4 N·m (0.75 kgf·m, 5.4 ft·lb)

27) After tightening to the specified tightening torque, loosen it by 25°.

28) Install the lock nut. While holding the adjusting screw with a wrench, tighten lock nut using ST. ST 926230000 SPANNER

Tightening torque (Lock nut):

40 N·m (4.1 kgf·m, 29.5 ft·lb)

NOTE:

Hold the adjusting screw with a wrench to prevent it from turning while tightening lock nut.

29) Remove the gearbox from ST.

30) Install the four pipes on gearbox.

- (1) Connect the pipe A and B to the gearbox.

Tightening torque:

13 N·m (1.3 kgf·m, 9.4 ft·lb)

- (2) Connect the pipe E and F to gearbox.

Tightening torque:

Pipe E: 15 N·m (1.5 kgf·m, 10.8 ft·lb)

Pipe F: 25 N·m (2.5 kgf·m, 18.1 ft·lb)

2. TURBO MODEL AND STI MODEL

1) Using a press, install the bushing to gearbox installation portion.

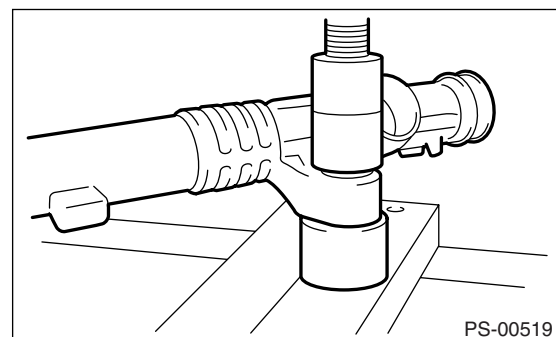

Steering Gearbox

POWER ASSISTED SYSTEM (POWER STEERING)

2) Apply a coat of grease to inside and outside of new oil seal.

Specified steering grease:

VALIANT GREASE M-2 (Part No. 003608001)

3) Verify the oil seal direction and installation position. Using the ST and press, press fit the oil seal to gear box.

ST 34199AE130 GEARBOX OIL SEAL INSTALLER

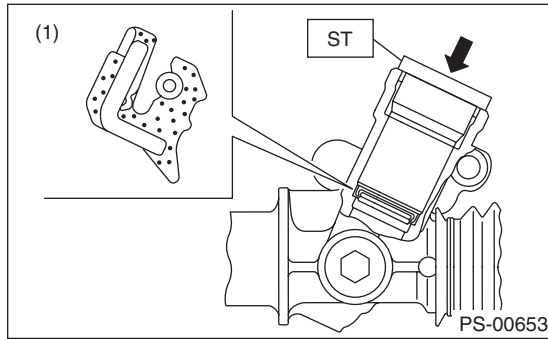

(1) Oil seal

4) Using a C-clamp, attach the steering body as shown in the figure. Apply a coat of grease to needle bearing.

CAUTION:

Ensure the needle bearing is free from defects. If it is faulty, replace the steering body with a new one.

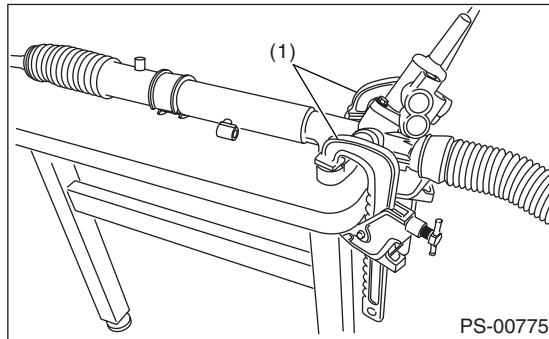

(1) C-clamp

5) Using the ST-B and ST-C, attach the oil seal to ST-A.

ST 34199FE040 INSTALLER A, B, C

NOTE:

Face the oil seal in direction shown in the figure.

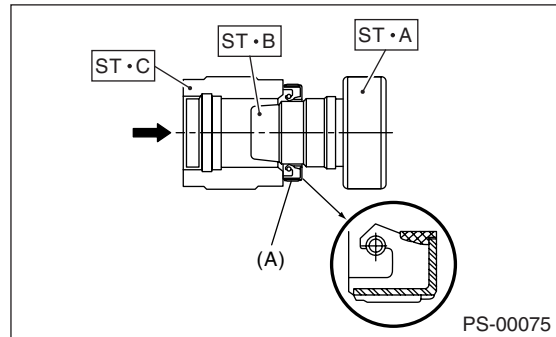

(A) Oil seal

6) Insert the ST-A with oil seal assembled, through gear side of rack. Remove the oil seal from ST-A near piston, and then remove the ST-A from rack.

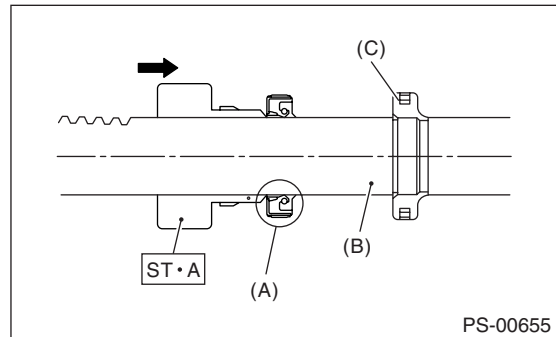

(A) Oil seal
(B) Rack
(C) Piston

7) Install the back-up washer from gear side of rack.

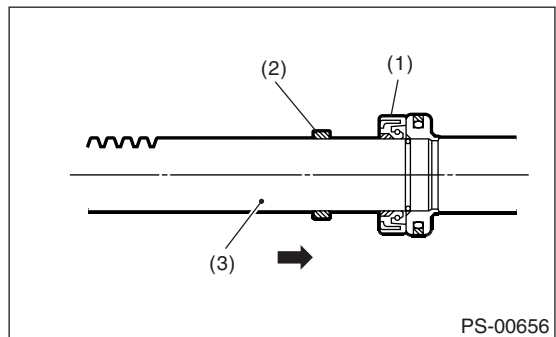

(1) Oil seal
(2) Back-up washer
(3) Rack

8) Equally apply a thin coat of grease to the rack, then install the oil seal.

Steering Gearbox

POWER ASSISTED SYSTEM (POWER STEERING)

CAUTION:

Be careful not to scratch the oil seal lips with piston's inner ring section.

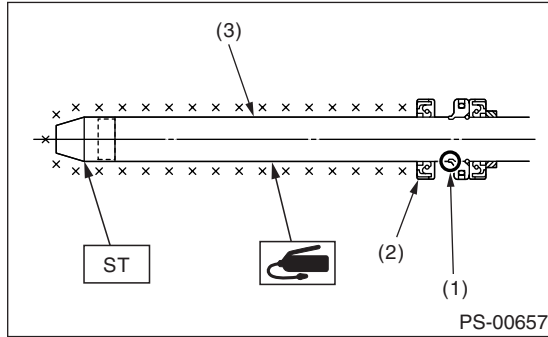

- (1) Rack piston inner ring
- (2) Outer side oil seal
- (3) Rack

9) Apply a coat of grease to the grooves in rack, sliding surface of sleeve and sealing surface of piston. Install the ST on end of steering body cylinder. Then insert the rack into steering body from cylinder side.

ST 34199FE050 GUIDE

CAUTION:

Do not allow grease to block the air vent hole on rack.

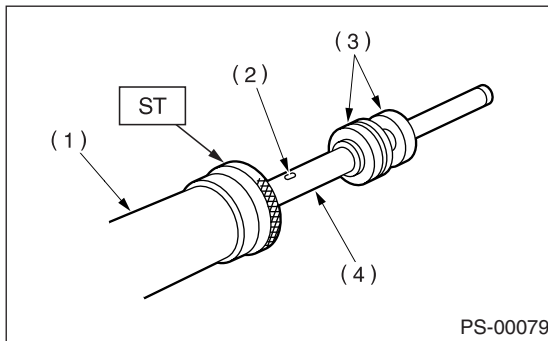

- (1) Cylinder side of steering body
- (2) Air vent hole
- (3) Oil seal
- (4) Rack

10) Using the press, slowly press the inner side oil seal until distance between the ST and end of rack becomes 65 mm (2.56 in).

ST 34199FE050 GUIDE

CAUTION:

Ensure the ST's inner wall is free of scratches since it may damage the oil seal.

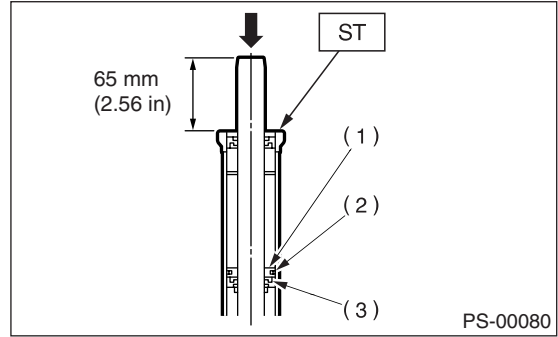

- (1) Rack piston
- (2) Inner side oil seal
- (3) Back-up ring

11) Pass the ST2 and pipe through rack and press outer side oil seal until ST1 is in contact with ST2 using press.

ST1 34199FE050 GUIDE

ST2 34199FE060 INSTALLER

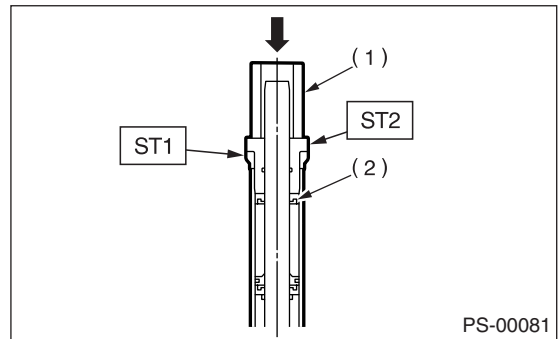

- (1) Pipe
- (2) Outer side oil seal

12) Install a new holder to cylinder side of steering body.

Tightening torque:

90 N·m (9.0 kgf-m, 65.1 ft-lb)

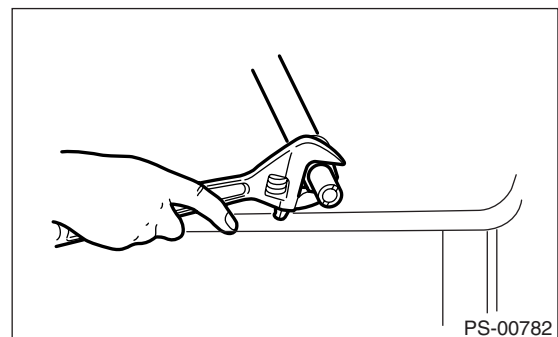

Steering Gearbox

POWER ASSISTED SYSTEM (POWER STEERING)

13) Install the ST to rack cylinder. Using a press, press the ST until its groove is aligned with end of holder.

ST 34199FE000 INSTALLER & REMOVER

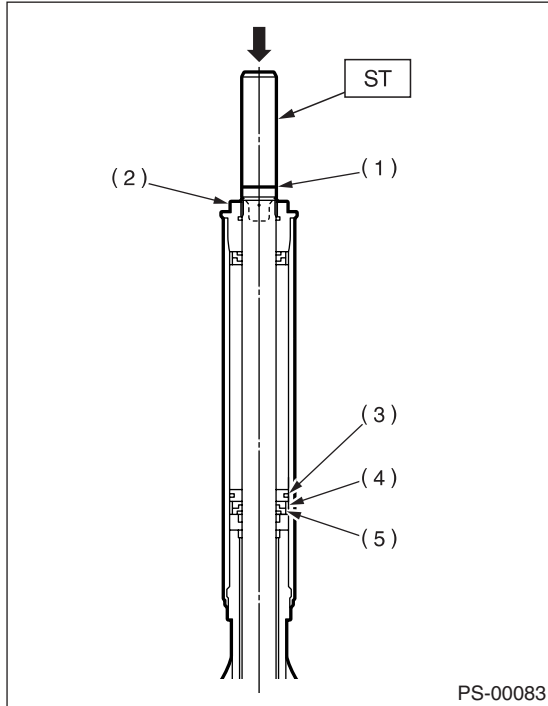

- (1) Groove
- (2) Holder
- (3) Rack piston
- (4) Oil seal
- (5) Back-up ring

14) Using the ST, clinch steering body cylinder at a point less than 3 mm (0.12 in) from holder.

CAUTION:

Be careful not to deform the holder.

ST 34099FA060 PUNCH HOLDER

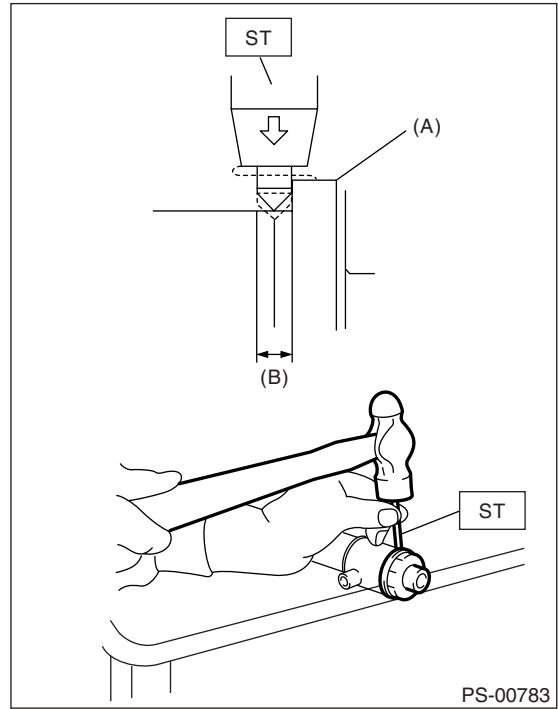

- (A) Holder
- (B) 3 mm (0.1 in)

15) Roll the vinyl tape on serration part of valve assembly, and then apply grease on the tape surface.

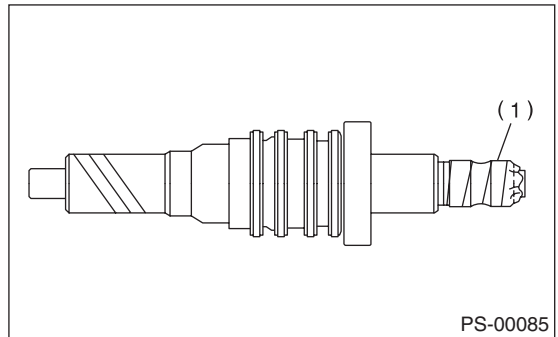

- (1) Vinyl tape

Steering Gearbox

POWER ASSISTED SYSTEM (POWER STEERING)

16) Apply a coat of grease on the gear teeth of valve assembly, and then attach the valve assembly taking care not to scratch oil seal and seal ring.

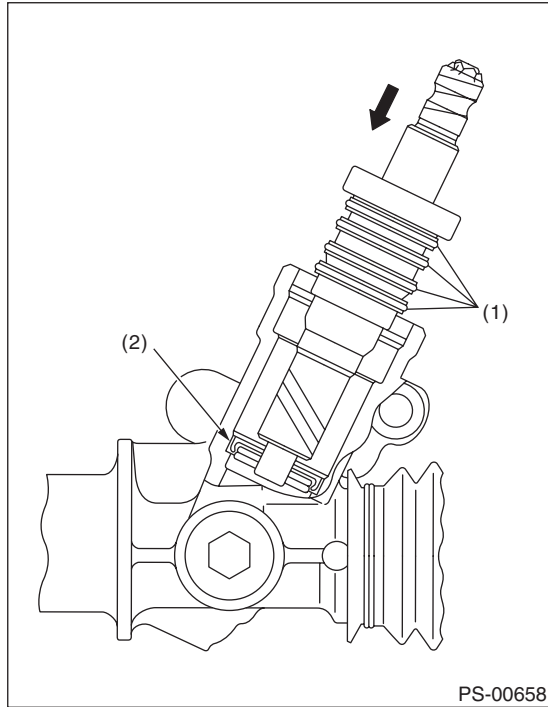

- (1) Seal ring
- (2) Oil seal

17) Apply grease on the oil seal circumference, and then press into the plug using ST and a press. Replace the plug circumference O-rings with new ones.

ST 34199AE110 PLUG OIL SEAL INSTALLER

CAUTION:

Pay attention to the oil seal direction, and attaching position.

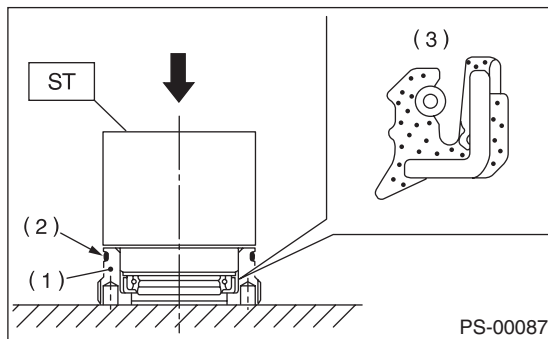

- (1) Plug
- (2) O-ring
- (3) Oil seal

18) Using the ST, install the plug.
ST 34199AE090 PLUG WRENCH

Tightening torque:

64 N·m (6.5 kgf·m, 47.0 ft·lb)

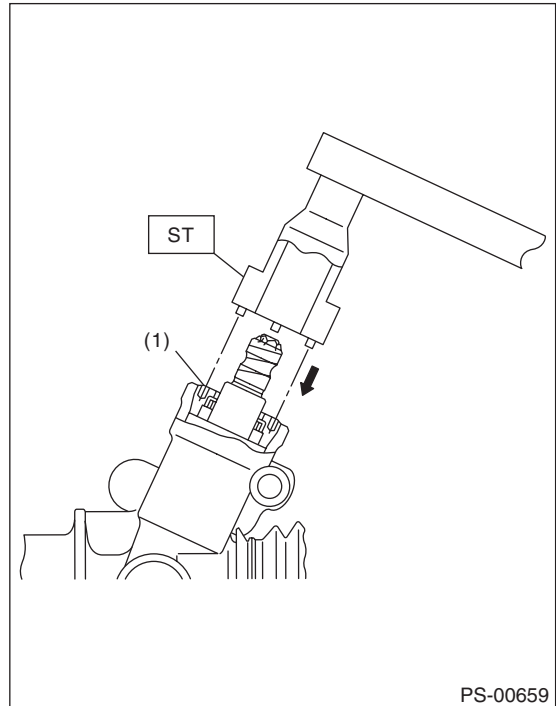

- (1) Plug

19) Install the dust cover. Remove the vinyl tape.

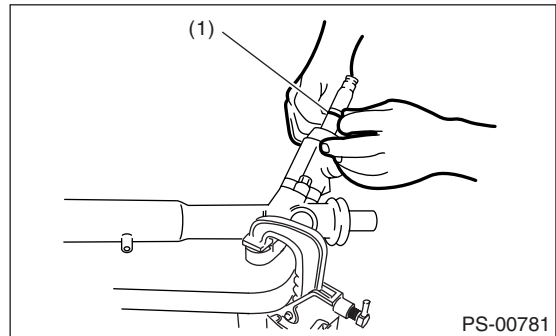

- (1) Dust cover

20) Temporarily install the rack, and then operate it from lock to lock two or three times to make it fit in. Remove the grease blocking air vent hole.

CAUTION:

If operating the rack from lock to lock without installing tie-rod, it may damage the oil seal. Always install the tie-rods LH and RH.

21) Apply a coat of grease to the sliding surface of seat pad, sleeve and seating surface of spring, and then insert sleeve into steering body.

Steering Gearbox

POWER ASSISTED SYSTEM (POWER STEERING)

Charge the adjusting screw with grease, and then insert the spring into adjusting screw and install on steering body.

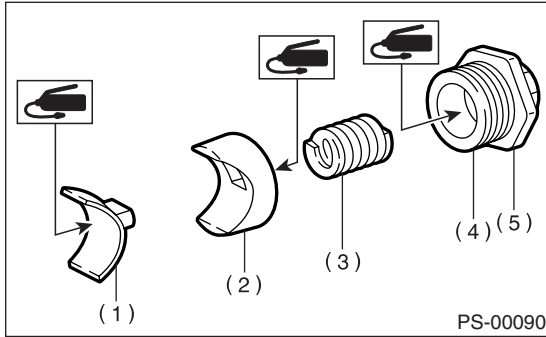

- (1) Seat pad
- (2) Sleeve
- (3) Spring
- (4) Adjusting screw
- (5) Lock nut

22) Tighten the adjusting screw to specified torque.

Tightening torque:

7.4 N·m (0.75 kgf-m, 5.4 ft-lb)

23) After tightening to the specified tightening torque, loosen it by 37°.

24) Remove the tie-rod.

25) Verify that play is within specified value. <Ref. to PS-51, SERVICE LIMIT, INSPECTION, Steering Gearbox.>

26) Loosen the adjusting screw, and then apply liquid gasket to at least 1/3 of the entire perimeter of adjusting screw thread.

Liquid gasket:

THREE BOND 1141 (Part No. 004403006)

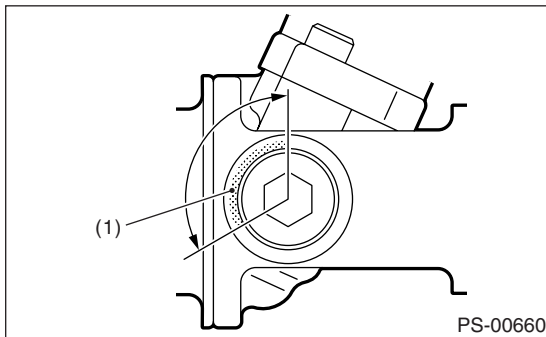

- (1) Apply liquid gasket to at least 1/3 of entire perimeter.

27) Tighten the adjusting screw.

Tightening torque:

9.8 N·m (1.0 kgf-m, 7.2 ft-lb)

28) After tightening to the specified tightening torque, loosen it.

29) Tighten the adjusting screw.

Tightening torque:

4.8 N·m (0.49 kgf-m, 3.5 ft-lb)

30) After tightening to the specified tightening torque, loosen it.

31) Tighten the adjusting screw.

Tightening torque:

4.8 N·m (0.49 kgf-m, 3.5 ft-lb)

32) After tightening to the specified tightening torque, loosen it by 37°.

33) Install the lock nut. While holding the adjusting screw with a wrench, tighten lock nut using ST.

ST 926230000 SPANNER

Tightening torque (Lock nut):

40 N·m (4.1 kgf-m, 29.5 ft-lb)

NOTE:

Hold the adjusting screw with a wrench to prevent it from turning while tightening lock nut.

34) Install the tie-rod into rack.

Tightening torque:

90 N·m (9.0 kgf-m, 65.1 ft-lb)

NOTE:

Check the mating face of rack and tie-rod for foreign material, dirt, dust and etc.

If required, clean the mating face.

35) Apply a coat of grease to the tie-rod groove, and then install the boot to housing.

NOTE:

Make sure that the boot is installed without unusual inflation or deflation.

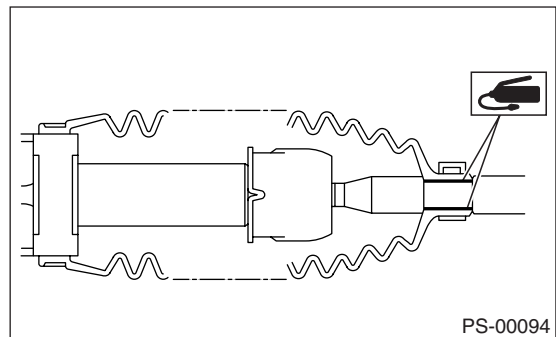

36) Caulk the boot so the space inside boot band caulking portion becomes 2 mm (0.08 in) or less.

Steering Gearbox

POWER ASSISTED SYSTEM (POWER STEERING)

NOTE:
Use a new boot band.

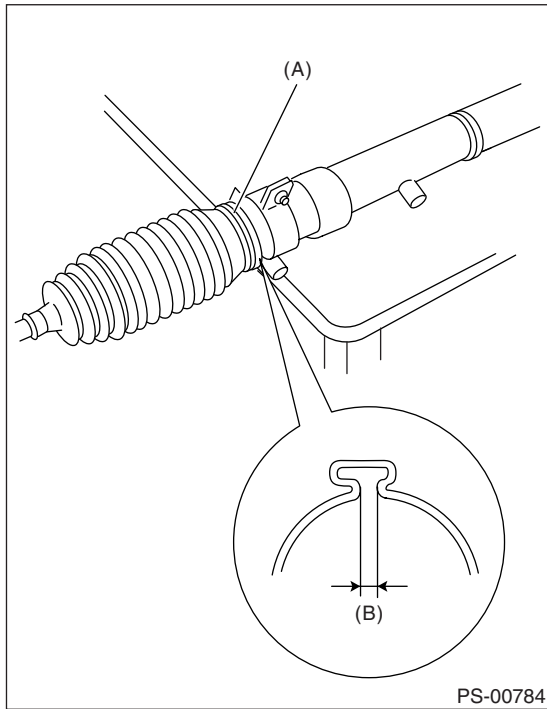

- (A) Boot band
- (B) Less than 2 mm (0.08 in)

37) Fix the boot end with clip (small).

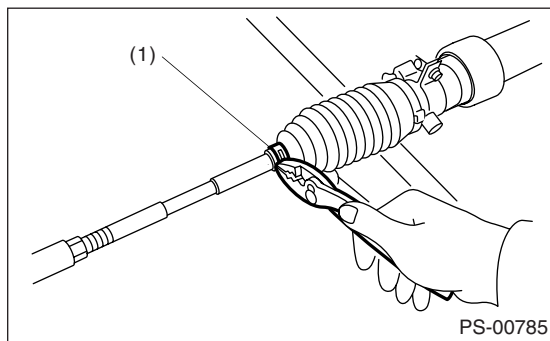

- (1) Clip

38) After installing, check the boot end is positioned into groove on tie-rod.

39) If the tie-rod end was removed, screw in the lock nut and tie-rod end to screwed portion of tie-rod, and then tighten the lock nut temporarily in a position as shown in the figure.

Installed tie-rod length L:

- Sedan:**
25 mm (0.98 in)
- Wagon:**
15 mm (0.59 in)

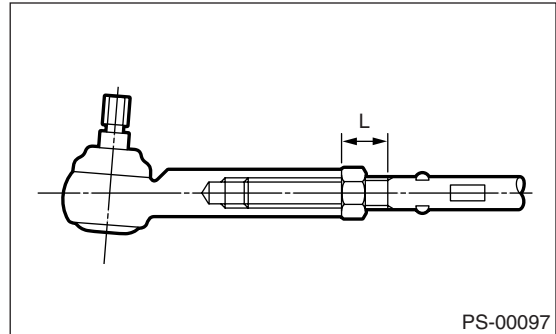

PS-00097

40) Inspect the gearbox as follows:
“A” Holding the tie-rod end, repeat lock to lock two or three times as quickly as possible.
“B” Holding the tie-rod end, turn it slowly at a radius one or two times as large as possible.
After all, make sure that the boot is installed in specified position without deflation.

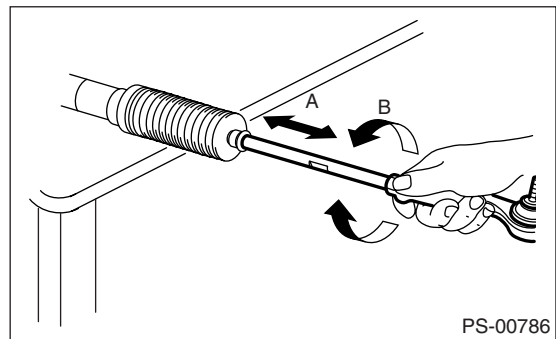

PS-00786

- 41) Remove the gearbox from ST.
ST 926200000 STAND
- 42) Install the four pipes on gearbox.
 - (1) Connect the pipe A and B to gearbox.

Tightening torque:

Housing side

20 N·m (2.0 kgf-m, 14.5 ft-lb)

Cylinder side

24 N·m (2.4 kgf-m, 17.4 ft-lb)

- (2) Connect the pipe G and H to gearbox.

Tightening torque:

15 N·m (1.5 kgf-m, 10.8 ft-lb)

Steering Gearbox

POWER ASSISTED SYSTEM (POWER STEERING)

E: INSPECTION

1. BASIC INSPECTION

1) Clean all disassembled parts, and check for wear, damage, or any other faults, then repair or replace as necessary.

2) When disassembling, check the inside of gearbox for water. If any water is found, carefully check the boot for damage, input shaft dust seal, adjusting screw and boot clips for poor sealing. If faulty, replace with new parts.

No.	Parts	Inspection	Corrective action
1	Input shaft	(1) Bend of input shaft (2) Damage on serration	If the bend or damage is excessive, replace the entire gearbox.
2	Dust seal	(1) Crack or damage (2) Wear	If the outer wall slips, the lip is worn out or damage is found, replace it with a new one.
3	Rack and pinion	Poor mating of rack with pinion	(1) Adjust the backlash properly. By measuring the turning torque of gearbox and sliding resistance of rack, check if rack and pinion engage uniformly and smoothly with each other. (Refer to "Service limit".) (2) Keeping the rack pulled out all the way so that all teeth emerge, check teeth for damage. Even if abnormality is found in either (1) or (2), replace the entire gearbox.
4	Gearbox unit	(1) Bend of rack shaft (2) Bend of cylinder portion (3) Crack or damage on cast iron portion	Replace the gearbox with a new one.
		(4) Wear or damage on rack bushing	If the free play of rack shaft in radial direction is out of the specified range, replace the gearbox with a new one. (Refer to "Service limit".)
		(5) Wear on input shaft bearing	If the free plays of input shaft in radial and axial directions are out of the specified ranges, replace the gearbox with a new one. (Refer to "Service limit".)
5	Boot	Crack, damage or deterioration	Replace.
6	Tie-rod	(1) Looseness of ball joint (2) Bend of tie-rod	Replace.
7	Tie-rod end	Damage or deterioration on dust seal	Replace.
8	Adjusting screw spring	Deterioration	Replace.
9	Boot clip	Deterioration	Replace.
10	Sleeve	Damage	Replace.
11	Pipes	(1) Damage to flared surface (2) Damage to flare nut (3) Damage to pipe	Replace.

Steering Gearbox

POWER ASSISTED SYSTEM (POWER STEERING)

2. SERVICE LIMIT

Make a measurement as follows. If it exceeds the specified service limit, adjust or replace.

NOTE:

When making a measurement, vise the gearbox by using ST. Never vise the gearbox by inserting aluminum plates, etc. between vise and gearbox.

ST 926200000 STAND

Sliding resistance of rack shaft:

Service limit

400 N (41 kgf, 90 lbf) or less

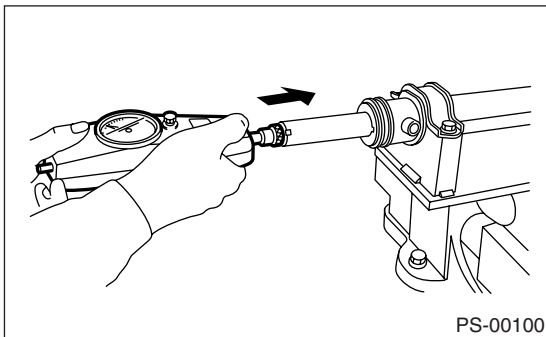
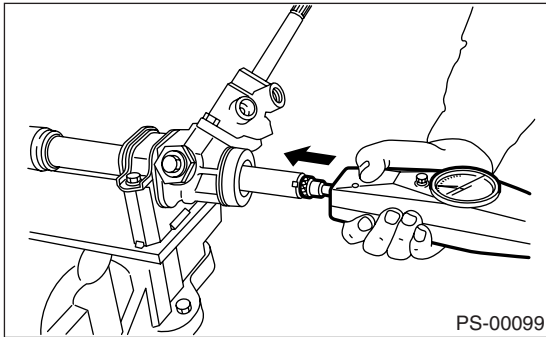

3. RACK SHAFT PLAY IN RADIAL DIRECTION

Right-turn steering:

Service limit

0.19 mm (0.0075 in) or less

On condition

L: 5 mm (0.20 in)

P: 122.6 N (12.5 kgf, 27.6 lbf)

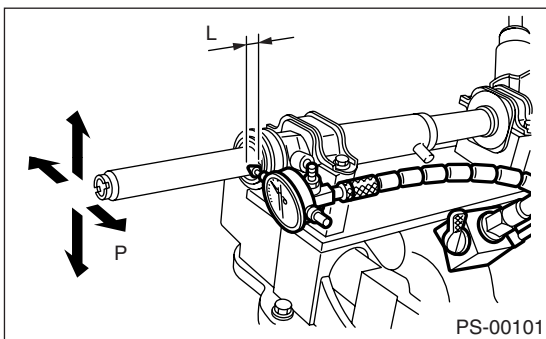

Left-turn steering:

Service limit

Direction ⇄

0.3 mm (0.012 in) or less

Direction ⇄

0.15 mm (0.0059 in) or less

L: 5 mm (0.20 in)

P: 98 N (10 kgf, 22 lbf)

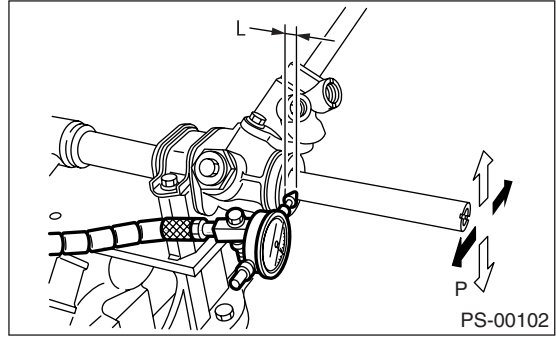

4. INPUT SHAFT PLAY

In radial direction:

Service limit

0.18 mm (0.0071 in) or less

On condition

P: 98 N (10 kgf, 22 lbf)

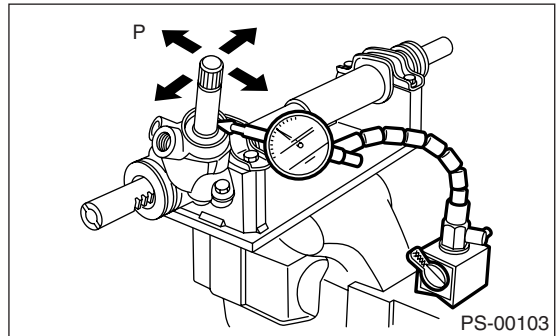

In axial direction:

Service limit

0.5 mm (0.020 in) or less

On condition

P: 20 — 49 N (2 — 5 kgf, 4 — 11 lbf)

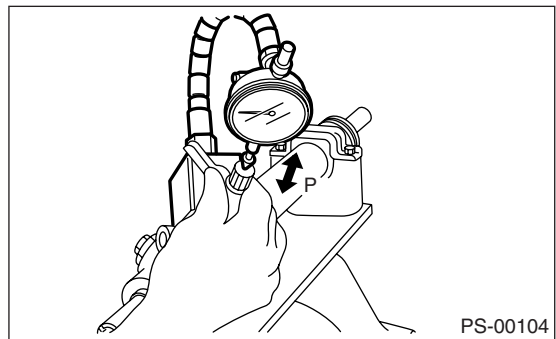

Steering Gearbox

POWER ASSISTED SYSTEM (POWER STEERING)

5. TURNING RESISTANCE OF GEARBOX

Using the ST, measure the gearbox turning resistance.

ST 34099PA100 SPANNER

Service limit

Maximum allowable resistance

10.5 N (1.1 kgf, 2.4 lbf) or less

Difference between right and left turning resistance: Less than 20%

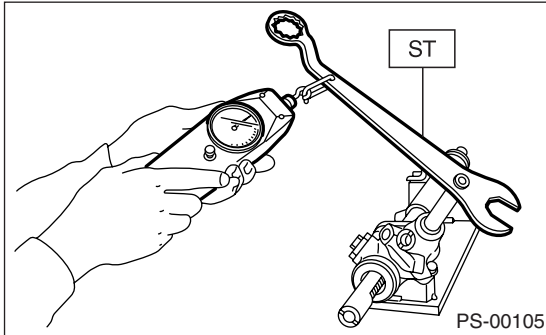

6. OIL LEAKING

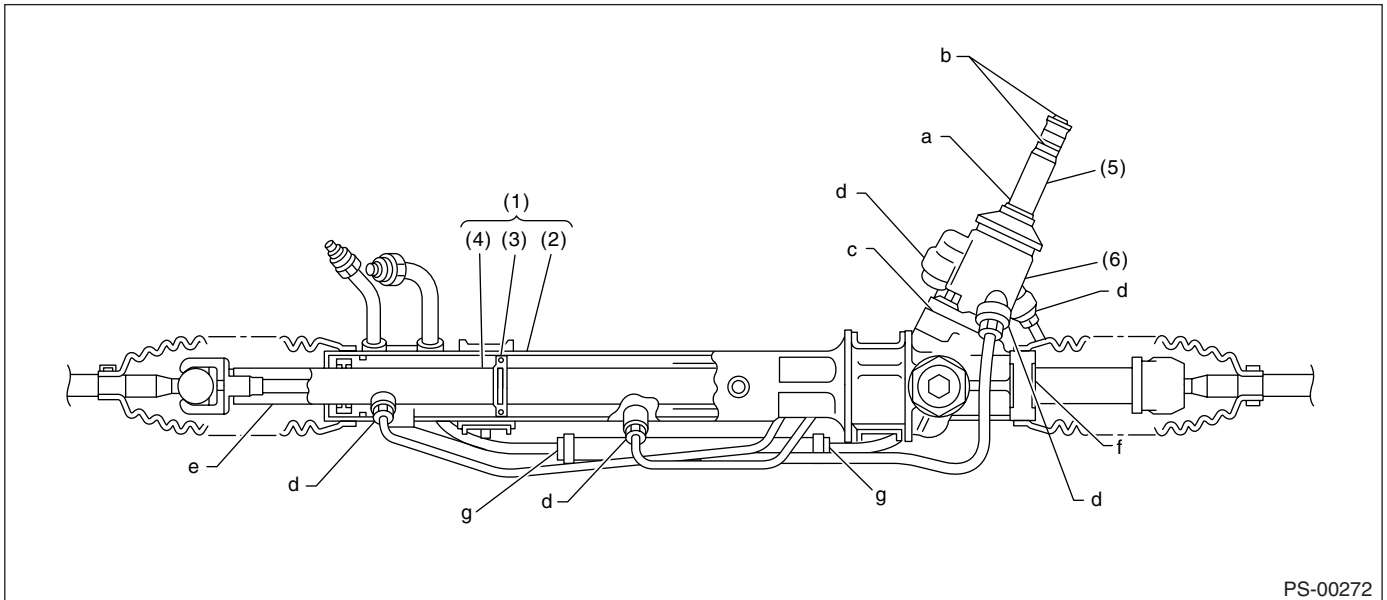

(1) Power cylinder

(3) Rack piston

(5) Input shaft

(2) Cylinder

(4) Rack axle

(6) Valve housing

1) Lift up the vehicle.

2) Even if the location of the leak can be easily found by observing the leaking condition, it is necessary to thoroughly remove the fluid from the suspected portion and turn the steering wheel from lock to lock about thirty to forty times with engine running, then make comparison of the suspected portion between immediately after and several hours after this operation.

3) Inspect leakage from "a".

The oil seal is damaged. Replace the valve assembly with a new one.

4) Inspect leakage from "b".

The torsion bar O-ring is damaged. Replace the valve assembly with a new one.

5) Inspect leakage from "c".

The oil seal is damaged. Replace the valve assembly or oil seal with a new one.

6) Inspect leakage from "d".

The pipe is damaged. Replace the faulty pipe or O-ring.

Steering Gearbox

POWER ASSISTED SYSTEM (POWER STEERING)

7) Inspect leakage from “g”.

The hose is damaged. Replace the hose with a new one.

8) If leak is other than a, b, c, d, or g, and if oil is leaking from the gearbox, move the right and left boots toward tie-rod end side, respectively, with the gearbox mounted to the vehicle, and remove fluid from the surrounding portions. Then, turn the steering wheel from lock to lock thirty to forty times with the engine running, then make comparison of the leaked portion immediately after and several hours after this operation.

(1) Leakage from “e”

The cylinder seal is damaged. Replace the rack bushing with a new one.

(2) Leakage from “f”

There are two possible causes. Take the following step first. Remove the pipe assembly B from the valve housing, and close the circuit with ST.

ST 926420000 PLUG

Turn the steering wheel from lock to lock thirty to forty times with the engine running, then make comparison of the leaked portion between immediately after and several hours after this operation.

- If leakage from “f” is noted again:

The oil seal of pinion and valve assembly is damaged. Replace the pinion and valve assembly with a new one. Or replace the oil seal and parts that are damaged during disassembly with new ones.

- If oil stops leaking from “f”:

The oil seal of rack housing is damaged. Replace the oil seal and the parts that are damaged during disassembly with new ones.

F: ADJUSTMENT

1) Adjust the front toe. <Ref. to FS-10, FRONT WHEEL TOE-IN, INSPECTION, Wheel Alignment.>

Standard of front toe:

IN 3 — OUT 3 mm (IN 0.12 — OUT 0.12 in)

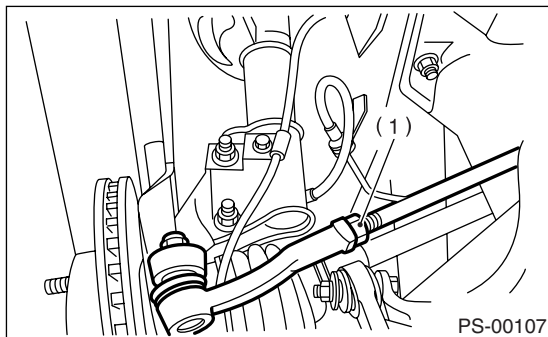

(1) Lock nut

2) Adjust the steering angle of wheels.

Standard of steering angle:

Model	2.5i, OUTBACK, WRX	STI
Inner wheel	34.5°±1.5°	32.9°±1.5°
Outer wheel	30.3°±1.5°	28.5°±1.5°

3) If the steering wheel spokes are not horizontal when wheels are set in the straight ahead position, and error is more than 5° on the periphery of steering wheel, correctly re-install the steering wheel.

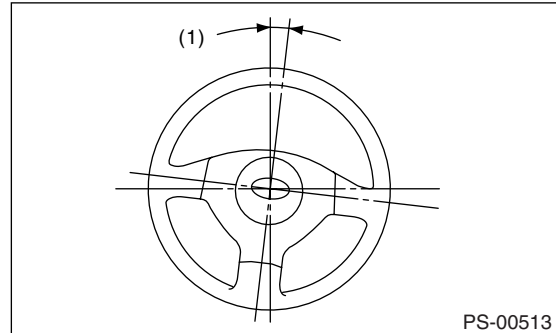

(1) Within 5°

4) If the steering wheel spokes are not horizontal with vehicle set in the straight ahead position after this adjustment, correct it by turning the right and left tie-rods in opposite direction by same angle.

Pipe Assembly

POWER ASSISTED SYSTEM (POWER STEERING)

6. Pipe Assembly

A: REMOVAL

- 1) Disconnect the ground cable from battery.
- 2) Lift-up the vehicle, and then remove the jack-up plate.

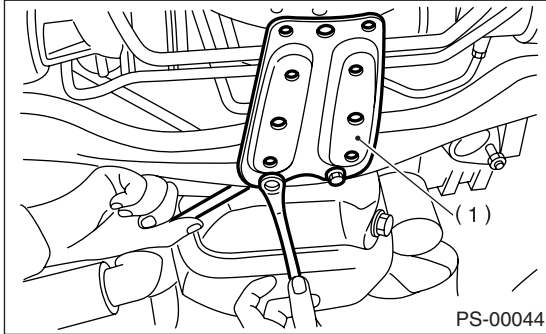

(1) Jack-up plate

- 3) Remove the one pipe joint at the center of gear-box, and then connect the vinyl hose to pipe and joint. Discharge fluid by turning steering wheel fully clockwise and counterclockwise. Discharge fluid similarly from the other pipe.

- Non-turbo model

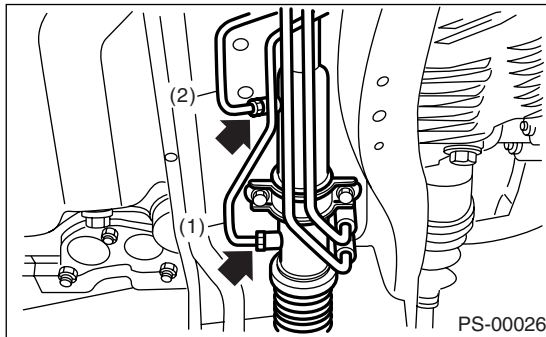

(1) Pipe A
(2) Pipe B

- Turbo model

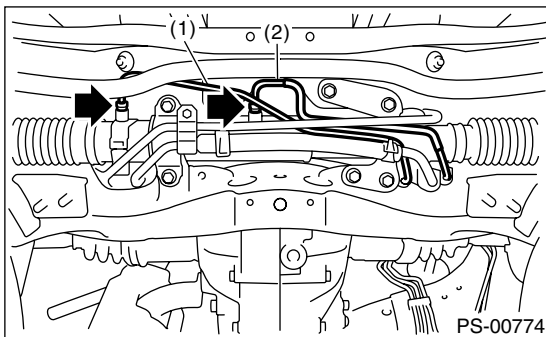

(1) Pipe A
(2) Pipe B

- 4) Remove the clamp E from pipes C and D.

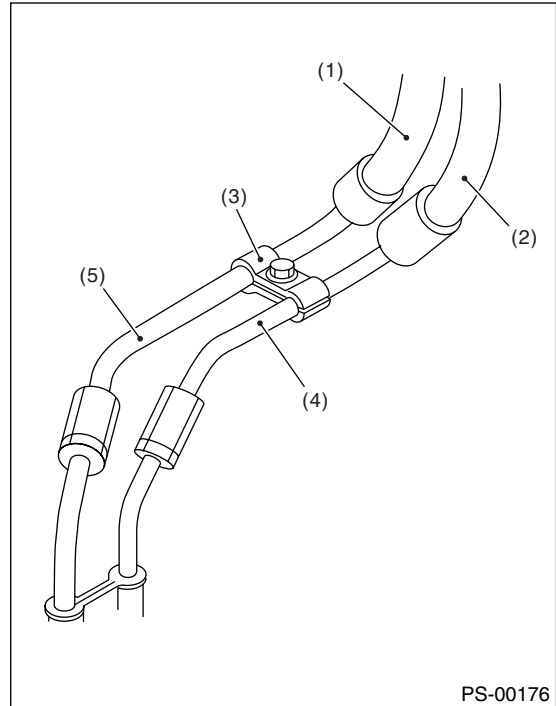

(1) Return hose
(2) Pressure hose
(3) Clamp E
(4) Pipe C
(5) Pipe D

- 5) Disconnect the pipe C and D from gear box.

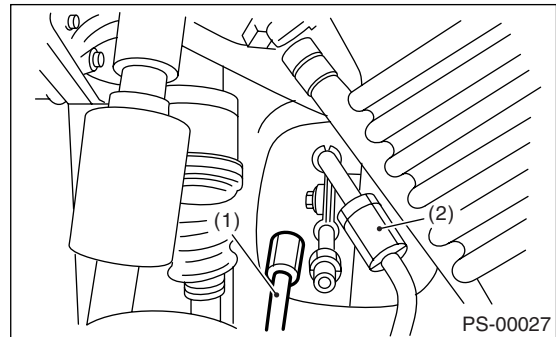

(1) Pipe C
(2) Pipe D

- 6) Non-turbo model

- (1) Remove the air intake duct. <Ref. to IN(H4SO)-7, REMOVAL, Air Intake Duct.>
- (2) Remove the bolt A.
- (3) Disconnect the pipe C from oil pump. Disconnect the pipe D from return hose.

Pipe Assembly

POWER ASSISTED SYSTEM (POWER STEERING)

CAUTION:

- Do not allow fluid from the hose end to come into contact with pulley belt.
- To prevent foreign matter from entering the hose and pipe, cover the open ends of them with a clean cloth.

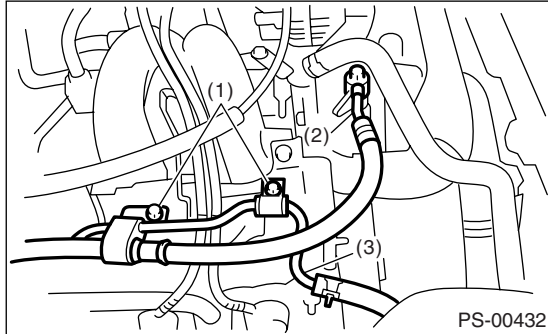

- (1) Bolt A
- (2) Pipe C
- (3) Pipe D

CAUTION:

- Do not allow fluid from the hose end to come into contact with pulley belt.
- To prevent foreign matter from entering the hose and pipe, cover the open ends of them with a clean cloth.

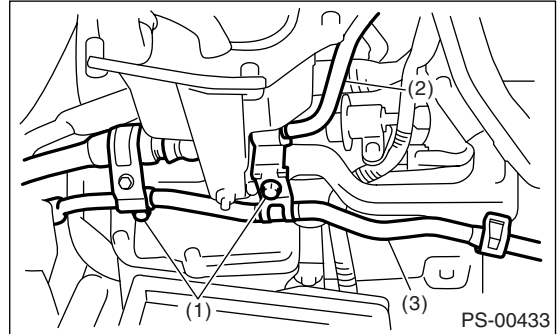

- (1) Bolt A
- (2) Pipe C
- (3) Pipe D

7) Turbo model

- (1) Remove the air cleaner.
<Ref. to IN(H4DOTC)-8, REMOVAL, Air Cleaner Case.>
- (2) Remove the coolant filler tank.

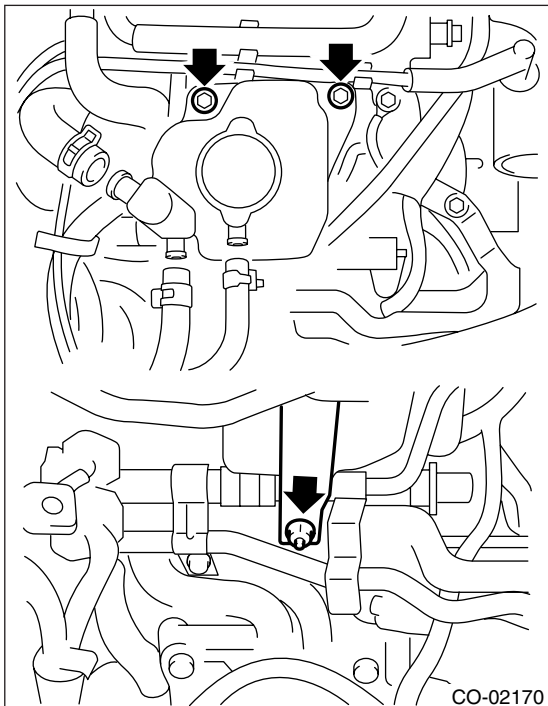

- (3) Remove the two bolts fixing pipe C and D. (bolt A)
- (4) Disconnect the pipe C from oil pump. Disconnect the pipe D from return hose.

B: INSTALLATION

- 1) Temporarily tighten the two bolts fixing pipe C and D. (bolt A)

NOTE:

Visually check that the hose between tank and pipe D is free from bending or twisting.

- Non-turbo model

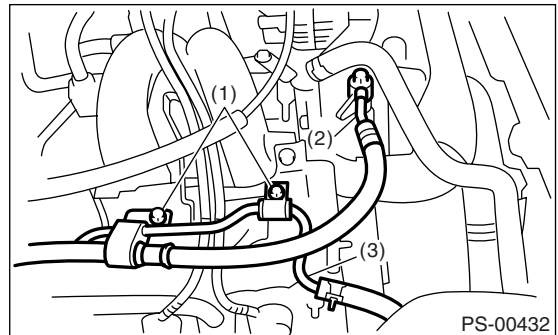

- (1) Bolt A
- (2) Pipe C
- (3) Pipe D

Pipe Assembly

POWER ASSISTED SYSTEM (POWER STEERING)

- Turbo model and STI model

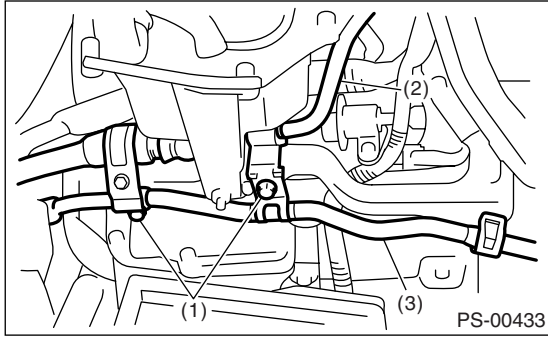

- (1) Bolt A
- (2) Pipe C
- (3) Pipe D

- (1) Connect the pipe D to oil tank.
- (2) Using a new gasket, connect the pipe C to oil pump.

Tightening torque:

40 N·m (4.1 kgf-m, 29.5 ft-lb)

- (3) Tighten the two bolts fixing pipe C and D. (bolt A)

Tightening torque:

13 N·m (1.3 kgf-m, 9.4 ft-lb)

- 2) Install the coolant filler tank. (Turbo model)

Tightening torque:

T1: 16 N·m (1.6 kgf-m, 11.8 ft-lb)

T2: 13 N·m (1.3 kgf-m, 9.4 ft-lb)

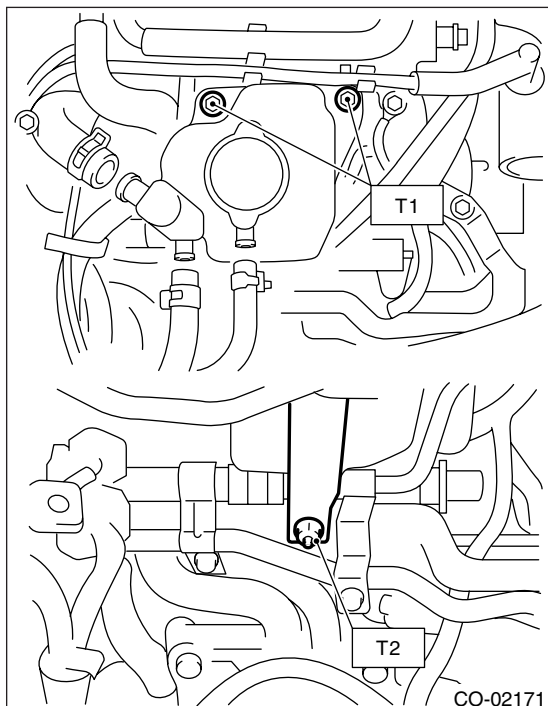

- 3) Temporarily connect the pipe C and D to gear box.

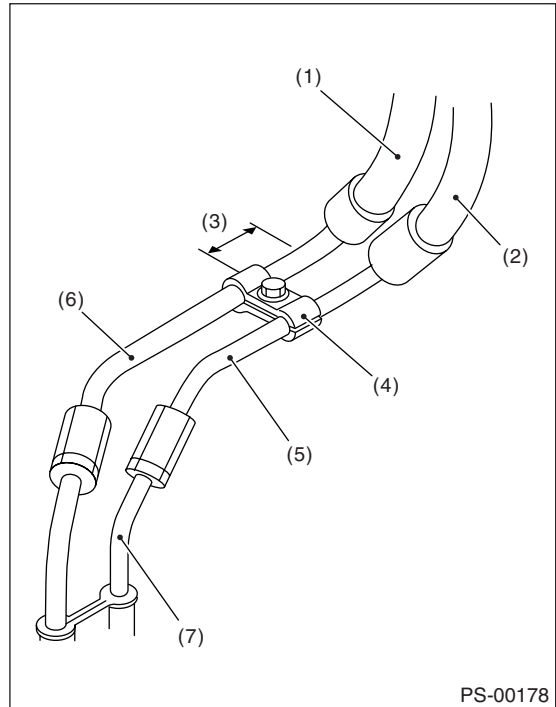

- (1) Return hose
- (2) Pressure hose
- (3) Approx. 30 mm (1.18 in)
- (4) Clamp E
- (5) Pipe C
- (6) Pipe D
- (7) Pipe (Gear box side)

- 4) Temporarily install the clamp E on pipes C and D.

NOTE:

Ensure the letter "8" on each clamp are diagonally opposite each other as shown in the figure.

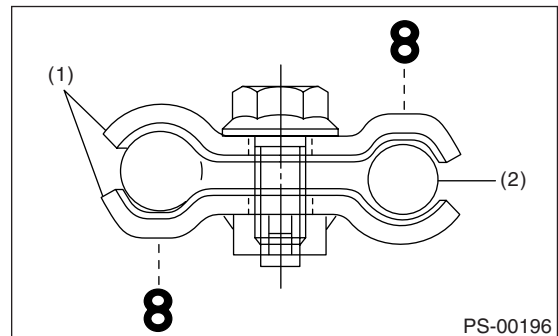

- (1) Clamp E
- (2) Pipe C

- 5) Tighten the clamp E firmly.

Tightening torque:

7.4 N·m (0.75 kgf-m, 5.4 ft-lb)

Pipe Assembly

POWER ASSISTED SYSTEM (POWER STEERING)

6) Tighten the joint nut.

Tightening torque:

15 N·m (1.5 kgf·m, 10.8 ft·lb)

7) Connect the pipes A and B to four pipe joints of gearbox. Connect the upper pipe B first, and lower pipe A second.

Tightening torque:

Non-turbo model:

13 N·m (1.3 kgf·m, 9.4 ft·lb)

Turbo model and STI model:

Housing side:

20 N·m (2.0 kgf·m, 14.5 ft·lb)

Cylinder side:

24 N·m (2.4 kgf·m, 17.4 ft·lb)

- Non-turbo model

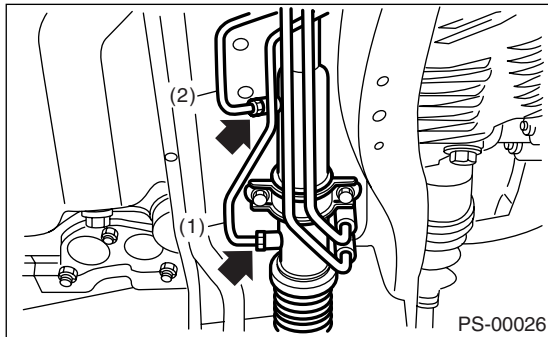

(1) Pipe A

(2) Pipe B

- Turbo model

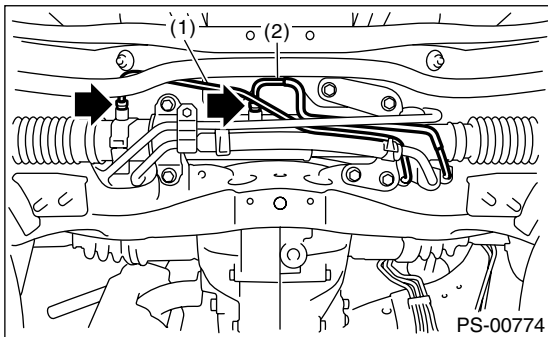

(1) Pipe A

(2) Pipe B

8) Install the jack-up plate.

9) Install the air intake duct. <Ref. to IN(H4SO)-7, INSTALLATION, Air Intake Duct.>

10) Install the air intake duct, air cleaner upper cover and air intake boot.

<Ref. to IN(H4DOTC)-8, INSTALLATION, Air Cleaner Case.> and <Ref. to IN(H4SO)-7, INSTALLATION, Air Intake Duct.>

11) Connect the battery ground cable to battery.

12) Feed the specified fluid.

CAUTION:

Never start the engine before feeding the fluid; otherwise vane pump might be seized up.

Pipe Assembly

POWER ASSISTED SYSTEM (POWER STEERING)

13) Finally check clearance between pipes and/or hoses, as shown above.

If cruise control actuator-to-power steering hose clearance is less than 10 mm (0.39 in), move the portion (A) secured by clamp to other portion, or bend portion (B) to adjust.

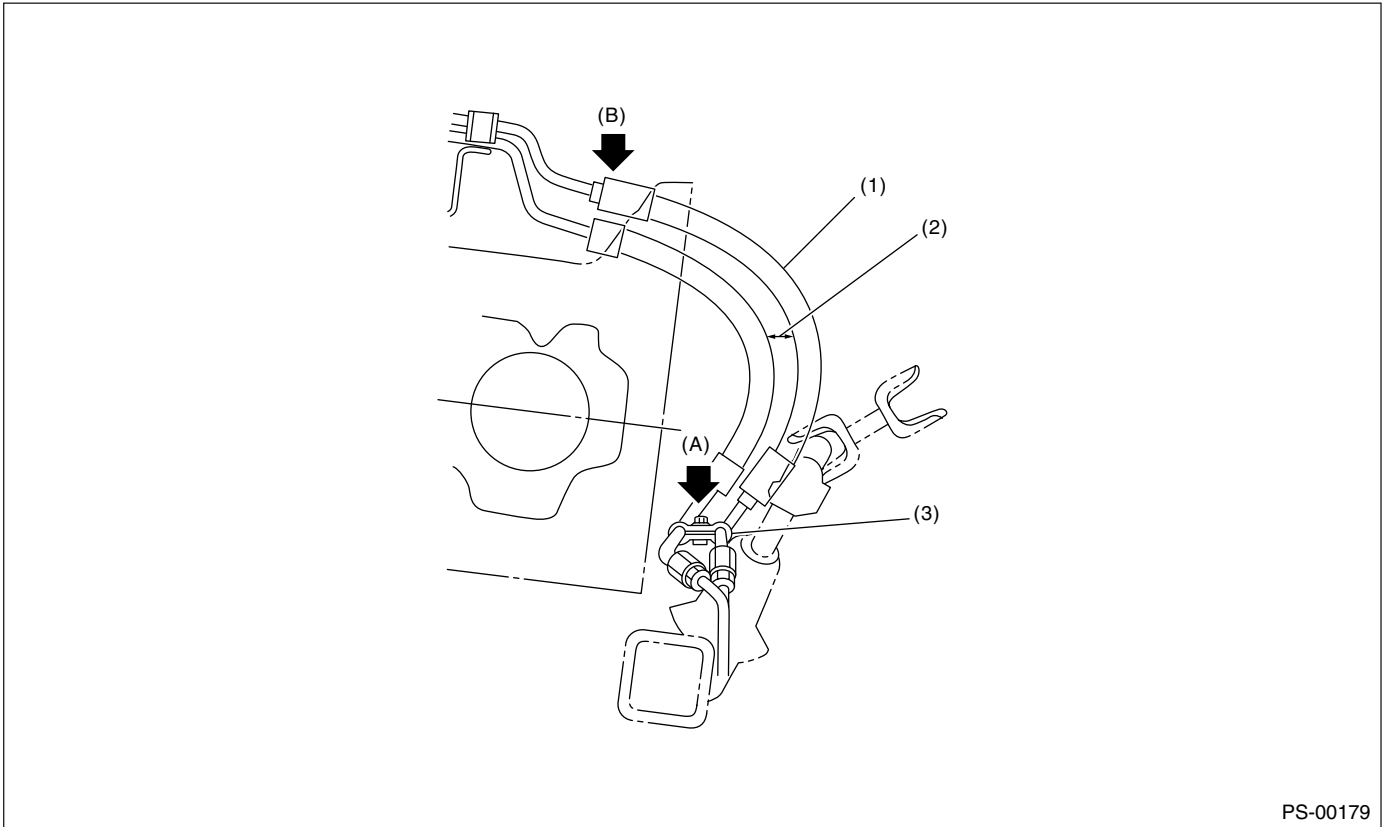

PS-00179

(1) High pressure hose

(2) No interference is allowed between hoses.

(3) Clearance between crossmember and pipe: 3 — 8 mm (0.12 — 0.31 in)

Pipe Assembly

POWER ASSISTED SYSTEM (POWER STEERING)

C: INSPECTION

Check all disassembled parts for wear, damage or other abnormalities. Repair or replace faulty parts as required.

Part name	Inspection	Remedy
Pipe	<ul style="list-style-type: none"> • O-ring fitting surface for damage • Nut for damage • Pipe for damage 	Replace with a new one.
Clamp	<ul style="list-style-type: none"> • Clamps for weak clamping force 	Replace with a new one.
Hose	<ul style="list-style-type: none"> • Flared surface for damage • Flare nut for damage • Outer surface for cracks • Outer surface for wear • Clip for damage • End coupling or adapter for degradation 	Replace with a new one.

CAUTION:

Although the surface layer materials of rubber hoses have excellent weathering resistance, heat resistance and resistance for low temperature brittleness, they are likely to be damaged chemically by brake fluid, battery electrolyte, engine oil and automatic transmission fluid and their service lives are to be very shortened. It is very important to keep the hoses free from before mentioned fluids and to wipe out immediately when the hoses are adhered with the fluids.

Since the resistances for heat or low temperature brittleness are gradually declining according to time accumulation of hot or cold conditions for the hoses and their service lives are shortening accordingly, it is necessary to perform the careful inspection frequently when the vehicle is used in hot weather areas, cold weather area and a driving condition in which many steering operations are required in short time.

Particularly, continuous work of relief valve over 5 seconds causes to reduce service lives of the hoses, the oil pump, the fluid, etc. due to over heat.

Trouble	Possible cause	Corrective action
Pressure hose burst	Excessive holding time of relief status	Instruct the customers.
	Malfunction of relief valve	Replace the oil pump.
	Poor cold characteristic of fluid	Replace the fluid.
Forced out return hose	Poor connection	Correct.
	Poor holding of clip	Retighten.
	Poor cold characteristic of fluid	Replace the fluid.
Fluid bleeding out of hose slightly	Wrong layout, tensioned	Replace the hose.
	Excessive play of engine due to deterioration of engine mounting rubber	Replace the defective parts.
	Improper stop position of pitching stopper	Replace the defective parts.
Crack on hose	Excessive holding time of relief status	Replace. Instruct customer.
	Excessive tightening torque for return hose clip	Replace.
	Power steering fluid, brake fluid, engine oil, electrolyte adhere on the hose surface	Replace. Pay attention on service work.
	Too many times use in extremely cold weather	Replace. Instruct the customers.

Pipe Assembly

POWER ASSISTED SYSTEM (POWER STEERING)

NOTE:

It is likely that although one judges fluid leakage, there is actually no leakage. This is because the fluid spilt during the last maintenance was not completely wiped off. Be sure to wipe off spilt fluid thoroughly after maintenance.

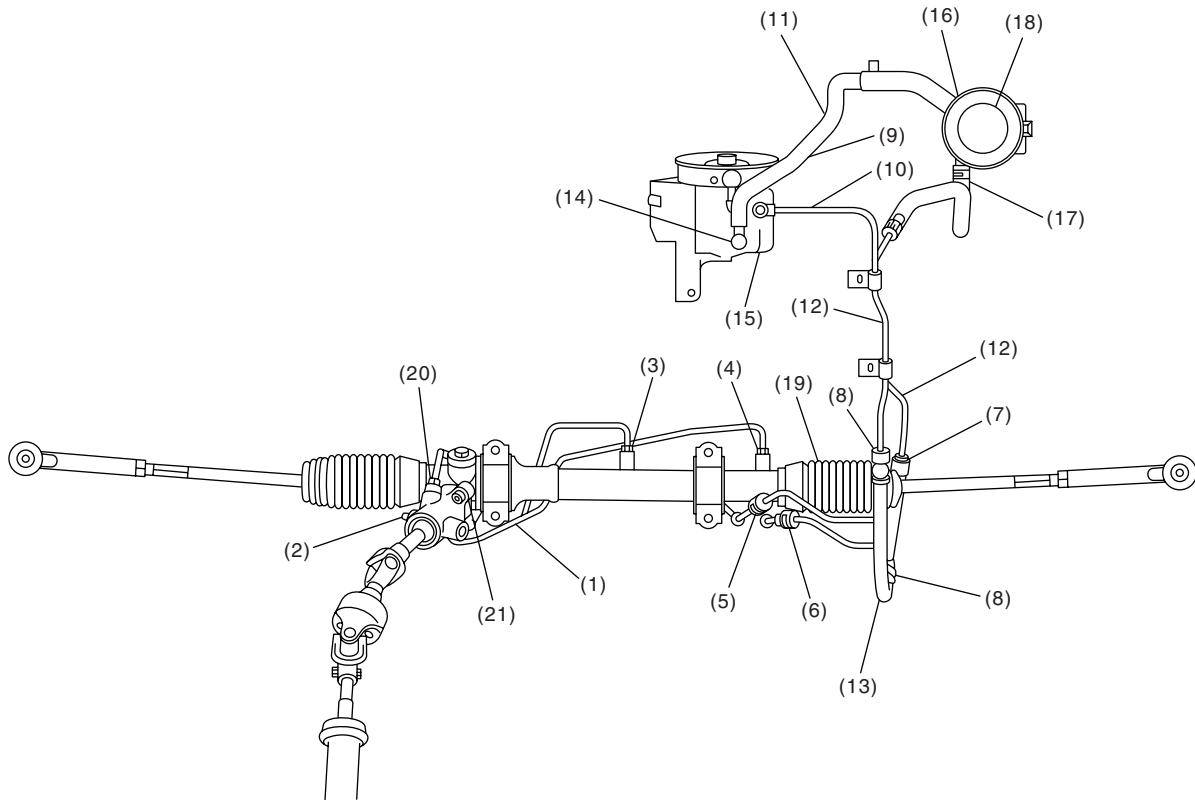

PS-00022

Pipe Assembly

POWER ASSISTED SYSTEM (POWER STEERING)

Fluid leaking area	Possible cause	Corrective action
Leakage from connecting portions of pipes and hoses, numbered with (1) through (10) in figure	Insufficient tightening of flare nut, catching dirt or the like, damage to flare or flare nut or eye bolt	Loosen and retighten, if ineffective, replace.
	Poor insertion of hose, poor clamping	Retighten or replace the clamp.
	Damaged O-ring or gasket	Replace the O-ring or gasket pipe or hose with new one, if ineffective, replace gearbox also.
Leakage from hose (11), (12) and (13) in figure	Crack or damage in hose	Replace with a new one.
	Crack or damage in hose hardware	Replace with a new one.
Leakage from surrounding of cast iron portion of oil pump (14) and (15) in figure	Damaged O-ring	Replace the oil pump.
	Damaged gasket	Replace the oil pump.
Leakage from oil tank (16) and (17) in figure	Crack in oil tank	Replace the oil tank.
Leakage from filler neck (18)	Damaged cap packing	Replace the cap.
	Crack in root of filler neck	Replace the oil tank.
	High fluid level	Adjust the fluid level.
Leakage from surrounding of power cylinder of gearbox (19) in figure	Damaged oil seal	Replace the oil seal.
Leakage from control valve of gearbox (20) and (21) in figure	Damaged packing or oil seal	Replace the problem parts.
	Damage in control valve	Replace the control valve.

Oil Pump

POWER ASSISTED SYSTEM (POWER STEERING)

7. Oil Pump

A: REMOVAL

- 1) Disconnect the ground cable from battery.
- 2) Remove the pulley belt cover.
- 3) Loosen the belt tension adjusting bolt and generator securing bolt, and then remove the power steering pump V-belt.

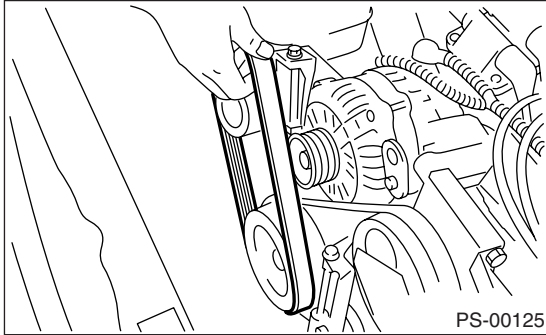

- 4) Disconnect the connector from power steering pump switch.
- 5) Disconnect the pipe C and suction hose from oil pump.

CAUTION:

- Do not allow fluid from the hose end to come into contact with pulley belt.
- To prevent foreign matter from entering the hose, cover the open ends of them with a clean cloth.

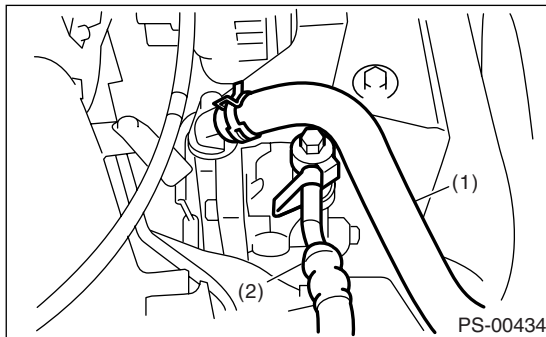

- (1) Suction hose
- (2) Pipe C

- 6) Remove the bolts which install the power steering pump bracket.

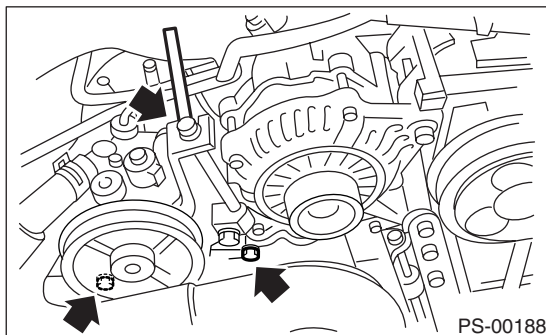

- 7) Place the oil pump bracket in a vise, remove the two bolts from front side of oil pump.

CAUTION:

Do not place the oil pump bracket directly in the vise; use soft pads and hold oil pump lightly to protect the pump.

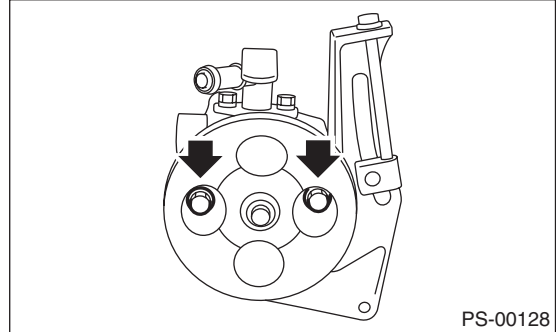

- 8) Remove the bolt from the rear side of oil pump.
- 9) Disassemble the oil pump and bracket by inserting a flat tip screwdriver as shown in the figure.

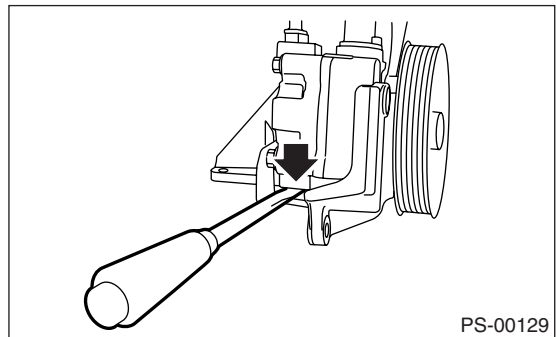

B: INSTALLATION

- 1) Install the oil pump to bracket.
 - (1) Place the oil pump bracket in a vise. Tighten the bushing using a 12.7 mm (1/2") type 14 mm and 21 mm box wrench until it is in contact with the oil pump mounting surface.

Oil Pump

POWER ASSISTED SYSTEM (POWER STEERING)

CAUTION:

Do not place the oil pump bracket directly in the vise; use soft pads and hold oil pump lightly to protect the pump.

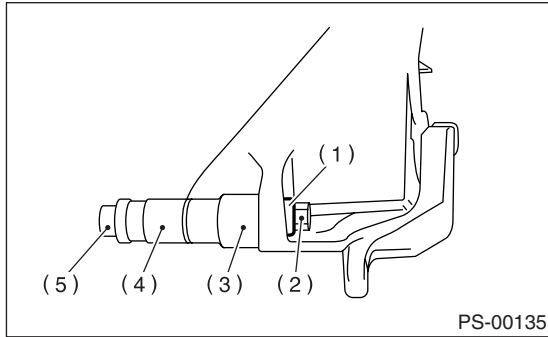

- (1) Bushing
- (2) Nut
- (3) 21 mm
- (4) 14 mm
- (5) Bolt

(2) Tighten the bolts which install the oil pump to bracket.

Tightening torque:

15.7 N·m (1.6 kgf-m, 11.6 ft-lb)

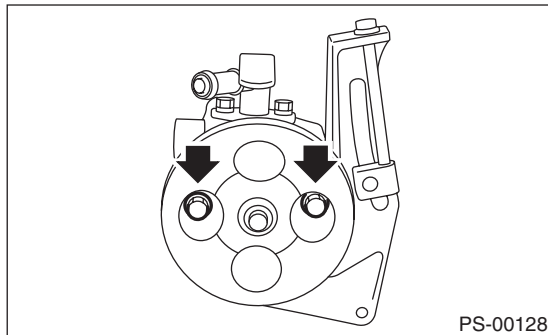

Tightening torque:

37.3 N·m (3.8 kgf-m, 27.5 ft-lb)

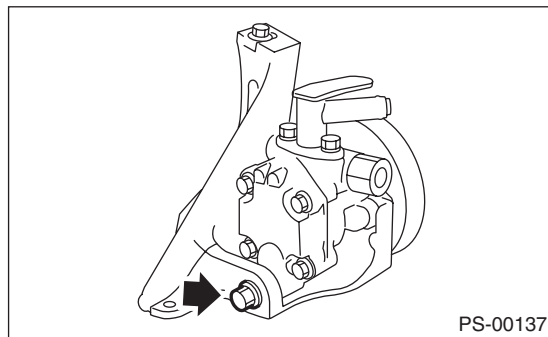

2) Tighten the bolts which install the power steering pump bracket.

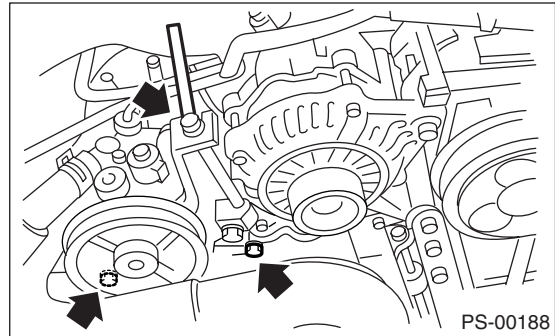

3) Interconnect the pipe C and suction hose.

Tightening torque:

Eye bolt

40 N·m (4.1 kgf-m, 29.5 ft-lb)

CAUTION:

If a hose is twisted at this step, the hose may come into contact with some other parts.

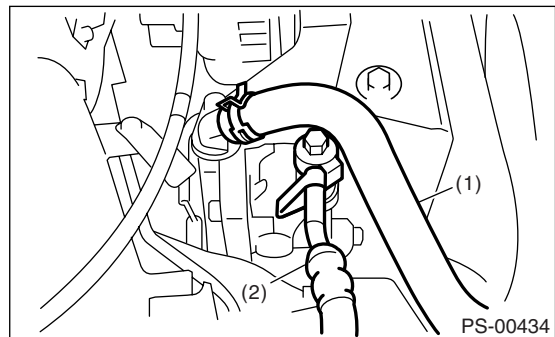

- (1) Suction hose
- (2) Pipe C

4) Connect the connector to power steering pump switch.

5) Install the pulley belt to oil pump.

6) Check the pulley belt tension.

<Ref. to ME(H4SO)-41, INSPECTION, V-belt.>

7) Tighten the bolt of belt tension.

Tightening torque:

25 N·m (2.5 kgf-m, 18.1 ft-lb)

8) Install the pulley belt cover.

9) Connect the battery ground cable to battery.

10) Feed the specified power steering fluid. <Ref. to PS-68, Power Steering Fluid.>

CAUTION:

Never start the engine before feeding the fluid; otherwise vane pump might be seized up.

Oil Pump

POWER ASSISTED SYSTEM (POWER STEERING)

C: INSPECTION

1. BASIC INSPECTION

Perform the following inspection procedures and repair or replace defective parts.

No.	Parts	Inspection	Corrective action
1	Oil pump (Exterior)	(1) Crack, damage or oil leakage	Replace the oil pump with a new one.
		(2) Play of pulley shaft	Measure the radial play and axial play. If any of these exceeds the service limit, replace the oil pump with a new one.
2	Pulley	(1) Damage	Replace it with a new one.
		(2) Bend	Measure the V ditch deflection. If it exceeds the service limit, replace the pulley with a new one.
3	Oil pump (Interior)	(1) Defect or burning of vane pump	Check the resistance to rotation of pulley. If it is past the service limit, replace the oil pump with a new one.
		(2) Bend in the shaft or damage to bearing	Oil pump emits a noise that is markedly different in tone and loudness from a sound of a new oil pump when turning with a string put around its pulley, replace the oil pump with a new one.
4	O-ring	Crack or deterioration	Replace it with a new one.
5	Bracket	Crack	Replace it with a new one.

2. SERVICE LIMIT

Make a measurement as follows. If it exceeds the specified service limit, replace the parts with new ones.

CAUTION:

- Fix the oil pump on a vise to make a measurement. At this time, hold the oil pump with least possible force between two wood pieces.
- Do not set outside of flow control valve or pulley on a vise; otherwise outside or pulley might be deformed. Select properly sized wood pieces.

1) Play of the pulley shaft

Condition:

P: When applying the force of 9.8 N (1.0 kgf, 2.2 lbf)

Service limit:

Radial play (Direction ← →)
0.4 mm (0.016 in) or less

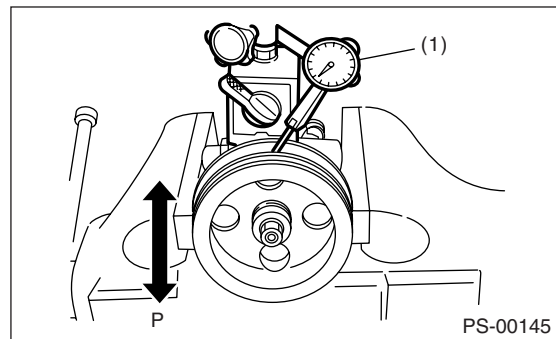

(1) Dial gauge

Axial play (Direction ⇐ ⇒)
0.9 mm (0.035 in) or less

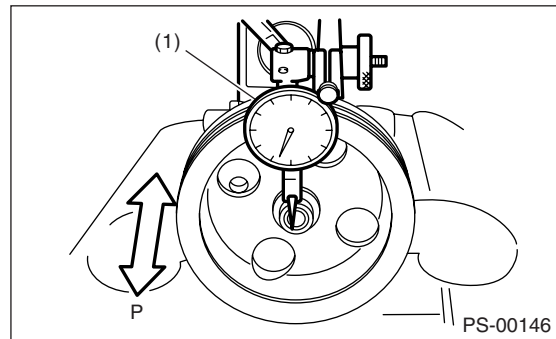

(1) Dial gauge

2) Ditch deflection of pulley

Oil Pump

POWER ASSISTED SYSTEM (POWER STEERING)

Service limit:

1.0 mm (0.039 in) or less

NOTE:

Read the value for one surface of V ditch, and then the value for another off the dial.

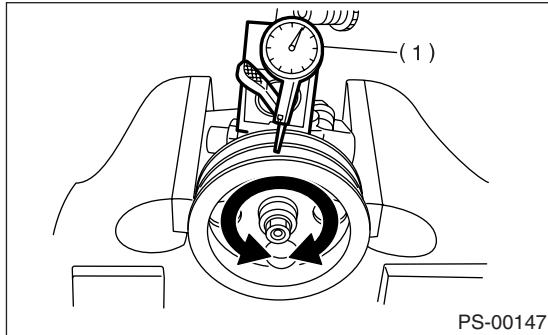

(1) Dial gauge

3) Resistance to rotation of pulley

Service limit:

Maximum load: 9.22 N (0.94 kgf, 2.07 lbf) or less

NOTE:

- A rather higher value may be indicated when pulley starts turning.
- Measure the load during rotation and make a judgment.

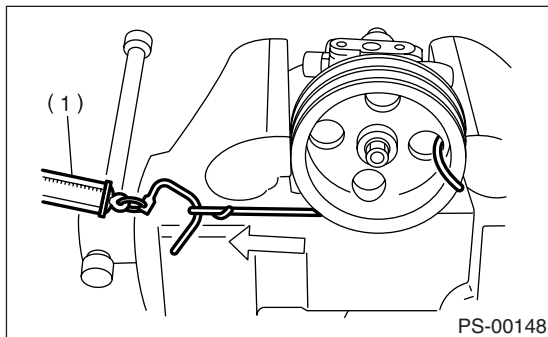

(1) Spring balance

3. HYDRAULIC PRESSURE

NOTE:

- Be sure to complete all items aforementioned in "INSPECTION", prior to measuring hydraulic pressure. Otherwise, pressure can not be measured correctly. <Ref. to PS-69, INSPECTION, General Diagnostic Table.>
- Do not leave the valve of pressure gauge closed or hold the steering wheel at stop end for 5 seconds or more in any case, as the oil pump may be damaged due to long keep of these conditions.
- Put a cotton cloth waste at a place where fluid drops before the pressure gauge is installed. Wipe off split fluid thoroughly after the measurement.

1) REGULAR PRESSURE MEASUREMENT

(1) Connect the ST1, ST2 and ST3.

ST1 925711000 PRESSURE GAUGE

ST2 34099AC020 ADAPTER HOSE B

ST3 34099AC010 ADAPTER HOSE A

(2) Remove the air intake duct.

(3) Disconnect the pipe C from the pump.

(4) Using the gasket (Part No. 34621AC022) and bolt (Part No. 34620AC010), install the ST2 to the pump instead of pipe C.

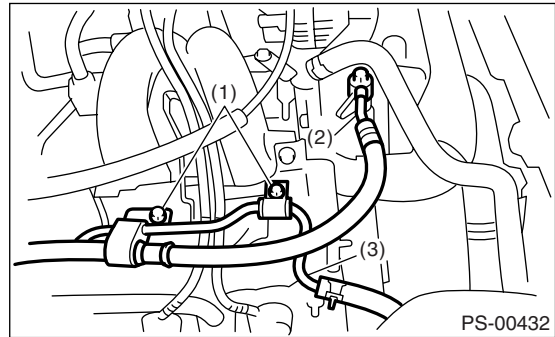

(1) Bolt A

(2) Pipe C

(3) Pipe D

(5) Install the ST3 to end of pipe C removed from pump.

(6) Replenish power steering fluid up to the specified level.

(7) Open the valve, and start the engine.

(8) Measure the regular pressure.

ST1 925711000 PRESSURE GAUGE

ST2 34099AC020 ADAPTER HOSE B

ST3 34099AC010 ADAPTER HOSE A

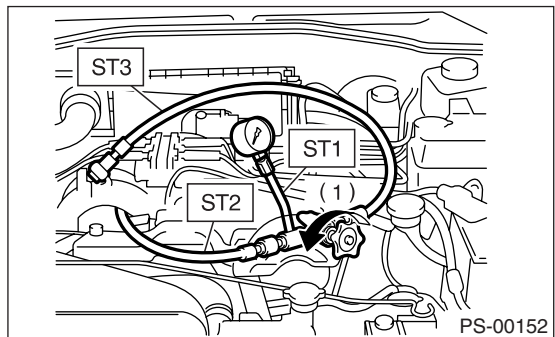

(1) Valve

Service limit:

981 kPa (10 kgf/cm², 142 psi) or less

(9) If it is not within the specified value, replace the troubled part caused by the following symptoms; pipe or hose clogged, leaks from fluid line, and mix of foreign objects in fluid line.

2) Measure the relief pressure.

(1) Using the STs, measure the relief pressure.

Oil Pump

POWER ASSISTED SYSTEM (POWER STEERING)

- (2) Close the valve.
- (3) Measure the relief pressure.

ST1 925711000 PRESSURE GAUGE
ST2 34099AC020 ADAPTER HOSE B
ST3 34099AC010 ADAPTER HOSE A

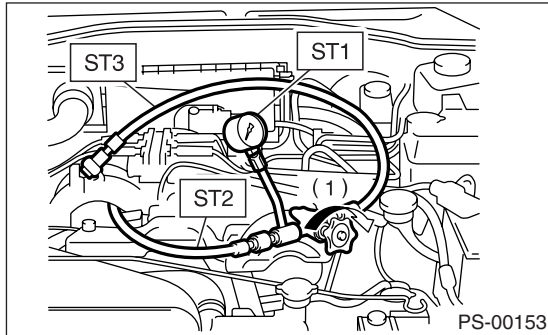

(1) Valve

Service limit:

Non-turbo model:

6,700 — 7,400 kPa (68 — 75 kgf/cm², 972 — 1,073 psi)

Turbo model and STI model:

7,350 — 8,036 kPa (75 — 82 kgf/cm², 1,067 — 1,165 psi)

- (4) If it is within the specified value, measure the steering effort. <Ref. to PS-72, MEASUREMENT OF STEERING EFFORT, INSPECTION, General Diagnostic Table.> If it is not within specified value, replace the control valve itself or control valve and pinion as a single unit with new ones.

Service limit:

Non-turbo model:

6,700 — 7,400 kPa (68 — 75 kgf/cm², 972 — 1,073 psi)

Turbo model and STI model:

7,350 — 8,036 kPa (75 — 82 kgf/cm², 1,067 — 1,165 psi)

- (4) If it is not within the specified value, replace the oil pump.
- 3) Measure the working pressure.
 - (1) Using the STs, measure the working pressure.
 - (2) Open the valve.
 - (3) Measure the working pressure of control valve by turning wheel from stop to stop.

ST1 925711000 PRESSURE GAUGE
ST2 34099AC020 ADAPTER HOSE B
ST3 34099AC010 ADAPTER HOSE A

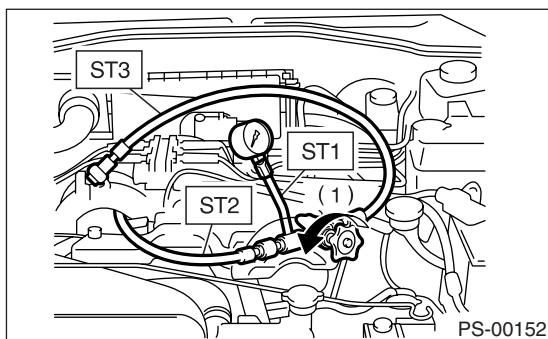

(1) Valve

Reservoir Tank

POWER ASSISTED SYSTEM (POWER STEERING)

8. Reservoir Tank

A: REMOVAL

- 1) Remove the air intake duct. <Ref. to IN(H4SO)-7, REMOVAL, Air Intake Duct.>
- 2) Drain fluid from the reservoir tank.
- 3) Disconnect the pipe D from return hose and suction hose from oil pump.

CAUTION:

- Do not allow fluid from the hose end to come into contact with pulley belt.
- To prevent foreign matter from entering the hose and pipe, cover the open ends of them with a clean cloth.

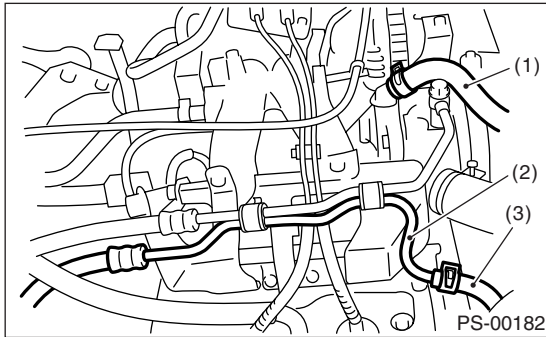

- (1) Suction hose
- (2) Pipe D
- (3) Return hose

- 4) Remove the reservoir tank from bracket by pulling it upwards.

B: INSTALLATION

- 1) Install the reservoir tank to bracket.
- 2) Connect the pipes D to return hose and suction hose to oil pump.

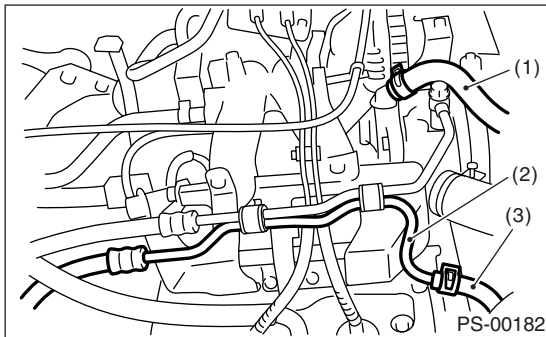

- (1) Suction hose
- (2) Pipe D
- (3) Return hose

- 3) Feed the power steering fluid to the specified level. <Ref. to PS-68, Power Steering Fluid.>

Power Steering Fluid

POWER ASSISTED SYSTEM (POWER STEERING)

9. Power Steering Fluid

A: SPECIFICATION

Recommended power steering fluid	Manufacturer
ATF DEXRON III or equivalent	B.P.
	CALTEX
	CASTROL
	MOBIL
	SHELL
	TEXACO

B: INSPECTION

- 1) Check the power steering fluid for deterioration or contamination. If the fluid is highly deteriorated or contaminated, drain it and refill with new fluid.
- 2) Check the joints and units for oil leakage. If any oil leaks are found, repair or replace the applicable part.
- 3) Inspect the fluid level on flat and level surface with engine "OFF" by indicator of reservoir tank. If the level is at MIN. point or below, add fluid to keep the level in the specified range of the indicator. If at MAX. point or above, drain fluid by using a syringe or the like.

(1) Check at power steering fluid temperature 20°C (68°F); read the fluid level on the "COLD" side.

(2) Check at power steering fluid temperature 80°C (176°F); read the fluid level on the "HOT" side.

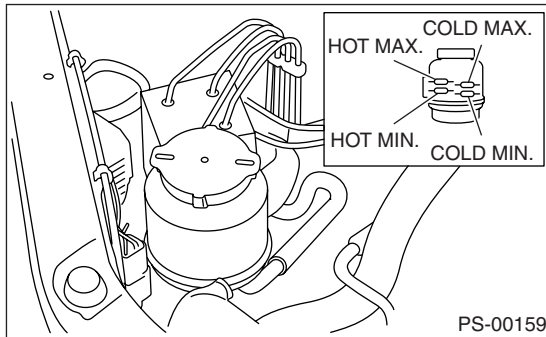

C: REPLACEMENT

- 1) Lift up the vehicle.
- 2) Remove the jack up plate.
- 3) Remove the pipe joint in center of gear box, and then install the vinyl hose to pipe and joint. Drain the fluid while turning steering wheel.
- 4) Set the ST on top of reservoir tank and fill it about half way with the specified fluid.

ST 34199AE040 OIL CHARGE GUIDE

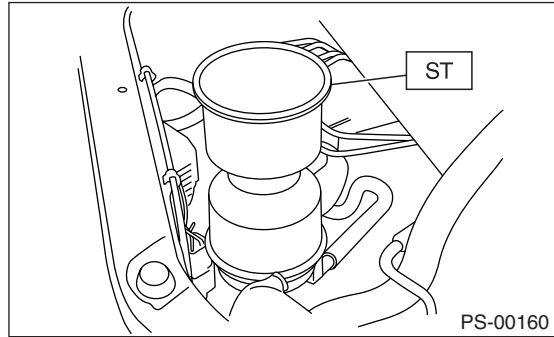

- 5) Continue to turn the steering wheel slowly from lock to lock until bubbles stop appearing on oil surface while keeping the fluid at that level.
- 6) If turning the steering wheel in low fluid level condition, air will be sucked in pipe. In this case, leave it about half an hour and then do the step 5) again.
- 7) Lift up the vehicle, start the engine and let it idle.
- 8) Continue to turn the steering wheel slowly from lock to lock again until bubbles stop appearing on oil surface while keeping the fluid at that level. It is normal that bubbles stop appearing after three times turning of steering wheel from lock to lock.
- 9) In case the bubbles do not stop appearing in the tank, leave it about half an hour and then do the step 4) all over again.
- 10) Lower the vehicle, and then idle the engine.
- 11) Continue to turn the steering wheel from lock to lock until bubbles stop appearing and change of the fluid level is within 3 mm (0.12 in).
- 12) In case the following happens, leave it about half an hour and then do step 8) to 11) again.
 - (1) The fluid level changes over 3 mm (0.12 in).
 - (2) Bubbles remain on the upper surface of the fluid.
 - (3) Grinding noise is generated from oil pump.
- 13) Check the fluid leakage after turning steering wheel from lock to lock with engine running.

General Diagnostic Table

POWER ASSISTED SYSTEM (POWER STEERING)

10. General Diagnostic Table

A: INSPECTION

Trouble	Possible cause	Corrective action
<ul style="list-style-type: none"> • Heavy steering effort in all ranges • Heavy steering effort at stand still • Steering wheel surges when turning. 	1. Pulley belt <ul style="list-style-type: none"> • Unequal length of pulley belts • Adhesion of oil and grease • Loose or damage of pulley belt • Poor uniformity of pulley belt cross section • Pulley belt touches to pulley bottom • Poor revolution of pulleys (except oil pump pulley) • Poor revolution of oil pump pulley 	Adjust or replace.
	2. Tire and wheel <ul style="list-style-type: none"> • Improper tires out of specification • Improper wheels out of specification • Tires not properly inflated *1 	Replace or reinflate.
	3. Fluid <ul style="list-style-type: none"> • Low fluid level • Aeration • Dust mix • Deterioration of fluid • Poor warming-up of fluid *2 	Refill, bleed air, replace or instruct the customer.
	4. Idle speed <ul style="list-style-type: none"> • Lower idle speed • Excessive drop of idle speed at start or at turning steering wheel *3 	Adjust or instruct the customer.
	5. Measure hydraulic pressure. <Ref. to PS-64, INSPECTION, Oil Pump.>	Replace the problem parts.
	6. Measure steering effort. <Ref. to PS-69, INSPECTION, General Diagnostic Table.>	Adjust or replace.
<ul style="list-style-type: none"> • Vehicle leads to one side or the other. • Poor return of steering wheel to center • Steering wheel surges when turning. 	1. Fluid line <ul style="list-style-type: none"> • Folded hose • Flattened pipe 	Reform or replace.
	2. Tire and wheel <ul style="list-style-type: none"> • Flat tire • Mix use of different tires • Mix use of different wheels • Abnormal wear of tire • Unbalance of remained grooves • Unbalance of tire pressure 	Adjust, fix or replace.
	3. Front alignment <ul style="list-style-type: none"> • Improper or unbalance caster • Improper or unbalance toe-in • Loose connection of suspension 	Adjust or retighten.
	4. Others <ul style="list-style-type: none"> • Damaged joint assembly • Unbalanced height • One-sided weight 	Replace, adjust or instruct the customer.
	5. Measure steering effort. <Ref. to PS-69, INSPECTION, General Diagnostic Table.>	Adjust or replace.

*1 If tires and/or wheels are wider, the load to power steering system is the more. Accordingly, in a condition, for example before fluid warms-up, relief valve may work before maximum turning angle. In this case, steering effort may be heavy. When measured hydraulic pressure is normal, there is no abnormal thing.

*2 In cold weather, steering effort may be heavy due to increased flow resistance of cold fluid. After warming-up engine, turn steering wheel from stop to stop several times to warm-up fluid. Then if steering effort reduces normally, there is no abnormal thing.

*3 In cold weather or with insufficient warm-up of engine, steering effort may be heavy due to excessive drop of idling when turning steering wheel. In this case, it is recommended to start the vehicle with increasing engine speed than usual. Then if steering effort reduces normally, there is no abnormal thing.

General Diagnostic Table

POWER ASSISTED SYSTEM (POWER STEERING)

1. NOISE AND VIBRATION

CAUTION:

Don't keep the relief valve operated over 5 seconds at any time or inner parts of the oil pump may be damaged due to rapid increase of fluid temperature.

NOTE:

- Grinding noise may be heard immediately after the engine start in extremely cold condition. In this case, if the noise goes off during warm-up there is no abnormal function in the system. This is due to the fluid characteristic in extremely cold condition.
- Oil pump makes whine or growl noise slightly due to its mechanism. Even if the noise can be heard when steering wheel is turned at stand still there is no abnormal function in the system provided that the noise eliminates when the vehicle is running.
- When turning the steering wheel with service brake and/or parking brake applied, the noise is generated by creaking between disk and pads. However this does not indicate abnormal function in system.
- There may be a little vibration around the steering devices when turning steering wheel at standstill, even though the component parts have no defects.

Hydraulic systems are likely to generate this kind of vibration as well as working noise and fluid noise because of combined conditions, i.e., road surface and tire surface, engine speed and turning speed of steering wheel, fluid temperature and braking condition.

This phenomena does not indicate there is some abnormal function in the system.

The vibration can be known when steering wheel is turned repeatedly at various speeds from slow to rapid step by step with parking brake applied on concrete road and in "D" range for AT model.

Trouble	Possible cause	Corrective action
Hiss noise (continuous) While engine is running.	Relief valve emits operating sound when steering wheel is completely turned in either direction. (Don't keep this condition over 5 seconds.)	Normal
	Relief valve emits operating sound when steering wheel is not turned. This means that the relief valve is faulty.	Replace the oil pump.
Rattling noise (intermittent) While engine is running.	Interference with adjacent parts	Check the clearance. Correct if necessary. <Ref. to PS-59, INSPECTION, Pipe Assembly.>
	Loosened installation of oil pump, oil tank, pump bracket, gearbox or crossmember	Retighten.
	Loosened installation of oil pump pulley or other pulley(s)	Retighten.
	Loosened linkage or play of steering or suspension Loosened tightening of joint or steering column	Retighten or replace.
	Sound generates from the inside of gearbox or oil pump.	Replace the faulty parts of gearbox or oil pump.
Knocking When turning steering wheel in both direction with small angle repeatedly at engine ON or OFF.	Excessive backlash Loosened lock nut for adjusting backlash	Adjust and retighten.
	Loosened tightening or play of tie-rod, or tie-rod end	Retighten or replace.
Grinding noise (continuous) While engine is running.	Vane pump aeration	Inspect and retighten the fluid line connection. Refill fluid and vent air.
	Vane pump seizing	Replace the oil pump.
	Pulley bearing seizing of oil pump	Replace the oil pump.
	Folded hose, flat pipe	Replace.
Squeal, squeak (intermittent or continuous) While engine is running.	Maladjustment of pulley belt Damaged or charged pulley belt Unequal length of pulley belts	Adjust or replace. (Replace two belts as a set.)
	Run out or soilage of V-groove surface of oil pump pulley	Clean or replace.

General Diagnostic Table

POWER ASSISTED SYSTEM (POWER STEERING)

Trouble	Possible cause	Corrective action
Sizzling noise (continuous) While engine is running.	Fluid aeration	Fix the wrong part causing aeration. Replace the fluid and vent air.
	Damaged pipe of gearbox	Replace the pipe.
	Abnormal inside of hose or pipe Flat hose or pipe	Rectify or replace.
	Abnormal inside of oil tank	Replace.
	Removed oil tank cap	Install the cap.
Whistle (continuous) While engine is running.	Abnormal pipe of gearbox or abnormal inside of hose	Replace the faulty parts of gearbox or hose.
Whine or growl (continuous or intermittent) While engine is running with/ without steering turned.	Loosened installation of oil pump, oil pump bracket	Retighten.
	Abnormal inside of oil pump, hose	Replace the oil pump, hose, if the noise can be heard when running as well as stand still.
	Torque converter growl, air conditioner compression growl	Remove the power steering pulley belt and confirm.
Creaking noise (intermittent) While engine is running with steering turned.	Abnormal inside of gearbox	Replace the faulty parts of gearbox.
	Abnormal bearing for steering shaft	Apply grease or replace.
	Generates when turning steering wheel with brake (service or parking) applied.	If the noise goes off when brake is released, it is normal.
Vibration While engine is running with/ without steering turned.	Too low engine speed	Adjust and instruct customers.
	Vane pump aeration	Fix the wrong part. Vent air.
	Damaged valve in oil pump, gearbox	Replace the oil pump, faulty parts of gearbox.
	Looseness of play of steering, suspension parts	Retighten.

General Diagnostic Table

POWER ASSISTED SYSTEM (POWER STEERING)

2. MEASUREMENT OF STEERING EFFORT

Step	Check	Yes	No
1 CHECK STEERING EFFORT. 1) Stop the vehicle on a concrete road. 2) Start the engine. 3) Idle the engine. 4) Install the spring scale on the steering wheel. 5) Pull the spring scale at an right angle to steering wheel, and measure both right and left steering wheel effort. NOTE: When turning the steering more quickly than necessary from a direction to the other direction at an engine speed over 2,000 rpm, steering effort may be heavy. This is caused by flow characteristic of oil pump and is not a problem.	Is the steering effort less than 31.4 N (3.2 kgf, 7.1 lbf)?	Go to step 2.	Adjust the backlash.
2 CHECK STEERING EFFORT. 1) Stop the engine. 2) Pull the spring scale at an right angle to the steering wheel, and measure both right and left steering wheel effort.	Is the steering effort less than 294.2 N (30 kgf, 66.2 lbf)?	Go to step 3.	Perform adjustment.
3 CHECK STEERING WHEEL EFFORT. 1) Remove the universal joint. 2) Measure the steering wheel effort.	Is the maximum steering effort less than 2.26 N (0.23 kgf, 0.51 lbf)?	Go to step 4.	Check, adjust and replace if necessary.
4 CHECK STEERING WHEEL EFFORT. Measure the steering wheel effort.	Is the difference of steering effort between clockwise and counterclockwise less than 20%?	Go to step 5.	Check, adjust and replace if necessary.
5 CHECK UNIVERSAL JOINT. Measure the swing torque of the joint (yoke of steering column side). <Ref. to PS-21, INSPECTION, Universal Joint.>	Is the swing torque less than 7.3 N (0.74 kgf, 1.64 lbf)?	Go to step 6.	Replace with new one.
6 CHECK UNIVERSAL JOINT. Measure the swing torque of the joint (yoke of gearbox side). <Ref. to PS-21, INSPECTION, Universal Joint.>	Is the swing torque less than 3.8 N (0.39 kgf, 0.86 lbf)?	Go to step 7.	Replace with new one.
7 CHECK FRONT WHEEL. Check the front wheel.	Are the front wheels for unsteady revolution or rattling and brake for dragging?	Inspect, readjust and replace if necessary.	Go to step 8.
8 CHECK TIE-ROD ENDS. Remove the tie-rod ends.	Are the tie-rod ends of suspension for unsteady revolution or rattling?	Inspect and replace if necessary.	Go to step 9.
9 CHECK BALL JOINT. Remove the ball joint.	Are the ball joints of suspension for unsteady revolution or rattling?	Inspect and replace if necessary.	Go to step 10.
10 CHECK GEARBOX. Measure the rotating of gearbox. <Ref. to PS-52, TURNING RESISTANCE OF GEARBOX, INSPECTION, Steering Gearbox.>	Is the rotating resistance of gear box less than 10.5 N (1.1 kgf, 2.4 lbf)? Is the difference between clockwise and counterclockwise 20%?	Go to step 11.	Readjust the backlash, and if ineffective, replace the faulty parts.
11 CHECK GEARBOX. Measure the sliding of gearbox. <Ref. to PS-51, SERVICE LIMIT, INSPECTION, Steering Gearbox.>	Is the sliding resistance of gear box less than 400 N (41 kgf, 90 lbf)? Is the difference between right and left 20%?	Steering effort is normal.	Readjust the backlash, and if ineffective, replace the faulty parts.

General Diagnostic Table

POWER ASSISTED SYSTEM (POWER STEERING)

3. CLEARANCE CHECK

This table lists various clearances that must be correctly adjusted to ensure the normal vehicle driving without interfering noise, or any other faults.

Location	Minimum allowance
(1) Crossmember — Pipe	5 mm (0.20 in)
(2) DOJ — Shaft or joint	14 mm (0.55 in)
(3) DOJ — Valve housing	11 mm (0.43 in)
(4) Pipe — Pipe	2 mm (0.08 in)
(5) Stabilizer — Pipe	5 mm (0.20 in)
(6) Exhaust pipe — Pipe	11 mm (0.43 in)
(7) Exhaust pipe — Gearbox bolt	15 mm (0.59 in)
(8) Side frame — Hose A and B	10 mm (0.39 in)
(9) Cruise control pump — Hose A and B	15 mm (0.59 in)
(10) Pipe portion of hose A — Pipe portion of hose B	1.5 mm (0.059 in)
(11) AT cooling hose — Joint	20 mm (0.79 in)

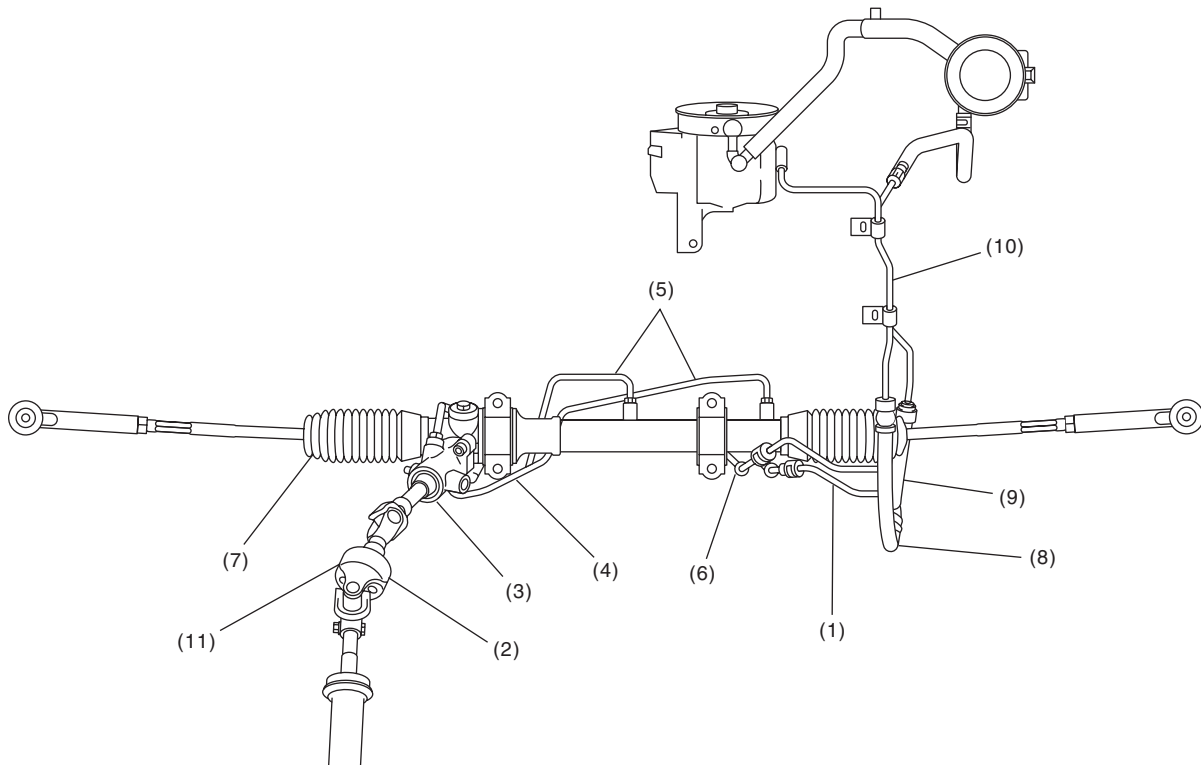

PS-00773

General Diagnostic Table

POWER ASSISTED SYSTEM (POWER STEERING)
