

DIFFERENTIALS

General Description

DIFFERENTIALS

1. General Description

A: SPECIFICATION

When replacing a rear differential assembly, select the correct one according to the following table.

NOTE:

Using the different rear differential assembly causes the drive line and tires to “drag” or emit noise when AWD is selected.

Model	2.5i, OUTBACK			WRX	
	AT	MT		AT	MT
Rear differential type	T-type model without LSD			T-type model with LSD	
LSD type	—			Viscous coupling	
Identification	EH	EG		P1	ER
Type of gear	Hypoid gear				
Gear ratio (Number of gear teeth)	4.111 (37/9)	3.900 (39/10)	4.111 (37/9)	3.900 (39/10)	3.700 (37/10)
Oil capacity	0.8 ℓ (0.8 US qt, 0.7 Imp qt)				
Rear differential gear oil	GL-5				

Model	STI
	6MT
Rear differential type	T-type model with LSD
LSD type	Mechanical
Identification	HX
Type of gear	Hypoid gear
Gear ratio (Number of gear teeth)	3.545 (39/11)
Oil capacity	1.0 ℓ (1.1 US qt, 0.9 Imp qt)
Rear differential gear oil	GL-5 (For mechanical LSD)

• **Identification**

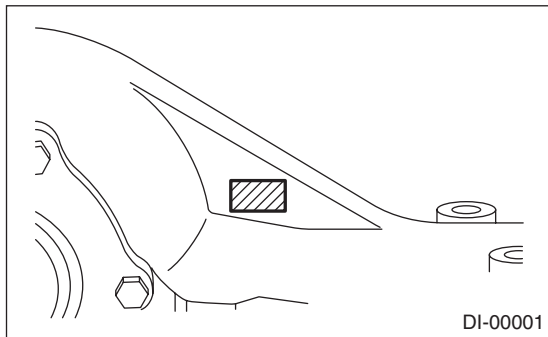

• **Rear differential gear oil**

Recommended oil

CAUTION:

Each oil manufacturer has its base oil and additives. Thus, do not mix two or more brands.

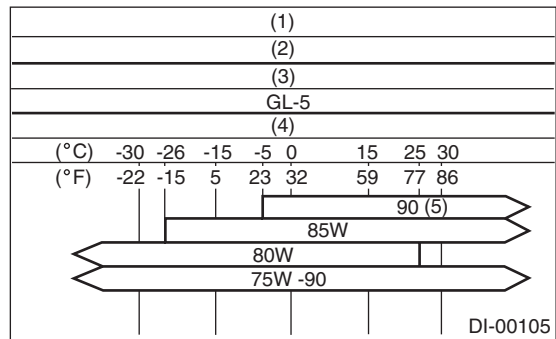

- (1) Item
- (2) Differential gear oil
- (3) API Standard
- (4) SAE viscosity No. and application temperature
- (5) STI model

General Description

DIFFERENTIALS

1. SERVICE DATA

Drive pinion bearing preload at companion flange bolt hole	N (kgf, lbf)	Except STI model	17.7 — 38.8 (1.8 — 4.0, 4.0 — 8.7)
		STI model	24.1 — 38.6 (2.5 — 3.9, 5.4 — 8.7)
Side gear backlash		mm (in)	0.10 — 0.20 (0.004 — 0.008)
Side bearing standard width		mm (in)	20.00 (0.7874)
Hypoid driven gear to drive pinion backlash		mm (in)	0.10 — 0.20 (0.004 — 0.008)
Hypoid driven gear runout on its back surface		mm (in)	Less than 0.05 (0.0020)

2. ADJUSTING PARTS

• Except STI model

Drive pinion bearing preload at companion flange bolt hole	N (kgf, lbf)	17.7 — 38.8 (1.8 — 4.0, 4.0 — 8.7)	
Preload adjusting spacer		Part No.	Length mm (in)
		383695201	56.2 (2.213)
		383695202	56.4 (2.220)
		383695203	56.6 (2.228)
		383695204	56.8 (2.236)
		383695205	57.0 (2.244)
		383695206	57.2 (2.252)
Preload adjusting washer		Part No.	Length mm (in)
		383705200	2.59 (0.1020)
		383715200	2.57 (0.1012)
		383725200	2.55 (0.1004)
		383735200	2.53 (0.0996)
		383745200	2.51 (0.0988)
		383755200	2.49 (0.0980)
		383765200	2.47 (0.0972)
		383775200	2.45 (0.0965)
		383785200	2.43 (0.0957)
		383795200	2.41 (0.0949)
		383805200	2.39 (0.0941)
		383815200	2.37 (0.0933)
		383825200	2.35 (0.0925)
	383835200	2.33 (0.0917)	
	383845200	2.31 (0.0909)	

General Description

DIFFERENTIALS

Pinion height adjusting washer	Part No.	Thickness mm (in)	
	383495200	3.09 (0.1217)	
	383505200	3.12 (0.1228)	
	383515200	3.15 (0.1240)	
	383525200	3.18 (0.1252)	
	383535200	3.21 (0.1264)	
	383545200	3.24 (0.1276)	
	383555200	3.27 (0.1287)	
	383565200	3.30 (0.1299)	
	383575200	3.33 (0.1311)	
	383585200	3.36 (0.1323)	
	383595200	3.39 (0.1335)	
	383605200	3.42 (0.1346)	
	383615200	3.45 (0.1358)	
	383625200	3.48 (0.1370)	
	383635200	3.51 (0.1382)	
	383645200	3.54 (0.1394)	
	383655200	3.57 (0.1406)	
	383665200	3.60 (0.1417)	
	383675200	3.63 (0.1429)	
383685200	3.66 (0.1441)		
Side gear backlash	mm (in)	0.1 — 0.2 (0.004 — 0.008)	
Side gear thrust washer (Model without LSD)	Part No.	Thickness mm (in)	
	383445201	0.75 — 0.80 (0.0295 — 0.0315)	
	383445202	0.80 — 0.85 (0.0315 — 0.0335)	
	383445203	0.85 — 0.90 (0.0335 — 0.0354)	
Side bearing standard width	mm (in)	— 20.00 (0.7874)	
Side bearing retainer shim	Part No.	Thickness mm (in)	
	383475201	0.20 (0.0079)	
	383475202	0.25 (0.0098)	
	383475203	0.30 (0.0118)	
	383475204	0.40 (0.0157)	
	383475205	0.50 (0.0197)	
Limit	Hypoid driven gear to drive pinion backlash	mm (in)	0.10 — 0.20 (0.004 — 0.008)
	Hypoid driven gear runout on its back surface	—	0.05 (0.0020)

• **STI model**

Drive pinion bearing preload at companion flange bolt hole	N (kgf, lbf)	24.1 — 38.6 (2.5 — 3.9, 5.4 — 8.7)
Preload adjusting spacer	Part No.	Length mm (in)
	31454AA130	52.2 (2.055)
	31454AA140	52.4 (2.063)
	31454AA150	52.6 (2.071)
	31454AA160	52.8 (2.079)
	31454AA170	53.0 (2.087)
	31454AA180	53.2 (2.094)

General Description

DIFFERENTIALS

Preload adjusting washer		Part No.	Length mm (in)
		383705200	2.59 (0.1020)
		383715200	2.57 (0.1012)
		383725200	2.55 (0.1004)
		383735200	2.53 (0.0996)
		383745200	2.51 (0.0988)
		383755200	2.49 (0.0980)
		383765200	2.47 (0.0972)
		383775200	2.45 (0.0965)
		383785200	2.43 (0.0957)
		383795200	2.41 (0.0949)
		383805200	2.39 (0.0941)
		383815200	2.37 (0.0933)
		383825200	2.35 (0.0925)
		383835200	2.33 (0.0917)
		383845200	2.31 (0.0909)
		Pinion height adjusting washer	
38336AA230	3.09 (0.1217)		
38336AA240	3.12 (0.1228)		
38336AA250	3.15 (0.1240)		
38336AA260	3.18 (0.1252)		
38336AA270	3.21 (0.1264)		
38336AA280	3.24 (0.1276)		
38336AA290	3.27 (0.1287)		
38336AA300	3.30 (0.1299)		
38336AA310	3.33 (0.1311)		
38336AA320	3.36 (0.1323)		
38336AA330	3.39 (0.1335)		
38336AA340	3.42 (0.1346)		
38336AA350	3.45 (0.1358)		
38336AA360	3.48 (0.1370)		
38336AA370	3.51 (0.1382)		
38336AA380	3.54 (0.1394)		
38336AA390	3.57 (0.1406)		
38336AA400	3.60 (0.1417)		
38336AA410	3.63 (0.1429)		
38336AA420	3.66 (0.1441)		
Side bearing standard width mm (in)		20.00 (0.7874)	
Side bearing retainer shim		Part No.	Thickness mm (in)
		383475201	0.20 (0.0079)
		383475202	0.25 (0.0098)
		383475203	0.30 (0.0118)
		383475204	0.40 (0.0157)
		383475205	0.50 (0.0197)
Limit mm (in)	Hypoid driven gear to drive pinion backlash	—	0.10 — 0.20 (0.004 — 0.008)
	Hypoid driven gear runout on its back surface		0.05 (0.0020)

General Description

DIFFERENTIALS

B: COMPONENT

1. REAR DIFFERENTIAL WITHOUT LSD

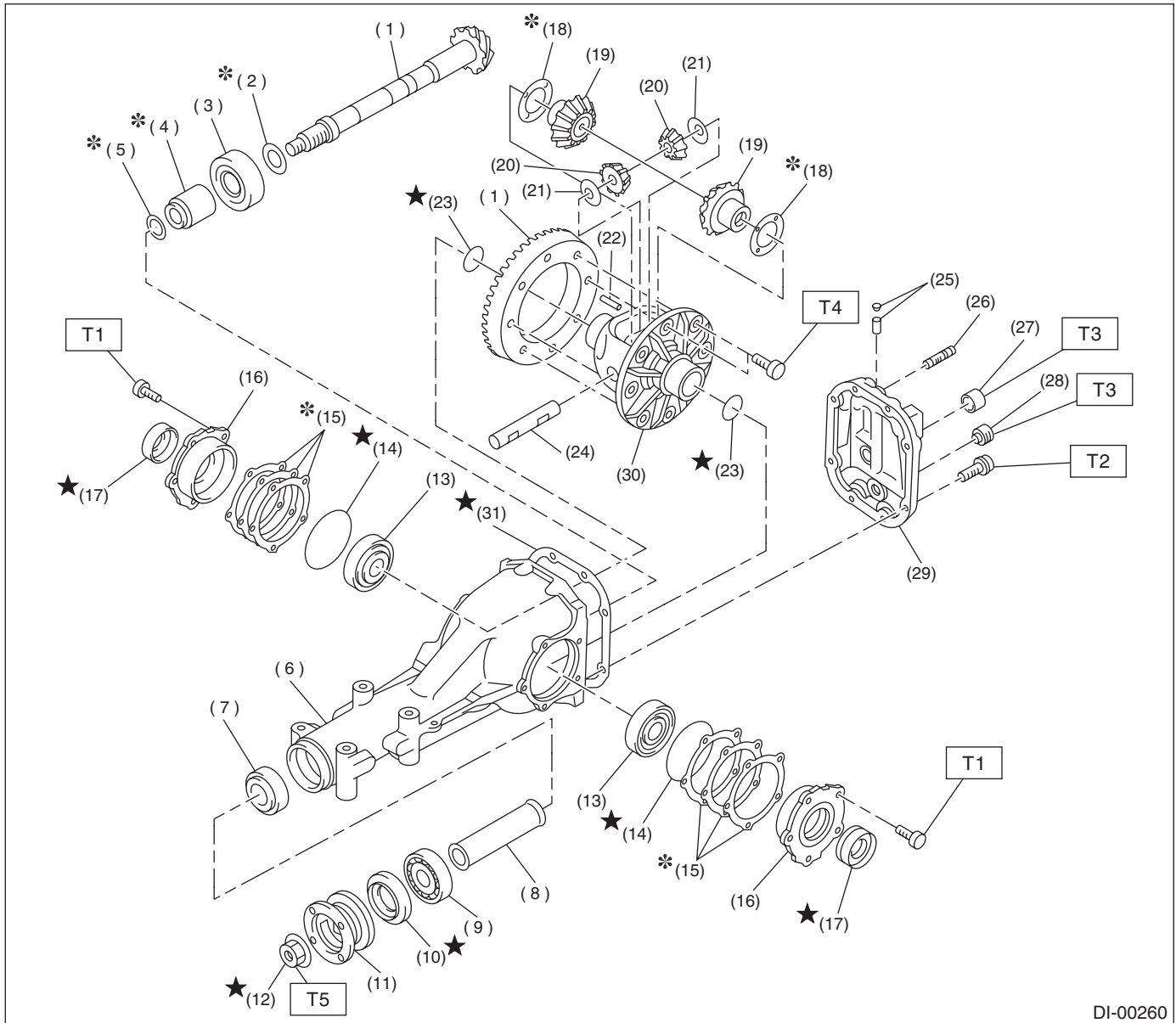

DI-00260

- | | | |
|--------------------------------------|---------------------------------|------------------------|
| (1) Driven gear and drive pinion set | (14) O-ring | (27) Oil filler plug |
| (2) Pinion height adjusting washer | (15) Side bearing retainer shim | (28) Oil drain plug |
| (3) Rear bearing | (16) Side bearing retainer | (29) Rear cover |
| (4) Bearing preload adjusting spacer | (17) Side oil seal | (30) Differential case |
| (5) Bearing preload adjusting washer | (18) Side gear thrust washer | (31) Gasket |
| (6) Differential carrier | (19) Side gear | |
| (7) Front bearing | (20) Pinion mate gear | |
| (8) Spacer | (21) Pinion mate gear washer | |
| (9) Pilot bearing | (22) Pinion shaft lock pin | |
| (10) Front oil seal | (23) Snap ring | |
| (11) Companion flange | (24) Pinion mate shaft | |
| (12) Self-locking nut | (25) Air breather cap | |
| (13) Side bearing | (26) Stud bolt | |

Tightening torque: N-m (kgf-m, ft-lb)

T1: 10.5 (1.1, 7.7)

T2: 29.5 (3.0, 21.8)

T3: 49 (5.0, 36.2)

T4: 103 (10.5, 76)

T5: 181.5 (18.5, 134)

2. REAR DIFFERENTIAL WITH LSD

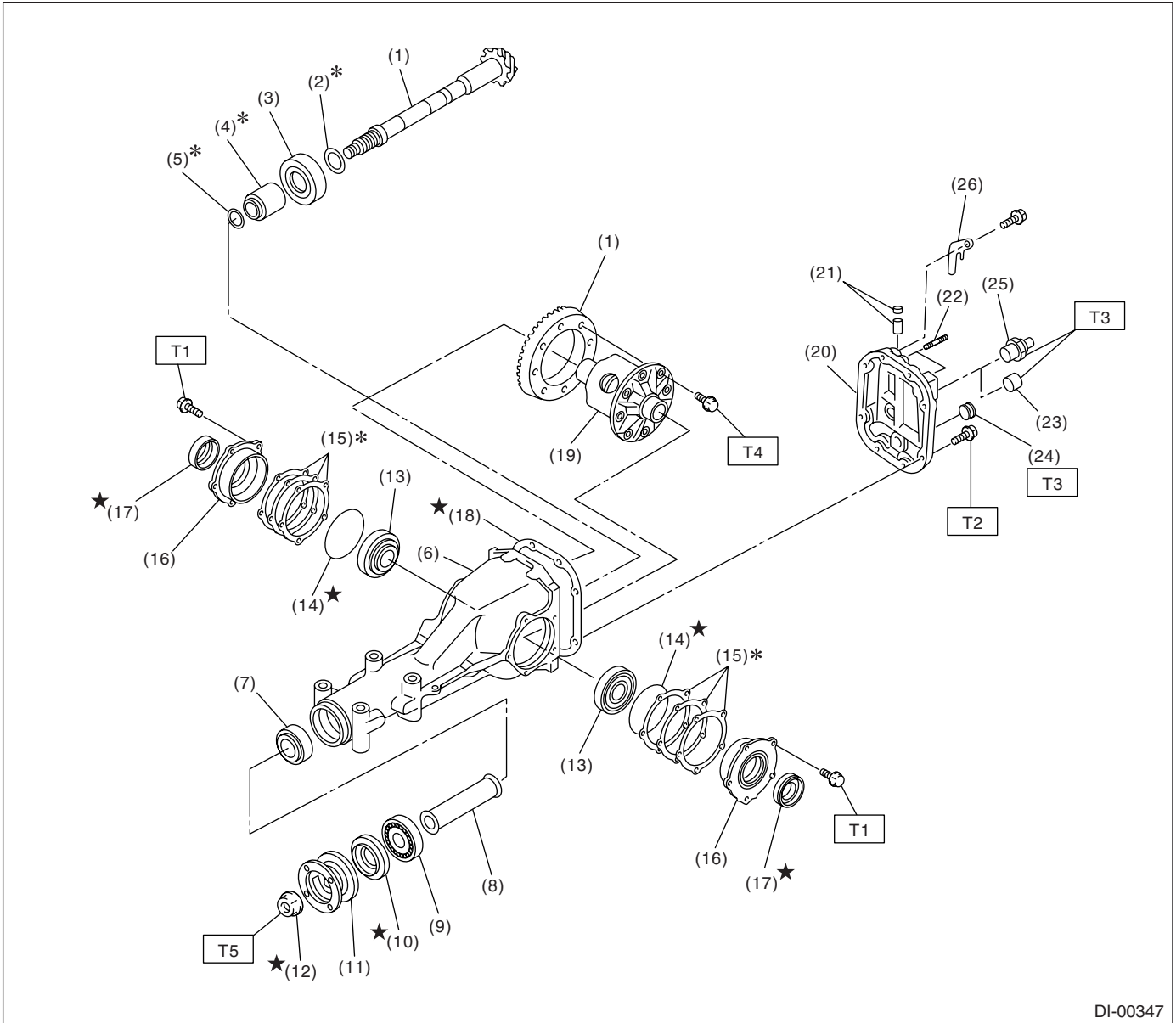

DI-00347

(1) Driven gear and drive pinion set	(14) O-ring	(24) Oil drain plug
(2) Pinion height adjusting washer	(15) Side bearing retainer shim	(25) Oil filler plug (Rear differential oil temperature switch) (STI model)
(3) Rear bearing	(16) Side bearing retainer	(26) Stay ground (STI model)
(4) Bearing preload adjusting spacer	(17) Side oil seal	
(5) Bearing preload adjusting washer	(18) Gasket	
(6) Differential carrier	(19) Differential case (Viscous coupling type) (Except STI model)	Tightening torque: N·m (kgf·m, ft·lb)
(7) Front bearing	(19) Differential case (Mechanical type) (STI model)	T1: 10.5 (1.1, 7.7)
(8) Collar		T2: 29.5 (3.0, 21.8) (Except STI model)
(9) Pilot bearing		44 (4.5, 32.5) (STI model)
(10) Front oil seal	(20) Rear cover	T3: 49 (5.0, 36.2)
(11) Companion flange	(21) Air breather cap	T4: 103 (10.5, 76)
(12) Self-locking nut	(22) Stud bolt	T5: 181.5 (18.5, 134)
(13) Side bearing	(23) Oil filler plug	

General Description

DIFFERENTIALS

3. REAR DIFFERENTIAL MOUNTING SYSTEM

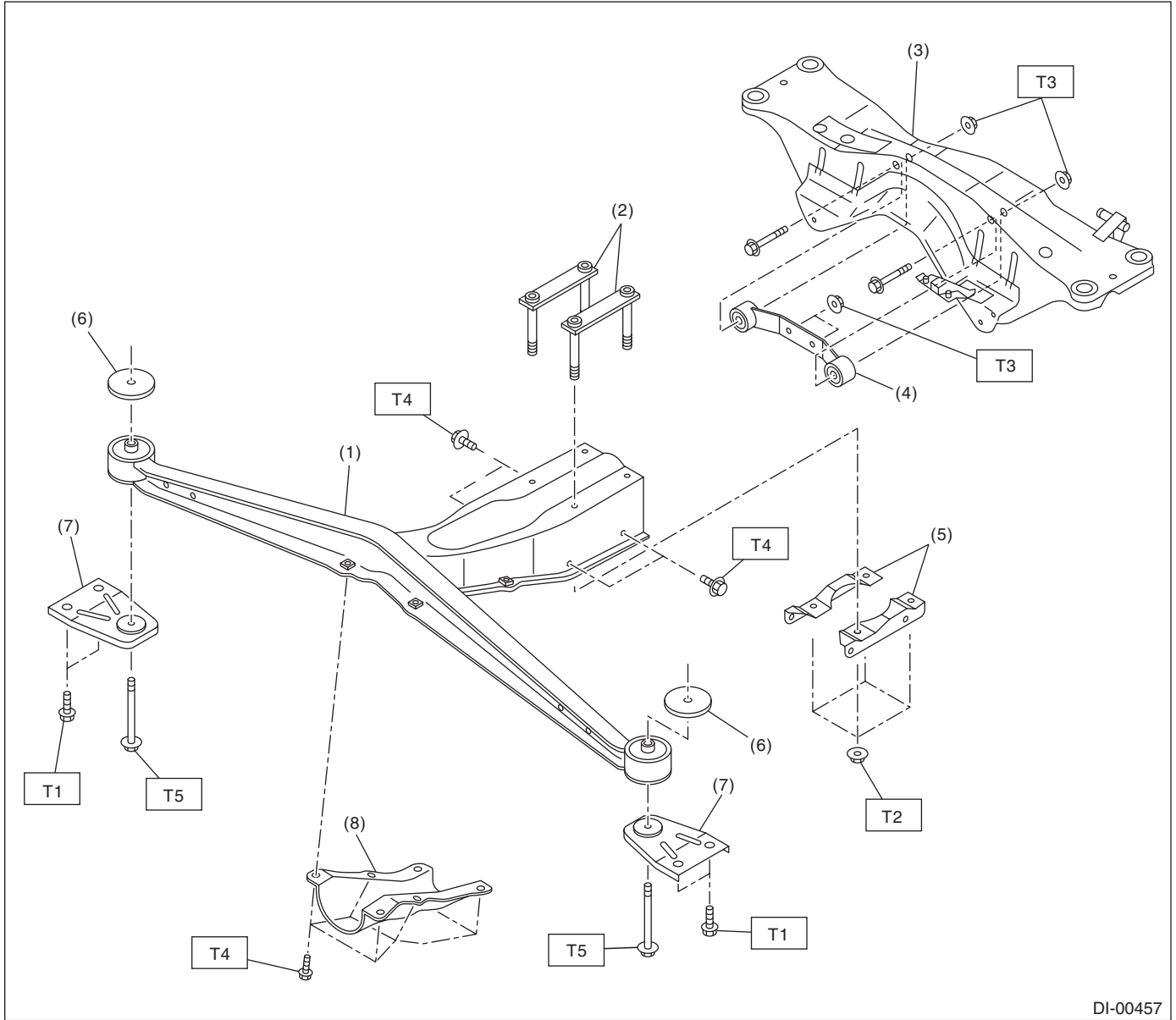

DI-00457

- | | |
|--------------------------------------|------------------------------------|
| (1) Differential front member | (7) Differential mount bracket |
| (2) Plate | (8) Differential mount front cover |
| (3) Crossmember | |
| (4) Differential rear member | |
| (5) Differential mount lower bracket | |
| (6) Stopper | |

Tightening torque: N·m (kgf·m, ft·lb)

T1: 33 (3.4, 24.3)

T2: 50 (5.1, 36.9)

T3: 70 (7.1, 51.6)

T4: 90 (9.2, 66.4)

T5: 100 (10.2, 73.8)

C: CAUTION

- Wear work clothing, including a cap, protective goggles, and protective shoes during operation.
- Remove contamination including dirt and corrosion before removal, installation or disassembly.
- Keep the disassembled parts in order and protect them from dust and dirt.
- Before removal, installation or disassembly, be sure to clarify the failure. Avoid unnecessary removal, installation, disassembly, and replacement.
- Be careful not to burn yourself, because each part on the vehicle is hot after running.
- Use SUBARU genuine gear oil, grease etc. or the equivalent. Do not mix gear oil, grease etc. with that of another grade or from other manufacturers.
- Be sure to tighten fasteners including bolts and nuts to the specified torque.
- Place shop jacks or rigid racks at the specified points.
- Apply gear oil onto sliding or revolution surfaces before installation.
- Before installing O-rings or snap rings, apply sufficient amount of gear oil to avoid damage and deformation.
- Before securing a part on a vise, place cushioning material such as wood blocks, aluminum plate, or shop cloth between the part and the vise.
- Avoid damaging the mating face of the case.

General Description

DIFFERENTIALS

D: PREPARATION TOOL

1. SPECIAL TOOL

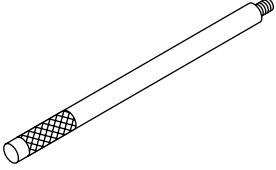
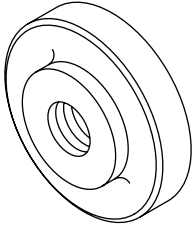
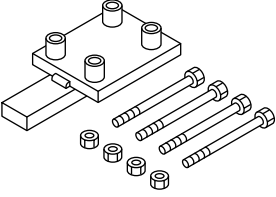
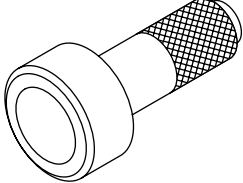
ILLUSTRATION	TOOL NUMBER	DESCRIPTION	REMARKS
 <p style="text-align: center;">ST-398477701</p>	398477701	HANDLE	Used for installing front and rear bearing cone.
 <p style="text-align: center;">ST-398477702</p>	398477702	DRIFT	Used for press-fitting the bearing race (front) of differential carrier.
 <p style="text-align: center;">ST-398217700</p>	398217700	ATTACHMENT SET	Stand for rear differential carrier disassembly and assembly.
 <p style="text-align: center;">ST-498447120</p>	498447120	INSTALLER	Used for installing front oil seal.

General Description

DIFFERENTIALS

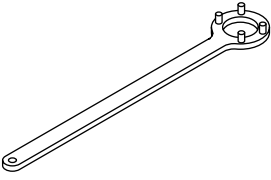
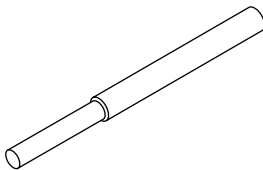
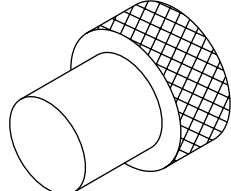
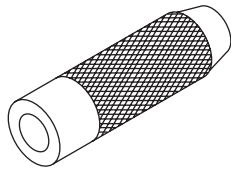
ILLUSTRATION	TOOL NUMBER	DESCRIPTION	REMARKS
 <p style="text-align: center;">ST-498427200</p>	498427200	FLANGE WRENCH	<ul style="list-style-type: none"> • Used for stopping rotation of companion flange when loosening and tightening self-locking nut. • For except STI model.
 <p style="text-align: center;">ST-398467700</p>	398467700	DRIFT	Used for removing pinion, pilot bearing and front bearing cone.
 <p style="text-align: center;">ST-399780104</p>	399780104	WEIGHT	Used for installing front bearing cone, pilot bearing companion flange.
 <p style="text-align: center;">ST-899580100</p>	899580100	INSTALLER	Used for press-fitting the front bearing cone, pilot bearing.

General Description

DIFFERENTIALS

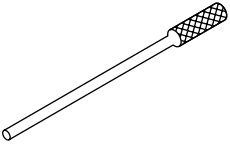
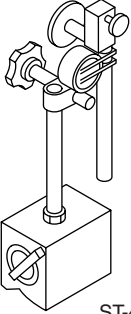
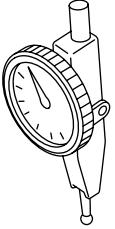
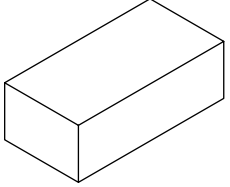
ILLUSTRATION	TOOL NUMBER	DESCRIPTION	REMARKS
 <p style="text-align: center;">ST-899904100</p>	899904100	STRAIGHT PIN REMOVER	Used for driving out differential pinion shaft lock pin.
 <p style="text-align: center;">ST-498247001</p>	498247001	MAGNET BASE	<ul style="list-style-type: none"> • Used for measuring backlash between side gear and pinion, and hypoid gear. • Used with DIAL GAUGE (498247100).
 <p style="text-align: center;">ST-498247100</p>	498247100	DIAL GAUGE	<ul style="list-style-type: none"> • Used measuring backlash between side gear and pinion, hypoid gear. • Used with MAGNET BASE (498247001).
 <p style="text-align: center;">ST-398507704</p>	398507704	BLOCK	Used for adjusting pinion height and preload.

General Description

DIFFERENTIALS

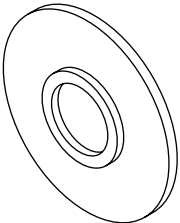
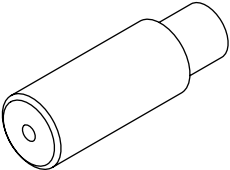
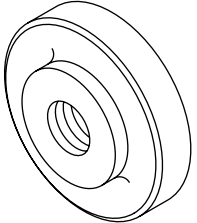
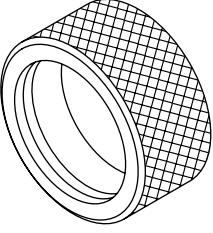
ILLUSTRATION	TOOL NUMBER	DESCRIPTION	REMARKS
 <p data-bbox="337 541 467 569">ST-398177700</p>	398177700	INSTALLER	Used for installing rear bearing cone.
 <p data-bbox="337 936 467 963">ST-398457700</p>	398457700	ATTACHMENT	Used for removing side bearing retainer.
 <p data-bbox="337 1325 467 1352">ST-398477703</p>	398477703	DRIFT2	Used for press-fitting the bearing race (rear) of differential carrier.
 <p data-bbox="337 1713 467 1740">ST-398437700</p>	398437700	DRIFT	Used for installing side oil seal.

General Description

DIFFERENTIALS

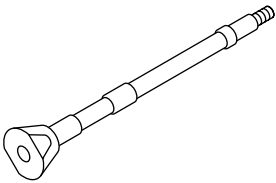
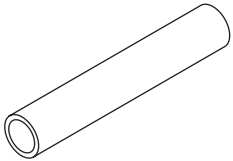
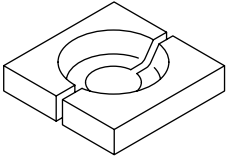
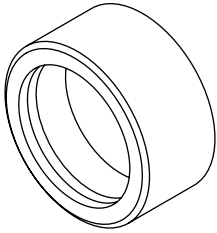
ILLUSTRATION	TOOL NUMBER	DESCRIPTION	REMARKS
 <p style="text-align: center;">ST-398507702</p>	398507702	DUMMY SHAFT	Used for adjusting pinion height and preload.
 <p style="text-align: center;">ST-398507703</p>	398507703	DUMMY COLLAR	Used for adjusting pinion height and preload.
 <p style="text-align: center;">ST-398517700</p>	398517700	REPLACER	Used for removing rear bearing cone.
 <p style="text-align: center;">ST-398487700</p>	398487700	DRIFT	Used for press-fitting the side bearing cone.

General Description

DIFFERENTIALS

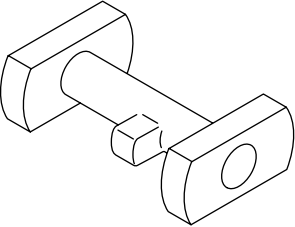
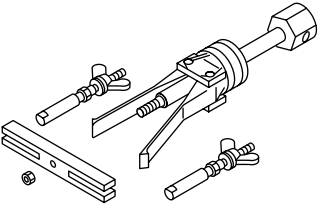
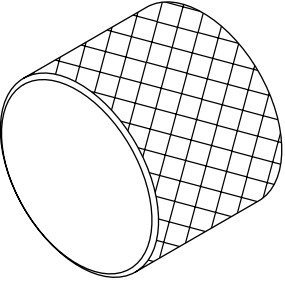
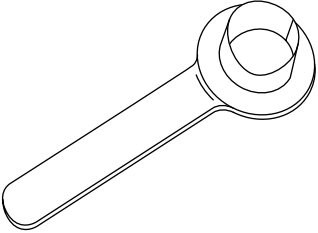
ILLUSTRATION	TOOL NUMBER	DESCRIPTION	REMARKS
 <p style="text-align: center;">ST-398507701</p>	398507701	DIFFERENTIAL CARRIER GAUGE	Used for adjusting pinion height.
 <p style="text-align: center;">ST-398527700</p>	398527700	PULLER ASSY	<ul style="list-style-type: none"> • Used for removing front oil seal. • Used for removing side bearing cup.
 <p style="text-align: center;">ST-398227700</p>	398227700	WEIGHT	Used for installing side bearing.
 <p style="text-align: center;">ST28099PA090</p>	28099PA090	OIL SEAL PROTEC- TOR	<ul style="list-style-type: none"> • Used for installing rear drive shaft into rear differential. • For protecting oil seal.

General Description

DIFFERENTIALS

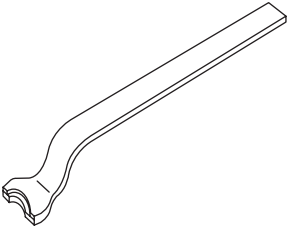
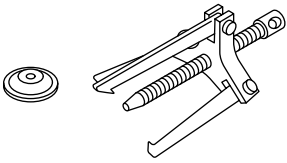
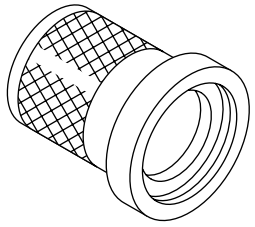
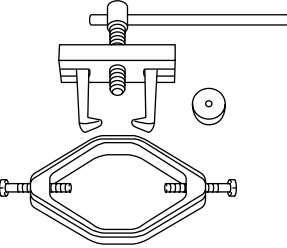
ILLUSTRATION	TOOL NUMBER	DESCRIPTION	REMARKS
 <p style="text-align: center;">ST28099PA100</p>	<p style="text-align: center;">28099PA100</p>	<p>DRIVE SHAFT REMOVER</p>	<p>Used for removing rear drive shaft from rear differential.</p>
 <p style="text-align: center;">ST-399703600</p>	<p style="text-align: center;">399703600</p>	<p>PULLER ASSY</p>	<p>Used for removing companion flange.</p>
 <p style="text-align: center;">ST-899874100</p>	<p style="text-align: center;">899874100</p>	<p>INSTALLER</p>	<p>Used for installing companion flange.</p>
 <p style="text-align: center;">ST18759AA000</p>	<p style="text-align: center;">18759AA000</p>	<p>PULLER ASSY</p>	<p>Used for removing side bearing cone of differential.</p>

General Description

DIFFERENTIALS

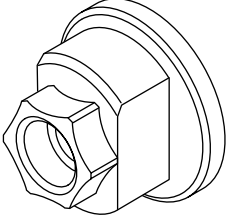
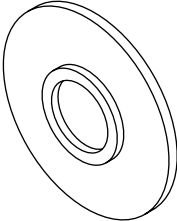
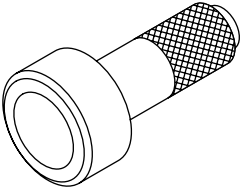
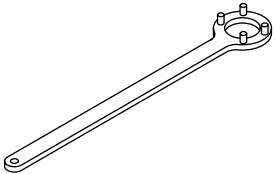
ILLUSTRATION	TOOL NUMBER	DESCRIPTION	REMARKS
 <p style="text-align: center;">ST-498937110</p>	498937110	HOLDER	<ul style="list-style-type: none"> • Used for installing pilot bearing. • For STI model.
 <p style="text-align: center;">ST18674AA000</p>	18674AA000	INSTALLER	<ul style="list-style-type: none"> • Used for installing rear bearing cone. • For STI model.
 <p style="text-align: center;">ST-398417700</p>	398417700	DRIFT	Used for installing side bearing race.
 <p style="text-align: center;">ST18633AA000</p>	18633AA000	WRENCH COMPL	<ul style="list-style-type: none"> • Used for stopping rotating of companion flange when loosening and tightening self-locking nut. • For STI model.

2. GENERAL TOOL

TOOL NAME	REMARKS
Transmission jack	Used for assembly/disassembly of rear differential.
Puller	Used for removal of side bearing retainer.
Thickness gauge	Used for measuring clearance.

Differential Gear Oil

DIFFERENTIALS

2. Differential Gear Oil

A: INSPECTION

1) Disconnect the oil temperature switch connector. (STI model)

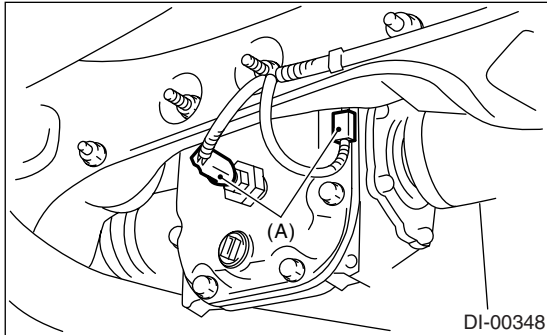

(A) Connector

2) Remove the filler plug or rear differential oil temperature switch and then check the gear oil. If it is contaminated or deteriorated, replace the gear oil. <Ref. to DI-18, REPLACEMENT, Differential Gear Oil.>

3) Check the gear oil level is up to the bottom part of filler bolt. If the level is low, refill up to the bottom of filler bolt.

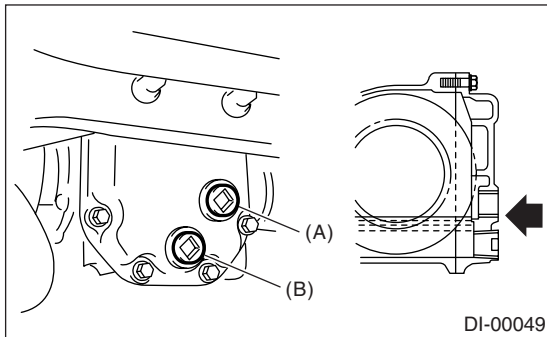

(A) Filler plug
(B) Drain plug

B: REPLACEMENT

1) Lift-up the vehicle.

2) Disconnect the oil temperature switch connector. (STI model)

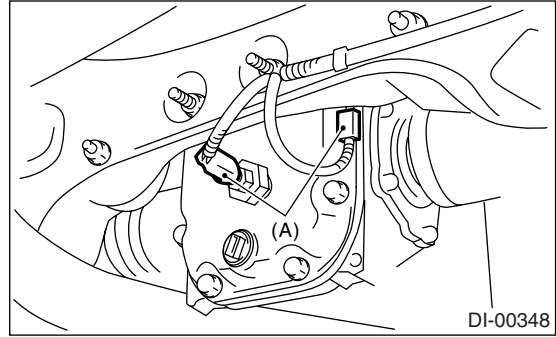

(A) Connector

3) Remove the oil drain plug and filler plug, and drain the gear oil.

CAUTION:

Be careful not to burn your hands, because gear oil becomes extremely hot after running.

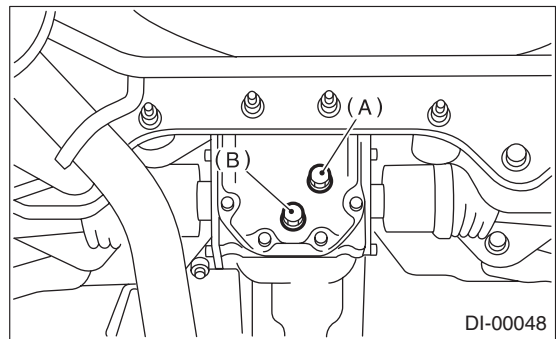

(A) Filler plug
(B) Drain plug

4) Tighten the oil drain plug.

NOTE:

Apply liquid gasket to the drain plug.

Liquid gasket:

THREE BOND 1105 (Part No. 004403010) or equivalent

Tightening torque:

49 N·m (5.0 kgf·m, 36.2 ft·lb)

5) Fill the differential carrier with gear oil to the upper plug level.

NOTE:

- Carefully refill oil while watching the level. Excess or insufficient oil must be avoided.
- Use gear oil for the mechanical LSD for STI model.

Recommended oil:

Except STI model:

GL-5 (75W-90) or equivalent

STI model:

GEAR OIL LSD (Part No. K0305Y0900), GL-5 (90) or equivalent

Oil capacity:

Except STI model:

0.8 ℓ (0.8 US qt, 0.7 Imp qt)

STI model:

1.0 ℓ (1.1 US qt, 0.9 Imp qt)

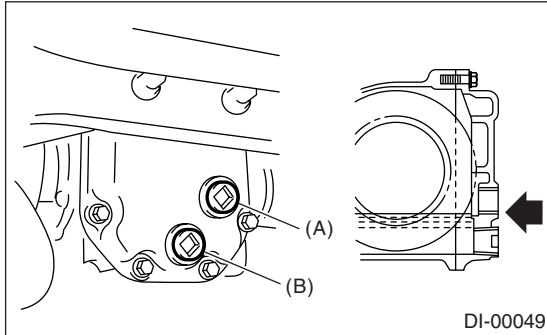

- (A) Filler plug
- (B) Drain plug

6) Install the filler plug or rear differential oil temperature switch.

NOTE:

Apply liquid gasket to the filler plug or rear differential oil temperature switch.

Liquid gasket:

THREE BOND 1105 (Part No. 004403010) or equivalent

Tightening torque:

49 N·m (5.0 kgf·m, 36.2 ft·lb)

7) Connect the oil temperature switch connector.
(STI model)

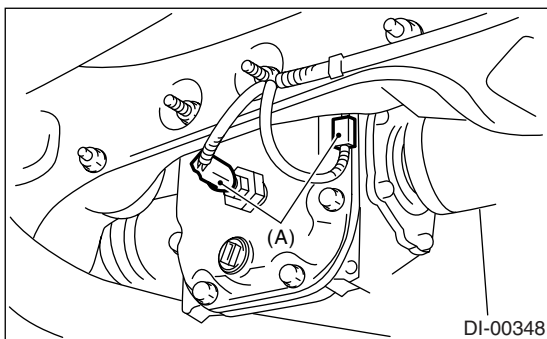

- (A) Connector

3. Front Differential Assembly

A: NOTE

1. AT MODEL

For front differential of AUTOMATIC TRANSMISSION, refer to "AT" section. <Ref. to 4AT-99, Front Differential Assembly.>

2. MT MODEL

For front differential of manual transmission, refer to "5MT" or "6MT" section. <Ref. to 5MT-68, Front Differential Assembly.> <Ref. to 6MT-102, Front Differential Assembly.>

4. Rear Differential

A: REMOVAL

- 1) Set the vehicle on a lift.
- 2) Disconnect the ground cable from battery.
- 3) Move the select lever or gear shift lever to "N".
- 4) Release the parking brake.
- 5) Loosen the wheel nut.
- 6) Jack-up the vehicle and support it with sturdy racks.
- 7) Remove the wheel.
- 8) Disconnect the connector from oil temperature switch. (STI model)

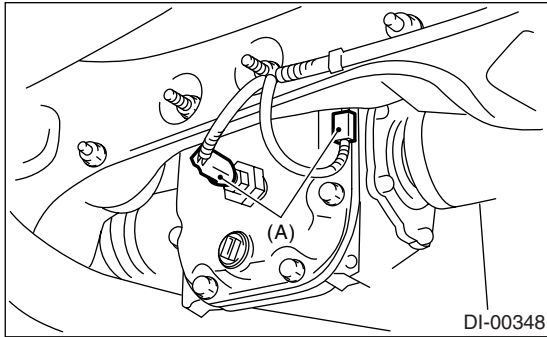

(A) Connector

- 9) Remove the rear exhaust pipe and muffler.
SOHC model
<Ref. to EX(H4SO)-7, REMOVAL, Rear Exhaust Pipe.> <Ref. to EX(H4SO)-8, REMOVAL, Muffler.>
DOHC Turbo model
<Ref. to EX(H4DOTC)-15, REMOVAL, Rear Exhaust Pipe.> <Ref. to EX(H4DOTC)-16, REMOVAL, Muffler.>
- 10) Remove the front cover of rear differential mount.

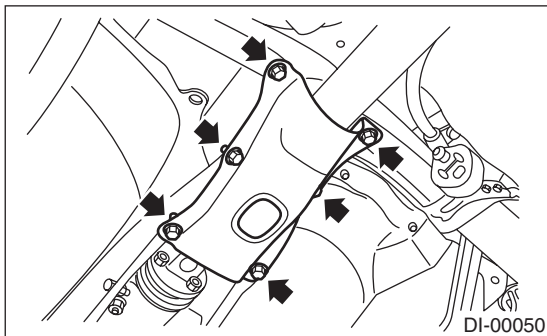

- 11) Remove the propeller shaft. <Ref. to DS-16, REMOVAL, Propeller Shaft.>
- 12) Remove the rear differential protector. (If equipped)
- 13) Remove the DOJ of rear drive shaft from rear differential.

- (1) Remove the ABS wheel speed sensor cable clamp and parking brake cable clamp from bracket.

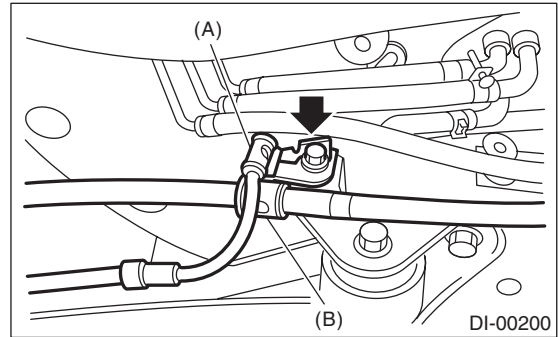

(A) ABS wheel speed sensor cable clamp
(B) Parking brake cable clamp

- (2) Remove the ABS wheel speed sensor cable clamp from trailing link.

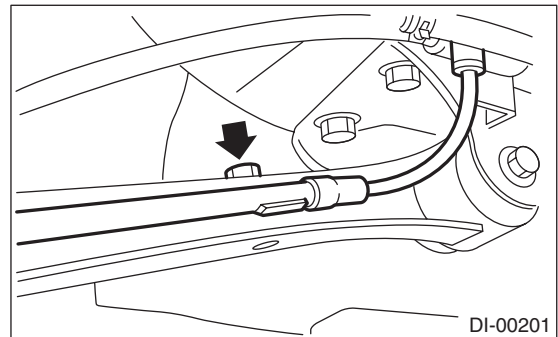

- (3) Remove the ABS wheel speed sensor cable clamp and parking brake cable guide from trailing link.

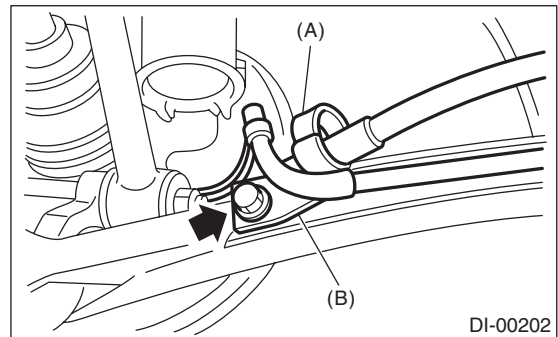

(A) Parking brake cable guide
(B) ABS wheel speed sensor cable clamp

Rear Differential

DIFFERENTIALS

(4) Remove the rear stabilizer link.

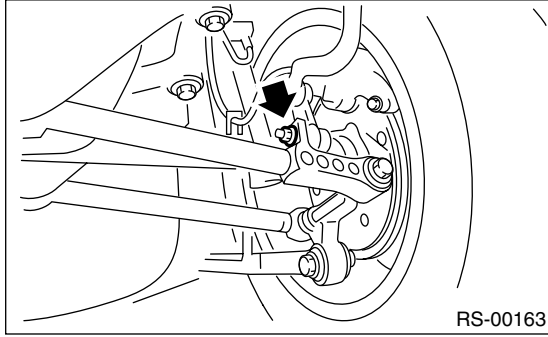

(5) Remove the bolts which secure trailing link to housing.

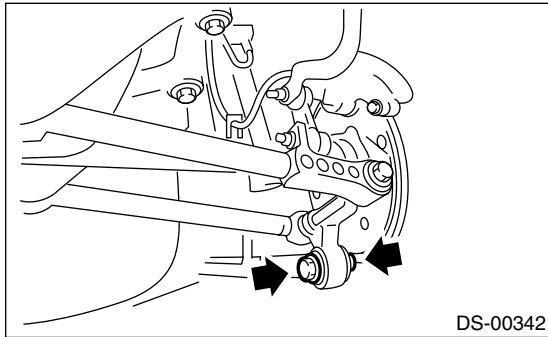

(6) Remove the bolts which secure the front and rear lateral link to rear housing.

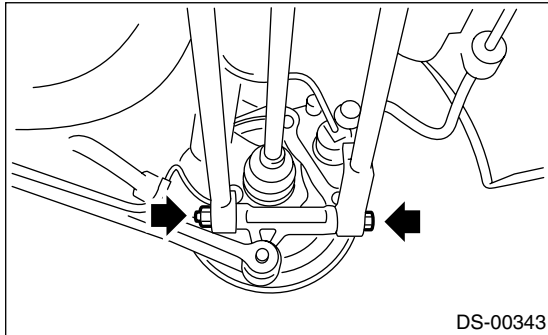

(7) Remove the DOJ from the rear differential by using ST.

NOTE:

When removing the DOJ from rear differential, fit ST to the bolts as shown in the figure so as not to damage the side bearing retainer.

ST 208099PA100 DRIVE SHAFT REMOVER

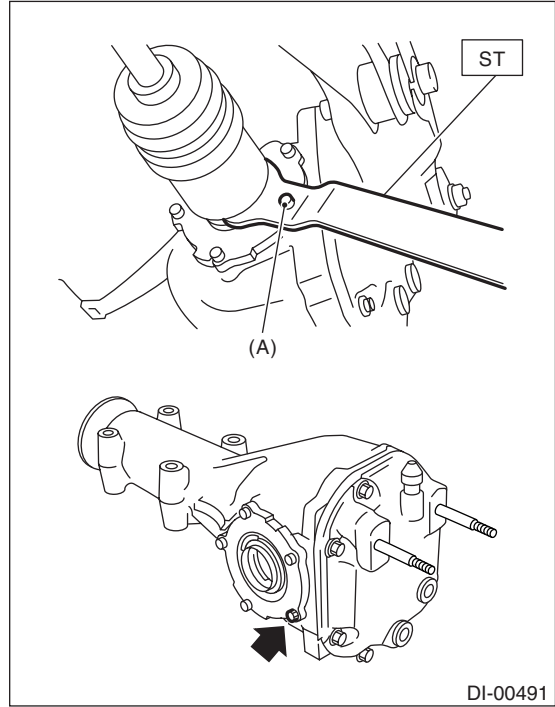

(A) Bolt

14) Secure the rear drive shaft to rear crossmember using wire.

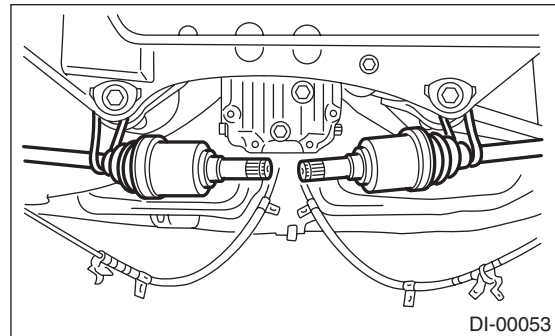

15) Remove the differential mount lower bracket.

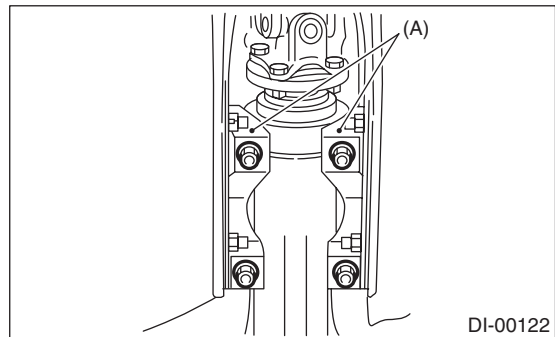

(A) Differential mount lower bracket

16) Support the rear differential with transmission jack.

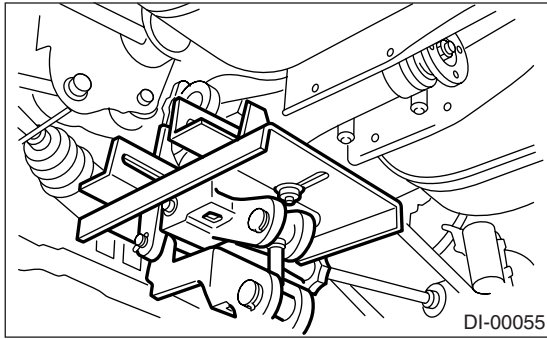

DI-00055

17) Remove the self-locking nuts and bolts.

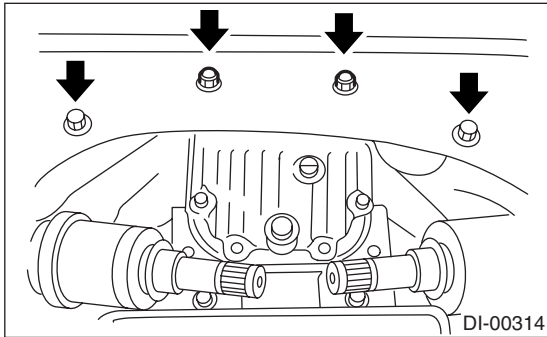

DI-00314

18) Remove the bolts which secure the front differential member to body.

Loosen the bolt A first, then remove the bolts B.

NOTE:

Support the differential front member with use of a helper to prevent it from dropping.

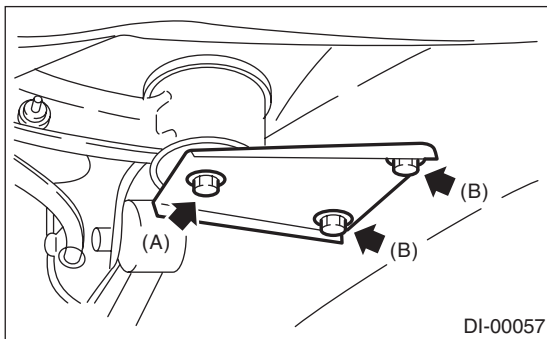

DI-00057

(A) Bolt A

(B) Bolt B

19) Remove the bolt A.

20) While slowly lowering the transmission jack, move the rear differential forward and remove differential front member and rear differential from vehicle.

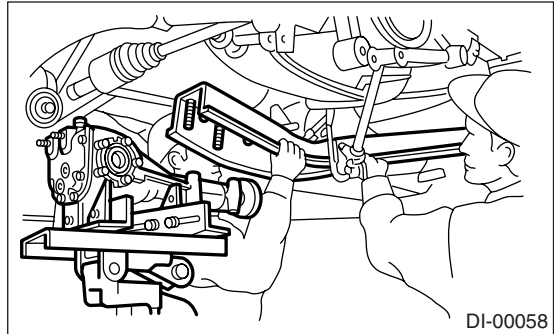

DI-00058

21) Remove the rear differential from vehicle.

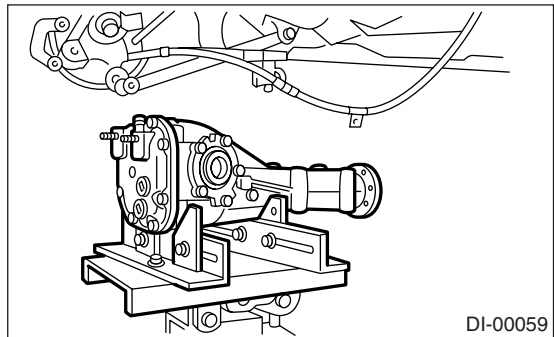

DI-00059

B: INSTALLATION

1) Install the air breather cap tapping with a plastic hammer.

NOTE:

Be sure to install a new air breather cap.

2) Position the differential front member on body by passing it under the parking brake cable and securing to rear differential.

NOTE:

When installing the differential front member of rear differential, do not confuse the installation sequence of the upper and lower stoppers.

3) Install the DOJ of drive shaft into rear differential. <Ref. to DI-50, REPLACEMENT, Rear Differential Side Oil Seal.>

ST 28099PA090 OIL SEAL PROTECTOR

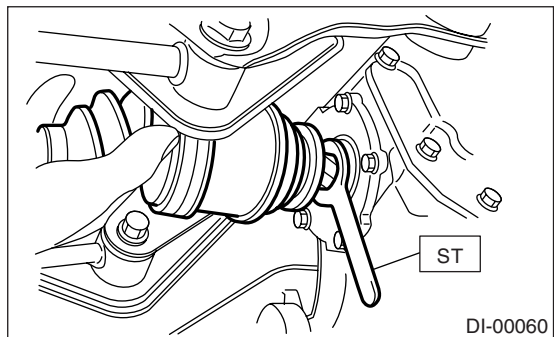

DI-00060

Rear Differential

DIFFERENTIALS

4) Installing procedure hereafter is in the reverse order of removal.

5) After installation, fill the differential carrier with gear oil to the filler plug level. <Ref. to DI-18, Differential Gear Oil.>

C: DISASSEMBLY

1. EXCEPT STI MODEL

To detect the real cause of trouble, inspect the following items before disassembling.

- Tooth contact of hypoid driven gear and pinion, and backlash
- Runout of hypoid driven gear at its back surface
- Total preload of drive pinion

1) Set the ST on vise and install the differential assembly to ST.

ST 398217700 ATTACHMENT

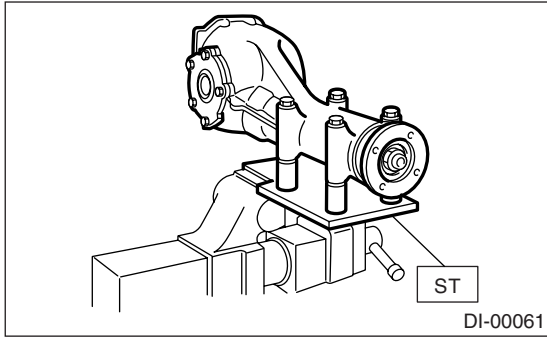

2) Drain the gear oil by removing the plug.

3) Remove the air breather cap.

NOTE:

- Do not attempt to remove the air breather cap if unnecessary.
- When removing the air breather cap, replace the air breather cap with a new one.

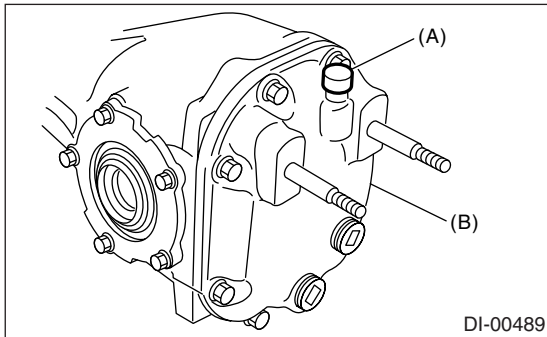

(A) Air breather cap

(B) Rear cover

4) Remove the bolts, and then remove the rear cover.

NOTE:

Remove it by tapping with plastic hammer.

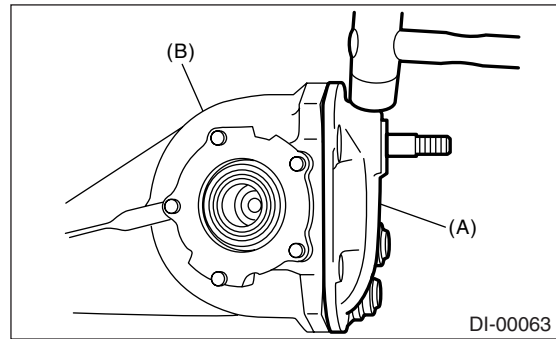

(A) Rear cover

(B) Differential carrier

5) Make right and left side bearing retainers in order to identify them at reassembly. Remove the side bearing retainer attaching bolts, set the ST to differential case, and extract right and left side bearing retainers with a puller.

NOTE:

Each shim, which is installed to adjust the side bearing preload, should be kept together with its mating retainer.

ST 398457700 ATTACHMENT

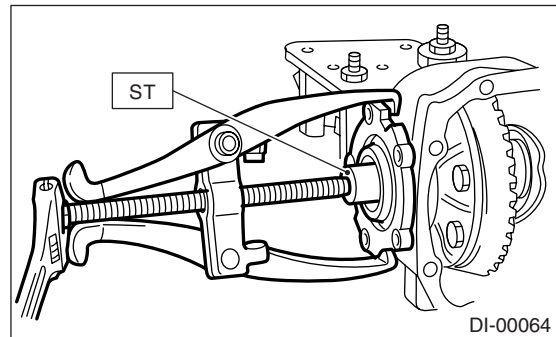

6) Pull out the differential case assembly from differential carrier.

NOTE:

Be careful not to hit the teeth against the case.

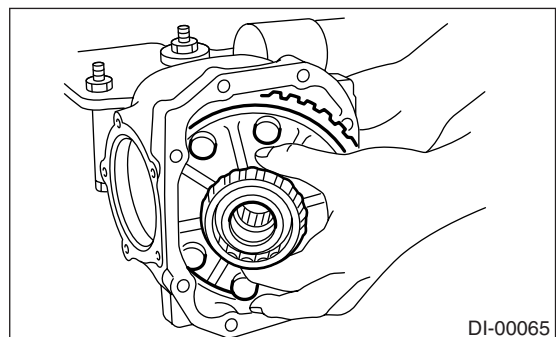

7) When replacing the side bearing, pull the bearing cup from side bearing retainer using ST.

ST 398527700 PULLER ASSY

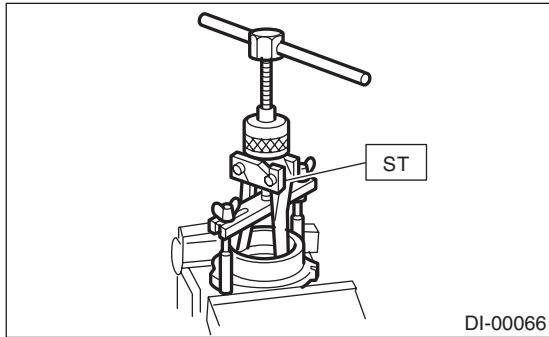

8) Extract the bearing cone with ST.

NOTE:

- Do not attempt to disassemble the parts unless necessary.
- Set the puller so that its claws catch the edge of bearing cone.
- Never mix up the right and left hand bearing races and cones.

ST 18759AA000 PULLER ASSY

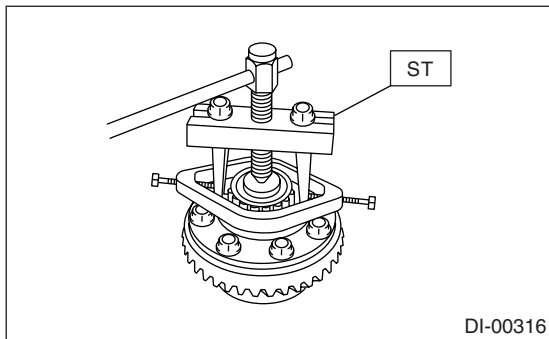

9) Remove the hypoid driven gear by loosening the hypoid driven gear bolts.

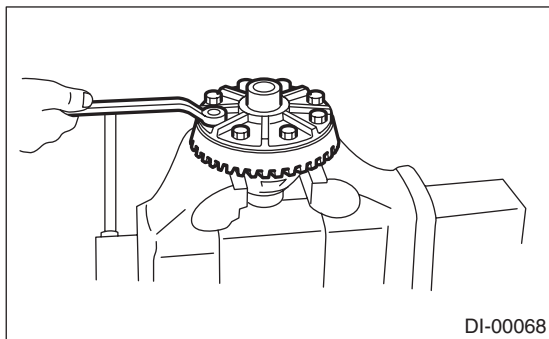

10) Drive out the pinion shaft lock pin from hypoid driven gear side. (Model without LSD)

NOTE:

The lock pin is staked at the pin hole end on the differential carrier; do not drive it out forcibly before unstaking it.

ST 899904100 STRAIGHT PIN REMOVER

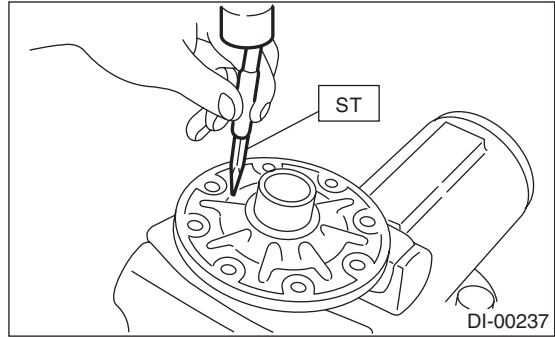

11) Draw out the pinion mate shaft and remove the pinion mate gears, side gears and thrust washers. (Model without LSD)

NOTE:

The gears as well as thrust washers should be marked or kept separated right and left, front and rear.

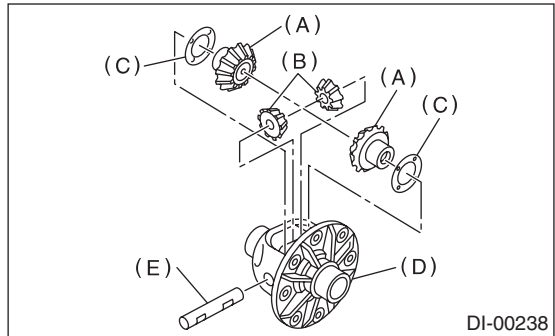

- (A) Side gear
- (B) Pinion mate gear
- (C) Thrust washer
- (D) Differential case
- (E) Pinion mate shaft

12) Hold the companion flange with ST and remove self-locking nut.

ST 498427200 FLANGE WRENCH

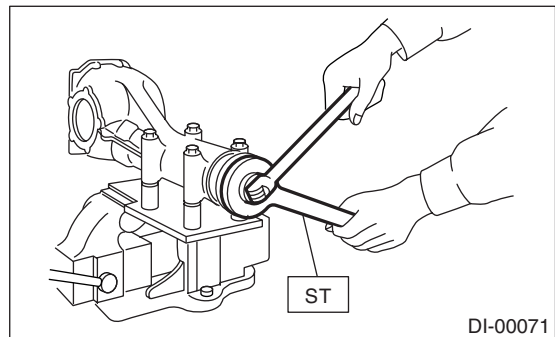

Rear Differential

DIFFERENTIALS

13) Extract the companion flange with a puller.

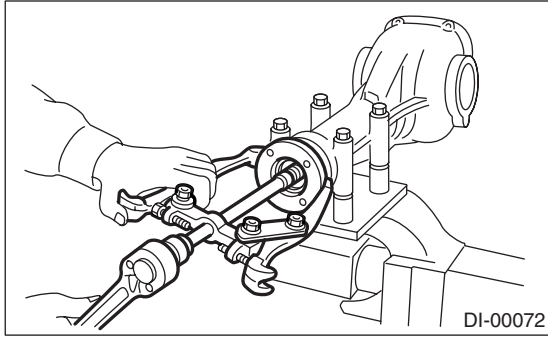

ST 398527700 PULLER ASSY

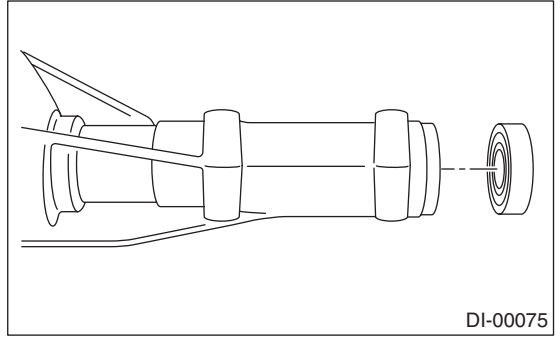

14) Press the end of drive pinion shaft and extract it together with the rear bearing cone, preload adjusting spacer and washer.

NOTE:

Hold the drive pinion so as not to drop it.

ST 398467700 DRIFT

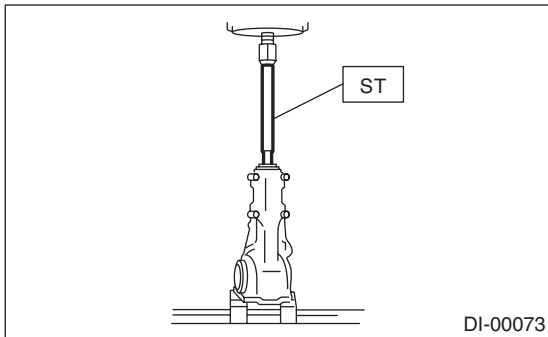

17) Remove the pilot bearing together with front bearing cone and spacer using ST.

ST 398467700 DRIFT

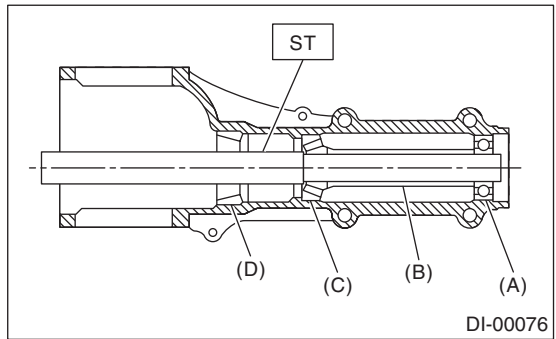

- (A) Pilot bearing
- (B) Spacer
- (C) Front bearing
- (D) Rear bearing cup

15) Remove the rear bearing cone from drive pinion by supporting the cone with ST.

NOTE:

Place the replacer so that its center-recessed side faces the pinion gear.

ST 398517700 REPLACER

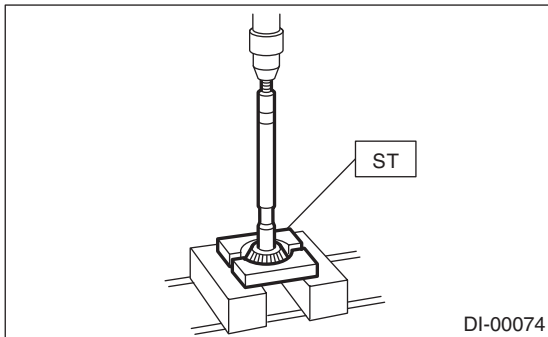

18) When replacing the bearings, hit out the front bearing cup and rear bearing cup in this order out of case by using a brass bar.

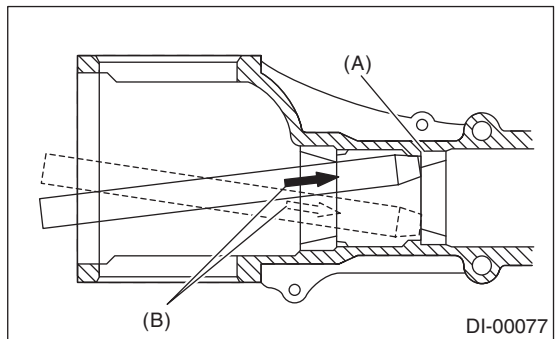

- (A) 2 cutouts along diagonal lines
- (B) Hit out alternately with brass bar.

16) Remove the front oil seal from differential carrier using ST.

2. STI MODEL

To detect the real cause of trouble, inspect the following items before disassembling.

- Tooth contact of hypoid driven gear and pinion, and backlash
- Runout of hypoid driven gear at its back surface
- Total preload of drive pinion

1) Set the ST on vise and install the differential assembly to ST.

ST 398217700 ATTACHMENT

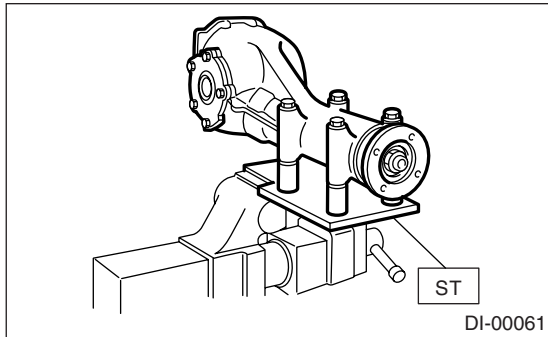

2) Drain the gear oil by removing the plug.

3) Remove the air breather cap.

NOTE:

- Do not attempt to remove the air breather cap if unnecessary.
- When removing the air breather cap, replace the air breather cap with a new one.

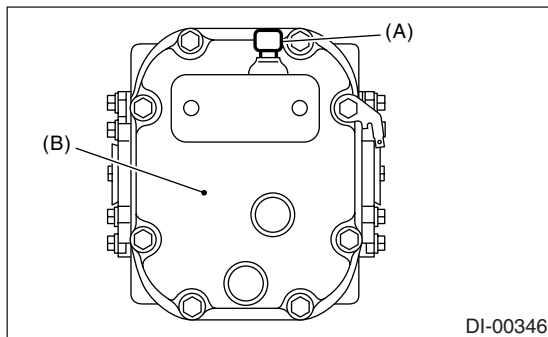

(A) Air breather cap

(B) Rear cover

4) Remove the bolts, and then remove the rear cover.

NOTE:

Remove it by tapping with plastic hammer.

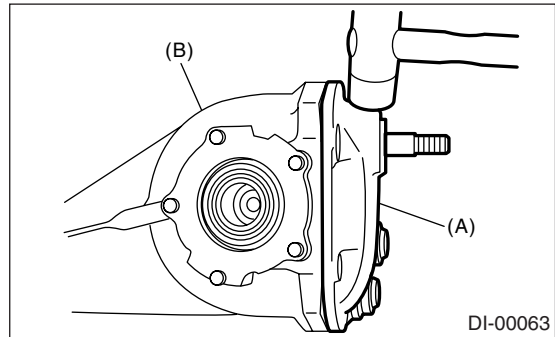

(A) Rear cover

(B) Differential carrier

5) Make right and left side bearing retainers in order to identify them at reassembly. Remove the side bearing retainer attaching bolts, set the ST to differential case, and extract right and left side bearing retainers with a puller.

NOTE:

Each shim, which is installed to adjust the side bearing preload, should be kept together with its mating retainer.

ST 398457700 ATTACHMENT

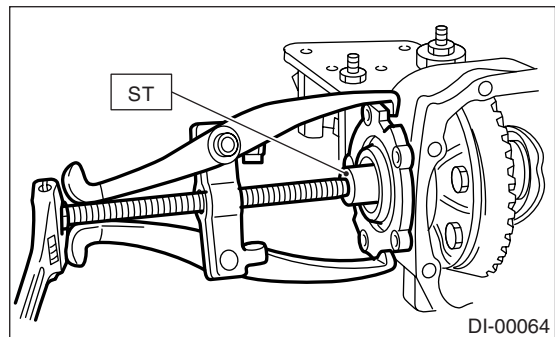

6) Pull out the differential case assembly from differential carrier.

NOTE:

Be careful not to hit the teeth against the case.

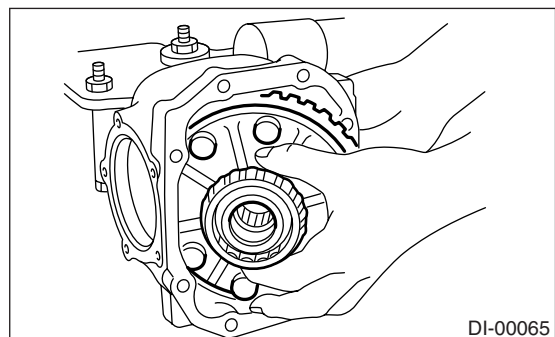

Rear Differential

DIFFERENTIALS

7) When replacing the side bearing, pull the bearing cup from side bearing retainer using ST.

ST 398527700 PULLER ASSY

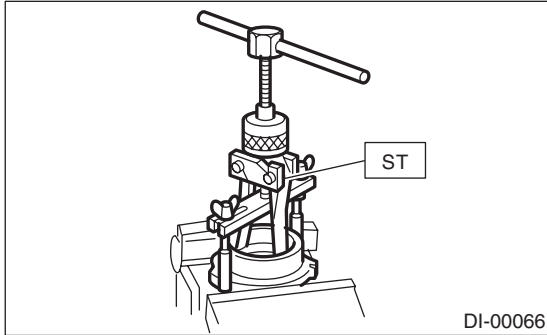

8) Extract the bearing cone with ST.

NOTE:

- Do not attempt to disassemble the parts if unnecessary.
- Set the puller so that its claws catch the edge of bearing cone.
- Never mix up the right and left hand bearing races and cones.

ST 18759AA000 PULLER ASSY

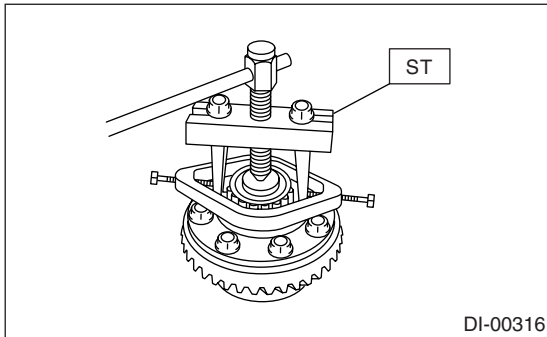

9) Remove the hypoid driven gear by loosening the hypoid driven gear bolts.

NOTE:

Disassembling the differential case is not allowed.

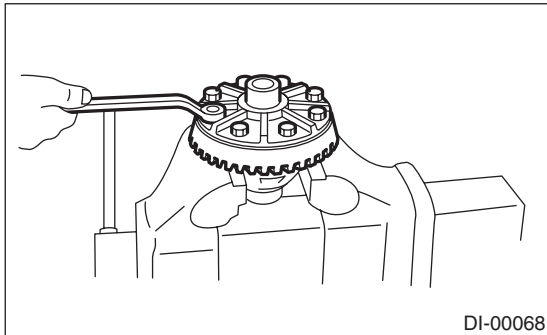

10) Hold the companion flange with ST and remove self-locking nut.

ST 18633AA000 WRENCH COMPL

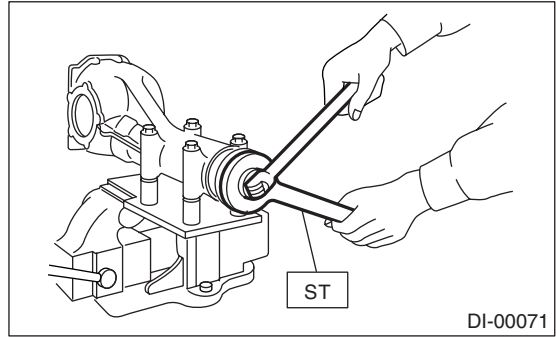

11) Extract the companion flange with a puller.

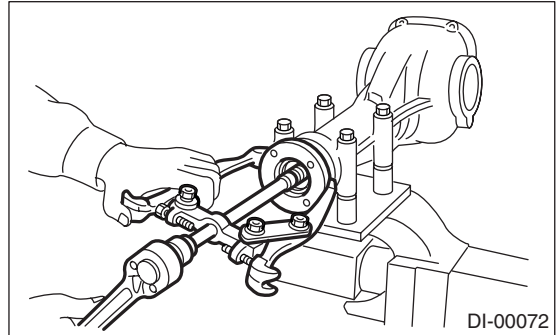

12) Press the end of drive pinion shaft and extract it together with the rear bearing cone, preload adjusting spacer and washer.

NOTE:

Hold the drive pinion so as not to drop it.

ST 398467700 DRIFT

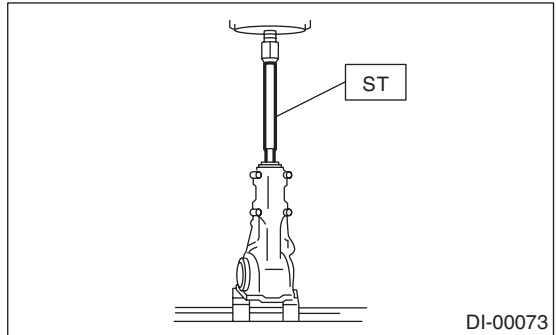

13) Remove the rear bearing cone from drive pinion.

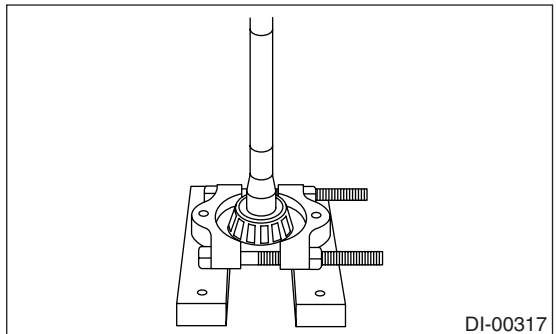

14) Remove the front oil seal from differential carrier using ST.

ST 398527700 PULLER ASSY

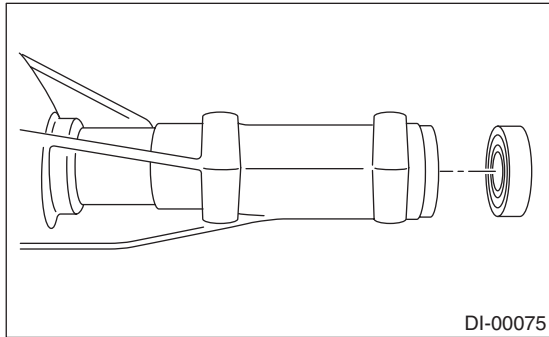

15) Remove the pilot bearing together with front bearing cone and spacer using ST.

ST 398467700 DRIFT

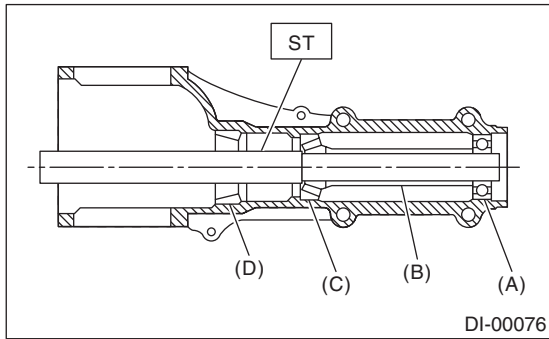

- (A) Pilot bearing
- (B) Spacer
- (C) Front bearing
- (D) Rear bearing cup

16) When replacing the bearings, tap the front bearing cup and rear bearing cup in this order out of case by using a brass bar.

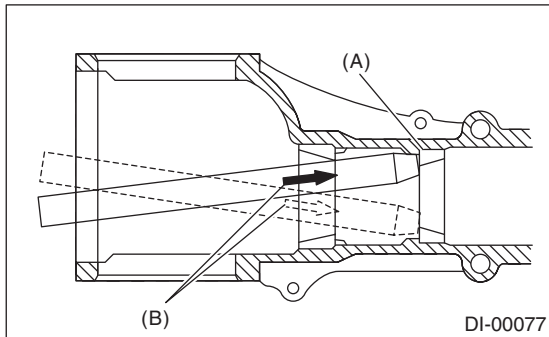

- (A) 2 cutouts along diagonal lines
- (B) Hit out alternately with brass bar.

D: ASSEMBLY

1. EXCEPT STI MODEL

NOTE:

- Assemble in the reverse order of disassembling.
- Check and adjust each part during assembly.
- Keep the shims and washers in order, so that they are not improperly installed.
- Thoroughly clean the surfaces on which the shims, washers and bearings are to be installed.
- Apply gear oil when installing the bearings and thrust washers.
- Be careful not to mix up the right and left hand races of the bearings.
- Use a new O-ring and gasket.
- Replace the oil seal with a new one at every disassembly. Apply chassis grease between the lips when installing the oil seal.
- Be careful not to confuse the installing direction of oil seal.

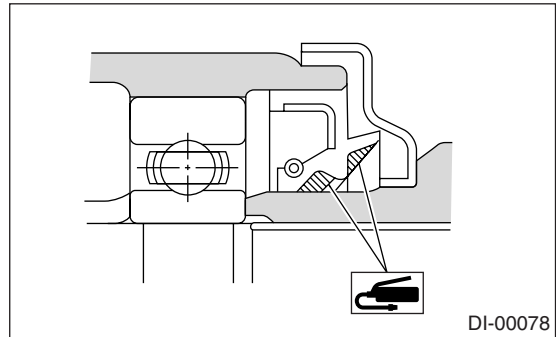

1) Adjusting preload for front and rear bearings

Adjust the bearing preload with spacer and washer between front and rear bearings. Pinion height adjusting washer are not affected by this adjustment. The adjustment must be carried out without oil seal inserted.

(1) Press the rear bearing race into differential carrier using ST1 and ST2.

ST1 398477701 HANDLE
ST2 398477703 DRIFT 2

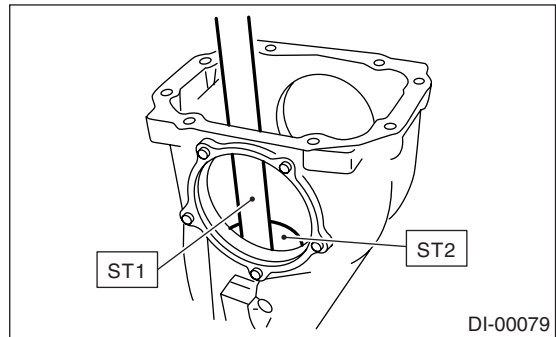

Rear Differential

DIFFERENTIALS

(2) Install the front bearing race to differential carrier using ST1 and ST2.

ST1 398477701 HANDLE

ST2 398477702 DRIFT

(3) Insert the ST1 into carrier with pinion height adjusting washer and rear bearing cone fitted onto it.

NOTE:

- If tooth contact (Drive pinion, Hypoid driven gear) is normal in the inspection before disassembling, verify that the washer is not deformed, and then re-use the used washer.

- Use a new rear bearing cone.

(4) Then install the preload adjusting spacer and washer, front bearing cone, ST2, companion flange, and washer and drive pinion nut.

ST1 398507702 DUMMY SHAFT

ST2 398507703 DUMMY COLLAR

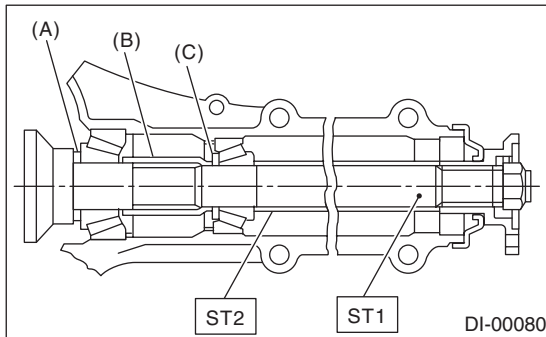

- (A) Pinion height adjusting washer
- (B) Preload adjusting spacer
- (C) Preload adjusting washer

(5) Turn the ST1 with hand to make the bearing accustomed, and tighten the self-locking nut while measuring the starting load or starting torque with spring balance or torque wrench. Select the preload adjusting washer and spacer so that the specified preload is obtained when nut is tightened to the specified torque.

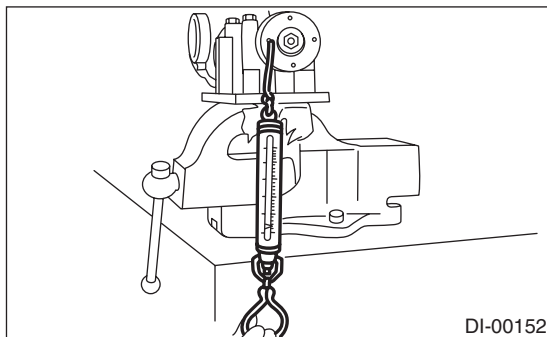

NOTE:

- Use a new self-locking nut.
- Be careful not to give excessive preload.

- When tightening the self-locking nut, lock ST1 with ST2 as shown in the figure.

- Measure the preload in direction of tangent to flange.

ST1 398507702 DUMMY SHAFT

ST2 398507704 BLOCK

Tightening torque:

181.5 N·m (18.5 kgf·m, 134 ft·lb)

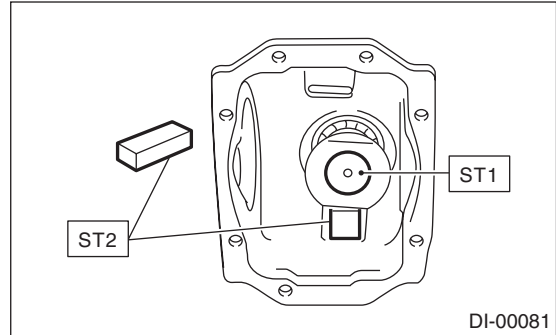

Starting load:

17.7 — 38.8 N (1.8 — 4.0 kgf, 4.0 — 8.7 lbf)

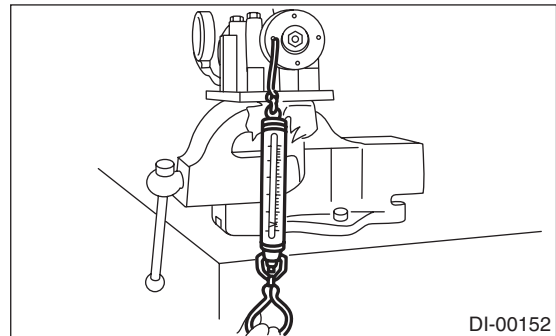

Starting torque:

0.48 — 1.22 N·m (0.045 — 0.124 kgf·m, 0.32 — 0.9 ft·lb)

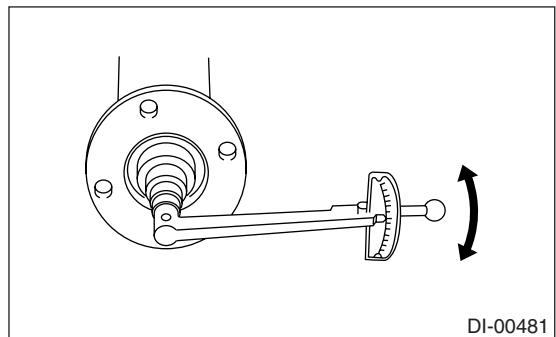

Preload adjusting washer	Part No.	Thickness mm (in)
	383705200	2.59 (0.1020)
	383715200	2.57 (0.1012)
	383725200	2.55 (0.1004)
	383735200	2.53 (0.0996)
	383745200	2.51 (0.0988)
	383755200	2.49 (0.0980)
	383765200	2.47 (0.0972)
	383775200	2.45 (0.0965)
	383785200	2.43 (0.0957)
	383795200	2.41 (0.0949)
	383805200	2.39 (0.0941)
	383815200	2.37 (0.0933)
	383825200	2.35 (0.0925)
	383835200	2.33 (0.0917)
383845200	2.31 (0.0909)	

Preload adjusting spacer	Part No.	Length mm (in)
	383695201	56.2 (2.213)
	383695202	56.4 (2.220)
	383695203	56.6 (2.228)
	383695204	56.8 (2.236)
	383695205	57.0 (2.244)
	383695206	57.2 (2.252)

NOTE:

Make sure there is no clearance between the case and ST2.

- ST1 398507702 DUMMY SHAFT
- ST2 398507701 DIFFERENTIAL CARRIER GAUGE

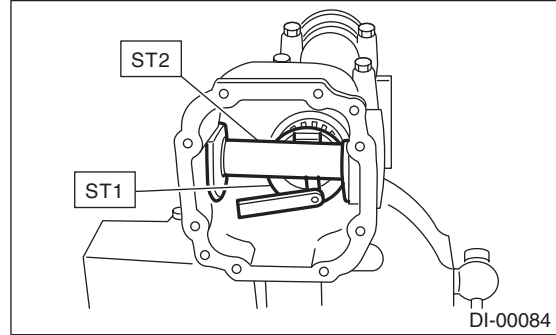

(3) Obtain the thickness of pinion height adjusting washer to be inserted from the following formula, and replace the temporarily installed shim with this one.

$$T = T_o + N - (H \times 0.01) - 0.20 \text{ mm (0.0079 in)}$$

NOTE:

Use copies of this page.

T	Thickness of pinion height adjusting washer	mm (in)	
T _o	Thickness of washer temporarily inserted	mm (in)	
N	Reading of thickness gauge	mm (in)	
H	Figure marked on drive pinion head		
Memo:			

2) Drive pinion height adjustment

Adjust the drive pinion height with shim installed between the rear bearing cone and back of pinion gear.

(1) Install the ST2.

NOTE:

At this time, install a pinion height adjusting washer which is temporarily selected or the same as that used before. Measure and record the thickness.

- ST1 398507702 DUMMY SHAFT
- ST2 398507701 DIFFERENTIAL CARRIER GAUGE
- ST3 398507703 DUMMY COLLAR

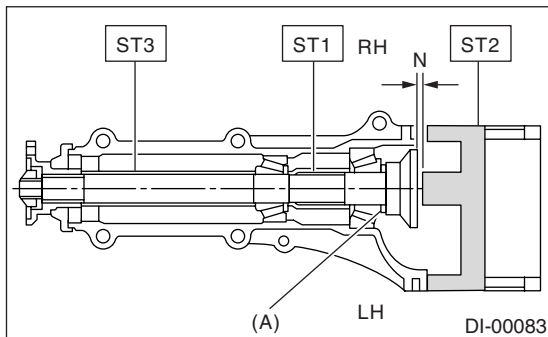

(A) Pinion height adjusting washer

(2) Measure the clearance N between the end of ST2 and end surface of ST1 by using a thickness gauge.

(Example of calculation)

$$T_o = 2.20 + 1.20 = 3.40 \text{ mm}$$

$$N = 0.23 \text{ mm}$$

$$H = + 1$$

$$T = 3.40 + 0.23 - 0.01 - 0.20 = 3.42$$

Result: Thickness = 3.42 mm

Therefore use the washer 383605200.

Pinion height adjusting washer	
Part No.	Thickness mm (in)
383495200	3.09 (0.1217)
383505200	3.12 (0.1228)
383515200	3.15 (0.1240)
383525200	3.18 (0.1252)
383535200	3.21 (0.1264)
383545200	3.24 (0.1276)
383555200	3.27 (0.1287)
383565200	3.30 (0.1299)
383575200	3.33 (0.1311)
383585200	3.36 (0.1323)

Rear Differential

DIFFERENTIALS

Pinion height adjusting washer	
Part No.	Thickness mm (in)
383595200	3.39 (0.1335)
383605200	3.42 (0.1346)
383615200	3.45 (0.1358)
383625200	3.48 (0.1370)
383635200	3.51 (0.1382)
383645200	3.54 (0.1394)
383655200	3.57 (0.1406)
383665200	3.60 (0.1417)
383675200	3.63 (0.1429)
383685200	3.66 (0.1441)

3) Install the selected pinion height adjusting washer on drive pinion, and press the rear bearing cone into position with ST.

ST 398177700 INSTALLER

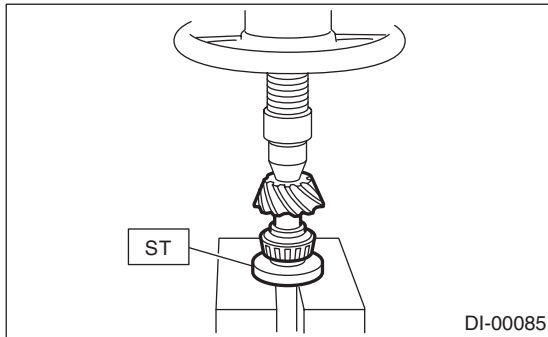

4) Insert the drive pinion into differential carrier, install the previously selected bearing preload adjusting spacer and washer.

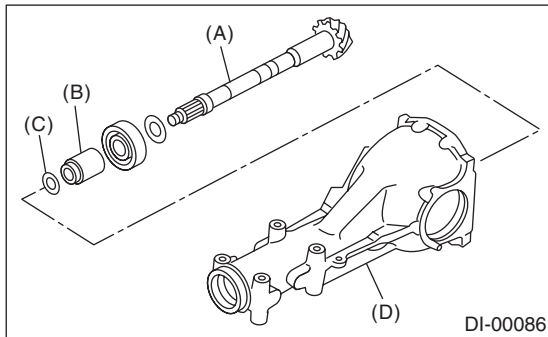

- (A) Drive pinion
- (B) Bearing preload adjusting spacer
- (C) Bearing preload adjusting washer
- (D) Differential carrier

5) Press-fit the front bearing cone into case with ST1, ST2 and ST3.

ST1 398507703 DUMMY COLLAR
ST2 399780104 WEIGHT

ST3 899580100 INSTALLER

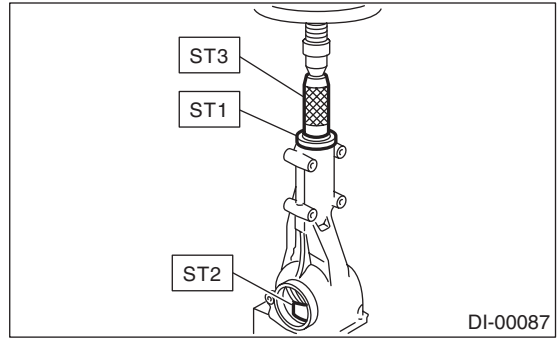

6) Insert the spacer, then press-fit the pilot bearing with ST1 and ST2.

ST1 399780104 WEIGHT
ST2 899580100 INSTALLER

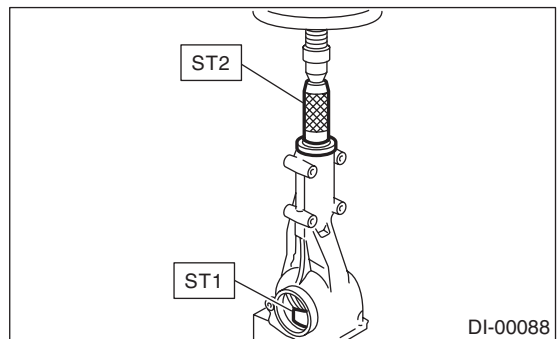

7) Fit a new oil seal with ST.

NOTE:

- Press-fit until the end of oil seal is 1 mm (0.04 in) inward from end of carrier.
- Apply grease between the oil seal lips.

ST 498447120 INSTALLER

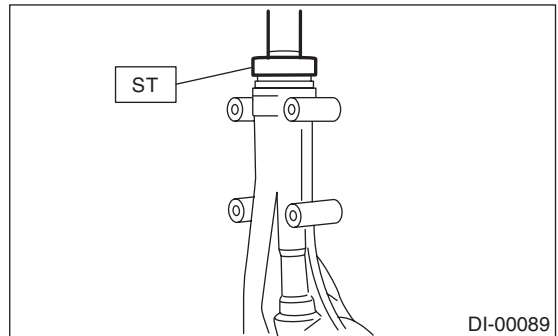

8) Press-fit the companion flange with ST1 and ST2.

NOTE:

Be careful not to damage the bearing.

ST1 899874100 INSTALLER

ST2 399780104 WEIGHT

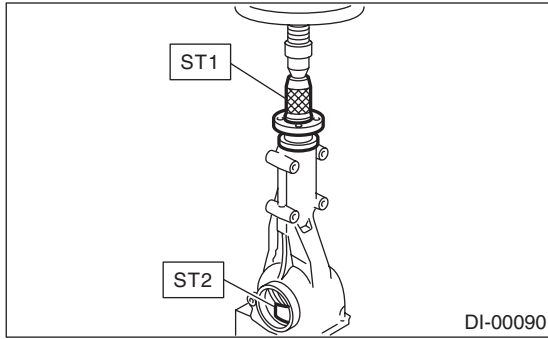

9) Apply Lock Tite to the bolt threads of drive pinion shaft, and the seating surface of new self-locking nut.

Lock Tite:

THREE BOND 1324 (Part No. 004403042)

10) Install a new self-locking nut. Then tighten it with the ST.

ST 498427200 FLANGE WRENCH

Tightening torque:

181.5 N·m (18.5 kgf·m, 134 ft·lb)

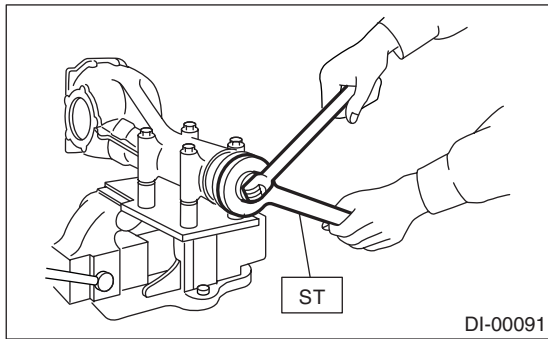

11) Assembling differential case
Install the side gears and pinion mate gears, with their thrust washers and pinion mate shaft, into differential case. (Model without LSD)

NOTE:

- Apply gear oil on both sides of the washer and on the side gear shaft before installing.

- Insert the pinion mate shaft into the differential case by aligning the lock pin holes.

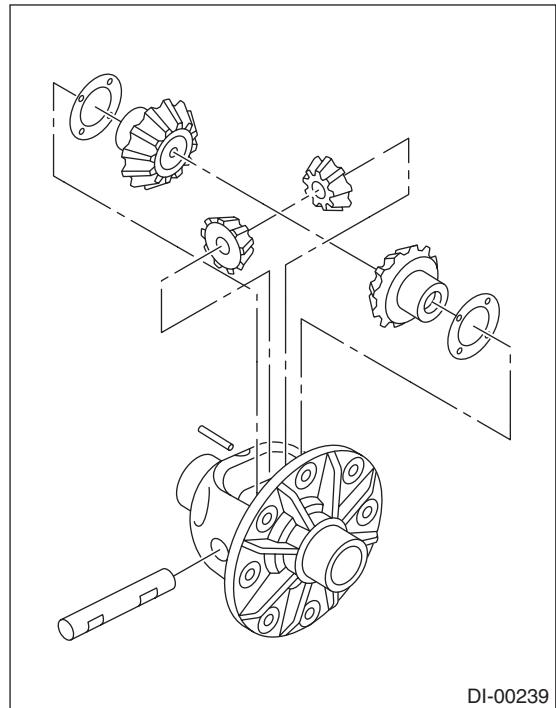

(1) Measure the side gear backlash.

Side gear backlash:

0.10 — 0.20 mm (0.004 — 0.008 in)

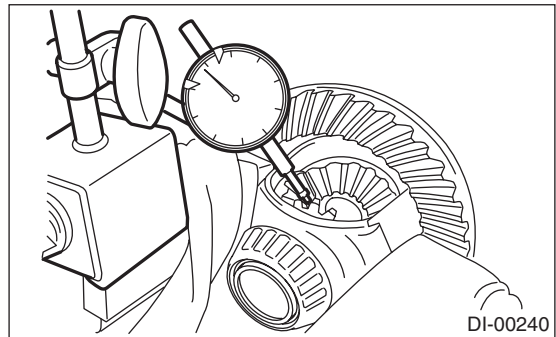

(2) Adjust the backlash as specified by selecting the side gear thrust washer.

Side gear thrust washer	
Part No.	Thickness mm (in)
383445201	0.75 — 0.80 (0.0295 — 0.0315)
383445202	0.80 — 0.85 (0.0315 — 0.0335)
383445203	0.85 — 0.90 (0.0335 — 0.0354)

(3) Check the condition of rotation after applying oil to the gear tooth surfaces and thrust surfaces.

(4) After inserting the pinion shaft lock pin into differential case, stake both sides of the hole to prevent pin from falling off.

12) Install the hypoid driven gear on differential case.

Rear Differential

DIFFERENTIALS

NOTE:

- Before installing the bolts, apply Lock Tite to bolt threads.
- Make sure that there is no clearance between differential case and driven gear.

Lock Tite:

THREE BOND 1324 (Part No. 004403042) or equivalent

NOTE:

Tighten diagonally while tapping the bolt heads.

Tightening torque:

103 N·m (10.5 kgf·m, 76 ft·lb)

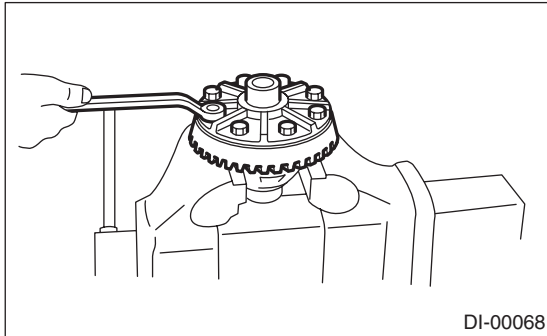

13) Press-fit the side bearing into differential case using ST.

ST 398487700 DRIFT

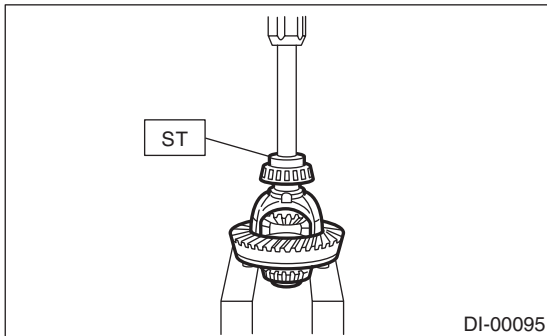

14) Press the side bearing outer race into side bearing retainer using ST.

ST 398417700 DRIFT

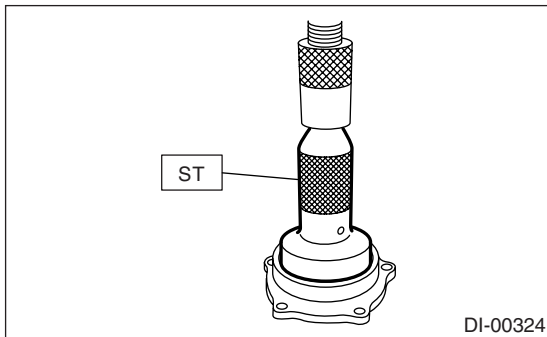

15) Adjusting side bearing retainer shims

(1) The driven gear backlash and side bearing preload can be determined by the side bearing retainer shim thickness.

(2) Install the differential case assembly into differential carrier in the reverse order of disassembly.

NOTE:

Be careful not to hit the teeth against the case.

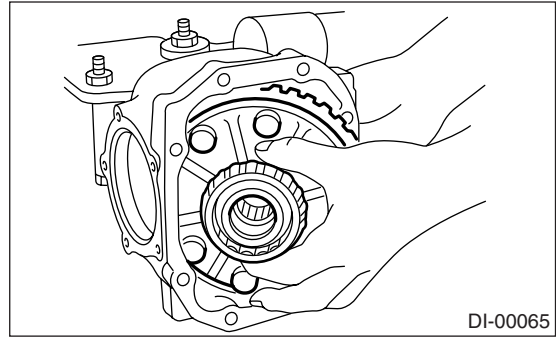

(3) Install the side bearing retainer shims to the right and left retainers from which they were removed.

NOTE:

Replace the broken or corroded side bearing retainer shim with a new one of same thickness.

Side bearing retainer shim	
Part No.	Thickness mm (in)
383475201	0.20 (0.0079)
383475202	0.25 (0.0098)
383475203	0.30 (0.0118)
383475204	0.40 (0.0157)
383475205	0.50 (0.0197)

(4) Align the arrow mark on differential carrier with the mark on side bearing retainer during installation.

NOTE:

Be careful that side bearing outer race is not damaged by bearing roller.

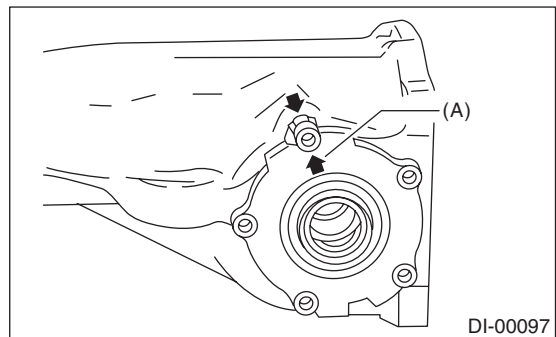

(A) Arrow mark

(5) Tighten the side bearing retainer bolts.

Tightening torque:

10.5 N·m (1.1 kgf·m, 7.7 ft·lb)

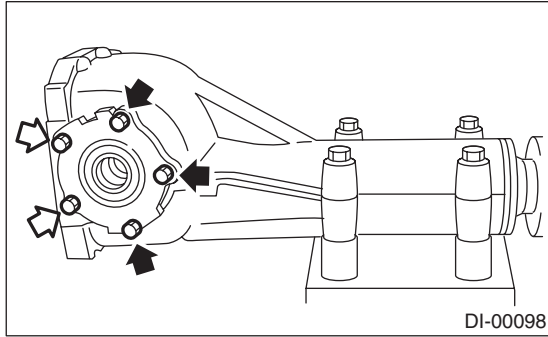

(6) Measure the hypoid driven gear-to-drive pinion backlash. Set the magnet base on differential carrier. Align the contact point of dial gauge with tooth face of hypoid driven gear, and move the hypoid driven gear while holding drive pinion still. Read the value indicated on dial gauge.

Backlash:

0.10 — 0.20 mm (0.004 — 0.008 in)

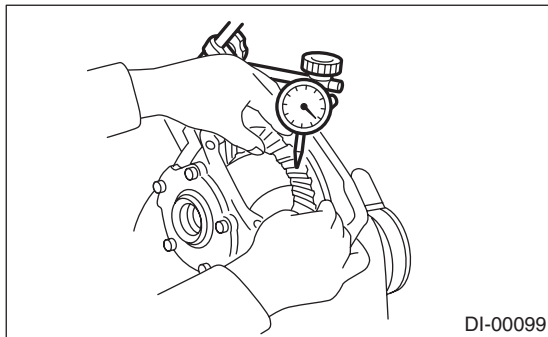

NOTE:

If the backlash exceeds 0.20 mm (0.008 in), reduce the thickness of shim on the back face of hypoid driven gear and increase the thickness of shim on the tooth face of hypoid driven gear. If the backlash is less than 0.10 mm (0.004 in), increase the thickness of shim on the back face of hypoid driven gear and reduce the thickness of shim on the tooth face of hypoid driven gear.

(7) At the same time, measure the total preload of drive pinion. Compared with the resistance when differential case is not installed, if the total preload is not within specification, adjust the thickness of side bearing retainer shims, increasing/reducing by an even amount at a time.

Total preload:

20.7 — 54.4 N (2.1 — 5.5 kgf, 4.7 — 12.2 lbf)

16) Re-check the hypoid driven gear-to-pinion backlash.

Backlash:

0.10 — 0.20 mm (0.004 — 0.008 in)

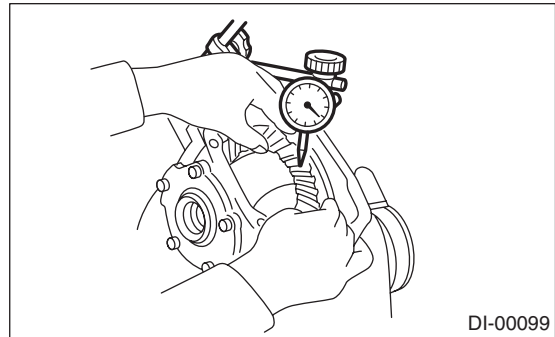

17) Check the hypoid driven gear runout on its back surface, and make sure that pinion and hypoid driven gear rotate smoothly.

Limit of runout:

Less than 0.05 mm (0.0020 in)

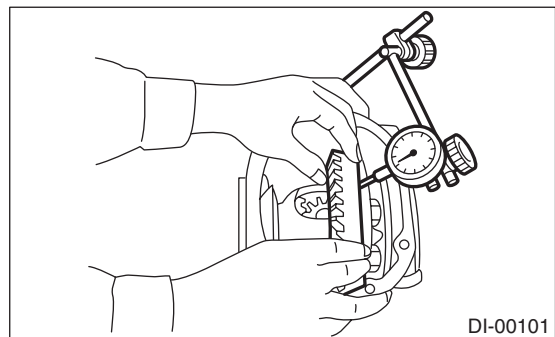

18) Checking and adjusting tooth contact of hypoid driven gear

(1) Apply an even coat of red lead on both sides of three or four teeth on the hypoid driven gear. Check the contact pattern after rotating the hypoid driven gear several revolutions back and forth until a definite contact pattern appears on the hypoid driven gear.

(2) When the contact pattern is incorrect, readjust according to the instructions given in "TOOTH CONTACT PATTERN".

NOTE:

Be sure to wipe off red lead completely after adjustment is completed.

Rear Differential

DIFFERENTIALS

- Correct tooth contact

Checking item: Tooth contact pattern is slightly shifted toward to toe side under no-load rotation. (When loaded, contact pattern moves toward heel)

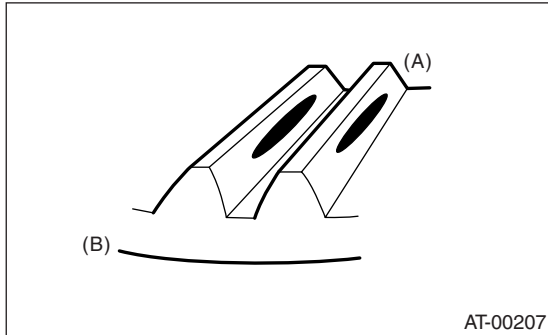

- (A) Toe side
- (B) Heel side

- Face contact

Checking item: Backlash is too large.
Contact pattern

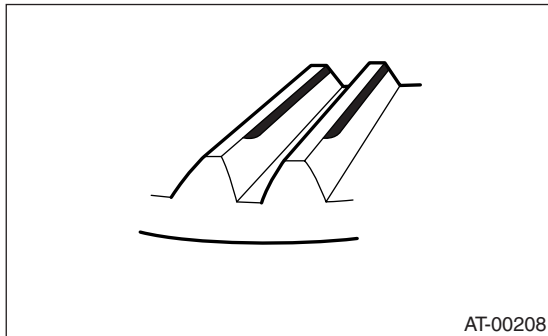

Corrective action: Increase thickness of drive pinion height adjusting washer in order to bring drive pinion close to hypoid driven gear.

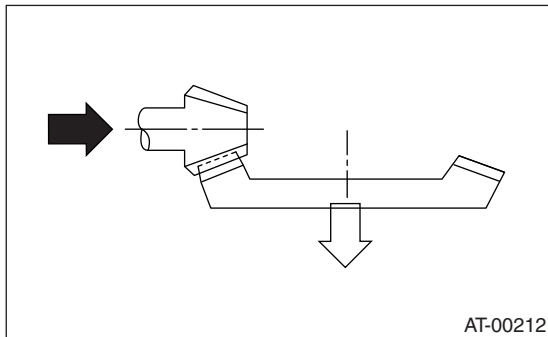

- Flank contact

Checking item: Backlash is too small.
Contact pattern

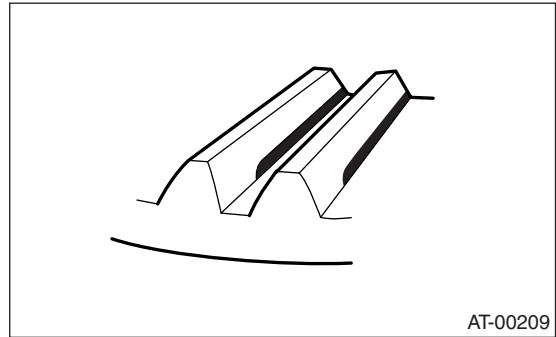

Corrective action: Reduce thickness of drive pinion height adjusting washer in order to move drive pinion away from hypoid driven gear.

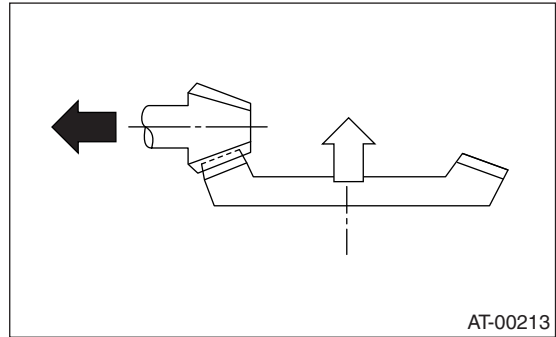

- Toe contact (Inside end contact)
- Checking item: Contact area is small.**
Contact pattern

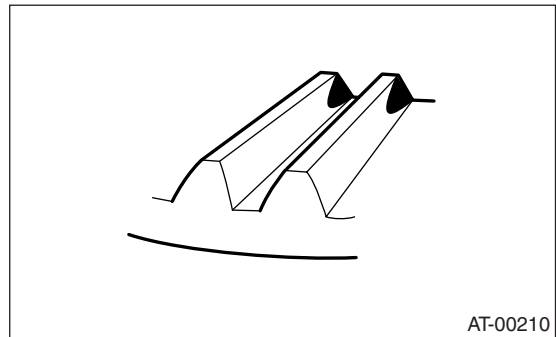

Corrective action: Reduce thickness of drive pinion height adjusting washer in order to move drive pinion away from hypoid driven gear.

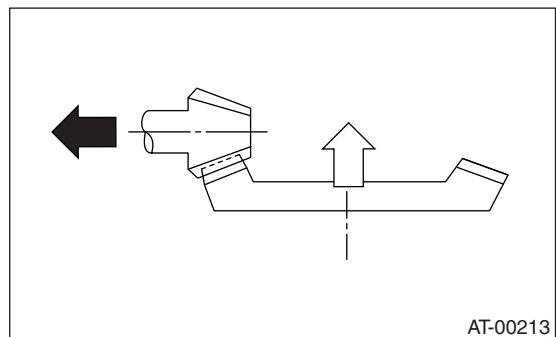

- Heel contact (Outside end contact)

Checking item: Contact area is small.

Contact pattern

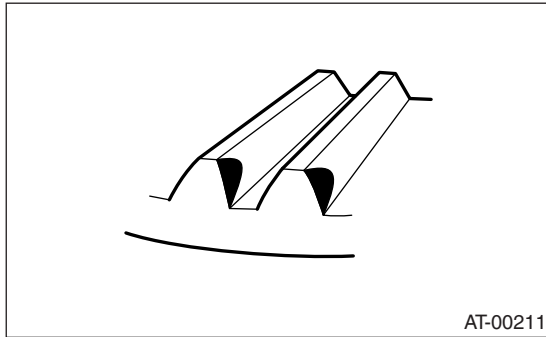

Corrective action: Increase thickness of drive pinion height adjusting washer in order to bring drive pinion close to hypoid driven gear.

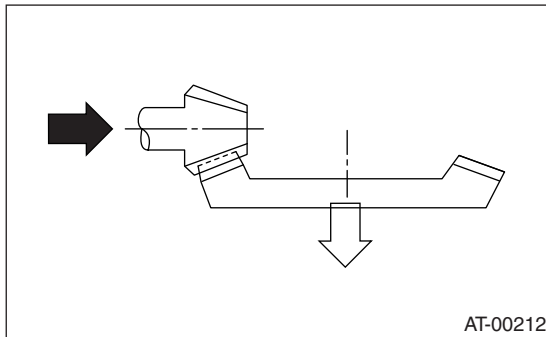

19) If proper tooth contact is not obtained, once again adjust the drive pinion height by changing RH and LH side bearing retainer shims and the hypoid gear backlash.

20) Remove the side bearing retainers on right and left side.

21) Install new O-rings to side bearing retainers on right and left side.

22) Install the oil seals to side bearing retainers on right and left side.

23) Align the arrow mark on differential carrier with the mark on side bearing retainer during installation.

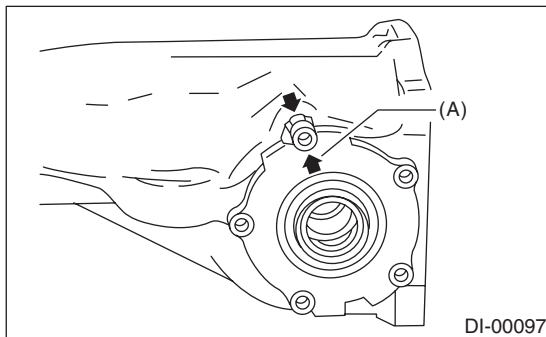

(A) Arrow mark

24) Apply liquid gasket to the bolt with arrow mark, and install the side bearing retainer.

Liquid gasket:

THREE BOND 1105 (Part No. 004403010) or equivalent

Tightening torque:

10.5 N·m (1.1 kgf-m, 7.7 ft-lb)

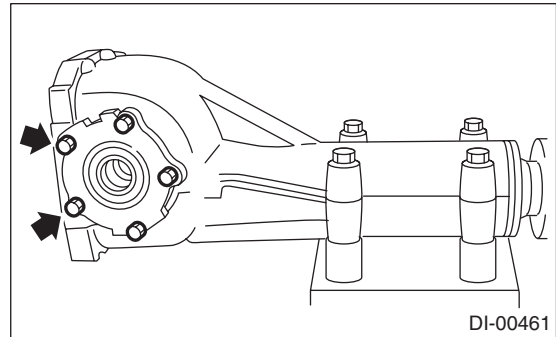

25) Install the new gasket and rear cover and tighten the bolts to specified torque.

Tightening torque:

29.5 N·m (3.0 kgf-m, 21.8 ft-lb)

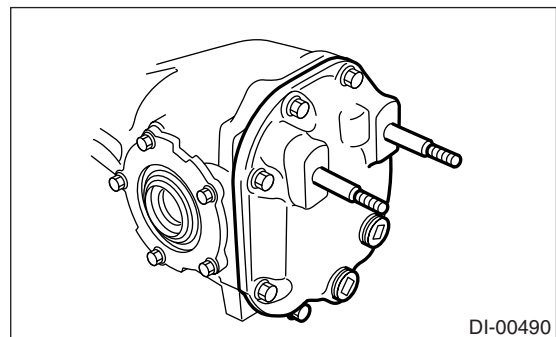

26) Install the air breather cap.

27) Install the drain plug and filler plug.

Tightening torque:

49 N·m (5.0 kgf-m, 36.2 ft-lb)

2. STI MODEL

1) Precautions for assembling

- Assemble in the reverse order of disassembling.
- Check and adjust each part during assembly.
- Keep the shims and washers in order, so that they are not improperly installed.
- Thoroughly clean the surfaces on which the shims, washers and bearings are to be installed.
- Apply gear oil when installing the bearings and thrust washers.
- Be careful not to mix up the right and left hand races of the bearings.

Rear Differential

DIFFERENTIALS

- Replace the oil seal with a new one at every disassembly. Apply chassis grease between the lips when installing the oil seal.

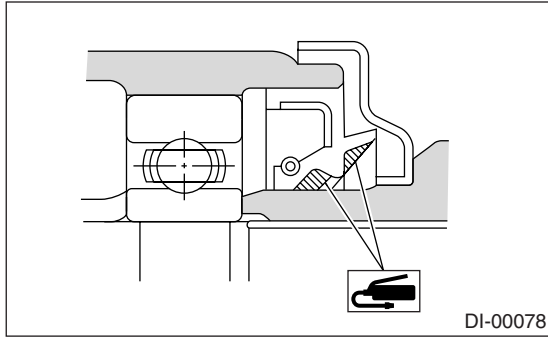

- Adjust the bearing preload with spacer and washer between front and rear bearings. Pinion height adjusting washer are not affected by this adjustment. The adjustment must be carried out without oil seal inserted.

2) Press-fit the rear bearing race into differential carrier using ST.

ST 398417700 DRIFT

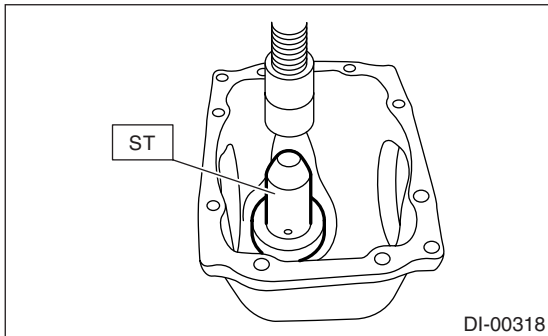

3) Press-fit the front bearing race into differential carrier using ST.

ST 398477702 DRIFT

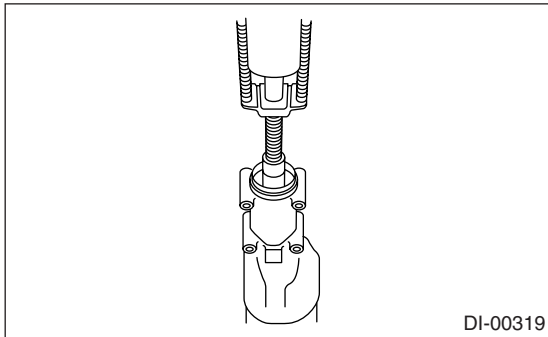

4) Pinion height adjusting washer selection.

(1) Measure the thickness of inserted pinion height adjusting washer.

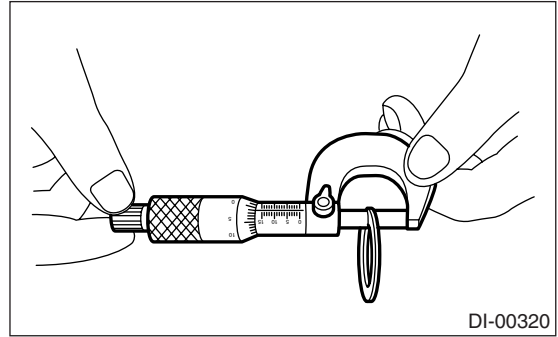

(2) Read the punch mark of installed drive pinion gear and new one.

NOTE:

If there is no punch mark, it means 0 (zero).

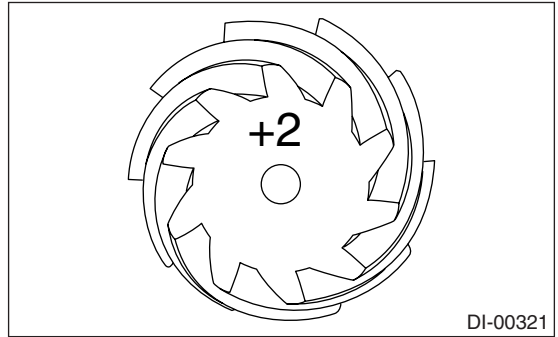

(3) Obtain the thickness of pinion height adjust shim to be inserted from the following formula, and replace the inserted shim with this one.

$$T = T1 + (T2 \times 0.01 - T3 \times 0.01)$$

T mm	Thickness of selected pinion height adjusting washer.
T1 mm	Thickness of inserted pinion height adjusting washer.
T2 mm	Punch mark number on installed drive pinion gear.
T3 mm	Punch mark number on new drive pinion gear.

(Example of calculation)

$$T1 = 3.30, T2 = +2, T3 = -1$$

$$T = 3.30 + \{(2 \times 0.01) - (-1 \times 0.01)\} = 3.33$$

Result: Thickness = 3.33 mm

Therefore use the washer 38336AA310.

Pinion height adjusting washer	
Part No.	Thickness T mm (in)
38336AA230	3.09 (0.1217)
38336AA240	3.12 (0.1228)
38336AA250	3.15 (0.1240)
38336AA260	3.18 (0.1252)
38336AA270	3.21 (0.1264)
38336AA280	3.24 (0.1276)
38336AA290	3.27 (0.1287)
38336AA300	3.30 (0.1299)
38336AA310	3.33 (0.1311)
38336AA320	3.36 (0.1323)
38336AA330	3.39 (0.1335)
38336AA340	3.42 (0.1346)
38336AA350	3.45 (0.1358)
38336AA360	3.48 (0.1370)
38336AA370	3.51 (0.1382)
38336AA380	3.54 (0.1394)
38336AA390	3.57 (0.1406)
38336AA400	3.60 (0.1417)
38336AA410	3.63 (0.1429)
38336AA420	3.66 (0.1441)

5) Install the selected pinion height adjusting washer on drive pinion, and press-fit the rear bearing cone into position with ST.

ST 18674AA000 INSTALLER

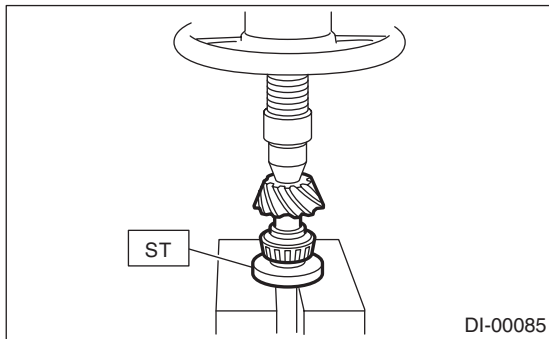

6) Insert the drive pinion into differential carrier, install the previously selected bearing preload adjusting spacer and washer.

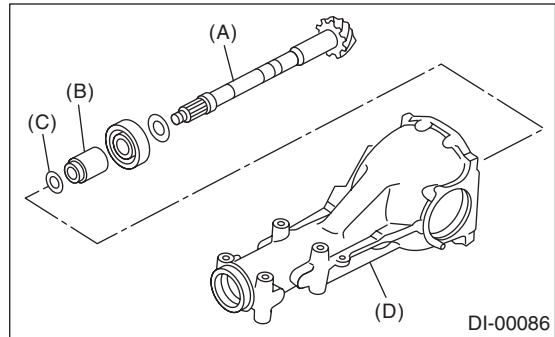

- (A) Drive pinion
- (B) Bearing preload adjusting spacer
- (C) Bearing preload adjusting washer
- (D) Differential carrier

7) Insert the spacer, then press-fit the pilot bearing with STs.

- ST1 399780104 WEIGHT
- ST2 899580100 INSTALLER
- ST3 398507703 DUMMY COLLER
- ST4 498937110 HOLDER

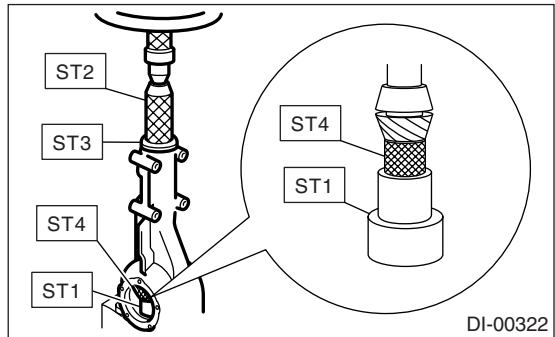

8) Press-fit the companion flange with ST1, ST2 and ST3.

NOTE:

Be careful not to damage the bearing.

- ST1 899874100 INSTALLER
- ST2 399780104 WEIGHT
- ST3 498937110 HOLDER

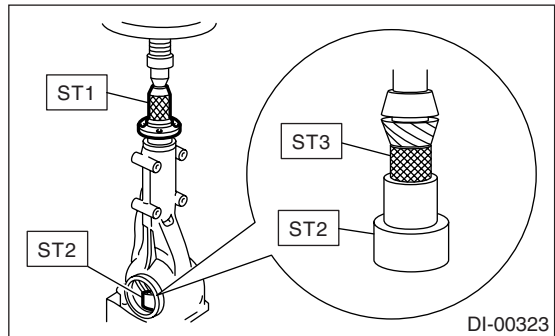

Rear Differential

DIFFERENTIALS

9) Apply Lock Tite to the bolt threads of drive pinion shaft, and the seating surface of new self-locking nut.

Lock Tite:

THREE BOND 1324 (Part No. 004403042)

10) Install the self-locking nut. Then tighten it with the ST.

ST 18633AA000 WRENCH COMPL

Tightening torque:

181.5 N·m (18.5 kgf-m, 134 ft-lb)

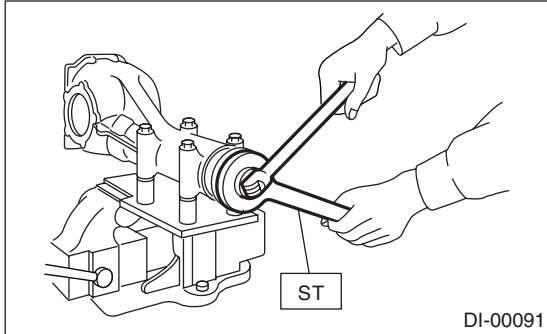

11) Rotate the drive pinion shaft more than ten times to accustom each taper roller bearing, and then measure the preload.

Bearing preload:

24.1 — 38.6 N (2.5 — 3.9 kgf, 5.4 — 8.7 lbf)

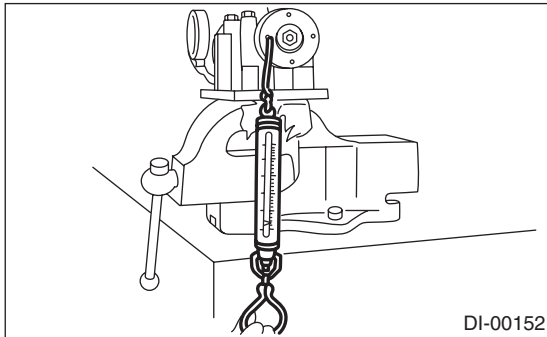

12) If bearing preload is out of specification, adjust to specification by selecting preload adjusting washer and spacer from the following table.

Preload adjusting washer	Part No.	Thickness mm (in)
	383705200	2.59 (0.1020)
	383715200	2.57 (0.1012)
	383725200	2.55 (0.1004)
	383735200	2.53 (0.0996)
	383745200	2.51 (0.0988)
	383755200	2.49 (0.0980)
	383765200	2.47 (0.0972)
	383775200	2.45 (0.0965)
	383785200	2.43 (0.0957)
	383795200	2.41 (0.0949)
	383805200	2.39 (0.0941)
	383815200	2.37 (0.0933)
	383825200	2.35 (0.0925)
383835200	2.33 (0.0917)	
383845200	2.31 (0.0909)	
Preload adjusting spacer	Part No.	Length mm (in)
	31454AA130	52.2 (2.055)
	31454AA140	52.4 (2.063)
	31454AA150	52.6 (2.071)
	31454AA160	52.8 (2.079)
	31454AA170	53.0 (2.087)
	31454AA180	53.2 (2.094)

13) Hold the companion flange with ST and remove the self-locking nut.

ST 18633AA000 WRENCH COMPL

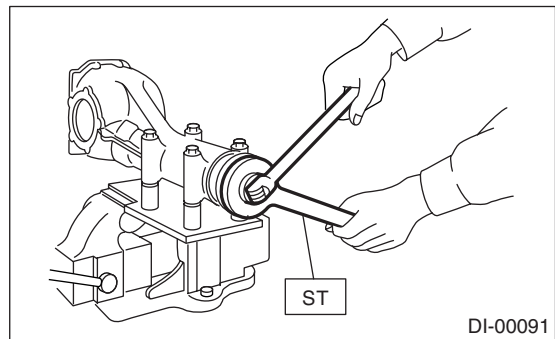

14) Extract the companion flange with a puller.

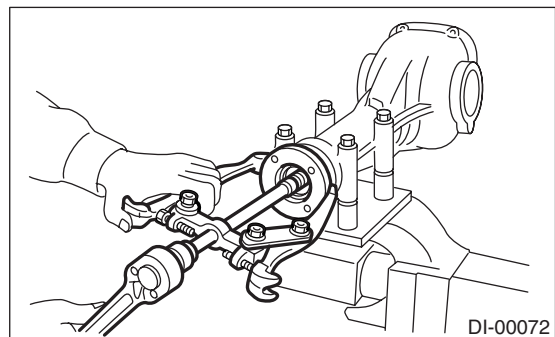

15) Fit a new oil seal with ST.

NOTE:

- Press-fit until the end of oil seal is 1 mm (0.04 in) inward from end of carrier.
- Apply grease between the oil seal lips.

ST 498447120 INSTALLER

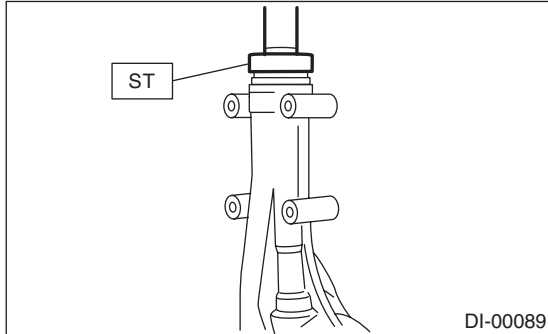

16) Press-fit the companion flange with ST1, ST2 and ST3.

ST1 899874100 INSTALLER
 ST2 399780104 WEIGHT
 ST3 498937110 HOLDER

NOTE:

Be careful not to damage the bearing.

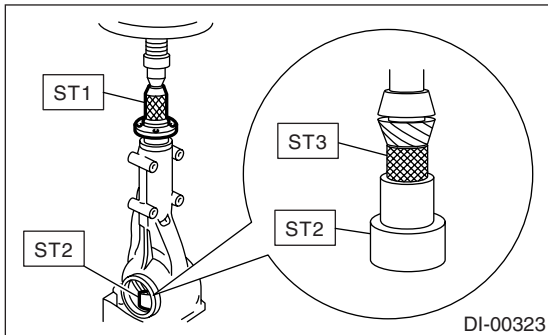

17) Apply Lock Tite to the bolt threads of drive pinion shaft, and the seating surface of new self-locking nut.

Lock Tite:

THREE BOND 1324 (Part No. 004403042)

18) Install the self-locking nut. Then tighten it with the ST.

ST 18633AA000 WRENCH COMPL

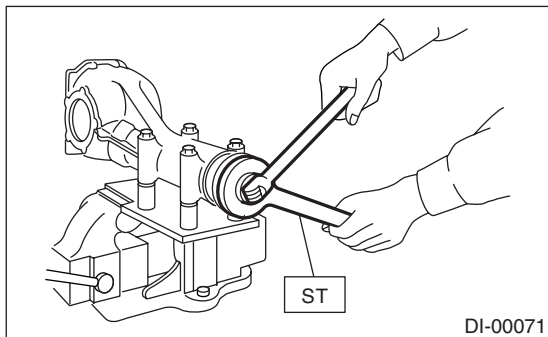

19) Install the hypoid driven gear on differential case.

NOTE:

- Before installing the bolts, apply Lock Tite to bolt threads.
- Make sure that there is no clearance between differential case and driven gear.

Lock Tite:

THREE BOND 1324 (Part No. 004403042) or equivalent

NOTE:

Tighten diagonally while tapping the bolt heads.

Tightening torque:

103 N·m (10.5 kgf-m, 76 ft-lb)

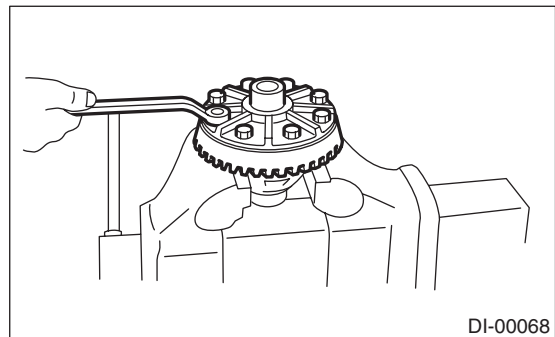

20) Press-fit the side bearing onto differential case with ST.

ST 398487700 DRIFT

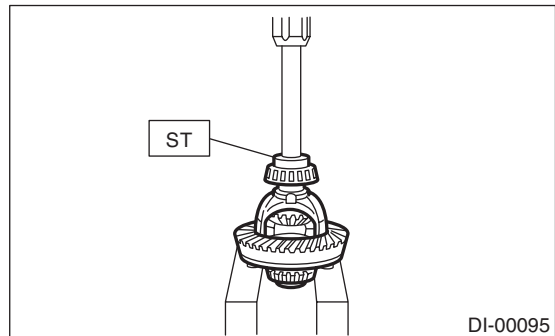

21) Assembling side bearing retainer.

(1) Press-fit the side bearing outer race with press and ST.

ST 398417700 DRIFT

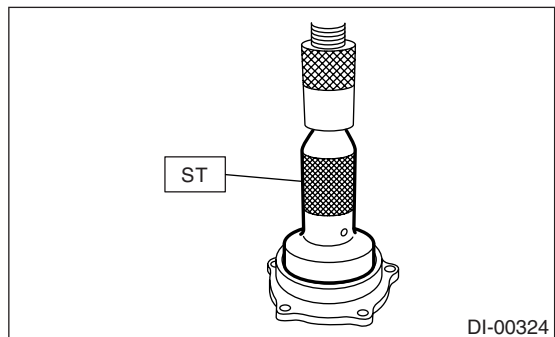

Rear Differential

DIFFERENTIALS

(2) Install the oil seal. <Ref. to DI-50, REPLACEMENT, Rear Differential Side Oil Seal.>

22) Adjusting side bearing retainer shims

(1) The driven gear backlash and side bearing preload can be determined by the side bearing retainer shim thickness.

(2) Install the differential case assembly into differential carrier in the reverse order of disassembly.

NOTE:

Be careful not to hit the teeth against the case.

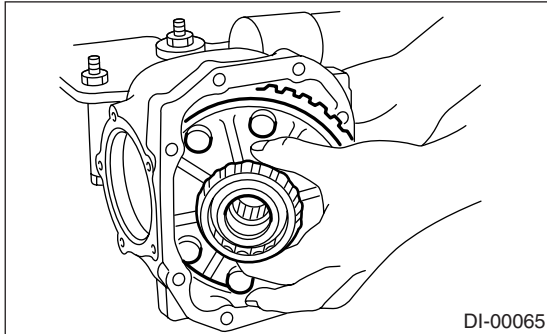

(3) Install the side bearing retainer shims to the right and left retainers from which they were removed.

NOTE:

Replace the broken or corroded side bearing retainer shim with a new one of same thickness.

Side bearing retainer shim	
Part No.	Thickness mm (in)
383475201	0.20 (0.0079)
383475202	0.25 (0.0098)
383475203	0.30 (0.0118)
383475204	0.40 (0.0157)
383475205	0.50 (0.0197)

(4) Align the arrow mark on differential carrier with the mark on side bearing retainer during installation.

NOTE:

Be careful that side bearing outer race is not damaged by bearing roller.

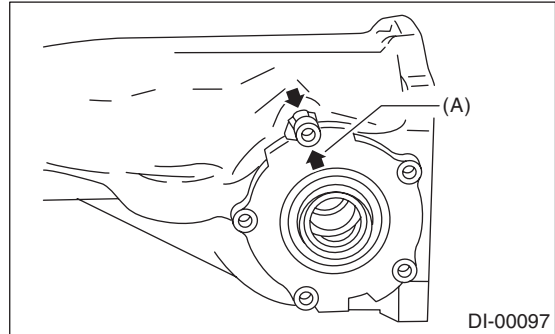

(A) Arrow mark

(5) Tighten the side bearing retainer bolts.

Tightening torque:

10.5 N·m (1.1 kgf·m, 7.7 ft·lb)

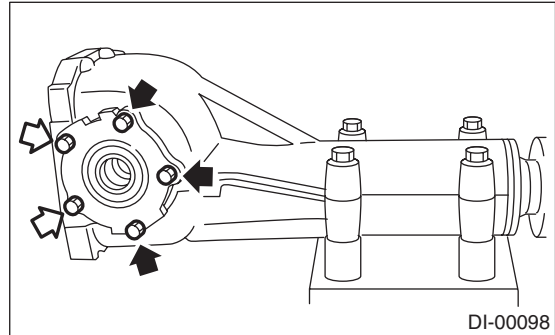

(6) Measure the hypoid driven gear-to-drive pinion backlash. Set the magnet base on differential carrier. Align the contact point of dial gauge with tooth face of hypoid driven gear, and move the hypoid driven gear while holding drive pinion still. Read the value indicated on dial gauge.

Backlash:

0.10 — 0.20 mm (0.004 — 0.008 in)

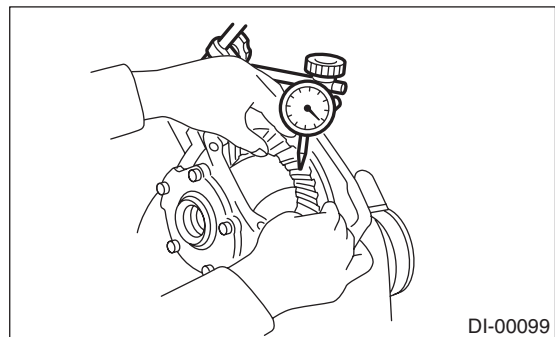

NOTE:

If the backlash exceeds 0.20 mm (0.008 in), reduce the thickness of shim on the back face of hypoid driven gear and increase the thickness of shim on the tooth face of hypoid driven gear. If the backlash is less than 0.10 mm (0.004 in), increase the thickness of shim on the back face of hypoid driven gear and reduce the thickness of shim on the tooth face of hypoid driven gear.

(7) At the same time, measure the total preload of drive pinion. Compared with the resistance when differential case is not installed, if the total preload is not within the specified range, readjust side bearing retainer shims, increasing/reducing by an even amount at a time.

Total preload:

27 — 54 N (2.8 — 5.50 kgf, 6.1 — 12.2 lbf)

23) Re-check the hypoid driven gear-to-pinion backlash.

Backlash:

0.10 — 0.20 mm (0.004 — 0.008 in)

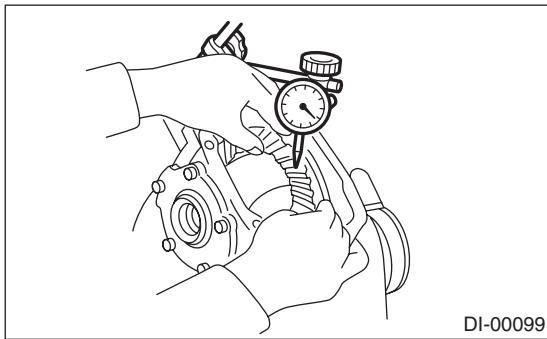

24) Check the hypoid driven gear runout on its back surface, and make sure that pinion and hypoid driven gear rotate smoothly.

Limit of runout:

Less than 0.05 mm (0.0020 in)

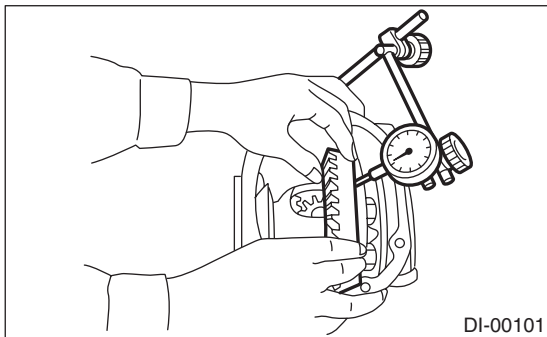

25) Checking and adjusting tooth contact of hypoid driven gear

(1) Apply an even coat of red lead on both sides of three or four teeth on the hypoid driven gear. Check the contact pattern after rotating the hypoid driven gear several revolutions back and forth until a definite contact pattern appears on the hypoid driven gear.

(2) When the contact pattern is incorrect, readjust according to the instructions given in "TOOTH CONTACT PATTERN".

NOTE:

Be sure to wipe off red lead completely after adjustment is completed.

- Correct tooth contact

Checking item: Tooth contact pattern is slightly shifted toward to toe side under no-load rotation. (When loaded, contact pattern moves toward heel)

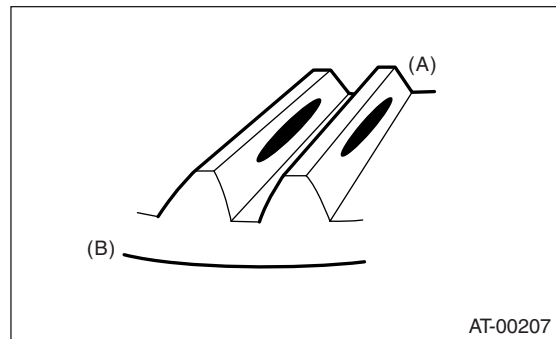

- (A) Toe side
- (B) Heel side

- Face contact

Checking item: Backlash is too large. Contact pattern

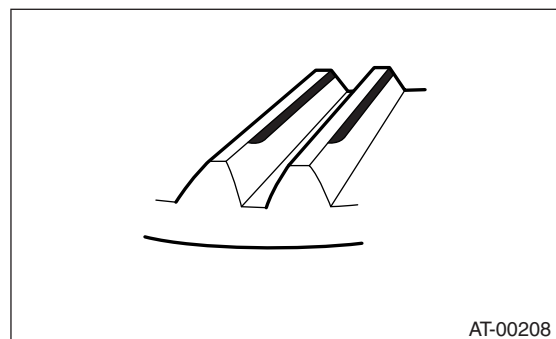

Rear Differential

DIFFERENTIALS

Corrective action: Increase thickness of drive pinion height adjusting washer in order to bring drive pinion close to hypoid driven gear.

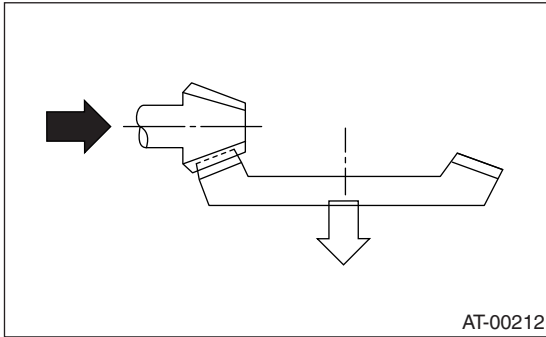

- Flank contact

Checking item: Backlash is too small.
Contact pattern

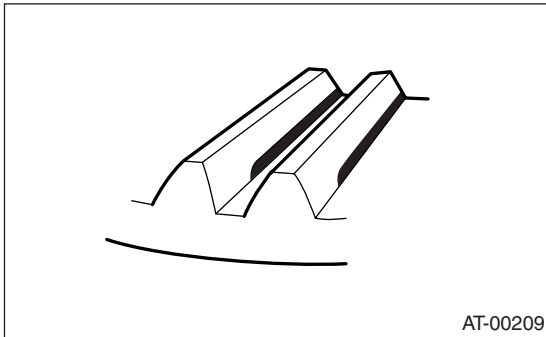

Corrective action: Reduce thickness of drive pinion height adjusting washer in order to move drive pinion away from hypoid driven gear.

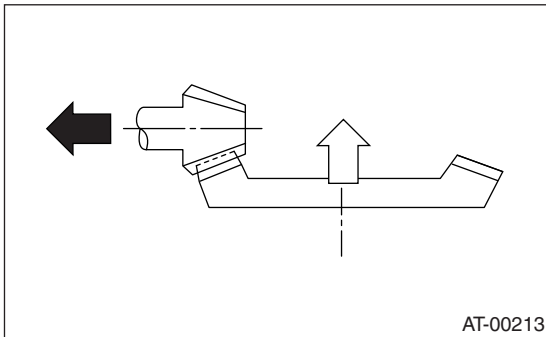

- Toe contact (Inside end contact)

Checking item: Contact area is small.
Contact pattern

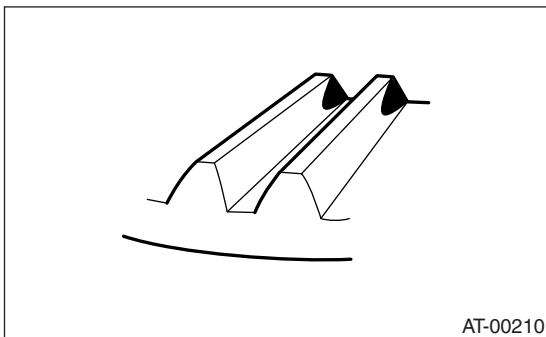

Corrective action: Reduce thickness of drive pinion height adjusting washer in order to move drive pinion away from hypoid driven gear.

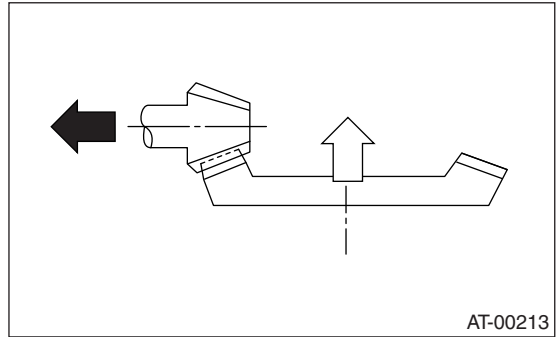

- Heel contact (Outside end contact)

Checking item: Contact area is small.
Contact pattern

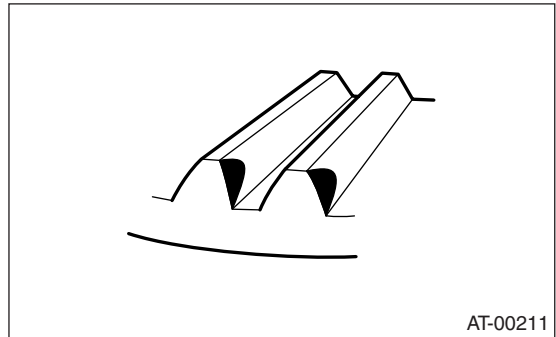

Corrective action: Increase thickness of drive pinion height adjusting washer in order to bring drive pinion close to hypoid driven gear.

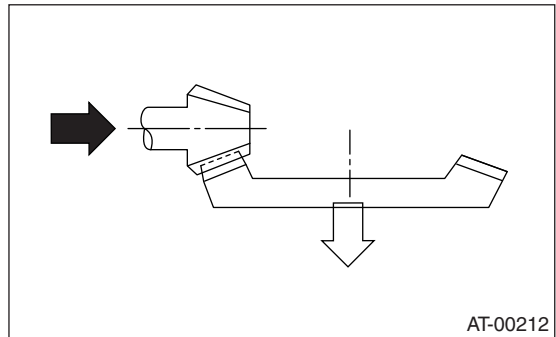

26) If proper tooth contact is not obtained, once again adjust the drive pinion height by changing RH and LH side bearing retainer shims and the hypoid gear backlash.

27) Remove the side bearing retainers on right and left side.

28) Install new O-rings to side bearing retainers on right and left side.

29) Align the arrow mark on differential carrier with the mark on side bearing retainer during installation.

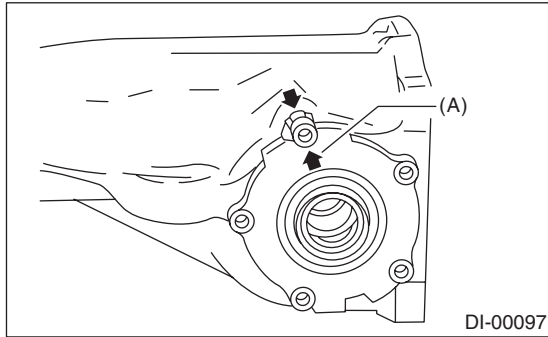

(A) Arrow mark

30) Apply liquid gasket to the bolt with arrow mark, and install the side bearing retainer.

Liquid gasket:

THREE BOND 1105 (Part No. 004403010) or equivalent

Tightening torque:

10.5 N-m (1.1 kgf-m, 7.7 ft-lb)

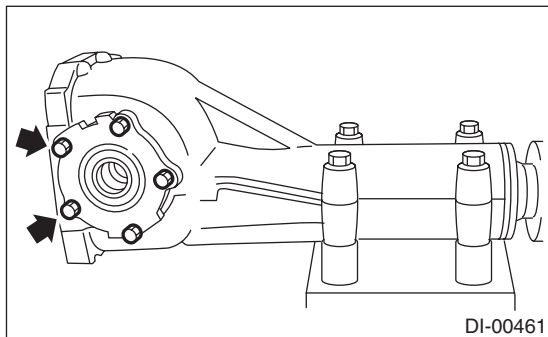

31) Install the new gasket, rear cover and stay ground and tighten the bolts to specified torque.

Tightening torque:

44 N-m (4.5 kgf-m, 32.5 ft-lb)

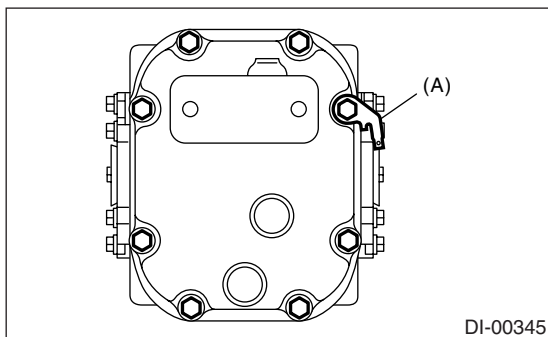

(A) Stay ground

32) Install the new air breather cap.

33) Install the drain plug and rear differential oil temperature switch or oil temperature sensor.

Tightening torque:

49 N-m (5.0 kgf-m, 36.2 ft-lb)

E: INSPECTION

Wash all the disassembled parts clean, and examine them for wear, damage, or other defects. Repair or replace defective parts as necessary.

- 1) Hypoid driven gear and drive pinion
 - If abnormal tooth contact is evident, find out the cause and adjust to give correct tooth contact at assembly. Replace the gear if excessively worn or incapable of adjustment.
 - If crack, score, or seizure is evident, replace as a set. Slight damage of tooth can be corrected by oil stone or the like.
- 2) Side gear and pinion mate gear
 - Replace if crack, score, or other defects are evident on tooth surface.
 - Replace if thrust washer contacting surface is worn or seized. Slight damage of the surface can be corrected by oil stone or the like.
- 3) Bearing

Replace if seizure, peeling, wear, rust, dragging during rotation, abnormal noise or other defect is evident.
- 4) Thrust washers of side gear and pinion mate gear

Replace if seizure, flaw, abnormal wear or other defect is evident.
- 5) Oil seal

Replace if deformed or damaged, and at every disassembling.
- 6) Differential carrier

Replace if the bearing bores are worn or damaged.
- 7) Differential case

Replace if its sliding surfaces are worn or cracked.
- 8) Companion flange

Replace if the oil seal lip contacting surfaces have flaws.
- 9) Rear differential oil temperature switch

If the results of the following inspections are not satisfactory, replace rear differential temperature switch.

 - (1) At room temperature, check for continuity between the sensor terminal and body.
 - (2) Soak the sensor in oil, then raise the oil temperature. Check that the continuity is cut off when the oil temperature is between 144°C (291°F) and 156°C (313°F). Then, check that the continuity resumes by the time the oil temperature drops to 135°C (275°F).

Rear Differential

DIFFERENTIALS

1. SIDE GEAR BACKLASH

Using a dial gauge, check the backlash of the side gear.

Side gear backlash:

0.1 — 0.2 mm (0.004 — 0.008 in)

If the side gear backlash is not within the specification, adjust clearance as specified by selecting the side gear thrust washer.

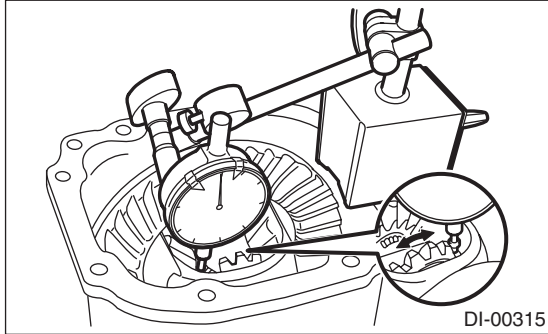

2. HYPOID DRIVEN GEAR BACKLASH

Using a dial gauge, check the backlash of the hypoid driven gear.

Hypoid driven gear backlash:

0.1 — 0.2 mm (0.004 — 0.008 in)

If the hypoid driven gear backlash is not within the specification, adjust the side bearing preload or repair if necessary.

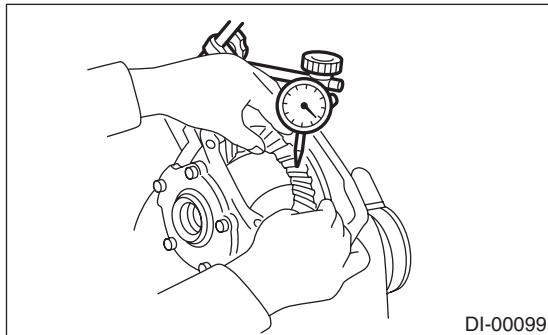

3. HYPOID DRIVEN GEAR RUNOUT

Using a dial gauge, check the hypoid driven gear runout.

Hypoid driven gear runout:

Less than 0.05 mm (0.0020 in)

If the hypoid driven gear runout exceeds 0.05 mm (0.0020 in), replace the hypoid driven gear.

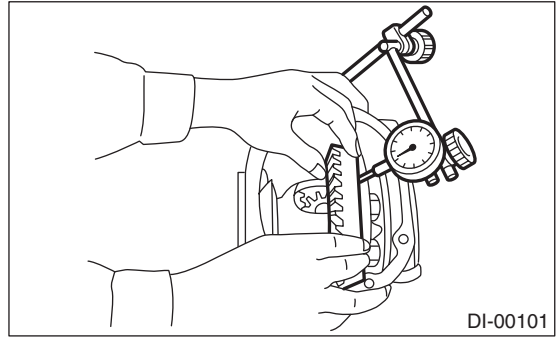

4. TOOTH CONTACT BETWEEN HYPOID DRIVEN GEAR AND DRIVE PINION

Inspect the tooth contact between hypoid driven gear and driven pinion. <Ref. to DI-29, ASSEMBLY, Rear Differential.>

5. TOTAL PRELOAD

Using a gauge, check the turning resistance increase.

Total preload:

Except STI model:

20.7 — 54.4 N (2.1 — 5.5 kgf, 4.7 — 12.2 lbf)

STI model:

27 — 54 N (2.8 — 5.50 kgf, 6.1 — 12.2 lbf)

If the total preload is not within the specification, adjust the side bearing retainer shims.

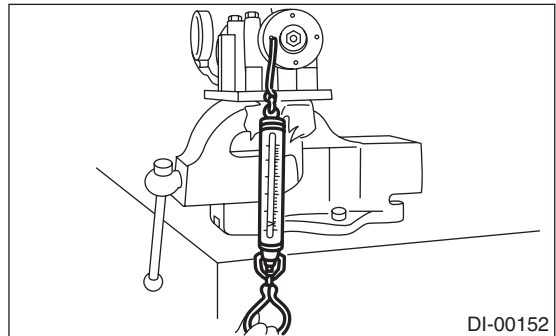

6. COMPANION FLANGE

- 1) If rust or dirt is attached to the companion flange, remove them.
- 2) Set a dial gauge at a companion flange surface (mating surface of propeller shaft and companion flange), and then measure the companion flange runout.

Limit of runout:
0.08 mm (0.003 in)

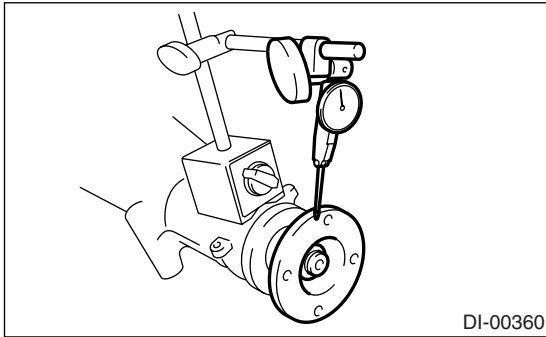

- 3) Set the gauge inside of the companion flange, and measure the runout.

Limit of runout:
0.08 mm (0.003 in)

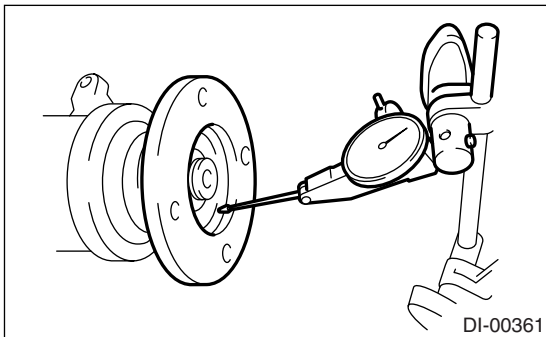

- 4) If either runout exceeds the limit, move the phase of companion flange and drive pinion 90° each, and find the point where the runout is within the limit.
- 5) If the runout exceeds the limit after changing the phase, replace the companion flange and recheck the runout.
- 6) If the runout exceeds the limit after replacing the companion flange, the drive pinion may be assembled incorrectly or bearing is faulty.

F: ADJUSTMENT

1. SIDE GEAR BACKLASH

Adjust the side gear backlash. <Ref. to DI-29, ASSEMBLY, Rear Differential.>

2. HYPOID DRIVEN GEAR BACKLASH

Adjust the hypoid driven gear backlash. <Ref. to DI-29, ASSEMBLY, Rear Differential.>

3. TOOTH CONTACT BETWEEN HYPOID DRIVEN GEAR AND DRIVE PINION

Adjust the tooth contact between hypoid driven gear and drive pinion gear. <Ref. to DI-29, ASSEMBLY, Rear Differential.>

4. TOTAL PRELOAD

Adjust the side bearing shim. <Ref. to DI-29, ASSEMBLY, Rear Differential.>

5. Rear Differential Front Oil Seal

A: REPLACEMENT

- 1) Set the vehicle on a lift.
- 2) Disconnect the ground cable from battery.
- 3) Move the select lever or gear shift lever to "N".
- 4) Release the parking brake.
- 5) Remove the oil drain plug, and drain the gear oil.

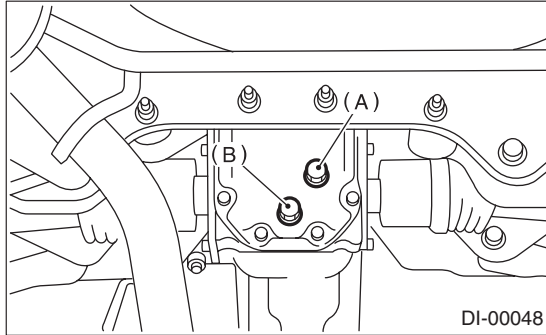

- (A) Filler plug
(B) Drain plug

- 6) Install the oil drain plug.

NOTE:

Apply liquid gasket to the drain plug.

Liquid gasket:

THREE BOND 1105 (Part No. 004403010) or equivalent.

Tightening torque:

49 N·m (5.0 kgf-m, 36.2 ft-lb)

- 7) Lift-up the vehicle.
- 8) Remove the rear exhaust pipe and muffler.
- 9) Remove the propeller shaft from body. <Ref. to DS-16, REMOVAL, Propeller Shaft.>
- 10) Remove the self-locking nut while holding the companion flange with ST.

Except STI model

ST 498427200 FLANGE WRENCH

STI model

ST 18633AA000 WRENCH COMPL

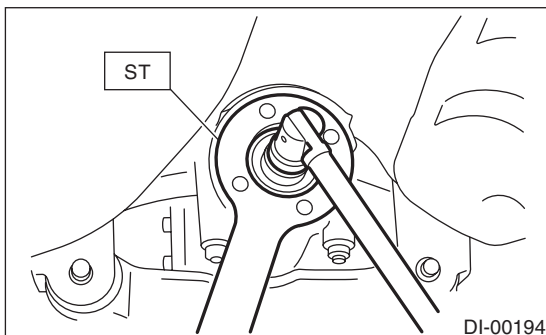

- 11) Remove the center heat shield cover.

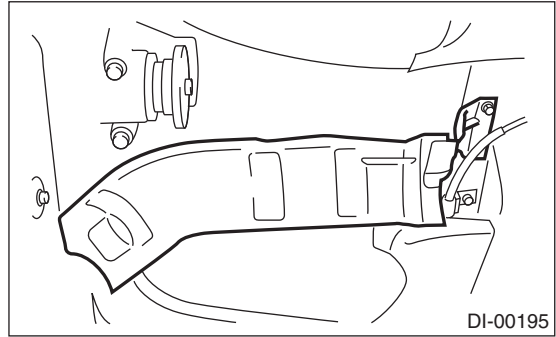

- 12) Extract the companion flange using ST.

ST 399703600 PULLER ASSY

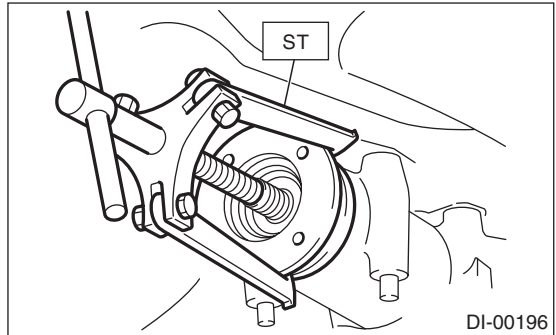

- 13) Remove the oil seal using ST.

ST 398527700 PULLER ASSY

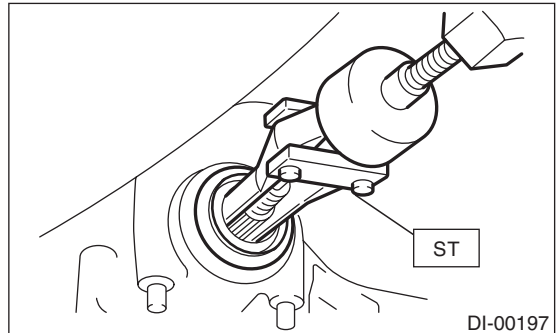

- 14) Fit a new oil seal using ST.

ST 498447120 INSTALLER

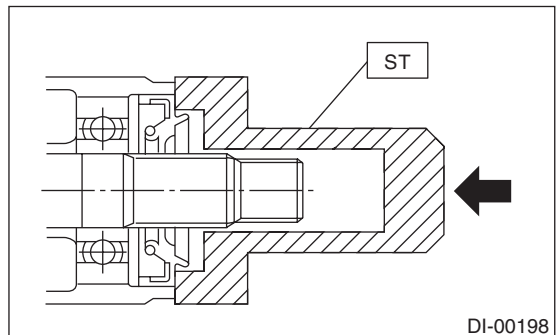

- 15) Install the companion flange.

NOTE:

Use a plastic hammer to install the companion flange.

16) Apply Lock Tite to the bolt threads of drive pinion shaft, and the seating surface of new self-locking nut.

Lock Tite:

THREE BOND 1324 (Part No. 004403042)

17) Tighten the self-locking nut within the specified torque range so that the preload of companion flange becomes the same as that before replacing oil seal.

Except STI model

ST 498427200 FLANGE WRENCH

STI model

ST 18633AA000 WRENCH COMPL

NOTE:

Use a new self-locking nut.

Tightening torque:

181.5 N·m (18.5 kgf-m, 134 ft-lb)

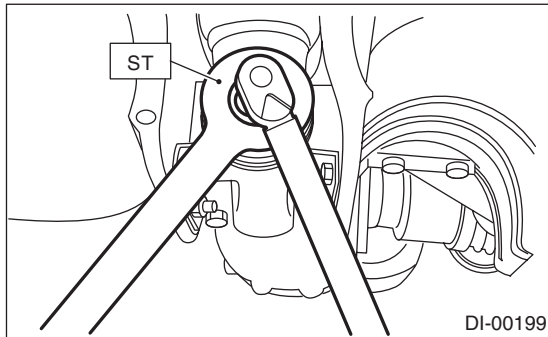

18) Hereafter, reassemble in the reverse order of disassembly.

19) Fill the differential carrier with gear oil to the bottom of filler plug hole after installing. <Ref. to DI-18, Differential Gear Oil.>

Rear Differential Side Oil Seal

DIFFERENTIALS

6. Rear Differential Side Oil Seal

A: INSPECTION

Make sure that there is no oil leakage from side oil seal.

If there is any oil leakage, replace the oil seal.

B: REPLACEMENT

- 1) Move the select lever or gear shift lever to "N".
- 2) Release the parking brake.
- 3) Loosen both wheel nuts.
- 4) Lift-up the vehicle.
- 5) Remove the wheels.
- 6) Remove the rear exhaust pipe and muffler.

- Non-turbo model

<Ref. to EX(H4SO)-7, REMOVAL, Rear Exhaust Pipe.> <Ref. to EX(H4SO)-8, REMOVAL, Muffler.>

- Turbo model and STI model

<Ref. to EX(H4DOTC)-15, REMOVAL, Rear Exhaust Pipe.> <Ref. to EX(H4DOTC)-16, REMOVAL, Muffler.>

- 7) Remove the DOJ of rear drive shaft from rear differential.

- (1) Remove the ABS wheel speed sensor cable clamp and parking brake cable clamp from bracket.

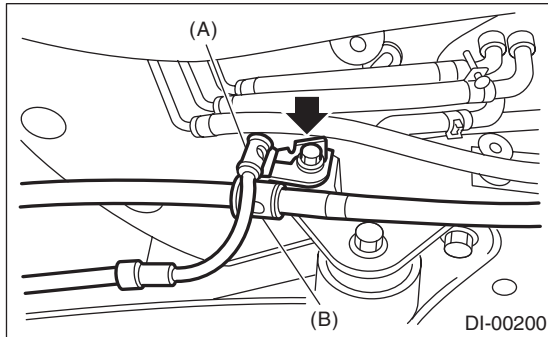

- (A) ABS wheel speed sensor cable clamp
- (B) Parking brake cable clamp

- (2) Remove the ABS wheel speed sensor cable clamp from trailing link.

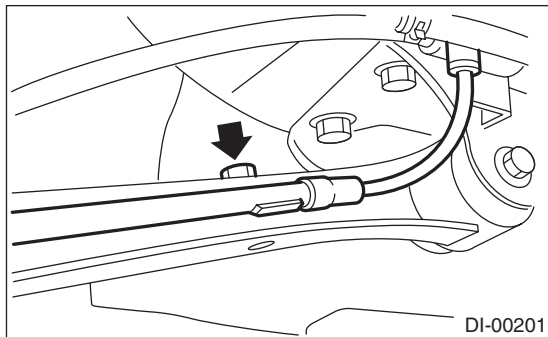

- (3) Remove the ABS wheel speed sensor cable clamp and parking brake cable guide from trailing link.

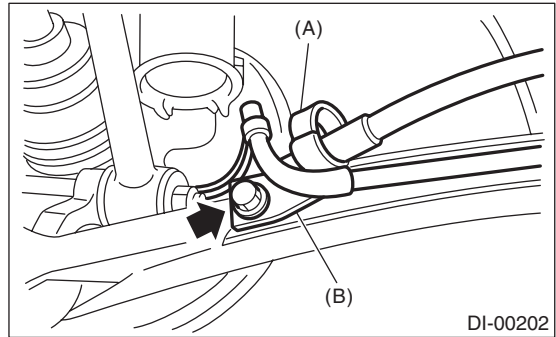

- (A) Parking brake cable guide
- (B) ABS wheel speed sensor cable clamp

- (4) Remove the rear stabilizer link.

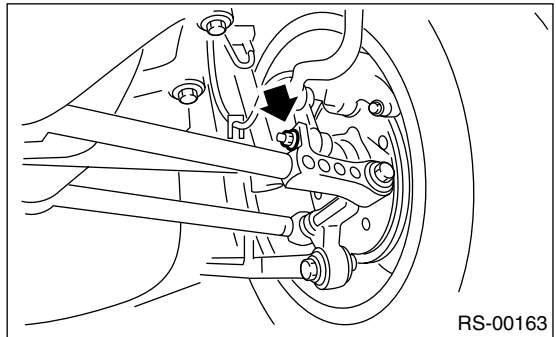

- (5) Remove the bolts which secure trailing link to housing.

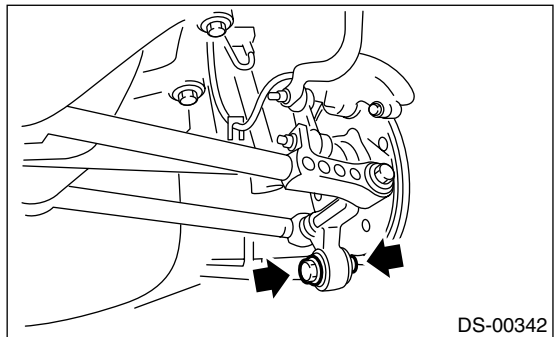

- (6) Remove the bolts which secure the front and rear lateral link to rear housing.

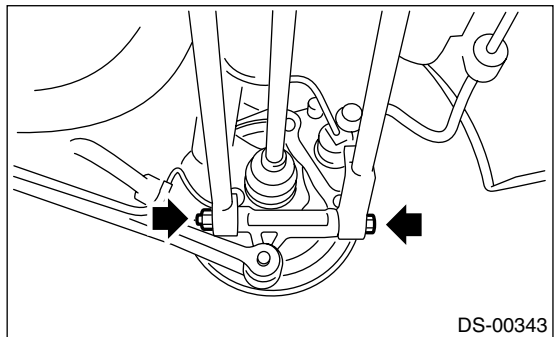

(7) Remove the DOJ from the rear differential by using ST.

NOTE:

When removing the DOJ from rear differential, fit ST to the bolts as shown in the figure so as not to damage the side bearing retainer.

ST 208099PA100 DRIVE SHAFT REMOVER

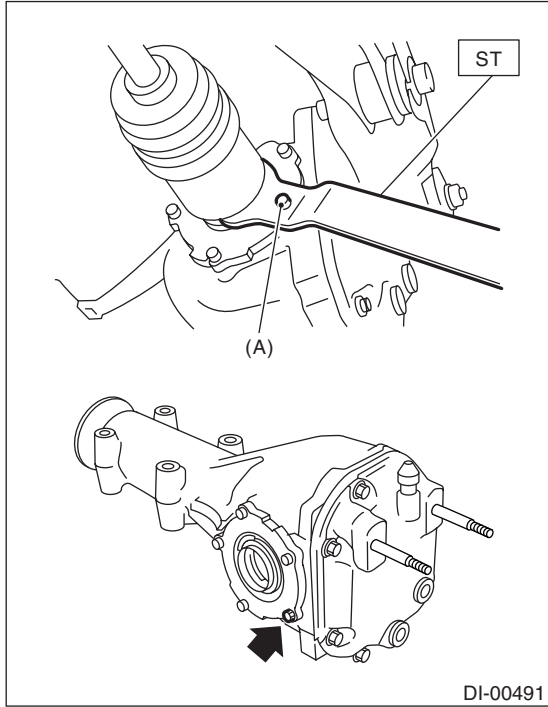

(A) Bolt

8) Suspend the rear drive shaft to the rear cross-member using wire.

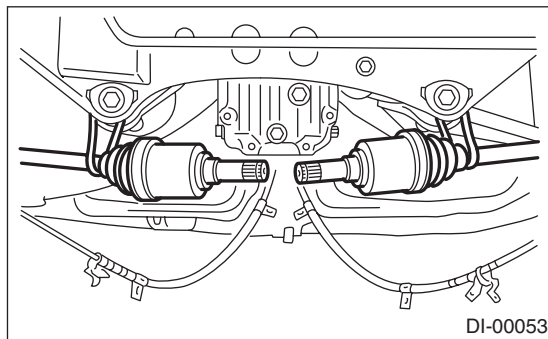

9) Remove the oil seal using ST.

ST 398527700 PULLER ASSY

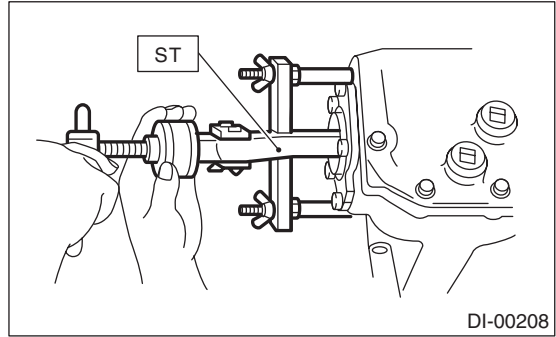

10) Drive in a new side oil seal using ST.

NOTE:

Apply chassis grease between the oil seal lips.

ST 398437700 DRIFT

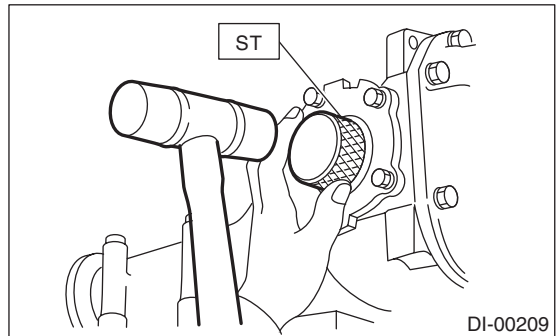

11) Insert the DOJ into rear differential.

(1) Install the ST to rear differential.

ST 28099PA090 OIL SEAL PROTECTOR

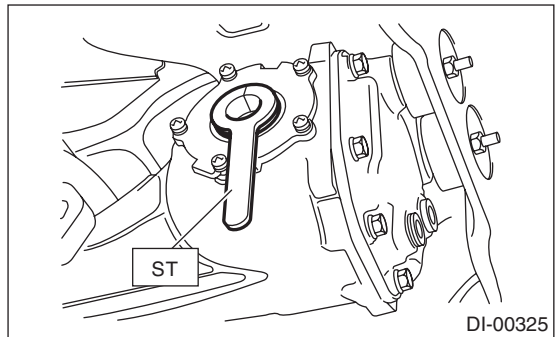

(2) Install the spline shaft until the spline portion is inside the side oil seal using ST.

ST 28099PA090 OIL SEAL PROTECTOR

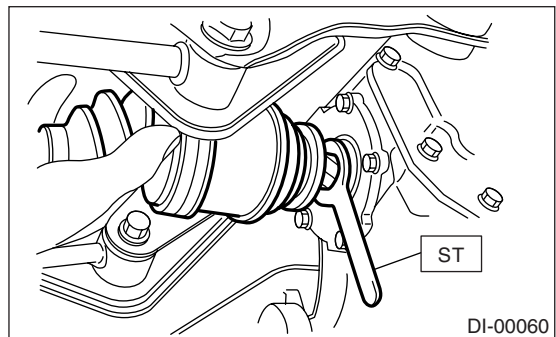

Rear Differential Side Oil Seal

DIFFERENTIALS

(3) Remove the ST.

ST 28099PA090 OIL SEAL PROTECTOR

12) Hereafter, reassemble in the reverse order of disassembly.

7. Rear Differential Member

A: REMOVAL

When removing the differential front member, work the removal procedure as rear differential.

<Ref. to DI-21, REMOVAL, Rear Differential.>

B: INSTALLATION

1) Position the differential front member on body by passing it under the parking brake cable and securing to rear differential.

NOTE:

When installing the differential front member, do not confuse the installation sequence of the stopper.

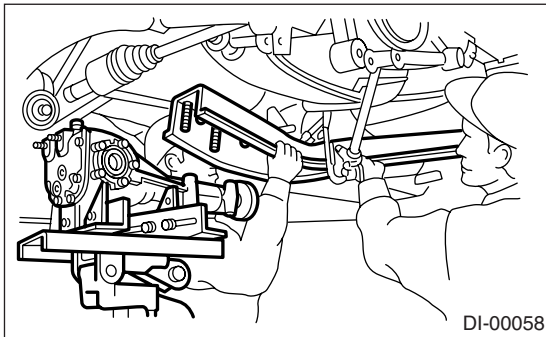

2) Insert the DOJ of rear drive shaft into rear differential. <Ref. to DI-50, REPLACEMENT, Rear Differential Side Oil Seal.>

NOTE:

Before inserting, replace the differential side oil seal with a new one.

ST 28099PA090 OIL SEAL PROTECTOR

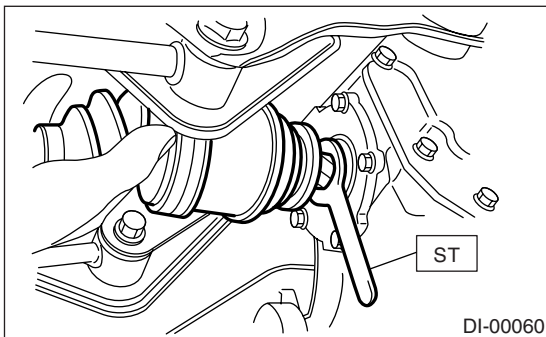

3) Hereafter, install in the reverse order of removal.

C: INSPECTION

1) Check the rear differential member for damage, bend, or corrosion.

If damage, bend, or corrosion is excessive, replace the rear differential member.

2) Check the bushings of rear differential member for cracking, hardening, or damage.

If cracking, hardening, or damage is excessive, replace the rear differential member.

General Diagnostic Table

DIFFERENTIALS

8. General Diagnostic Table

A: INSPECTION

Symptom or trouble	Possible cause	Remedy
1. Oil leakage	(1) Worn, scratched, or incorrectly seated front or side oil seal. Scored, battered, or excessively worn sliding surface of companion flange.	Repair or replace.
	(2) Clogged or damaged air breather cap.	Clean, repair or replace.
	(3) Loose bolts on differential spindle or side bearing retainer, or incorrectly fitted O-ring.	Tighten the bolts to specified torque. Replace the O-ring.
	(4) Loose rear cover attaching bolts or damaged gasket.	Tighten the bolts to specified torque. Replace the gasket and apply liquid gasket.
	(5) Loose oil filler or drain plug.	Retighten and apply liquid gasket.
	(6) Wear, damage or incorrectly fitting for spindle, side bearing retainer and oil seal.	Repair or replace.
2. Seizure NOTE: Seized or damaged parts should be replaced, and also other parts should be thoroughly checked for any defect and should be repaired or replaced as required.	(1) Insufficient backlash for hypoid gear.	Readjust or replace.
	(2) Excessive preload for side, rear, or front bearing.	Readjust or replace.
	(3) Insufficient or improper oil used.	Replace the seized part and fill with specified oil to specified level.
3. Damage NOTE: Damaged parts should be replaced, and also other parts should be thoroughly checked for any defect and should be repaired or replaced as required.	(1) Improper backlash for hypoid gear.	Replace.
	(2) Insufficient or excessive preload for side, rear, or front bearing.	Readjust or replace.
	(3) Excessive backlash for differential gear.	Replace the gear or thrust washer.
	(4) Loose bolts and nuts such as hypoid driven gear bolt.	Retighten.
	(5) Damage due to overloading.	Replace.
4. Noises when starting or shifting gears NOTE: Noises may be caused by differential assembly, universal joint, wheel bearing, etc. Find out what is actually making noise before disassembly.	(1) Excessive backlash for hypoid gear.	Readjust.
	(2) Excessive backlash for differential gear.	Replace the gear or thrust washer.
	(3) Insufficient preload for front or rear bearing.	Readjust.
	(4) Loose drive pinion nut.	Tighten to specified torque.
	(5) Loose bolts and nuts such as side bearing retainer attaching bolt.	Tighten to specified torque.
5. Noises when cornering	(1) Damaged differential gear.	Replace.
	(2) Excessive wear or damage of thrust washer.	Replace.
	(3) Broken pinion mate shaft.	Replace.
	(4) Seized or damaged side bearing.	Replace.

General Diagnostic Table

DIFFERENTIALS

Symptom or trouble	Possible cause	Remedy
6. Gear noises NOTE: Since noises from engine, muffler, transmission, propeller shaft, wheel bearings, tires, and body are sometimes mistaken for noises from differential assembly, be careful in checking them. Inspection methods to locate noises include coasting, accelerating, cruising, and lifting-up all four wheels. Perform these inspections according to condition of trouble. When listening to noises, shift gears into four wheel drive and fourth speed position, trying to pick up only differential noise.	(1) Improper tooth contact of hypoid gear.	Readjust or replace the hypoid gear set.
	(2) Improper backlash for hypoid gear.	Readjust.
	(3) Scored or chipped teeth of hypoid gear.	Replace the hypoid gear set.
	(4) Seized hypoid gear.	Replace the hypoid gear set.
	(5) Improper preload for front or rear bearings.	Readjust.
	(6) Seized, scored, or chipped front or rear bearing.	Replace.
	(7) Seized, scored, or chipped side bearing.	Replace.
	(8) Vibrating differential carrier.	Replace.

General Diagnostic Table

DIFFERENTIALS
