

ABS

General Description

ABS

1. General Description

A: SPECIFICATION

Item			Standard value or identification	
ABS wheel speed sensor	ABS wheel speed sensor gap	Front	0.3 — 0.8 mm (0.012 — 0.031 in)	
		Rear	0.7 — 1.2 mm (0.028 — 0.047 in)	
	ABS wheel speed sensor resistance	Front	1.25±0.25 kΩ	
		Rear	1.15±0.115 kΩ	
	Marks of harness	Front	RH	White
			LH	Yellow
Rear		RH	Light blue	
		LH	Brown	
G sensor	G sensor voltage		2.3±0.2 V	
Lateral G sensor (STI model)	Lateral G sensor voltage		2.5±0.2 V	
ABSCM&H/U marks	AT model		PK	
	MT model (Except STI model)		PL	
	MT model (STI model)		MJ	

B: COMPONENT

1. SENSOR

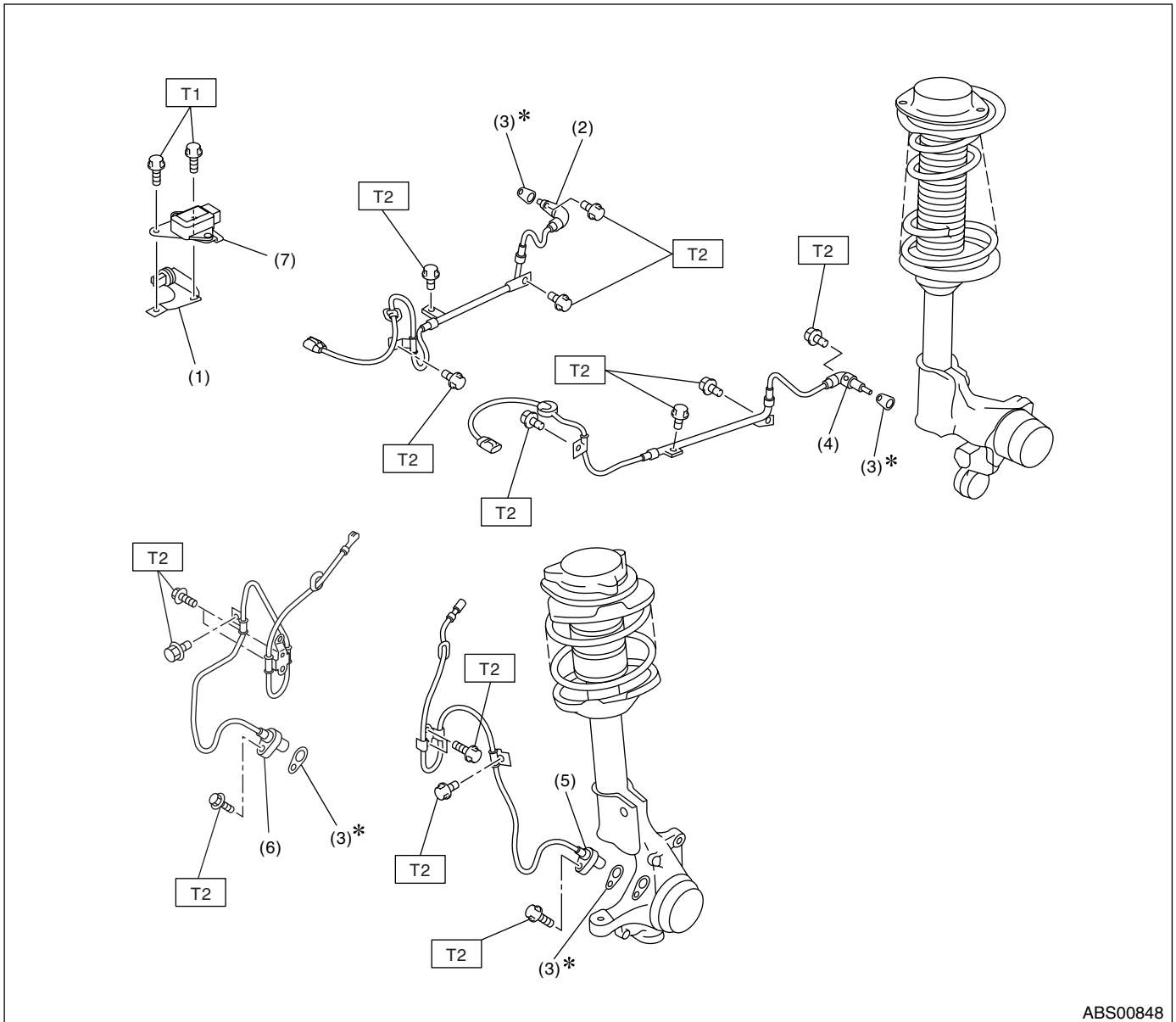

ABS00848

- | | |
|------------------------------------|---|
| (1) G sensor | (5) Front ABS wheel speed sensor LH |
| (2) Rear ABS wheel speed sensor RH | (6) Front ABS wheel speed sensor RH |
| (3) Adjusting spacer | (7) Yaw rate & lateral G sensor (STI model) |
| (4) Rear ABS wheel speed sensor LH | |

Tightening torque: N·m (kgf·m, ft·lb)

T1: 18 (1.8, 13.0)

T2: 33 (3.3, 24)

General Description

ABS

2. ABS CONTROL MODULE AND HYDRAULIC CONTROL UNIT (ABSCM&H/U)

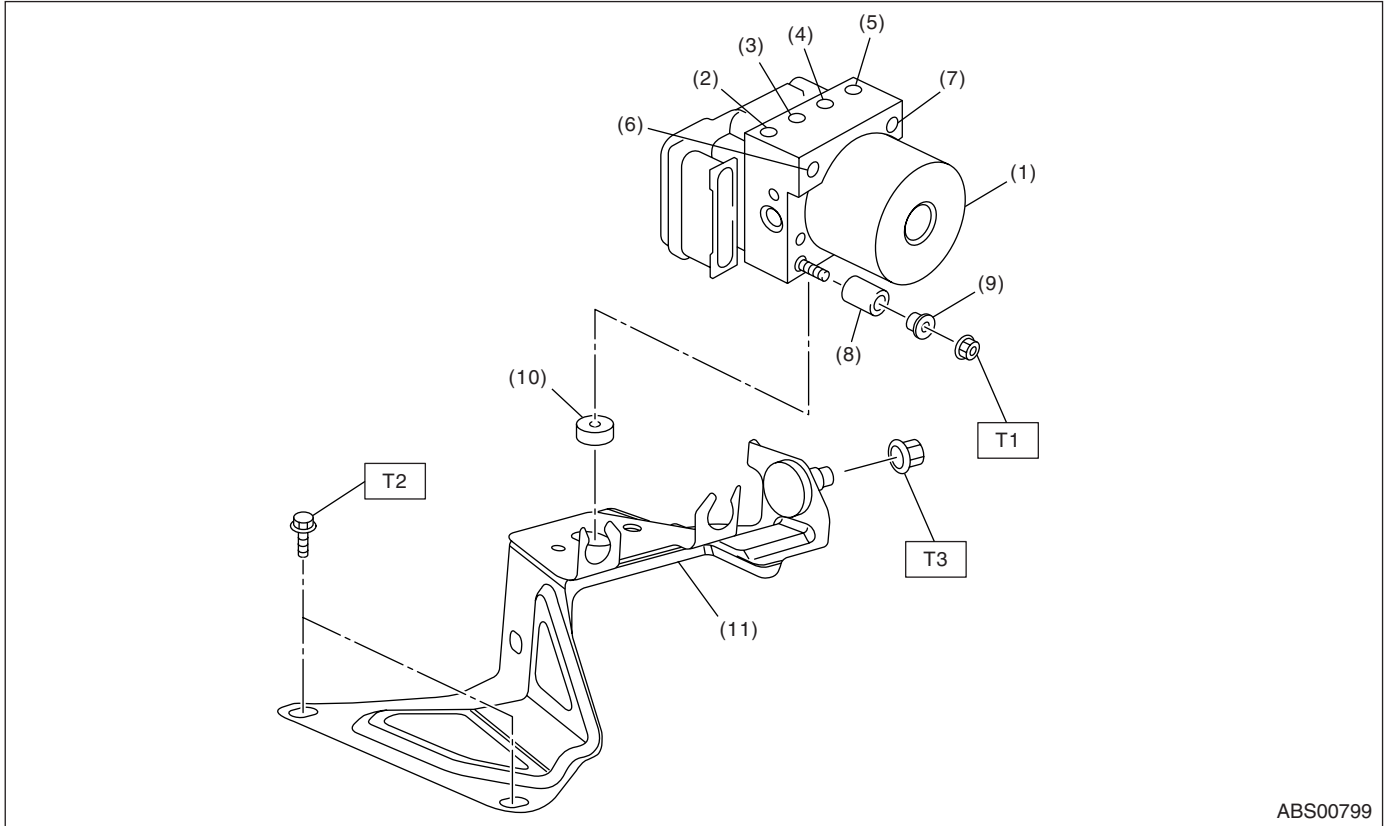

ABS00799

- | | |
|---|---------------------|
| (1) ABS control module and hydraulic control unit (ABSCM&H/U) | (6) Primary inlet |
| (2) Front outlet RH | (7) Secondary inlet |
| (3) Rear outlet LH | (8) Damper |
| (4) Rear outlet RH | (9) Spacer |
| (5) Front outlet LH | (10) Damper |
| | (11) Bracket |

Tightening torque: N·m (kgf·m, ft·lb)

T1: 7.5 (0.76, 5.5)

T2: 33 (3.3, 24)



T3: 38 (3.8, 27.5)

C: CAUTION

- Wear work clothing, including a cap, protective goggles and protective shoes during operation.
- Before disconnecting electrical connectors of sensors or units, be sure to disconnect the ground cable from battery.
- Before removal, installation or disassembly, be sure to clarify the failure. Avoid unnecessary removal, installation, disassembly, and replacement.
- Be careful not to burn yourself, because each part in the vehicle is hot after running.
- Be sure to tighten fasteners including bolts and nuts to the specified torque.
- Place shop jacks or rigid racks at the specified points.

D: PREPARATION TOOL

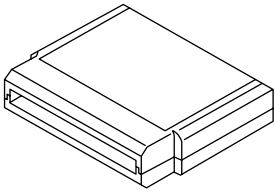
1. SPECIAL TOOL

ILLUSTRATION	TOOL NUMBER	DESCRIPTION	REMARKS
 ST18482AA010	18482AA010 (Newly adopted tool)	CARTRIDGE	Troubleshooting for electrical systems.
 ST22771AA030	22771AA030	SUBARU SELECT MONITOR KIT	Troubleshooting for electrical systems.

2. GENERAL TOOL

TOOL NAME	REMARKS
Circuit tester	Used for measuring resistance, voltage and ampere.
Pressure gauge	Used for measuring oil pressure.
Oscilloscope	Used for measuring sensor.
TORX® BIT E5	Used for removing ABSCM.

ABS Control Module and Hydraulic Control Unit (ABSCM&H/U)

ABS

2. ABS Control Module and Hydraulic Control Unit (ABSCM&H/U)

A: REMOVAL

- 1) Disconnect the ground cable from battery.
- 2) Remove the air intake duct and air cleaner case from the engine compartment to facilitate removal of ABSCM&H/U. <Ref. to IN(H4SO)-5, REMOVAL, Air Cleaner Case.> <Ref. to IN(H4SO)-7, REMOVAL, Air Intake Duct.> <Ref. to IN(H4DOTC)-8, REMOVAL, Air Cleaner Case.> <Ref. to IN(H4DOTC)-9, REMOVAL, Air Intake Duct.>
- 3) Use compressed air to get rid of water around the ABSCM&H/U.

NOTE:

Contact will be insufficient if the terminal gets wet.

- 4) Disconnect the ABSCM&H/U connector pulling up the lock lever.

CAUTION:

Do not pull the harness when disconnecting connector.

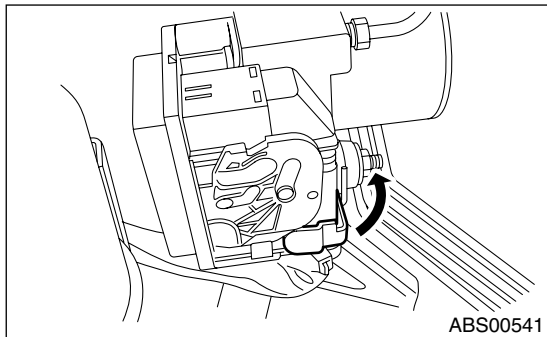

- 5) Remove the harness clip.
- 6) Disconnect the brake pipes from ABSCM&H/U.
- 7) Wrap the brake pipe using a vinyl bag not to spill the brake fluid on the vehicle body.

CAUTION:

When brake fluid is attached to the vehicle body, wash it off with water and wipe the water.

- 8) Remove the nuts and remove the ABSCM&H/U.

CAUTION:

- Do not drop or bump the ABSCM&H/U.
- Do not turn ABSCM&H/U upside down or place it sideways for storage.
- Be careful that no foreign objects are mixed in ABSCM&H/U.

- Be careful that no water enters inside the connectors.

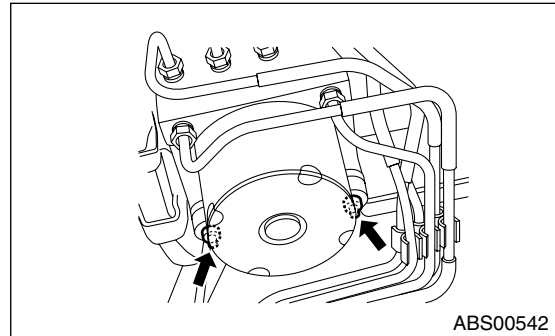

- 9) Remove the ABSCM&H/U bracket.

B: INSTALLATION

- 1) Install the ABSCM&H/U bracket.

Tightening torque:

33 N·m (3.3 kgf-m, 24 ft-lb)

- 2) Install the ABSCM&H/U aligning the groove of damper on ABSCM&H/U side with the pawl of bracket.

NOTE:

Check the identification mark of ABSCM&H/U.

Tightening torque:

7.5 N·m (0.76 kgf-m, 5.5 ft-lb)

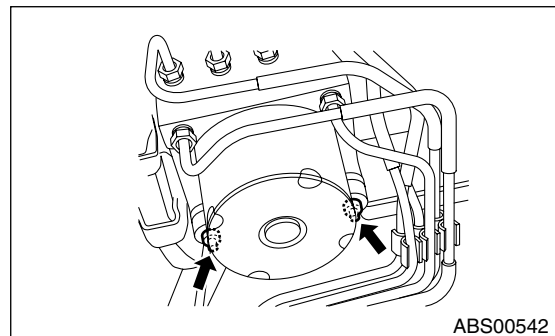

- 3) Connect the brake pipes to their correct ABSCM&H/U connections.

Tightening torque:

15 N·m (1.5 kgf-m, 10.8 ft-lb)

- 4) Using the cable clip, secure the ABSCM&H/U harness to bracket.
- 5) Connect the connector to ABSCM&H/U.

NOTE:

- Be sure to remove all foreign matter from inside of the connector before connecting.
- Ensure that the ABSCM&H/U connector is securely locked.

- 6) Connect the ground cable to ABSCM&H/U, and then apply anti-corrosive wax.

- 7) Install the air cleaner case and air intake duct.
 <Ref. to IN(H4SO)-5, INSTALLATION, Air Cleaner Case.> <Ref. to IN(H4SO)-7, INSTALLATION, Air Intake Duct.> <Ref. to IN(H4DOTC)-8, INSTALLATION, Air Cleaner Case.> <Ref. to IN(H4DOTC)-9, INSTALLATION, Air Intake Duct.>
- 8) Bleed air from the brake system.

C: REPLACEMENT

CAUTION:

- Because the seal of ABSCM cannot be replaced, do not pull or peel it with lifting up.
- Because the screw part of H/U deteriorates in every replacement procedure, do not perform the replacement more than five times on it. When the malfunction is found though the replacement that performed is less than five times, replace the H/U body.
- Use new screws for installation of ABSCM.
- When the sealing surface of ABSCM or H/U is dirty or damaged and it cannot be removed or repaired, replace it with new one.

- 1) Remove the ABSCM&H/U. <Ref. to ABS-6, REMOVAL, ABS Control Module and Hydraulic Control Unit (ABSCM&H/U).>
- 2) To prevent entering foreign matter and brake fluid leakage, plug the oil pressure port of ABSCM&H/U using screw plug and etc.
- 3) Set the pump motor part of removed ABSCM&H/U faces down in the vise.

NOTE:

Before securing a part on a vice, place cushioning material such as wood blocks, aluminum plate or cloth between the part and vice.

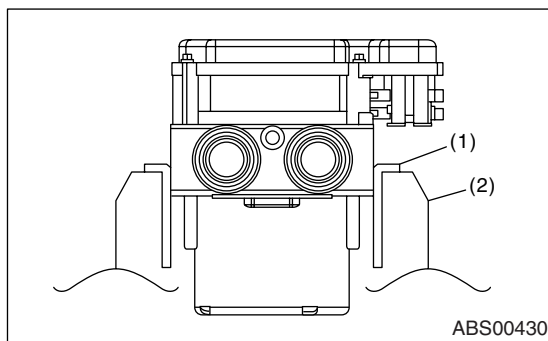

- (1) Aluminum plate or etc.
 (2) Vise

- 4) Using TORX® BIT E5, remove the four screws of ABSCM.

NOTE:

Always use new screws.

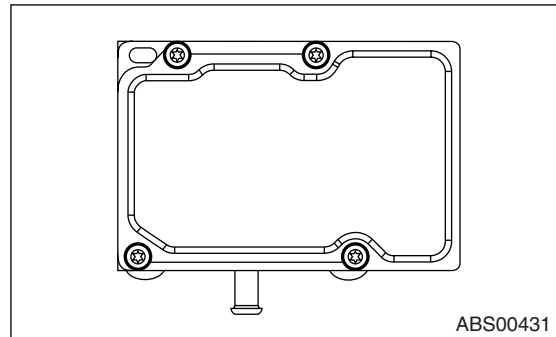

- 5) Slowly remove the ABSCM upward from H/U.

NOTE:

To prevent damaging of coil part, remove the ABSCM straightly from H/U.

- 6) Ensure there are no dirt or damage on sealing surface of H/U.

CAUTION:

- Do not clean the ABSCM & H/U with applying compressed air.
- Do not repair the damages of H/U sealing surface using file or metal scraper. To remove the sealing, use resin scraper. Do not use the chemical materials (thinner and etc.).

- 7) Position the coil of new ABSCM to align H/U valve.

- 8) To prevent deforming of ABSCM housing cover, hold the corner of ABSCM and install it to the H/U without tilting.

- 9) Using TORX® BIT E5, tighten the screws stepwise in the order of (1) through (4).

CAUTION:

Always use new screws.

Tightening torque:

1.5 N·m (0.15 kgf·m, 1.1 ft·lb)

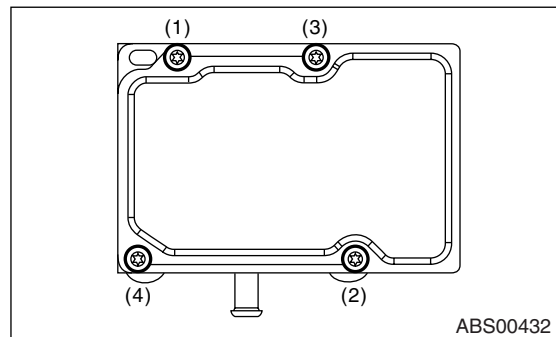

- 10) Check that there is no foreign matter in aligning part between ABSCM and H/U.

ABS Control Module and Hydraulic Control Unit (ABSCM&H/U)

ABS

11) Using TORX® BIT E5, tighten the screws stepwise in the order of (1) through (4) again.

Tightening torque:

3 N·m (0.3 kgf·m, 2.2 ft·lb)

12) Check that there is no clearance in aligning part between ABSCM and H/U.

13) Install the ABSCM&H/U to vehicle. <Ref. to ABS-6, INSTALLATION, ABS Control Module and Hydraulic Control Unit (ABSCM&H/U).>

D: INSPECTION

1) Check the connected and fixed condition of connector.

2) Check specifications of the mark with ABSCM&H/U.

Mark	Model
PK	AT
PL	MT (Except for STI)
MJ	STI

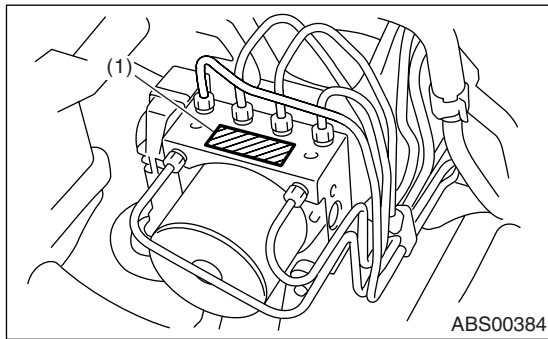

(1) Mark

1. CHECKING THE HYDRAULIC UNIT ABS OPERATION BY PRESSURE GAUGE

1) Lift-up the vehicle and remove the wheels.

2) Disconnect the air bleeder screws from the FL and FR caliper bodies.

3) Connect two pressure gauges to the FL and FR caliper bodies.

CAUTION:

- Pressure gauges used exclusively for brake fluid must be used.
- Do not employ pressure gauge previously used for transmission oil pressure since the piston seal is expanded which may lead to malfunction of the brake.

NOTE:

Wrap sealing tape around the pressure gauge.

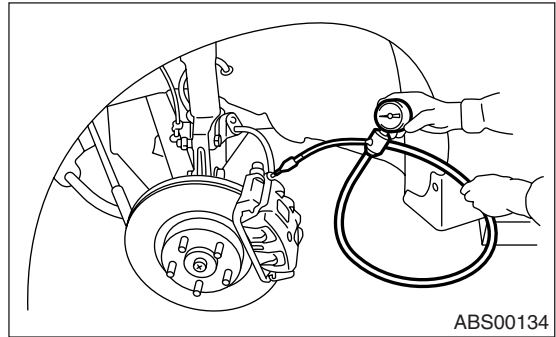

ABS00134

4) Bleed air from the pressure gauges.

5) Perform the ABS sequence control.

<Ref. to ABS-10, ABS Sequence Control.>

6) When the hydraulic unit begins to work and first the FL side performs decompression, holding and compression, and then the FR side performs decompression, holding and compression.

7) Read values indicated on the pressure gauge and check if the fluctuation of the values between decompression and compression meets the standard values. Also check if any irregular brake pedal tightness is felt.

	Front wheel	Rear wheel
Initial value	3,500 kPa (35 kgf/cm ² , 498 psi)	3,500 kPa (35 kgf/cm ² , 498 psi)
Decompressed	500 kPa (5 kgf/cm ² , 71 psi) or less	500 kPa (5 kgf/cm ² , 71 psi) or less
Compressed	3,500 kPa (35 kgf/cm ² , 498 psi) or more	3,500 kPa (35 kgf/cm ² , 498 psi) or more

8) Remove the pressure gauges from FL and FR caliper bodies.

9) Remove the air bleeder screws from the RL and RR caliper bodies.

10) Connect the air bleeder screws to the FL and FR caliper bodies.

11) Connect two pressure gauges to the RL and RR caliper bodies.

12) Bleed air from the FL and FR caliper bodies.

13) Perform the ABS sequence control.

<Ref. to ABS-10, ABS Sequence Control.>

14) When the hydraulic unit begins to work, at first the RR side performs decompression, holding and compression, and then the RL side performs decompression, holding and compression.

15) Read values indicated on the pressure gauges and check if they meet the standard value.

- 16) After checking, remove the pressure gauges from caliper bodies.
- 17) Connect the air bleeder screws to RL and RR caliper bodies.
- 18) Bleed air from the brake system.

2. CHECKING THE HYDRAULIC UNIT ABS OPERATION WITH BRAKE TESTER

1) In the case of non-turbo AT model, install a spare fuse with the FWD connector in the main fuse box to simulate FWD model.

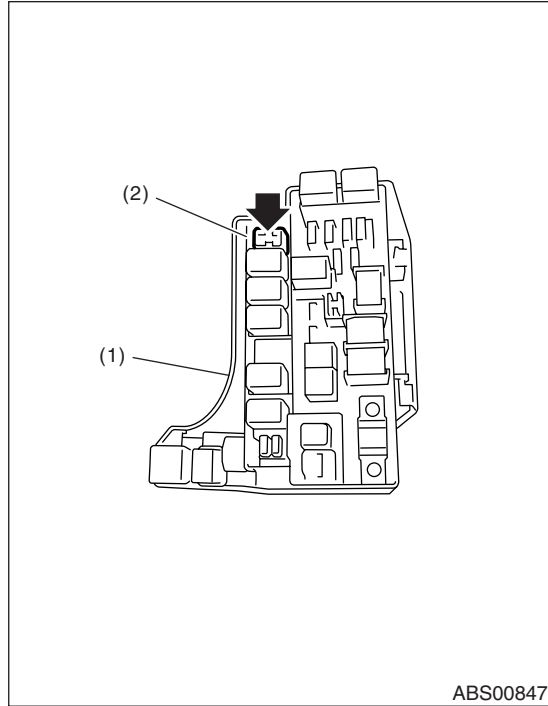

- (1) Main fuse box
- (2) FWD connector

NOTE:

The AWD circuit of MT and turbo AT model can not be disabled.

2) Prepare for operating the ABS sequence control.
<Ref. to ABS-10, ABS Sequence Control.>

3) Set the front wheels or rear wheels on the brake tester and set the select lever's position at "N" range.

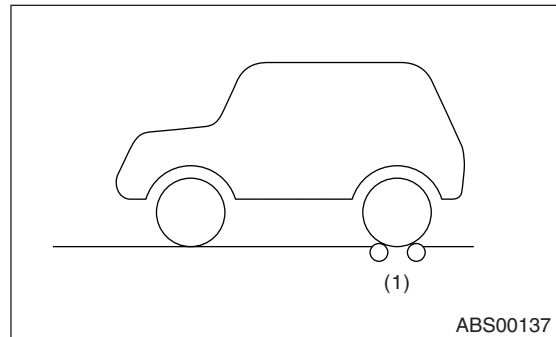
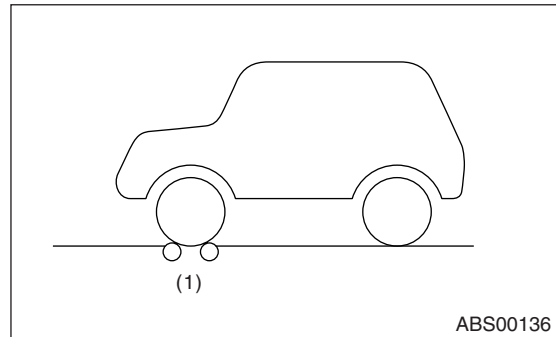

(1) Brake tester

- 4) Operate the brake tester.
- 5) Perform the ABS sequence control.
<Ref. to ABS-10, ABS Sequence Control.>
- 6) Hydraulic unit begins to work; and check the following working sequence.

(1) The FL side performs decompression, holding and compression in sequence, and subsequently the FR side repeats the cycle.

(2) The RR side performs decompression, holding and compression in sequence, and subsequently the RL side repeats the cycle.

7) Read values indicated on the brake tester and check if the fluctuation of values, while decompressed and compressed, meet the standard values.

	Front wheel	Rear wheel
Initial value	1,000 N (100 kgf, 221 lbf)	1,000 N (100 kgf, 221 lbf)
Decompressed	500 N (50 kgf, 110 lbf) or less	500 N (50 kgf, 110 lbf) or less
Compressed	1,000 N (100 kgf, 221 lbf) or more	1,000 N (100 kgf, 221 lbf) or more

8) After checking, also check if any irregular brake pedal tightness is felt.

3. ABS Sequence Control

A: OPERATION

- 1) Under the ABS sequence control, after the hydraulic unit solenoid valve is driven, the operation of the hydraulic unit can be checked by means of the brake tester or pressure gauge.
- 2) ABS sequence control can be started by Subaru Select Monitor.

1. ABS SEQUENCE CONTROL WITH SUBARU SELECT MONITOR

NOTE:

In the event of any trouble, the sequence control may not be operative. In such a case, perform the diagnosis. <Ref. to ABS(diag)-2, PROCEDURE, Basic Diagnostic Procedure.>

- 1) Connect the Subaru Select Monitor to data link connector under driver's seat instrument panel lower cover.
- 2) Turn the ignition switch to ON.
- 3) Turn the Subaru Select Monitor switch to ON.
- 4) Put the Subaru Select Monitor to {BRAKE CONTROL} mode.
- 5) When {Function check sequence} is selected, ABS sequence control will start.
- 6) When the message {Press Brake Pedal with braking force of 100 to 150 kgf} is displayed, perform the followings.
 - (1) When using the brake tester, depress the brake pedal with braking force of 981 N (100 kgf, 221 lbf).
 - (2) When using the pressure gauge, depress the brake pedal so as to make the pressure gauge indicate 3,432 kPa (35 kgf/cm², 498 psi).
- 7) When the message {Press YES} is displayed, press the [YES] key.
- 8) The braking system in operation is displayed on Subaru Select Monitor.

2. CONDITIONS FOR ABS SEQUENCE CONTROL

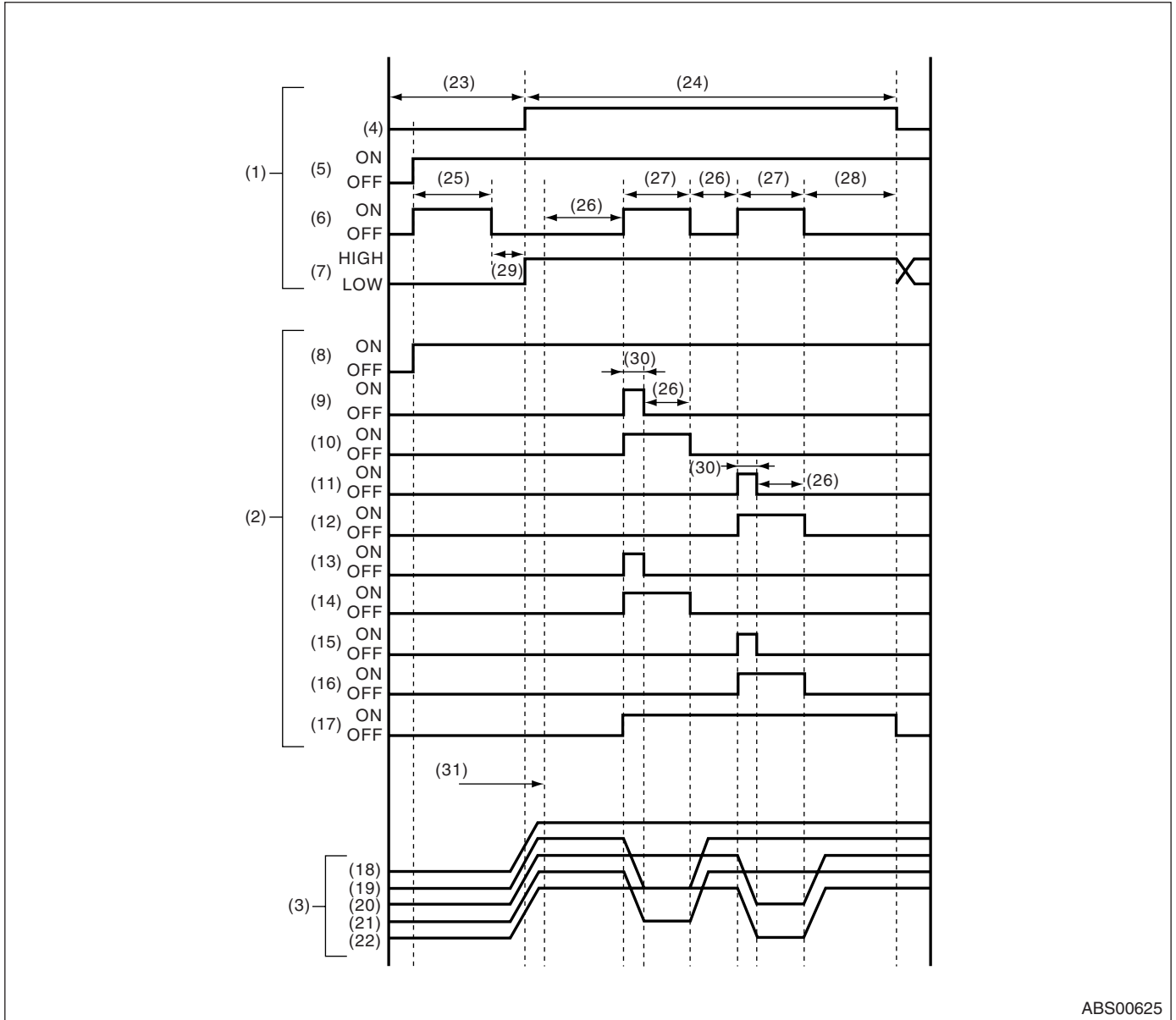

- | | | |
|--|------------------------------------|------------------------------------|
| (1) Operational guide line of sequence control | (10) FL inlet valve | (22) Pressure of RL wheel cylinder |
| (2) Operational pattern of sequence control | (11) FR outlet valve | (23) 4 km/h (2 MPH) or less |
| (3) Operational pressure of sequence control | (12) FR inlet valve | (24) 10 km/h (6 MPH) or less |
| (4) Speed of all wheels | (13) RR outlet valve | (25) Approx. 2.0 seconds |
| (5) Ignition key switch | (14) RR inlet valve | (26) 1.0 second |
| (6) ABS warning light | (15) RL outlet valve | (27) 1.4 seconds |
| (7) Stop light switch | (16) RL inlet valve | (28) 0.6 seconds |
| (8) Valve relay | (17) Pump motor | (29) Within 0.5 seconds |
| (9) FL outlet valve | (18) Pressure of master cylinder | (30) 0.4 seconds |
| | (19) Pressure of FL wheel cylinder | (31) Point A |
| | (20) Pressure of FR wheel cylinder | |
| | (21) Pressure of RR wheel cylinder | |

NOTE:

- When the Subaru Select Monitor is used, control operation starts at point A. (However, the stop light switch must be ON before point A.)
- HIGH means high voltage.
- LOW means low voltage.

B: SPECIFICATION

1. CONDITIONS FOR COMPLETION OF ABS SEQUENCE CONTROL

When the following conditions develop, the ABS sequence control stops and ABS operation is returned to the normal control mode.

- 1) When the speed of at least one wheel reaches 10 km/h (6 MPH).
- 2) When the brake pedal is released during sequence control and the stop light switch is set to off.
- 3) After completion of the sequence control.
- 4) When malfunction is detected.

4. Front ABS Wheel Speed Sensor

A: REMOVAL

- 1) Disconnect the ground cable from battery.
- 2) Disconnect the front ABS wheel speed sensor connector located next to the front strut mounting house in engine compartment. Pull the connector out from grommet hole to tire side.
- 3) Remove the bolts which secure the sensor harness to strut.

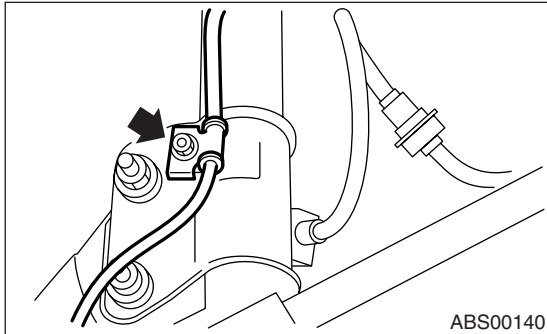

- 4) Remove the bolts which secure the sensor harness to body.

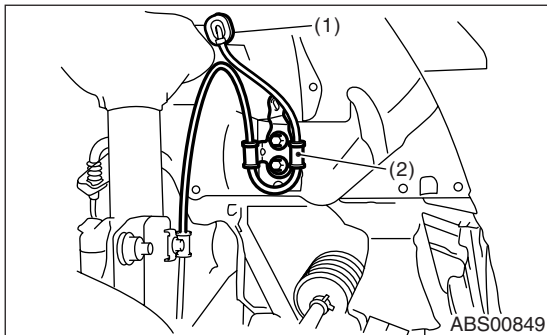

- (1) To front ABS wheel speed sensor connector
- (2) Bracket

- 5) Remove the bolts which secure the front ABS wheel speed sensor to housing, and remove the front ABS wheel speed sensor.

CAUTION:

- Be careful not to damage the pole piece located at tip of the sensor and teeth faces during removal.

- Do not pull the sensor harness during removal.

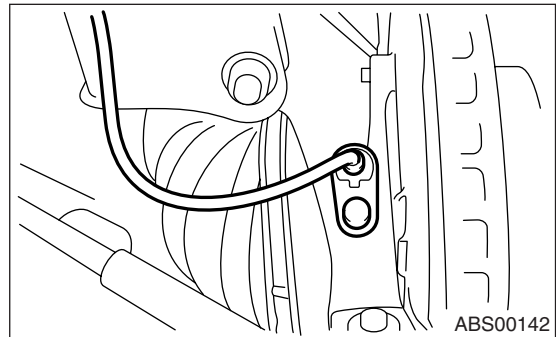

B: INSTALLATION

- 1) Temporarily install the front ABS wheel speed sensor on housing.

CAUTION:

- Be careful not to strike the ABS wheel speed sensor's pole piece against tone wheel and adjacent metal parts during installation.

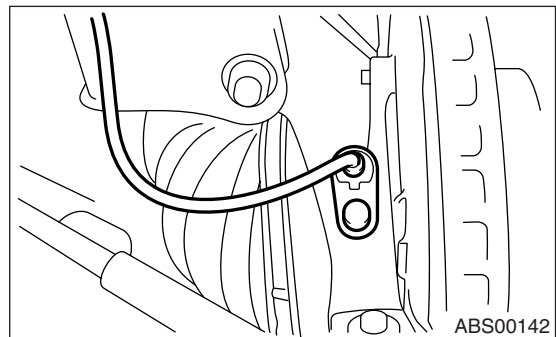

- 2) Install the front ABS wheel speed sensor on strut and wheel apron.

Tightening torque:

33 N·m (3.3 kgf-m, 24 ft-lb)

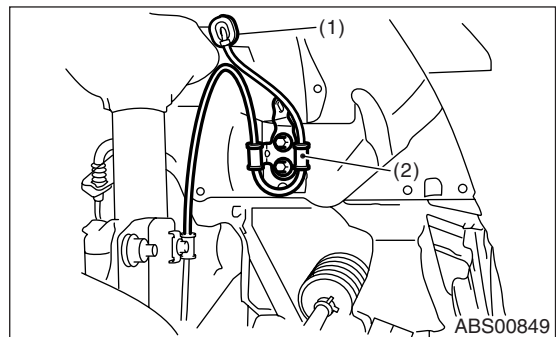

- (1) To front ABS wheel speed sensor connector
- (2) Bracket

- 3) Check the ABS wheel speed sensor gap. <Ref. to ABS-14, SENSOR GAP, INSPECTION, Front ABS Wheel Speed Sensor.> After standard clearance is obtained, tighten the ABS wheel speed sensor on housing to specified torque.

Front ABS Wheel Speed Sensor

ABS

If the clearance is outside specification, readjust using spacer (Part No. 26755AA000).

ABS wheel speed sensor standard clearance:
0.3 — 0.8 mm (0.012 — 0.031 in)

Tightening torque:
33 N·m (3.3 kgf·m, 24 ft·lb)

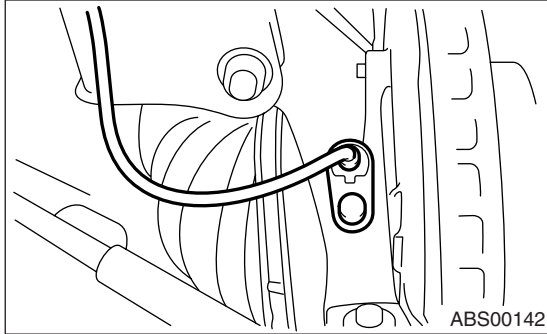

NOTE:

- Check the marks on the harness and make sure that no kink exists. (RH: White, LH: Yellow)
- Make sure the harness is not pulled and does not contact to suspension or body when steering wheel is turned.

4) After confirmation of the ABS wheel speed sensor clearance, connect the connector to ABS wheel speed sensor.

5) Connect the battery ground cable to battery.

C: INSPECTION

1. ABS WHEEL SPEED SENSOR

1) Check the pole piece of ABS wheel speed sensor for foreign particles or damage. If necessary, clean the pole piece or replace ABS wheel speed sensor.

2) Measure the ABS wheel speed sensor resistance.

If the resistance is outside standard value, replace the ABS wheel speed sensor with a new one.

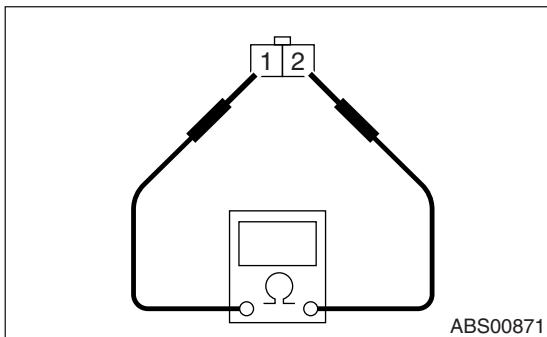

Terminal No.	Standard
1 and 2	1.25±0.25 kΩ

NOTE:

Check the ABS wheel speed sensor cable for discontinuity. If necessary, replace with a new one.

2. SENSOR GAP

1) Measure the distance “A” between ABS wheel speed sensor surface and sensor pole face.

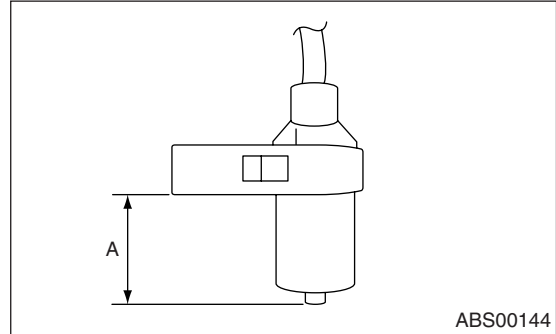

2) Measure the distance “B” between surface where the front axle housing meets the ABS wheel speed sensor, and the tone wheel.

NOTE:

Measure so that the gauge touches the tone wheel teeth top.

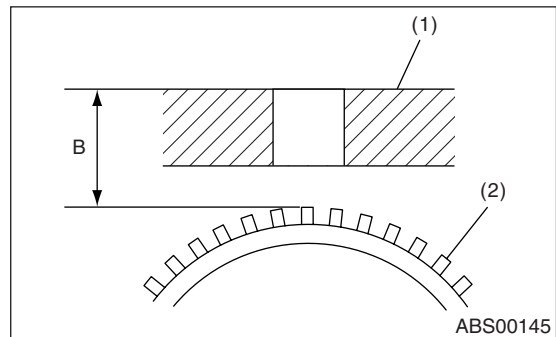

- (1) Axle housing
 (2) Tone wheel

3) Find the gap between the ABS wheel speed sensor pole face and the surface of the tone wheel teeth by putting the measured values in the formula below and calculating.

$$\text{ABS wheel speed sensor clearance} = B - A$$

ABS wheel speed sensor standard clearance:
0.3 — 0.8 mm (0.012 — 0.031 in)

NOTE:

If the clearance is out of specification, readjust using spacer (Part No. 26755AA000).

3. OUTPUT VOLTAGE

Output voltage can be checked by the following method. Install the resistor and condenser, then rotate the wheel about 2.75 km/h (2 MPH) or equivalent.

Output voltage specification:
0.12 to 1 V (at 20 Hz)

NOTE:

Regarding terminal No., please refer to item 1. ABS WHEEL SPEED SENSOR. <Ref. to ABS-14, ABS WHEEL SPEED SENSOR, INSPECTION, Front ABS Wheel Speed Sensor.>

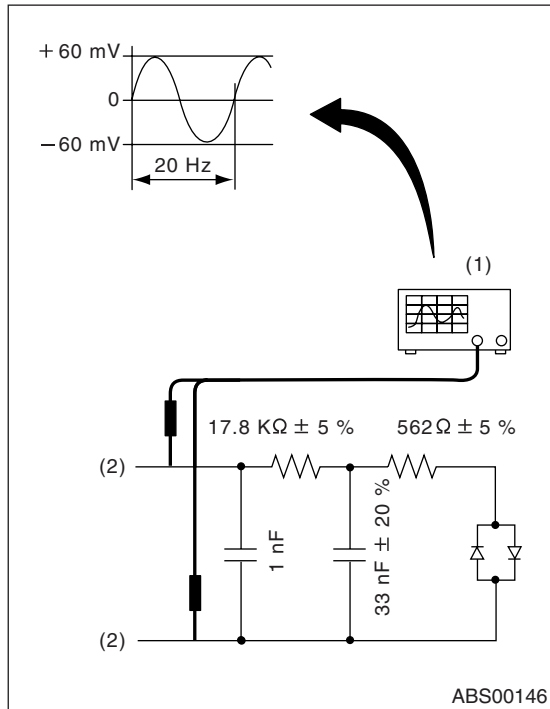

- (1) Oscilloscope
- (2) Terminal

D: ADJUSTMENT

Adjust the gap using spacer (Part No. 26755A000).

5. Rear ABS Wheel Speed Sensor

A: REMOVAL

- 1) Disconnect the ground cable from battery.
- 2) Lift-up the vehicle.
- 3) Remove the rear seat and disconnect the rear ABS wheel speed sensor connector. Pull the connector out from grommet hole to under floor.
- 4) Remove the rear sensor harness bracket from the rear trailing link and bracket.
- 5) Remove the rear ABS wheel speed sensor from back plate.

CAUTION:

- Be careful not to damage the pole piece located at tip of the sensor and teeth faces during removal.
- Do not pull the sensor harness during removal.

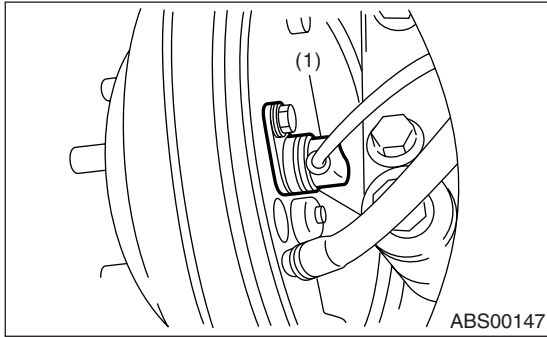

(1) Rear ABS wheel speed sensor

- 6) Remove the rear tone wheel while removing the hub from housing and hub assembly. <Ref. to DS-27, REMOVAL, Rear Axle.>

B: INSTALLATION

- 1) Install the rear tone wheel on hub, then rear housing on hub. <Ref. to DS-30, ASSEMBLY, Rear Axle.>
- 2) Temporarily install the rear ABS wheel speed sensor on back plate.

CAUTION:

Be careful not to strike the ABS wheel speed sensor's pole piece against tone wheel and adjacent metal parts during installation.

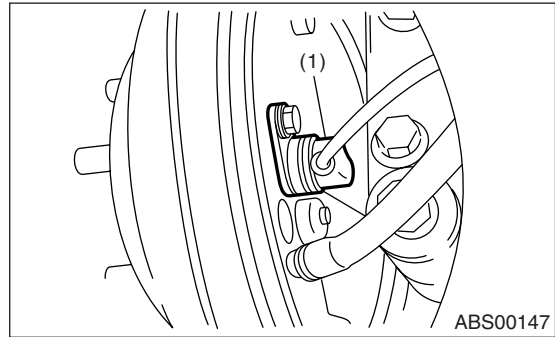

(1) Rear ABS wheel speed sensor

- 3) Install the rear drive shaft to rear housing and rear differential spindle. <Ref. to DS-28, INSTALLATION, Rear Axle.>
- 4) Install the rear sensor harness on rear trailing link.

Tightening torque:

33 N·m (3.3 kgf-m, 24 ft-lb)

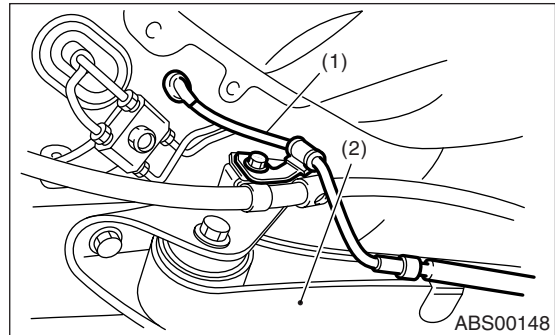

(1) Rear sensor harness

(2) Trailing link

- 5) Check the ABS wheel speed sensor gap. <Ref. to ABS-17, SENSOR GAP, INSPECTION, Rear ABS Wheel Speed Sensor.> After standard clearance is obtained, tighten the ABS wheel speed sensor on back plate to specified torque.

If the clearance is outside specification, readjust using spacer (Part No. 26755AA000).

ABS wheel speed sensor standard clearance:

0.7 — 1.2 mm (0.028 — 0.047 in)

Tightening torque:

33 N·m (3.3 kgf-m, 24 ft-lb)

NOTE:

Check the marks on the harness and make sure no kink exists. (RH: Light blue, LH: Brown)

- 6) After confirmation of the ABS wheel speed sensor clearance, connect the connector to ABS wheel speed sensor.
- 7) Connect the battery ground cable to battery.

C: INSPECTION

1. ABS WHEEL SPEED SENSOR

- 1) Check the pole piece of ABS wheel speed sensor for foreign particles or damage. If necessary, clean the pole piece or replace ABS wheel speed sensor.
 - 2) Measure the ABS wheel speed sensor resistance.
- If resistance is out of standard value, replace the ABS wheel speed sensor with a new one.

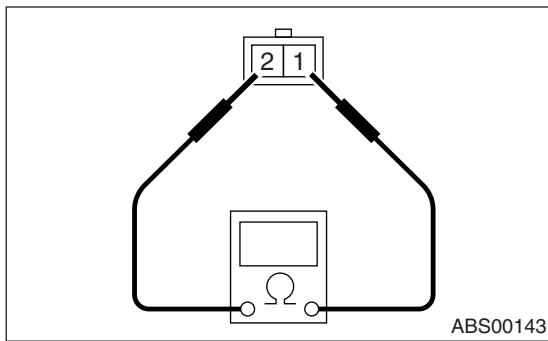

Terminal No.	Standard
1 and 2	1.15±0.115 kΩ

NOTE:
Check the ABS wheel speed sensor cable for discontinuity. If necessary, replace with a new one.

2. SENSOR GAP

- 1) Measure the clearance between tone wheel and ABS wheel speed sensor at whole periphery.

NOTE:
If clearance is narrow, adjust by using spacer (Part No. 26755AA000).
If clearance is wide, check the outputted voltage then replace the ABS wheel speed sensor or tone wheel if the outputted voltage is outside specification.

ABS wheel speed sensor clearance:
0.7 — 1.2 mm (0.028 — 0.047 in)

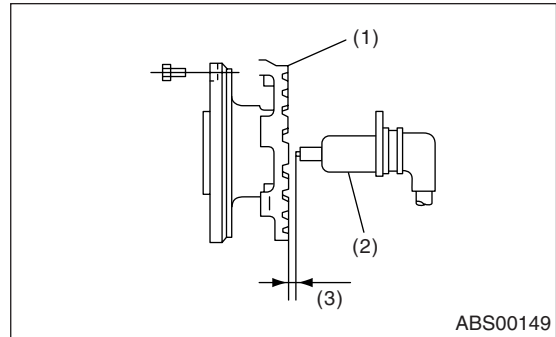

- (1) Tone wheel
- (2) ABS wheel speed sensor
- (3) Sensor gap

3. OUTPUT VOLTAGE

Output voltage can be checked by the following method. Install the resistor and condenser, then rotate the wheel about 2.75 km/h (2 MPH) or equivalent.

Output voltage specification:
0.12 — 1 V (at 20 Hz)

NOTE:
Regarding terminal No., please refer to item 1. ABS WHEEL SPEED SENSOR. <Ref. to ABS-17, ABS WHEEL SPEED SENSOR, INSPECTION, Rear ABS Wheel Speed Sensor.>

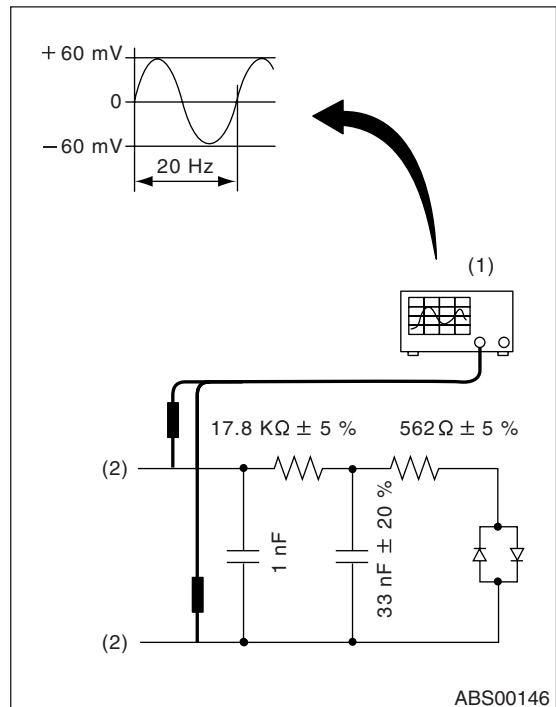

- (1) Oscilloscope
- (2) Terminal

D: ADJUSTMENT

Adjust the gap using spacer (Part No. 26755AA000).

6. Front Tone Wheel

A: REMOVAL

Refer to Front Drive Shaft, because front tone wheel is integrated with front drive shaft.

<Ref. to DS-33, REMOVAL, Front Drive Shaft.>

B: INSTALLATION

Refer to Front Drive Shaft, because front tone wheel is integrated with front drive shaft.

<Ref. to DS-33, INSTALLATION, Front Drive Shaft.>

C: INSPECTION

Visually check the tone wheel's teeth (44 pieces) for cracks or dents. If necessary, replace the tone wheel with a new one.

NOTE:

Tone wheel forms a unit with BJ assembly of drive shaft. Replace the BJ assembly when the tone wheel is damaged.

7. Rear Tone Wheel

A: REMOVAL

Refer to Rear Axle, because the rear tone wheel is installed to rear hub.

<Ref. to DS-27, REMOVAL, Rear Axle.>

B: INSTALLATION

Refer to Rear Axle, because the rear tone wheel is installed to rear hub.

<Ref. to DS-28, INSTALLATION, Rear Axle.>

C: INSPECTION

Visually check the tone wheel's teeth (44 pieces) for cracks or dents. If necessary, replace the tone wheel with a new one.

8. G Sensor

A: REMOVAL

- 1) Disconnect the ground cable from battery.
- 2) Remove the console cover. <Ref. to EI-46, REMOVAL, Console Box.>
- 3) Disconnect the connector from G sensor.
- 4) Remove the G sensor from body.

CAUTION:

- Do not drop or bump the G sensor.
- G sensor and the bracket are integrated into one unit. Therefore, do not disassemble it.
 - Except for STI model

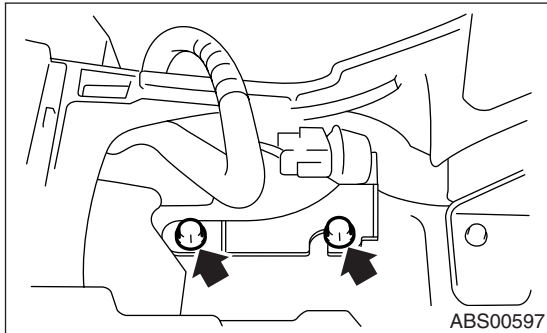

- STI model

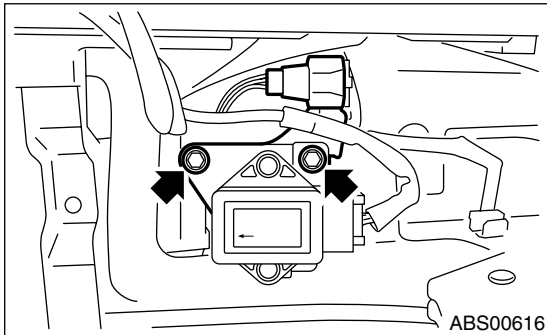

B: INSTALLATION

Install in the reverse order of removal.

CAUTION:

Do not drop or bump the G sensor.

Tightening torque:

18 N·m (1.8 kgf-m, 13.0 ft-lb)

G Sensor

ABS

C: INSPECTION

Step	Check	Yes	No
1	CHECK SUBARU SELECT MONITOR.	Go to step 5.	Go to step 2.
2	CHECK G SENSOR. 1) Turn the ignition switch to OFF. 2) Remove the G sensor from vehicle. 3) Connect the connector to G sensor. 4) Turn the ignition switch to ON. 5) Measure the voltage between G sensor connector terminals. <i>Connector & terminal</i> <i>(B292) No. 2 (+) — No. 3 (-):</i>	Go to step 3.	Replace the G sensor.
3	CHECK G SENSOR. Measure the voltage between G sensor connector terminals. <i>Connector & terminal</i> <i>(B292) No. 2 (+) — No. 3 (-):</i>	Go to step 4.	Replace the G sensor.
4	CHECK G SENSOR. Measure the voltage between G sensor connector terminals. <i>Connector & terminal</i> <i>(B292) No. 2 (+) — No. 3 (-):</i>	G sensor is normal.	Replace the G sensor.
5	CHECK G SENSOR. 1) Turn the ignition switch to OFF. 2) Connect the Subaru Select Monitor to data link connector. 3) Turn the Subaru Select Monitor into {BRAKE CONTROL} mode. 4) Set the display in the {Current Data Display & Save} mode. 5) Read the G sensor output value.	Go to step 6.	Replace the G sensor.
6	CHECK G SENSOR. 1) Remove the console box. 2) Remove the G sensor from vehicle. (Do not disconnect the connector.) 3) Read the Subaru Select Monitor display.	Go to step 7.	Replace the G sensor.
7	CHECK G SENSOR. Read the Subaru Select Monitor display.	G sensor is normal.	Replace the G sensor.

9. Yaw Rate and Lateral G Sensor

A: REMOVAL

For removal procedure of the yaw rate & lateral G sensor, refer to "6MT" section. <Ref. to 6MT-125, REMOVAL, Yaw Rate and Lateral G Sensor.>

B: INSTALLATION

For installation procedure of the yaw rate & lateral G sensor, refer to "6MT" section. <Ref. to 6MT-125, INSTALLATION, Yaw Rate and Lateral G Sensor.>

