

SECURITY AND LOCKS

General Description

SECURITY AND LOCKS

1. General Description

A: COMPONENT

1. DOOR LOCK ASSEMBLY

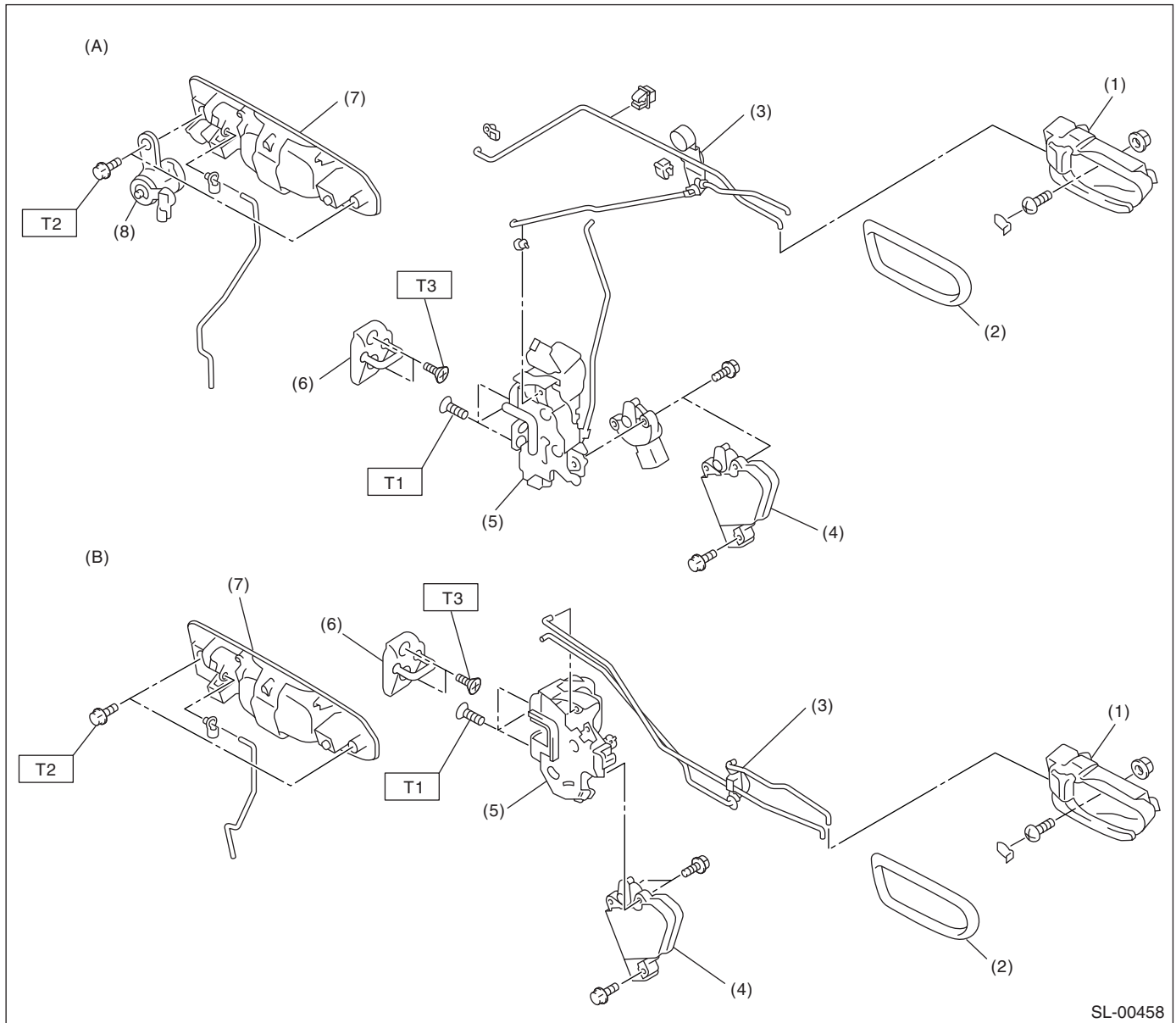

SL-00458

(A) Front

(B) Rear

- (1) Inner remote ASSY
- (2) Inner remote cover
- (3) Bell crank
- (4) Door lock actuator

- (5) Door latch
- (6) Striker
- (7) Outer handle
- (8) Key cylinder

Tightening torque: N-m (kgf-m, ft-lb)

T1: 6.4 (0.65, 4.7)

T2: 7.4 (0.75, 5.5)

T3: 17.6 (1.8, 13.0)

2. TRUNK LID AND REAR GATE LOCK

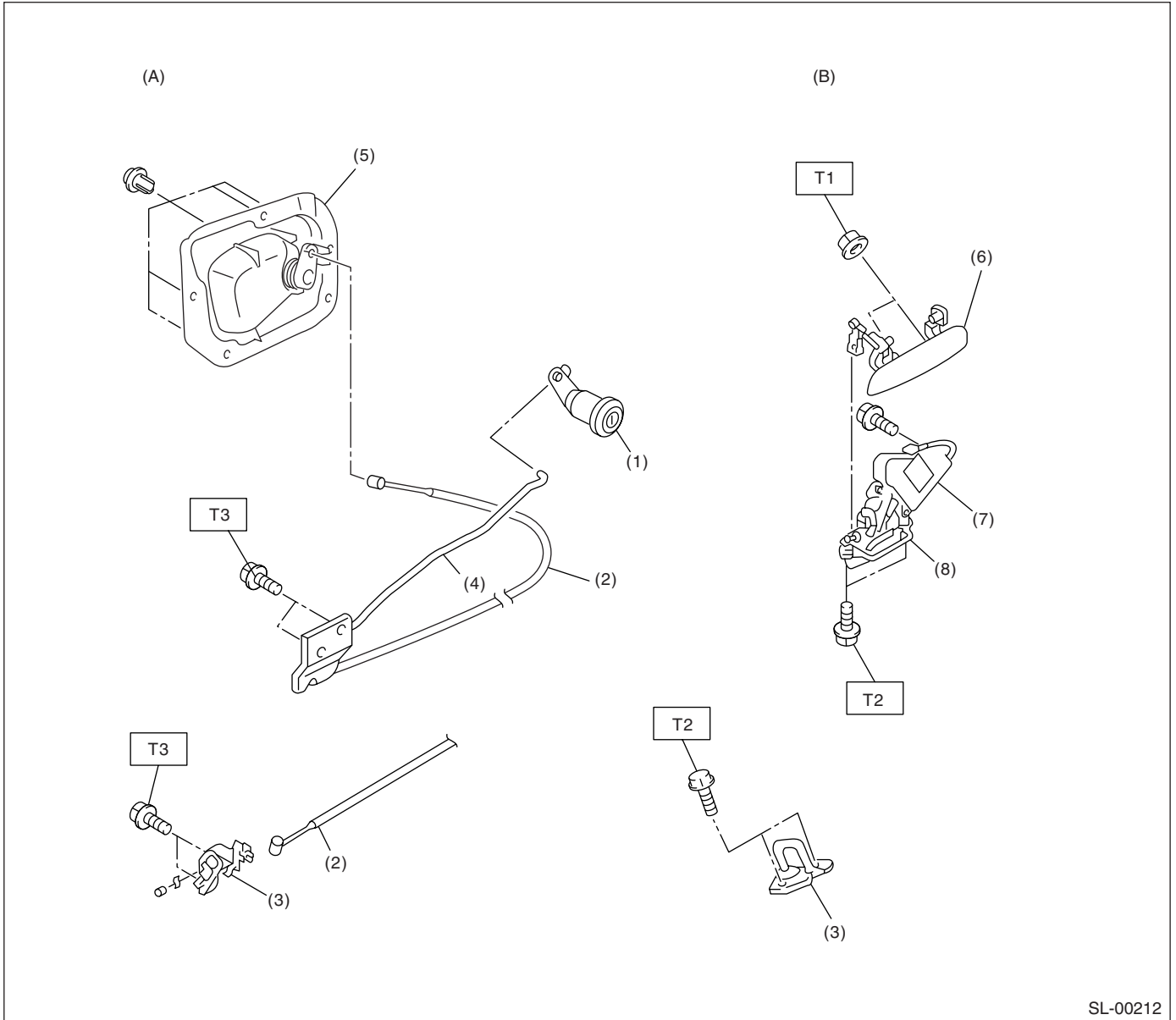

(A) Trunk

(B) Rear gate

- (1) Key cylinder
- (2) Cable
- (3) Striker
- (4) Trunk lid lock ASSY

- (5) Trunk lid release handle
- (6) Rear gate outer handle
- (7) Rear gate actuator
- (8) Rear gate latch

Tightening torque: N-m (kgf-m, ft-lb)

T1: 4.5 (0.45, 3.3)

T2: 25 (2.5, 18.4)

T3: 18 (1.84, 13.3)

General Description

SECURITY AND LOCKS

3. HOOD LOCK AND REMOTE OPENERS

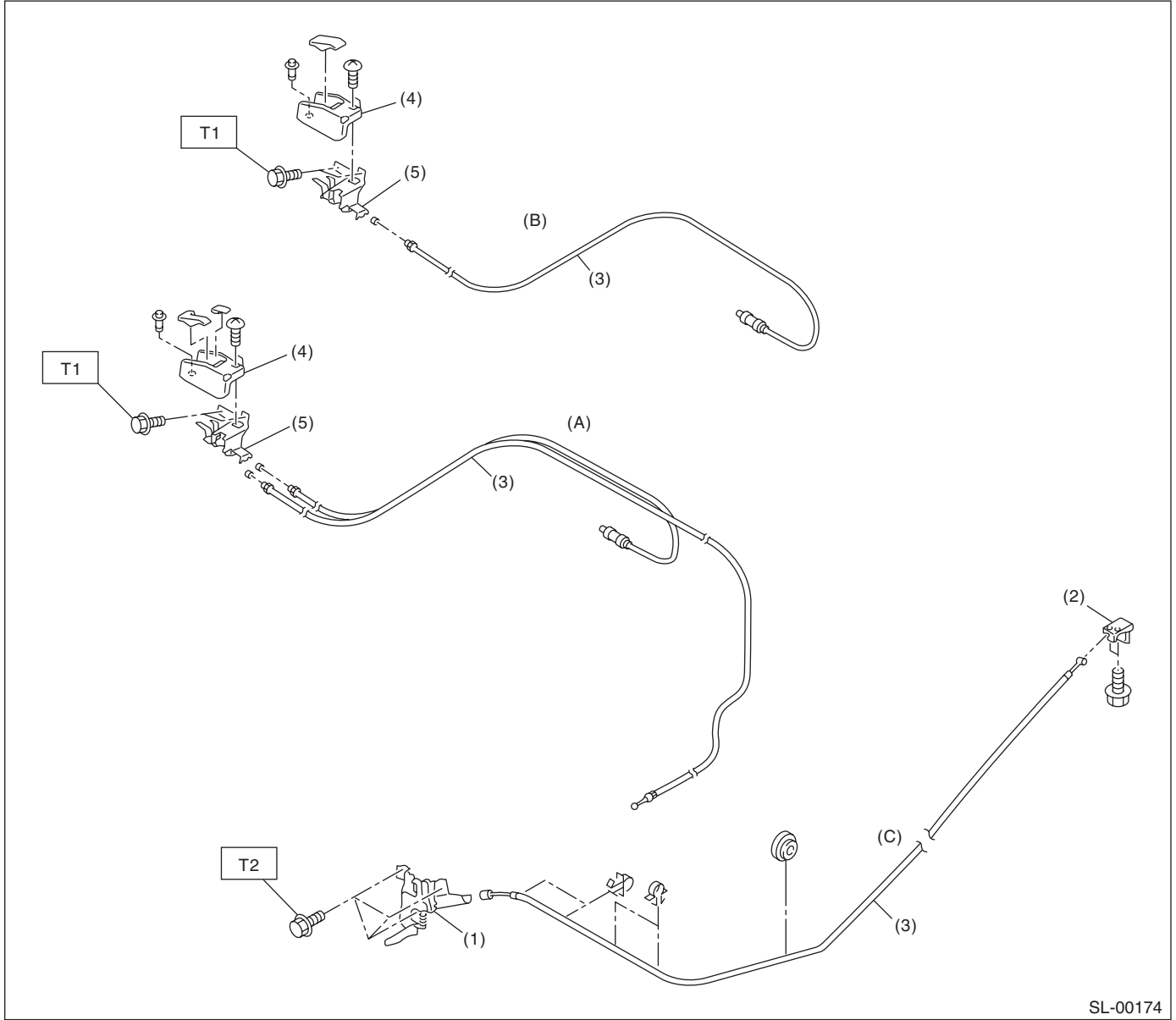

(A) Sedan

(B) Wagon

(C) Hood

(1) Hood lock ASSY

(4) Cover

Tightening torque: N·m (kgf·m, ft·lb)

(2) Lever ASSY

(5) Pull handle ASSY

T1: 6.5 (0.66, 4.7)

(3) Cable

T2: 32 (3.3, 23.9)

4. KEYLESS ENTRY SYSTEM

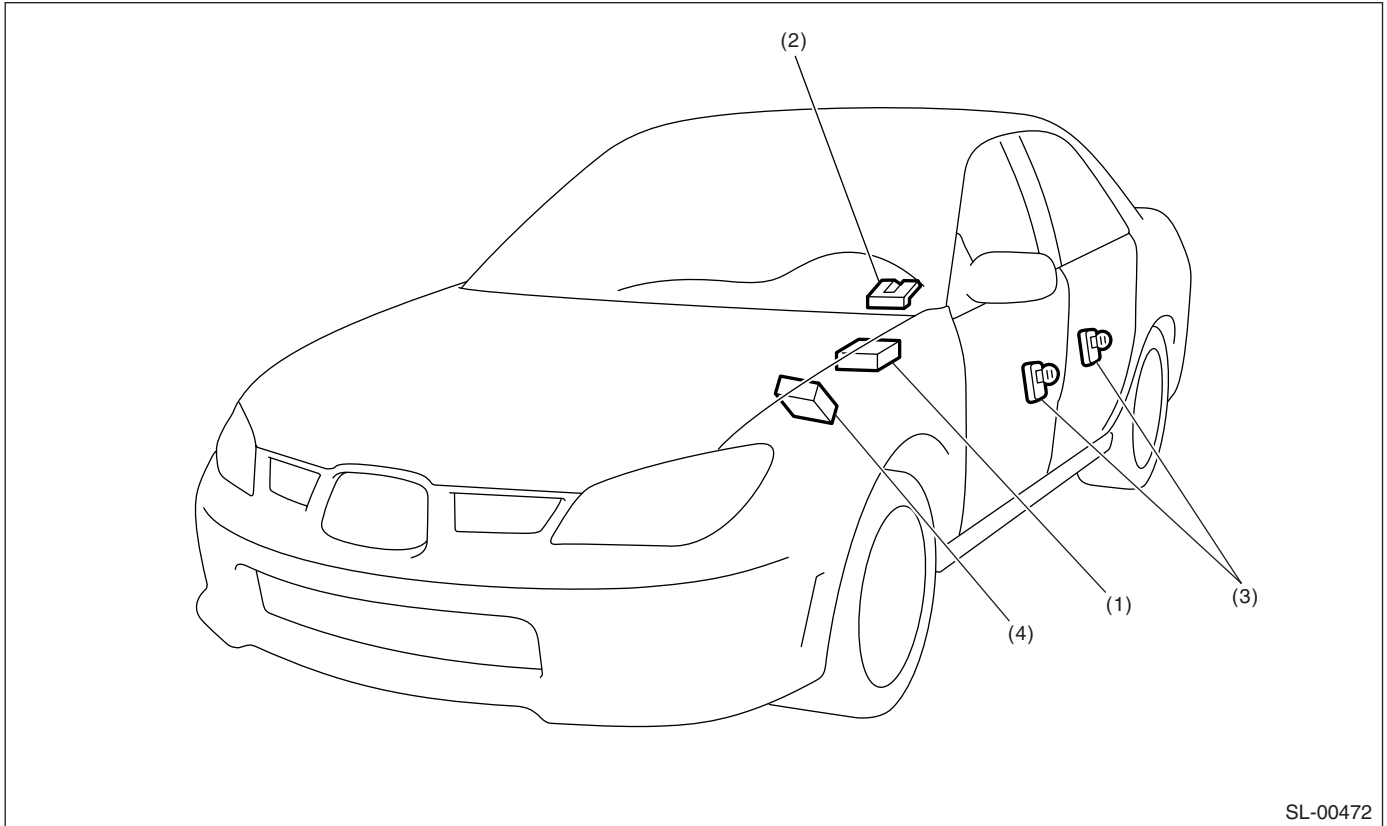

SL-00472

- (1) Keyless entry control unit
- (2) Rear gate latch (Wagon model)
- (3) Door switch
- (4) Body integrated module

5. IMMOBILIZER SYSTEM

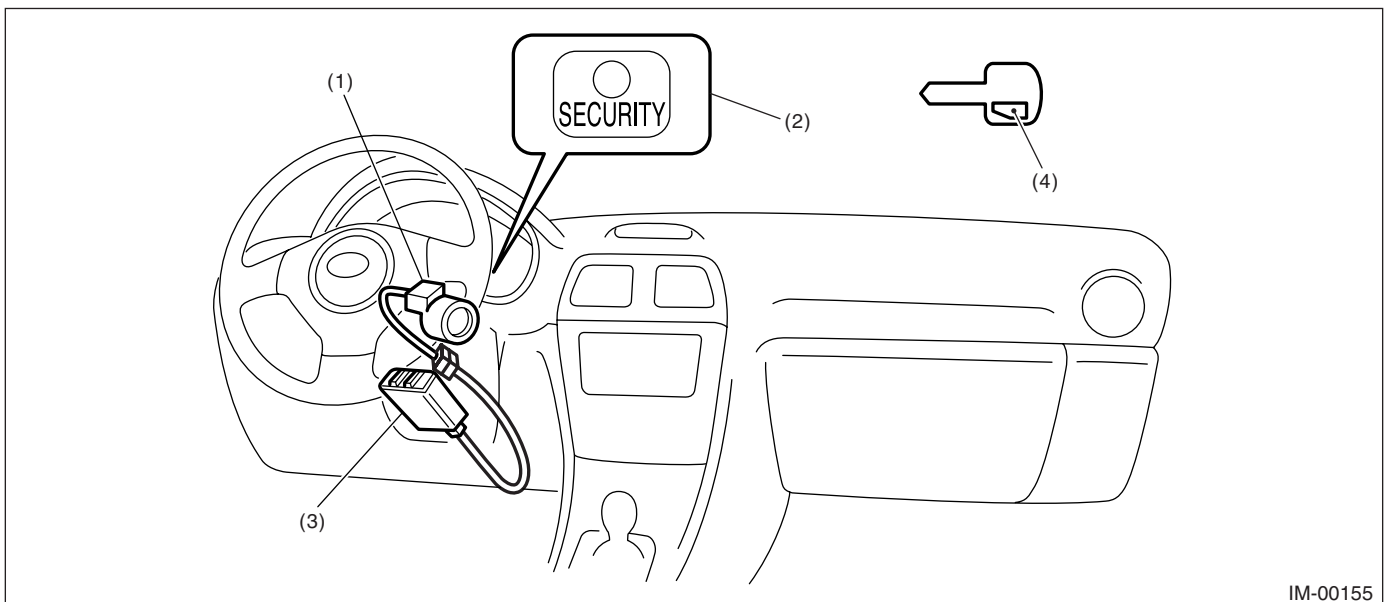

IM-00155

- (1) Antenna
- (2) Security indicator light (LED bulb)
- (3) Immobilizer control module (IMM ECM)
- (4) Transponder

General Description

SECURITY AND LOCKS

6. SECURITY SYSTEM

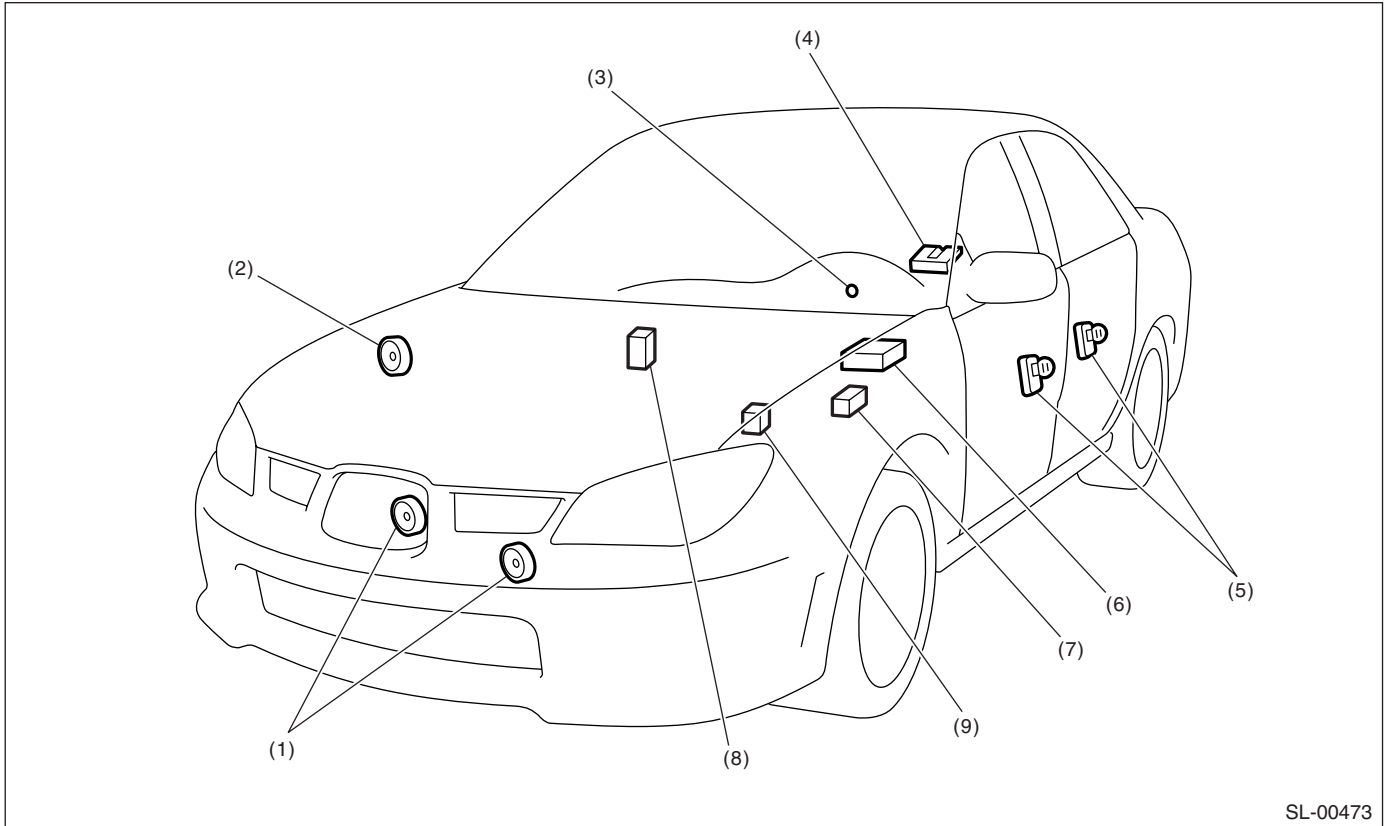

- | | | |
|---|---|-----------------------------------|
| (1) Horn | (4) Trunk room light switch (Sedan model), rear gate latch switch (Wagon model) | (6) Keyless entry control unit |
| (2) Security horn | (5) Door switch | (7) Security horn relay |
| (3) Security indicator light (in combination meter) | | (8) Interrupt relay |
| | | (9) Horn relay (in main fuse box) |

B: CAUTION

- Before disassembling or reassembling parts, always disconnect the ground cable from battery. When repairing audio, control module, etc. which are provided with memory functions, record the memory contents before disconnecting the ground cable from battery. Otherwise, these contents are cancelled upon disconnection.
- Reassemble parts in the reverse order of disassembly procedure unless otherwise indicated.
- Adjust parts to the specifications contained in this manual if so designated.

- Connect the connectors securely during reassembly.
- After reassembly, ensure all functional parts operate smoothly.
- Airbag system wiring harness is routed near the electrical parts and switch.
- Airbag system connectors are colored yellow. Do not use electrical test equipment on these circuits.
- Be careful not to damage the airbag system wiring harness when servicing the ignition key cylinder.

C: PREPARATION TOOL

1. SPECIAL TOOL

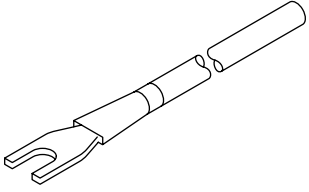
ILLUSTRATION	TOOL NUMBER	DESCRIPTION	REMARKS
 ST-925580000	925580000	PULLER	Used for removing trim clip.

2. GENERAL TOOL

TOOL NAME	REMARKS
Circuit tester	Used for measuring resistance and voltage.
Drill	Used for replacing ignition key lock.

Door Lock Control System

SECURITY AND LOCKS

2. Door Lock Control System

A: WIRING DIAGRAM

1. DOOR LOCK CONTROL

<Ref. to WI-166, WIRING DIAGRAM, Keyless Entry System.>

B: INSPECTION

1. SYMPTOM CHART

Symptom	Repair order	Reference
The door lock control system does not operate.	1. Check the fuse.	<Ref. to SL-8, CHECK FUSE, INSPECTION, Door Lock Control System.>
	2. Check the power supply and ground circuit for the body integrated module.	<Ref. to SL-9, CHECK POWER SUPPLY AND GROUND CIRCUIT, INSPECTION, Door Lock Control System.>
	3. Check the door lock switch and the circuit.	<Ref. to SL-9, CHECK DOOR LOCK SWITCH AND CIRCUIT, INSPECTION, Door Lock Control System.>
	4. Check the door lock actuator and the circuit.	<Ref. to SL-10, CHECK DOOR LOCK ACTUATOR AND CIRCUIT, INSPECTION, Door Lock Control System.>
The door lock switch does not operate.	Check the door lock switch and the circuit.	<Ref. to SL-9, CHECK DOOR LOCK SWITCH AND CIRCUIT, INSPECTION, Door Lock Control System.>
A specific door lock actuator does not operate.	Check the door lock actuator and the circuit.	<Ref. to SL-10, CHECK DOOR LOCK ACTUATOR AND CIRCUIT, INSPECTION, Door Lock Control System.>

2. CHECK FUSE

Step	Check	Yes	No
1 CHECK FUSE. Remove and visually check the fuses No. 2 (in the main fuse box) No. 3 (in fuse & relay box).	Is the fuse blown out?	Replace the fuse with a new one.	Check the power supply and ground circuit. <Ref. to SL-9, CHECK POWER SUPPLY AND GROUND CIRCUIT, INSPECTION, Door Lock Control System.>

3. CHECK POWER SUPPLY AND GROUND CIRCUIT

Step	Check	Yes	No	
1	CHECK POWER SUPPLY. 1) Disconnect the body integrated module harness connector. 2) Measure the voltage between the harness connector terminal and chassis ground. <i>Connector & terminal</i> <i>(B280) No. 2 (+) — Chassis ground (-):</i>	Is the voltage more than 10 V?	Go to step 2.	Check the harness for open circuits or shorts between the body integrated module and the fuse.
2	CHECK GROUND CIRCUIT. Measure the resistance between the harness connector terminal and chassis ground. <i>Connector & terminal</i> <i>(B280) No. 4, 13 — Chassis ground:</i>	Is the resistance less than 10 Ω ?	The power supply and ground circuit is OK.	Repair the harness.

4. CHECK DOOR LOCK SWITCH AND CIRCUIT

Step	Check	Yes	No	
1	CHECK DOOR LOCK SWITCH CIRCUIT. 1) Disconnect the body integrated module harness connector. 2) Measure the resistance between the harness connector terminal and chassis ground when moving the door lock switch to LOCK. <i>Connector & terminal</i> <i>(B281) No. 12 — Chassis ground:</i>	Is the resistance less than 10 Ω ?	Go to step 2.	Go to step 3.
2	CHECK DOOR LOCK SWITCH CIRCUIT. Measure the resistance between the harness connector terminal and chassis ground when the door lock switch is moved to UNLOCK. <i>Connector & terminal</i> <i>(B281) No. 11 — Chassis ground:</i>	Is the resistance less than 10 Ω ?	The door lock switch is OK.	Go to step 3.
3	CHECK DOOR LOCK SWITCH. 1) Disconnect the door lock switch harness connector. 2) Measure the resistance between the door lock switch terminals when moving the door lock switch to LOCK. <i>Connector & terminal</i> <i>Driver's side:</i> <i>(D7) No. 5 — No. 9</i> <i>Passenger's side:</i> <i>(D62) No. 4 — No. 5</i>	Is the resistance less than 10 Ω ?	Go to step 4.	Replace the door lock switch.
4	CHECK DOOR LOCK SWITCH. Measure the resistance between the door lock switch terminals when moving the door lock switch to UNLOCK. <i>Connector & terminal</i> <i>Driver's side:</i> <i>(D7) No. 5 — No. 8</i> <i>Passenger's side:</i> <i>(D62) No. 2 — No. 5</i>	Is the resistance less than 1 Ω ?	Check the harness for open circuits or shorts between the body integrated module and the door lock switch.	Replace the door lock switch.

Door Lock Control System

SECURITY AND LOCKS

5. CHECK DOOR LOCK ACTUATOR AND CIRCUIT

Step	Check	Yes	No
1 CHECK OUTPUT SIGNAL. Measure the voltage between the harness connector terminal of body integrated module and chassis ground when moving the door lock switch to LOCK. <i>Connector & terminal</i> <i>(B280) No. 6 (+) — Chassis ground (-):</i>	Is the voltage more than 10 V?	Go to step 2.	Replace the body integrated module.
2 CHECK OUTPUT SIGNAL. Measure the voltage between the harness connector terminal of body integrated module and chassis ground when moving the door lock switch to UNLOCK. <i>Connector & terminal</i> <i>(B280) No. 7, 8 (+) — Chassis ground (-):</i>	Is the voltage more than 10 V?	Go to step 3.	Replace the body integrated module.
3 CHECK DOOR LOCK ACTUATOR. Check the door lock actuator. Front door lock actuator: <Ref. to SL-32, Front Door Lock Actuator.> Rear door lock actuator: <Ref. to SL-36, Rear Door Lock Actuator.> Rear gate latch lock actuator: <Ref. to SL-39, Rear Gate Latch Lock Actuator.>	Is the door lock actuator OK?	Check the harness for open circuits or shorts between the body integrated module and the door lock actuator.	Replace the door lock actuator.

3. Keyless Entry System

A: WIRING DIAGRAM

1. KEYLESS ENTRY

<Ref. to WI-166, WIRING DIAGRAM, Keyless Entry System.>

B: ELECTRICAL SPECIFICATION

1. KEYLESS ENTRY CONTROL UNIT

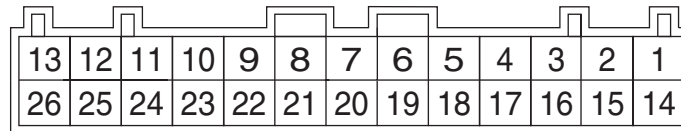

SL-00478

Content	Terminal No.	Measuring condition
Turn signal light (Left)	1 (OUTPUT)	Battery voltage is present when pressing the transmitter UNLOCK/DISARM or LOCK/ARM button.
Power supply (Backup)	2	Battery voltage is constantly present.
Keyless buzzer	3 (OUTPUT)	0 V is present when pressing the transmitter UNLOCK/DISARM or LOCK/ARM button.
Door unlock switch	4 (INPUT)	0 V is present when operating the door lock switch.
Door lock switch	5 (INPUT)	0 V is present when operating the door lock switch.
Door switch and rear gate latch switch	6 (INPUT)	0 V is present when any door or rear gate is open.
Trunk latch switch	7 (INPUT)	0 V is present when trunk is open.
Key warning switch	9 (INPUT)	Battery voltage is present when inserting the key into the ignition switch.
Ignition switch (ON)	10 (INPUT)	Battery voltage is present when ignition switch is turned to ON.
Turn signal light (Right)	13 (OUTPUT)	Battery voltage is present when pressing the transmitter UNLOCK/DISARM or LOCK/ARM button.
Ground	14	0 V is constantly present.
Body integrated module	18 (OUTPUT)	Battery voltage is present when pressing the transmitter UNLOCK/DISARM button.
Body integrated module	19 (OUTPUT)	Battery voltage is present when pressing the transmitter LOCK/ARM button.
Horn relay	24 (OUTPUT)	0 V is present when pressing the transmitter LOCK/ARM button three times within 5 seconds.
Power supply (Backup)	26	Battery voltage is constantly present.

Keyless Entry System

SECURITY AND LOCKS

2. BODY INTEGRATED MODULE

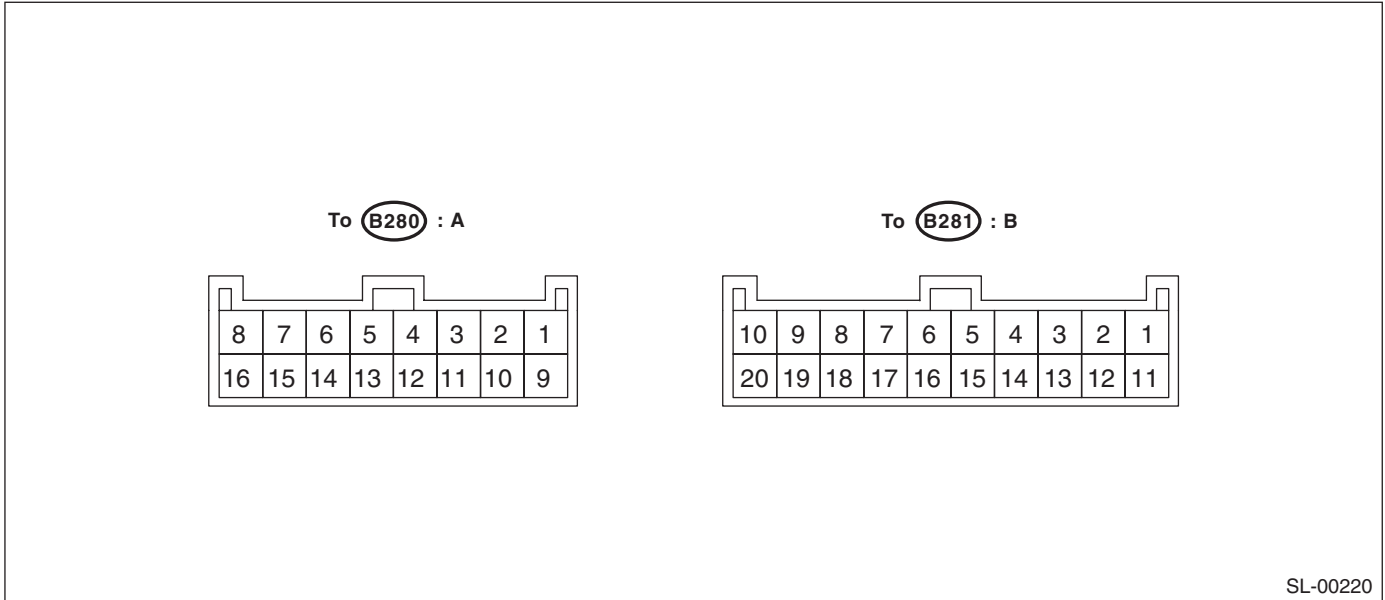

Content	Terminal No.	Measuring condition
Door switch (Except driver's door)	B7 (INPUT)	0 V is present when any door is open (Except driver's door).
Door switch (Driver's door)	B8 (INPUT)	0 V is present when driver's door is open.
Door unlock switch	B11 (INPUT)	0 V is present when operating the door unlock switch.
Door lock switch	B12 (INPUT)	0 V is present when operating the door lock switch.
Keyless entry control unit	B13 (INPUT)	Battery voltage is present when pressing the transmitter LOCK/ARM button.
Keyless entry control unit	B14 (INPUT)	Battery voltage is present when pressing the transmitter UNLOCK/DISARM button.
Ignition switch (ON)	B19 (INPUT)	Battery voltage is present when ignition switch is turned to ON.
Key warning switch	B20 (INPUT)	Battery voltage is present when inserting the key into the ignition switch.
Power supply	A2	Battery voltage is constantly present.
Ground	A4	0 V is constantly present.
Room light	A5 (OUTPUT)	0 V is present when pressing the transmitter UNLOCK/DISARM button.
Door and rear gate lock actuator	A6 (OUTPUT)	Battery voltage is present when pressing the transmitter LOCK/ARM button.
Door and rear gate lock actuator (Except driver side)	A7 (OUTPUT)	Battery voltage is present when pressing the transmitter UNLOCK/DISARM button two times.
Door lock actuator (Driver side)	A8 (OUTPUT)	Battery voltage is present when pressing the transmitter UNLOCK/DISARM button once.
Ground	A13	0 V is constantly present.

C: INSPECTION

1. SYMPTOM CHART

Symptom	Repair order	Reference
None of the functions of the keyless entry system operate.	1. Check the transmitter battery and function.	<Ref. to SL-15, CHECK TRANSMITTER BATTERY AND FUNCTION, INSPECTION, Keyless Entry System.>
	2. Check the fuse.	<Ref. to SL-16, CHECK FUSE, INSPECTION, Keyless Entry System.>
	3. Check the keyless entry control unit power supply and ground circuit.	<Ref. to SL-17, CHECK POWER SUPPLY AND GROUND CIRCUIT, INSPECTION, Keyless Entry System.>
	4. Replace the keyless entry control unit.	<Ref. to SL-55, Keyless Entry Control Unit.>
The transmitter cannot be registered.	1. Check the transmitter battery and function.	<Ref. to SL-15, CHECK TRANSMITTER BATTERY AND FUNCTION, INSPECTION, Keyless Entry System.>
	2. Check the ignition switch circuit.	<Ref. to SL-17, CHECK IGNITION SWITCH CIRCUIT, INSPECTION, Keyless Entry System.>
	3. Check the door switch.	<Ref. to SL-17, CHECK DOOR SWITCH, INSPECTION, Keyless Entry System.>
	4. Replace the keyless entry control unit.	<Ref. to SL-55, Keyless Entry Control Unit.>
The door lock or unlock does not operate. NOTE: If the door lock control system does not operate when using the door lock switch, check the door lock control system. <Ref. to SL-8, INSPECTION, Door Lock Control System.>	1. Check the transmitter battery and function.	<Ref. to SL-15, CHECK TRANSMITTER BATTERY AND FUNCTION, INSPECTION, Keyless Entry System.>
	2. Check the key warning switch.	<Ref. to SL-18, CHECK KEY WARNING SWITCH, INSPECTION, Keyless Entry System.>
	3. Check the door switch.	<Ref. to SL-17, CHECK DOOR SWITCH, INSPECTION, Keyless Entry System.>
	4. Check the output signal to body integrated module.	<Ref. to SL-19, CHECK OUTPUT SIGNAL TO BODY INTEGRATED MODULE, INSPECTION, Keyless Entry System.>
	5. Replace the keyless entry control unit.	<Ref. to SL-55, Keyless Entry Control Unit.>
The panic alarm does not operate.	1. Check the transmitter battery and function.	<Ref. to SL-15, CHECK TRANSMITTER BATTERY AND FUNCTION, INSPECTION, Keyless Entry System.>
	2. Check the horn operation.	<Ref. to SL-20, CHECK HORN OPERATION, INSPECTION, Keyless Entry System.>
	3. Replace the keyless entry control unit.	<Ref. to SL-55, Keyless Entry Control Unit.>

Keyless Entry System

SECURITY AND LOCKS

Symptom	Repair order		Reference
The buzzer chirp and hazard light do not operate.	1. Check the buzzer chirp function.		<Ref. to SL-16, CHECK BUZZER CHIRP SETTING, INSPECTION, Keyless Entry System.>
	2. Check the buzzer and hazard light operation.	Buzzer	<Ref. to SL-20, CHECK KEYLESS BUZZER, INSPECTION, Keyless Entry System.>
		Hazard light	<Ref. to SL-20, CHECK HAZARD LIGHT OPERATION, INSPECTION, Keyless Entry System.>
	3. Replace the keyless entry control unit.		<Ref. to SL-55, Keyless Entry Control Unit.>
The room light operation do not activate.	1. Check the room light operation.		<Ref. to SL-19, CHECK ROOM LIGHT OPERATION, INSPECTION, Keyless Entry System.>
	2. Replace the keyless entry control unit.		<Ref. to SL-55, Keyless Entry Control Unit.>
The door warning does not operate.	1. Check the door switch.		<Ref. to SL-17, CHECK DOOR SWITCH, INSPECTION, Keyless Entry System.>
	2. Check the buzzer operation.		<Ref. to SL-20, CHECK KEYLESS BUZZER, INSPECTION, Keyless Entry System.>
	3. Replace the keyless entry control unit.		<Ref. to SL-55, Keyless Entry Control Unit.>

2. CHECK TRANSMITTER BATTERY AND FUNCTION

Step	Check	Yes	No
1 CHECK TRANSMITTER BATTERY. 1) Remove the battery from the transmitter. <Ref. to SL-57, REMOVAL, Transmitter.> 2) Check the battery voltage. <Ref. to SL-57, INSPECTION, Transmitter.>	Is the voltage more than 2.5 V?	Go to step 2.	Replace the transmitter battery. <Ref. to SL-57, Transmitter.>
2 CHECK TRANSMITTER. Register the transmitter which operates normally on other vehicles to inspection target vehicle. <Ref. to SL-57, REGISTRATION OF TRANSMITTER WITH SUBARU SELECT MONITOR, REPLACEMENT, Transmitter.> 1) Close all the doors and rear gate of inspection target vehicle. 2) Using transmitter, lock and unlock the doors and rear gate of inspection target vehicle.	Is the inspection target vehicle operates lock and unlock normally?	Go to step 3.	Due to vehicle malfunction, continue the keyless entry system diagnosis.
3 CHECK TRANSMITTER. Register the transmitter of inspection target vehicle to the other vehicle which operates keyless system normally. <Ref. to SL-57, REGISTRATION OF TRANSMITTER WITH SUBARU SELECT MONITOR, REPLACEMENT, Transmitter.>	Is the transmitter registered correctly?	Go to step 4.	Replace the transmitter. <Ref. to SL-57, REGISTRATION OF TRANSMITTER WITH SUBARU SELECT MONITOR, REPLACEMENT, Transmitter.>
4 CHECK TRANSMITTER. Check the registered transmitter. 1) Close all the doors and rear gate of the vehicle which operates keyless system normally. 2) Using transmitter, lock and unlock the doors and rear gate of inspection target vehicle.	Is the vehicle operates lock and unlock normally?	The transmitter is normal.	Replace the transmitter. <Ref. to SL-57, REGISTRATION OF TRANSMITTER WITH SUBARU SELECT MONITOR, REPLACEMENT, Transmitter.>

CAUTION:

Be sure to reset the transmitter, which is registered from other vehicle to inspection target vehicle, and the vehicle, to which is registered transmitter, to the condition of before inspection. (Register the transmitter to original condition.)

Keyless Entry System

SECURITY AND LOCKS

3. CHECK BUZZER CHIRP SETTING

Step	Check	Yes	No
1 CHECK BUZZER CHIRP SETTING. 1) Check the current setting of the buzzer chirp. 2) Remove the key from the ignition switch. 3) Close all doors and the rear gate. 4) Press the LOCK/ARM or UNLOCK/DIS-ARM button.	Does the buzzer signal chirp?	Buzzer chirp function is OK.	Go to step 2.
2 CHECK BUZZER CHIRP SETTING. 1) Open the driver's door, and remove the key from the ignition switch. 2) Insert the key into ignition switch with the manual UNLOCK switch on vehicle side turned to ON. 3) Repeat the procedure of removing → inserting the key five times within 10 seconds from step 2). 4) Perform opening → closing the door within 5 seconds from the fifth procedure in step 3). 5) Switch the setting (ON ↔ OFF) of answer back buzzer. The hazard light will blink three times. NOTE: If not performing opening → closing the door within 10 seconds, the hazard light will blink once. In that case, perform the procedure from the beginning again. 6) Press the LOCK/ARM or UNLOCK/DIS-ARM button.	Does the buzzer signal chirp?	Buzzer chirp function is OK.	Check the transmitter function. <Ref. to SL-15, CHECK TRANSMITTER BATTERY AND FUNCTION, INSPECTION, Keyless Entry System.>

4. CHECK FUSE

Step	Check	Yes	No
1 CHECK FUSE. Remove and visually check the fuse No. 6 (in the main fuse box) and No. 3 (in the fuse and relay box).	Is the fuse blown out?	Replace the fuse with a new one.	Check the power supply and ground circuit. <Ref. to SL-17, CHECK POWER SUPPLY AND GROUND CIRCUIT, INSPECTION, Keyless Entry System.>

5. CHECK POWER SUPPLY AND GROUND CIRCUIT

Step	Check	Yes	No
1 CHECK POWER SUPPLY. 1) Disconnect the keyless entry control unit harness connector. 2) Measure the voltage between the harness connector terminal and chassis ground. <i>Connector & terminal</i> <i>(B176) No. 2, 26 (+) — Chassis ground (-):</i>	Is the voltage more than 10 V?	Go to step 2.	Check the harness for open circuits and shorts between the keyless entry control unit and fuse.
2 CHECK GROUND CIRCUIT. Measure the resistance between the harness connector terminal and chassis ground. <i>Connector & terminal</i> <i>(B176) No. 14 — Chassis ground:</i>	Is the resistance less than 10 Ω ?	The power supply and ground circuit are OK.	Repair the harness.

6. CHECK IGNITION SWITCH CIRCUIT

Step	Check	Yes	No
1 CHECK IGNITION SWITCH SIGNAL. 1) Disconnect the keyless entry control unit harness connector. 2) Turn the ignition switch to ON. 3) Measure the voltage between harness connector terminal and chassis ground. <i>Connector & terminal</i> <i>(B176) No. 10 (+) — Chassis ground (-):</i>	Is the voltage more than 10 V?	Ignition switch circuit is OK.	Check the harness for open circuits and shorts between the keyless entry control unit and ignition relay.

7. CHECK DOOR SWITCH

Step	Check	Yes	No
1 CHECK DOOR SWITCH CIRCUIT. Measure the voltage between the keyless entry control unit harness connector terminal and chassis ground. <i>Connector & terminal</i> <i>Front and rear side door:</i> <i>(B176) No. 6 (+) — Chassis ground (-):</i> <i>Rear gate:</i> <i>(B176) No. 7 (+) — Chassis ground (-):</i>	Is the voltage 0 V when each door or rear gate is opened?	Go to step 2.	Go to step 3.
2 CHECK DOOR SWITCH CIRCUIT. Measure the voltage between the keyless entry control unit harness connector terminal and chassis ground. <i>Connector & terminal</i> <i>Front and rear side door:</i> <i>(B176) No. 6 (+) — Chassis ground (-):</i> <i>Rear gate:</i> <i>(B176) No. 7 (+) — Chassis ground (-):</i>	Is the voltage more than 10 V when each door or rear gate is closed?	The door switch is OK.	Go to step 3.
3 CHECK DOOR SWITCH. 1) Disconnect the door switch harness connector. 2) Measure the resistance between the door switch terminals. <i>Terminals</i> <i>Door switch No. 1 — No. 3:</i> <i>Rear gate latch switch No. 1 — No. 2:</i>	Is the resistance more than 1 M Ω when the door switch is depressed?	Go to step 4.	Replace the door switch.

Keyless Entry System

SECURITY AND LOCKS

Step	Check	Yes	No
4 CHECK DOOR SWITCH. Measure the resistance between the door switch terminals. <i>Terminals</i> <i>Door switch No. 1 — No. 3:</i> <i>Rear gate latch switch No. 1 — No. 2:</i>	Is the resistance less than 1 Ω when the door switch is released?	Check the harness for open circuits and shorts between the body integrated module and door switch.	Replace the door switch.

8. CHECK KEY WARNING SWITCH

Step	Check	Yes	No
1 CHECK FUSE. Remove and visually check the fuse No. 6 (in the main fuse box).	Is the fuse blown out?	Replace the fuse with a new one.	Go to step 2.
2 CHECK KEY WARNING SWITCH CIRCUIT. 1) Disconnect the keyless entry control unit harness connector. 2) Insert the key into the ignition switch. (LOCK position) 3) Measure the voltage between the harness connector terminal and chassis ground. <i>Connector & terminal</i> <i>(B176) No. 9 (+) — Chassis ground (-):</i>	Is the voltage more than 10 V?	Go to step 3.	Go to step 4.
3 CHECK KEY WARNING SWITCH CIRCUIT. 1) Remove the key from the ignition switch. 2) Measure the voltage between the harness connector terminal and chassis ground. <i>Connector & terminal</i> <i>(B176) No. 9 (+) — Chassis ground (-):</i>	Is the voltage 0 V?	Key warning switch is OK.	Go to step 4.
4 CHECK KEY WARNING SWITCH. 1) Disconnect the key warning switch harness connector. 2) Insert the key into the ignition switch. (LOCK position) 3) Measure the resistance between the key warning switch terminals. <i>Terminals</i> <i>No. 1 — No. 2:</i>	Is the resistance less than 1 Ω ?	Go to step 5.	Replace the key warning switch.
5 CHECK KEY WARNING SWITCH. 1) Remove the key from the ignition switch. 2) Measure the resistance between the key warning switch terminals. <i>Terminals</i> <i>No. 1 — No. 2:</i>	Is the resistance more than 1 M Ω ?	Check the following: <ul style="list-style-type: none"> • Harness for open circuits and shorts between the key warning switch and fuse • Harness for open circuits and shorts between the keyless entry control unit and key warning switch 	Replace the key warning switch.

9. CHECK ROOM LIGHT OPERATION

Step	Check	Yes	No
1 CHECK ROOM LIGHT OPERATION. Make sure the room light illuminates when the room light switch is turned ON.	Does the room light illuminate?	Go to step 2.	Check the room light circuit.
2 CHECK HARNESS BETWEEN ROOM LIGHT AND BODY INTEGRATED MODULE. 1) Disconnect the body integrated module harness connector and room light harness connector. 2) Measure the resistance between the body integrated module harness connector terminal and the room light harness connector terminal. <i>Connector & terminal</i> <i>(B280) No. 5 — (R52) No. 2:</i>	Is the resistance less than 10 Ω ?	The room light operation circuit is OK.	Check the harness for open circuits and/or shorts between the body integrated module and room light.

10. CHECK OUTPUT SIGNAL TO BODY INTEGRATED MODULE

Step	Check	Yes	No
1 CHECK OUTPUT SIGNAL. Measure the voltage between the keyless entry control unit harness connector terminal and chassis ground when UNLOCK/DISARM button of transmitter is pressed. <i>Connector & terminal</i> <i>(B176) No. 18 (+) — Chassis ground (-):</i>	Is the voltage more than 10 V?	Go to step 2.	Replace the keyless entry control unit.
2 CHECK OUTPUT SIGNAL. Measure the voltage between the keyless entry control unit harness connector terminal and chassis ground when LOCK/ARM button of transmitter is pressed. <i>Connector & terminal</i> <i>(B176) No. 19 (+) — Chassis ground (-):</i>	Is the voltage more than 10 V?	Go to step 3.	Replace the keyless entry control unit.
3 CHECK HARNESS BETWEEN KEYLESS ENTRY CONTROL UNIT AND BODY INTEGRATED MODULE. 1) Disconnect the keyless entry control unit harness connector and body integrated module harness connector. 2) Measure the resistance between the keyless entry control unit harness connector terminal and body integrated module harness connector terminal. <i>Connector & terminal</i> <i>(B176) No. 18 — (B281) No. 14:</i> <i>(B176) No. 19 — (B281) No. 13:</i>	Is the resistance less than 10 Ω ?	Replace the body integrated module.	Check the harness for open circuit or shorts between the keyless entry control unit and body integrated module.

Keyless Entry System

SECURITY AND LOCKS

11.CHECK HORN OPERATION

Step	Check	Yes	No
1 CHECK HORN OPERATION Make sure the horn sounds when the horn switch is pushed.	Does the horn sound?	Go to step 2.	Check the horn circuit.
2 CHECK HORN OPERATION 1) Disconnect the keyless entry control unit harness connector. 2) Ground the harness connector terminal with a suitable wire. Connector & terminal (B176) No. 24 — Chassis ground:	Does the horn sound?	Replace the keyless entry control unit.	Check the harness for open circuits and/or shorts between the keyless entry control unit and horn relay.

12.CHECK HAZARD LIGHT OPERATION

Step	Check	Yes	No
1 CHECK HAZARD LIGHT OPERATION. Make sure the hazard light blinks when hazard switch is turned ON.	Does the hazard light blink?	Go to step 2.	Check the hazard light circuit.
2 CHECK OUTPUT SIGNAL. 1) Remove the key from ignition switch. 2) Close all doors and rear gate. 3) Measure the voltage between keyless entry control unit harness connector terminal and chassis ground when LOCK/ARM button of transmitter is pressed. Connector & terminal (B176) No. 1, 13 (+) — Chassis ground (-):	Is the voltage more than 10 V?	Check the harness for open or short between keyless entry control unit and turn signal lights.	Replace the keyless entry control unit.

13.CHECK KEYLESS BUZZER

Step	Check	Yes	No
1 CHECK FUSE. Remove and check the fuse No. 2 (located in main fuse box).	Is the fuse blown out?	Replace the fuse with a new one.	Go to step 2.
2 CHECK KEYLESS POWER SUPPLY. 1) Disconnect the connector from keyless buzzer. 2) Measure the voltage between keyless buzzer harness connector and chassis ground. Connector & terminal (F102) No. 2 (+) — Chassis ground (-):	Is the voltage more than 10 V?	Go to step 3.	Check the harness for open or short between fuse and keyless buzzer.
3 CHECK HARNESS BETWEEN KEYLESS BUZZER AND KEYLESS ENTRY CONTROL UNIT. 1) Disconnect the connector from keyless entry control unit. 2) Measure the resistance between keyless buzzer and keyless entry control unit. Connector & terminal (F102) No. 1 — (B176) No. 3:	Is the resistance less than 10 Ω ?	Go to step 4.	Repair the harness between keyless buzzer and keyless entry control unit.
4 CHECK KEYLESS BUZZER. Make sure that the buzzer sounds when connecting battery positive lead to No. 2 terminal of keyless buzzer connector and battery ground lead to No. 1 terminal of keyless buzzer connector.	Does the buzzer sound?	Replace the keyless entry control unit.	Replace the keyless buzzer.

4. Security System

A: WIRING DIAGRAM

<Ref. to WI-169, WIRING DIAGRAM, Security System.>

B: ELECTRICAL SPECIFICATION

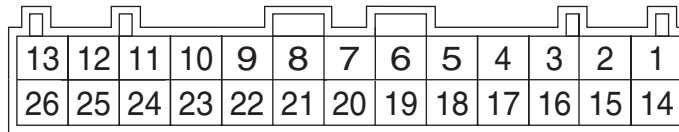

SL-00478

Content	Terminal No.	Measuring condition
Power supply (Backup)	2	Battery voltage is constantly present.
Door switch	6 (INPUT)	0 V is present when any door is open.
Trunk room light switch (Sedan model)	7 (INPUT)	0 V is present when trunk lid or rear gate is open.
Rear gate latch switch (Wagon model)		
Impact sensor	8	—
Ignition switch (ON)	10 (INPUT)	Battery voltage is present when ignition switch is turned to ON.
Security horn relay	11 (INPUT)	Battery voltage is present when activating the alarm operation.
Interrupt relay	12 (OUTPUT)	Battery voltage is present when activating the alarm operation.
Ground	14	0 V is constantly present.
Impact sensor	15	—
Security indicator light	15 (OUTPUT)	0 V is present when activating the alarm operation.
Impact sensor	17	—

Security System

SECURITY AND LOCKS

C: INSPECTION

1. BASIC DIAGNOSTIC PROCEDURE

NOTE:

- Turbo model has immobilizer.
- Non-turbo model has no immobilizer.

Step	Check	Yes	No
1 SET SECURITY SYSTEM. Set the security system to ON. <Ref. to SL-24, SYMPTOM CHART, INSPECTION, Security System.>	Is the setting completed correctly?	Go to step 2.	<ul style="list-style-type: none"> • Check the ignition switch circuit. <Ref. to SL-28, CHECK IGNITION SWITCH CIRCUIT, INSPECTION, Security System.> • Check the door lock switch. <Ref. to SL-9, CHECK DOOR LOCK SWITCH AND CIRCUIT, INSPECTION, Door Lock Control System.>
2 CHECK FOR OPERATION OF SECURITY SYSTEM SETTING. 1) Before starting this diagnosis, open all doors. 2) Remove the key from ignition key cylinder, and then close all doors or rear gate. 3) Press the LOCK/ARM button of transmitter.	Can the security system be set?	Go to step 3.	Go to symptom 1. <Ref. to SL-24, SYMPTOM CHART, INSPECTION, Security System.>
3 CHECK FOR STATUS OF BLINKING OF SECURITY INDICATOR LIGHT AND HAZARD LIGHT Check for the status of blinking of security indicator light and hazard light. NOTE: For model with immobilizer, the light blinks 2 times, for model without immobilizer, it blinks once.	Do the security indicator light and hazard light blink?	Go to step 4.	Go to symptom 2. <Ref. to SL-24, SYMPTOM CHART, INSPECTION, Security System.>
4 CHECK SECURITY SYSTEM OPERATION. Press the LOCK button of transmitter, and wait for 30 seconds.	Is the blinking pattern of security indicator light blink twice within 0.5 second in 2 seconds cycle?	Go to step 5.	Replace the keyless control unit.
5 CHECK SECURITY ALARM OPERATION. 1) Unlock all doors using the door lock switch on front door. 2) Open any door or rear gate.	Does the security alarm operate when opening any door or rear gate?	Go to step 6.	Go to symptom 3. <Ref. to SL-24, SYMPTOM CHART, INSPECTION, Security System.>
6 CHECK SECURITY ALARM OPERATION. Check the security alarm operation.	Does the all security alarm (horn, hazard light and security indicator light) operate, and is the starter motor stopped?	Go to step 7.	Go to symptom 4. <Ref. to SL-24, SYMPTOM CHART, INSPECTION, Security System.>

Step	Check	Yes	No
7 CHECK SECURITY ALARM CANCEL OPERATION. Press the UNLOCK/DISARM button of transmitter. NOTE: For model with immobilizer, the light blinks once, for model without immobilizer, it remains off.	Does the all security alarm (horn and hazard light) stop, and is the starter motor operated?	Go to step 8.	Go to symptom 5. <Ref. to SL-24, SYMPTOM CHART, INSPECTION, Security System.>
8 CHECK BATTERY OPEN PROTECTION FUNCTION Check the system function properly when the battery is not connected temporarily. <Ref. to SL-23, CHECK BATTERY DISCONNECT PROTECTION, INSPECTION, Security System.>	Does the system function properly when the battery is not connected temporarily?	Go to step 9.	Replace the keyless control unit.
9 CHECK IMPACT SENSOR. Check impact sensor. <Ref. to SL-53, CHECK IMPACT SENSOR, ADJUSTMENT, Impact Sensor.>	Is the sensibility set properly?	Press the UNLOCK/DISARM button of transmitter, and finish the diagnosis.	Adjust the sensibility. <Ref. to SL-53, IMPACT SENSITIVITY ADJUSTMENT, ADJUSTMENT, Impact Sensor.>

2. CHECK BATTERY DISCONNECT PROTECTION

- 1) Remove the key from the ignition switch.
- 2) Close all doors and the rear gate.
- 3) Open the front hood.
- 4) Press the LOCK/ARM button of the transmitter.
- 5) Disconnect the ground cable from the battery.
- 6) Reconnect the cable to the battery.
- 7) Check that the security indicator light blinks after reconnecting the battery cable.

If NG, replace the keyless entry control unit.

3. SECURITY SYSTEM ON/OFF SETTING

- 1) Close all doors and rear gate, sit down on the driver seat. Press the UNLOCK button of transmitter.
- 2) Turn the ignition switch to ON.
- 3) Press the centralized door lock switch to UNLOCK side and open the driver's door simultaneously, and maintain this state for 10 seconds.
- 4) The setting of security system (ON ↔ OFF) will be switched, and the horn sounds.

Setting	Notice
OFF → ON	Horn sounds once.
ON → OFF	Horn sounds twice.

NOTE:

Refer to the following for the ON/OFF setting of security system using Subaru Select Monitor. <Ref. to SL-49, PROCEDURE, Security Control Unit.>

Security System

SECURITY AND LOCKS

4. SYMPTOM CHART

Symptom		Repair order	Reference
1	Security system cannot be set.	1. Check the transmitter function.	<Ref. to SL-15, CHECK TRANSMITTER BATTERY AND FUNCTION, INSPECTION, Keyless Entry System.>
		2. Check the fuse.	<Ref. to SL-25, CHECK FUSE, INSPECTION, Security System.>
		3. Check the keyless entry control unit power supply and ground circuit.	<Ref. to SL-25, CHECK POWER SUPPLY AND GROUND CIRCUIT, INSPECTION, Security System.>
		4. Check the door switch.	<Ref. to SL-25, CHECK DOOR SWITCH, INSPECTION, Security System.>
		5. Replace the keyless entry control unit.	<Ref. to SL-49, Security Control Unit.>
2	Security indicator light or hazard light does not blink.	Security indicator light	<Ref. to SL-27, CHECK SECURITY INDICATOR LIGHT CIRCUIT, INSPECTION, Security System.>
		Hazard light	<Ref. to SL-28, CHECK HAZARD LIGHT OPERATION, INSPECTION, Security System.>
3	Security system does not alarm when one of the door, trunk lid or rear gate is opened.	Check the door switch.	<Ref. to SL-25, CHECK DOOR SWITCH, INSPECTION, Security System.>
4	Security alarm does not activate.	All functions	Check the door switch. <Ref. to SL-25, CHECK DOOR SWITCH, INSPECTION, Security System.>
		Security indicator light	Check the security indicator light circuit. <Ref. to SL-27, CHECK SECURITY INDICATOR LIGHT CIRCUIT, INSPECTION, Security System.>
		Security horn	Check the security horn. <Ref. to SL-27, CHECK SECURITY HORN, INSPECTION, Security System.>
		Hazard light	Check the hazard light operation. <Ref. to SL-28, CHECK HAZARD LIGHT OPERATION, INSPECTION, Security System.>
		Starter motor deactivation	Check the interrupt relay circuit. <Ref. to SL-28, CHECK INTERRUPT RELAY CIRCUIT, INSPECTION, Security System.>
5	Security system cannot be canceled.	Transmitter	Check the transmitter function. <Ref. to SL-15, CHECK TRANSMITTER BATTERY AND FUNCTION, INSPECTION, Keyless Entry System.>
		Ignition switch	Check the ignition switch circuit. <Ref. to SL-28, CHECK IGNITION SWITCH CIRCUIT, INSPECTION, Security System.>

5. CHECK FUSE

Step	Check	Yes	No
1 CHECK FUSE. Remove and visually check the fuse No. 2 (in main fuse box).	Is the fuse blown out?	Replace the fuse with a new one.	Check the power supply and ground circuit. <Ref. to SL-25, CHECK POWER SUPPLY AND GROUND CIRCUIT, INSPECTION, Security System.>

6. CHECK POWER SUPPLY AND GROUND CIRCUIT

Step	Check	Yes	No
1 CHECK POWER SUPPLY. 1) Disconnect the keyless entry control unit harness connector. 2) Measure the voltage between the harness connector terminal and chassis ground. <i>Connector & terminal</i> <i>(B176) No. 2 (+) — Chassis ground (-):</i>	Is the voltage more than 10 V?	Go to step 2.	Check the harness for open circuits and shorts between the keyless entry control unit and fuse.
2 CHECK GROUND CIRCUIT. Measure the resistance between the harness connector terminal and chassis ground. <i>Connector & terminal</i> <i>(B176) No. 14 — Chassis ground:</i>	Is the resistance less than 10 Ω?	The power supply and ground circuit are OK.	Repair the harness.

7. CHECK DOOR SWITCH

Step	Check	Yes	No
1 CHECK DOOR SWITCH CIRCUIT. Measure the voltage between the keyless entry control unit harness connector terminal and chassis ground when any door or rear gate is opened. <i>Connector & terminal</i> <i>Front and rear door:</i> <i>(B176) No. 6 (+) — Chassis ground (-):</i> <i>Trunk lid or rear gate:</i> <i>(B176) No. 7 (+) — Chassis ground (-):</i>	Is the voltage 0 V?	Go to step 2.	Go to step 3.
2 CHECK DOOR SWITCH CIRCUIT. Measure the voltage between the keyless entry control unit harness connector terminal and chassis ground when all doors and rear gate are closed. <i>Connector & terminal</i> <i>Front and rear door:</i> <i>(B176) No. 6 (+) — Chassis ground (-):</i> <i>Trunk lid or rear gate:</i> <i>(B176) No. 7 (+) — Chassis ground (-):</i>	Is the voltage more than 10 V?	The door switch is OK.	Go to step 3.

Security System

SECURITY AND LOCKS

Step	Check	Yes	No
3 CHECK DOOR SWITCH. 1) Disconnect the door switch harness connector. 2) Measure the resistance between the door switch terminals. <i>Terminals</i> <i>Door switch No. 1 — No. 3:</i> <i>Rear gate latch switch (Wagon model)</i> <i>No. 1 — No. 2:</i> <i>Trunk room light switch (Sedan model)</i> <i>No. 1 — No. 2:</i>	Is the resistance more than 1 M Ω when door switch is pushed?	Go to step 4.	Replace the door switch.
4 CHECK DOOR SWITCH. Measure the resistance between the door switch terminals. <i>Terminals</i> <i>Door switch No. 1 — No. 3:</i> <i>Rear gate latch switch (Wagon model)</i> <i>No. 1 — No. 2:</i> <i>Trunk room light switch (Sedan model)</i> <i>No. 1 — No. 2:</i>	Is the resistance less than 1 Ω when door switch is released?	Check the harness for open circuits and shorts between the keyless entry control unit and door switch.	Replace the door switch.

8. CHECK SECURITY INDICATOR LIGHT CIRCUIT

Step	Check	Yes	No
1 CHECK SECURITY INDICATOR LIGHT. 1) Disconnect the keyless entry control unit harness connector. 2) Ground the harness connector terminal with a suitable wire. <i>Connector & terminal</i> <i>(B176) No. 15 — Chassis ground:</i>	Does the security indicator light illuminate?	Replace the keyless entry control unit.	Go to step 2.
2 CHECK POWER SUPPLY FOR SECURITY INDICATOR LIGHT. 1) Disconnect the connector from the combination meter. 2) Measure the voltage between the combination meter harness connector terminal and chassis ground. <i>Connector & terminal</i> <i>(i11) No. 10 (+) — Chassis ground (-):</i>	Is the voltage more than 10 V?	Go to step 3.	Check the harness for open circuits and shorts between the combination meter and the fuse.
3 CHECK SECURITY INDICATOR LIGHT CIRCUIT. Measure the resistance between the combination meter harness connector terminal and keyless entry control unit harness connector terminal. <i>Connector & terminal</i> <i>(i10) No. 6 — (B176) No. 15:</i>	Is the resistance less than 10 Ω ?	Replace the combination meter printed circuit.	Check the harness for open circuits and shorts between the combination meter and keyless entry control unit.

9. CHECK SECURITY HORN

Step	Check	Yes	No
1 CHECK SECURITY HORN RELAY. Remove and check the security horn relay. <Ref. to SL-52, Security Horn Relay.>	Is the security horn OK?	Go to step 2.	Replace the security horn relay.
2 CHECK POWER SUPPLY FOR SECURITY HORN RELAY. Measure the voltage between the security horn relay harness connector terminal and chassis ground. <i>Connector & terminal</i> <i>(B243) No. 1 (+) — Chassis ground (-):</i>	Is the voltage more than 10 V?	Go to step 3.	Check the harness for open circuits and shorts between the security horn relay and horn relay.
3 CHECK POWER SUPPLY FOR SECURITY HORN RELAY. Measure the voltage between the security horn relay harness connector terminal and chassis ground. <i>Connector & terminal</i> <i>(B243) No. 2 (+) — Chassis ground (-):</i>	Is the voltage more than 10 V?	Go to step 4.	Check the harness for open circuits and shorts between the security horn relay and the fuse.
4 CHECK HARNESS BETWEEN SECURITY HORN RELAY AND KEYLESS ENTRY CONTROL UNIT. Measure the resistance between the security horn relay harness connector terminal and keyless entry control unit harness connector terminal. <i>Connector & terminal</i> <i>(B243) No. 4 — (B93) No. 16:</i>	Is the resistance less than 10 Ω ?	Go to step 5.	Check the harness for open circuits and shorts between the security horn relay and keyless entry control unit.
5 CHECK SECURITY HORN. Remove and check the security horn. <Ref. to SL-51, Security Horn.>	Is the security horn OK?	Replace the keyless entry control unit.	Replace the security horn.

Security System

SECURITY AND LOCKS

10.CHECK HAZARD LIGHT OPERATION

Step	Check	Yes	No
1 CHECK HAZARD LIGHT OPERATION. Check the hazard light blinks when hazard switch is turned ON.	Does the hazard light blink?	Go to step 2.	Check the hazard light circuit.
2 CHECK KEYLESS ENTRY CONTROL UNIT OUTPUT SIGNAL. 1) Remove the key from ignition switch. 2) Open the driver's window, and then close all doors and rear gate. 3) Lock all doors with the transmitter or door lock switch to arm the security system. 4) Unlock all doors with the door lock switch. 5) Measure the voltage between the keyless entry control unit harness connector terminal and chassis ground when any door is open. Connector & terminal (B176) No. 14 — Chassis ground:	Is the voltage 1 — 4 V?	Check the harness for open or short between keyless entry control unit and turn signal lights.	Replace the keyless entry control unit.

11.CHECK INTERRUPT RELAY CIRCUIT

Step	Check	Yes	No
1 CHECK INTERRUPT RELAY. Remove and check the interrupt relay. <Ref. to SL-54, Interrupt Relay.>	Is the interrupt relay OK?	Go to step 2.	Replace the interrupt relay.
2 CHECK POWER SUPPLY FOR INTERRUPT RELAY. Measure the voltage between the interrupt relay harness connector terminal and chassis ground. Connector & terminal (B422) No. 5 (+) — Chassis ground (-):	Is the voltage more than 10 V when ignition switch is turned to START?	Go to step 3.	Check the harness for open circuits and shorts between the interrupt relay and ignition switch.
3 CHECK HARNESS BETWEEN INTERRUPT RELAY AND KEYLESS ENTRY CONTROL UNIT. 1) Turn the ignition switch to OFF. 2) Disconnect the keyless entry control unit harness connector. 3) Measure the resistance between the interrupt relay harness connector terminal and keyless entry control unit harness connector. Connector & terminal (B422) No. 1 — (B176) No. 12:	Is the resistance less than 10 Ω ?	Replace the keyless entry control unit.	Check the harness for open circuits and shorts between the interrupt relay and keyless entry control unit.

12.CHECK IGNITION SWITCH CIRCUIT

Step	Check	Yes	No
1 CHECK IGNITION SWITCH SIGNAL. 1) Disconnect the keyless entry control unit harness connector. 2) Turn the ignition switch to ON. 3) Measure the voltage between the harness connector terminal and chassis ground. Connector & terminal (B176) No. 10 (+) — Chassis ground (-):	Is the voltage more than 10 V?	Ignition switch circuit is OK.	Check the harness for open circuits and shorts between the keyless entry control unit and ignition switch.

5. Front Inner Remote

A: REMOVAL

- 1) Remove the door trim. <Ref. to EI-41, REMOVAL, Front Door Trim.>
- 2) Remove the sealing cover. <Ref. to EB-17, REMOVAL, Front Sealing Cover.>
- 3) Remove a screw and two rod joints.
- 4) Remove the front inner remote.

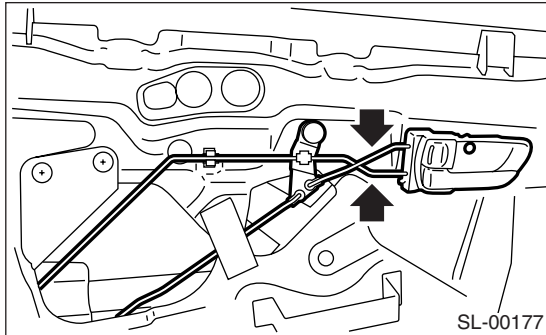

B: INSTALLATION

Install in the reverse order of removal.

NOTE:

Make sure the front inner remote works properly after installation.

C: INSPECTION

- 1) Make sure the rod is not deformed.
- 2) Make sure the lever and rod work smoothly.

6. Front Outer Handle

A: REMOVAL

- 1) Remove the door trim. <Ref. to EI-41, REMOVAL, Front Door Trim.>
- 2) Remove the sealing cover. <Ref. to EB-17, REMOVAL, Front Sealing Cover.>
- 3) Remove the bolt (A).
- 4) Move the front door glass downward. Remove the bolt and rod clamp.
- 5) Remove the front outer handle.

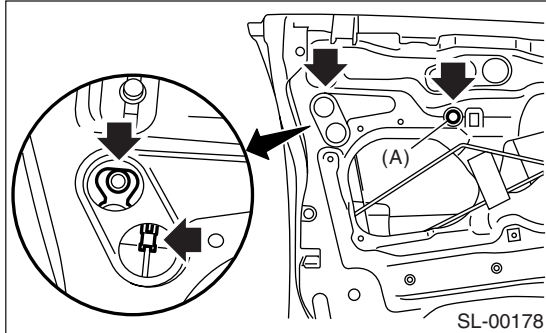

CAUTION:

Do not use excessive force to remove the handle from door panel. This will deform it.

B: INSTALLATION

Install in the reverse order of removal.

NOTE:

Make sure the front outer handle works properly after installation.

C: INSPECTION

- 1) Make sure the rod is not deformed.
- 2) Make sure the lever and rod work smoothly.

7. Front Door Latch and Door Lock Actuator Assembly

A: REMOVAL

- 1) Disconnect the ground cable from battery.
- 2) Remove the front door trim. <Ref. to EI-41, REMOVAL, Front Door Trim.>
- 3) Remove the sealing cover. <Ref. to EB-17, REMOVAL, Front Sealing Cover.>
- 4) Remove the front inner remote. <Ref. to SL-29, REMOVAL, Front Inner Remote.>
- 5) Remove three screws and a bolt.

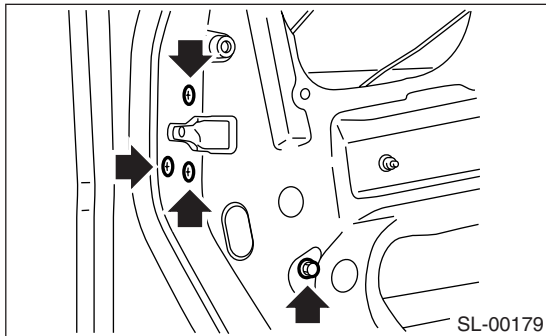

- 6) Remove the front door latch assembly, and then disconnect the connector.

B: INSTALLATION

Install in the reverse order of removal.

NOTE:

Make sure the lock works properly after installation.

C: INSPECTION

- 1) Make sure the rod is not deformed.
- 2) Make sure the lever and rod work smoothly.

8. Front Door Lock Actuator

A: REMOVAL

- 1) Remove the front door latch assembly. <Ref. to SL-31, REMOVAL, Front Door Latch and Door Lock Actuator Assembly.>
- 2) Remove the two screws to remove front door lock actuator.

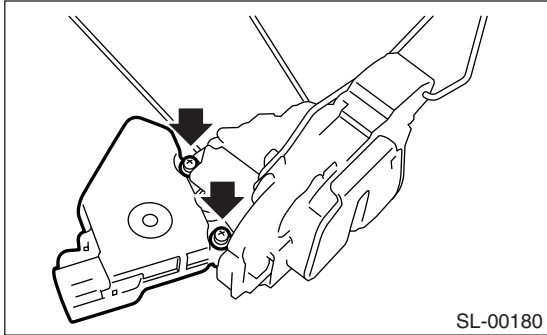

B: INSTALLATION

Install in the reverse order of removal.

NOTE:

Make sure the lock works properly after installation.

C: INSPECTION

- 1) Disconnect the front door lock actuator harness connector.
- 2) Connect the battery to front door lock actuator terminals.

If NG, replace the door lock actuator.

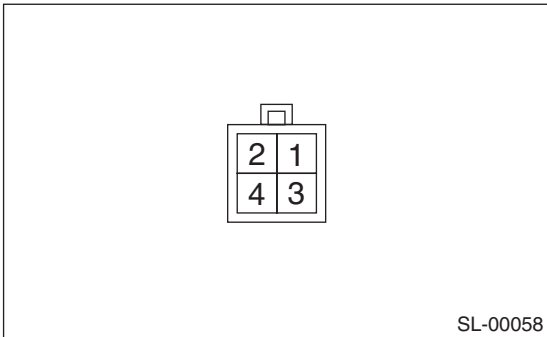

Terminal No.	Actuator operation
No. 3 (+) and No. 1 (-)	Unlocked → Locked
No. 1 (+) and No. 3 (-)	Locked → Unlocked

9. Rear Inner Remote

A: REMOVAL

- 1) Remove the rear door trim. <Ref. to EI-42, REMOVAL, Rear Door Trim.>
- 2) Remove the sealing cover. <Ref. to EB-20, REMOVAL, Rear Sealing Cover.>
- 3) Remove a screw and two rod joints.
- 4) Remove the rear inner remote.

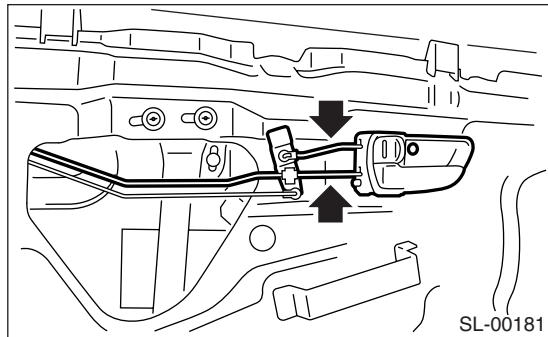

B: INSTALLATION

Install in the reverse order of removal.

NOTE:

Make sure the rear inner remote works properly after installation.

C: INSPECTION

- 1) Make sure the rod is not deformed.
- 2) Make sure the lever and rod work smoothly.
- 3) Make sure the child safety lock work properly.

10.Rear Outer Handle

A: REMOVAL

- 1) Remove the rear door trim. <Ref. to EI-42, REMOVAL, Rear Door Trim.>
- 2) Remove the sealing cover. <Ref. to EB-20, REMOVAL, Rear Sealing Cover.>
- 3) Remove the rear inner remote. <Ref. to SL-33, REMOVAL, Rear Inner Remote.>
- 4) Remove the rear door latch assembly. <Ref. to SL-35, REMOVAL, Rear Door Latch and Door Lock Actuator Assembly.>
- 5) Loosen two bolts and a nut to remove the rear outer handle.

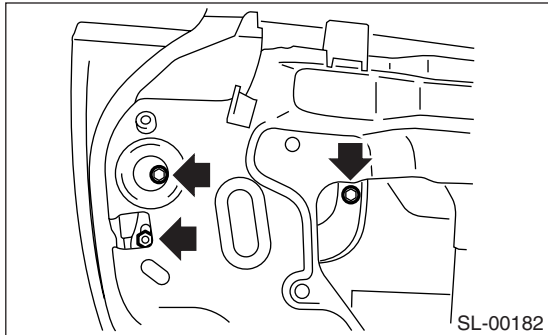

CAUTION:

Do not use excessive force to remove the handle from door panel. This will deform it.

B: INSTALLATION

Install in the reverse order of removal.

NOTE:

Make sure the rear outer handle works properly after installation.

C: INSPECTION

- 1) Make sure the rod is not deformed.
- 2) Make sure the outer handle and rod move smoothly.

11. Rear Door Latch and Door Lock Actuator Assembly

A: REMOVAL

- 1) Disconnect the ground cable from battery.
- 2) Remove the rear door trim. <Ref. to EI-42, REMOVAL, Rear Door Trim.>
- 3) Remove the sealing cover. <Ref. to EB-20, REMOVAL, Rear Sealing Cover.>
- 4) Remove the rear inner remote. <Ref. to SL-33, REMOVAL, Rear Inner Remote.>
- 5) Remove three screws and a bolt.

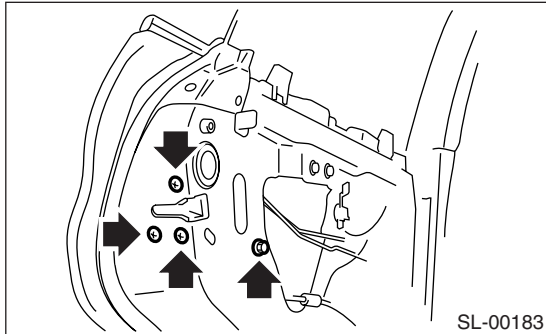

- 6) Disconnect the connector, and then remove the rear door latch assembly.

B: INSTALLATION

Install in the reverse order of removal.

NOTE:

Make sure the lock works properly after installation.

C: INSPECTION

- 1) Make sure the rod is not deformed.
- 2) Make sure the outer handle, rear remote handle and rod move smoothly.

12.Rear Door Lock Actuator

A: REMOVAL

- 1) Remove the rear door latch assembly. <Ref. to SL-35, REMOVAL, Rear Door Latch and Door Lock Actuator Assembly.>
- 2) Loosen two screws to remove rear door lock actuator.

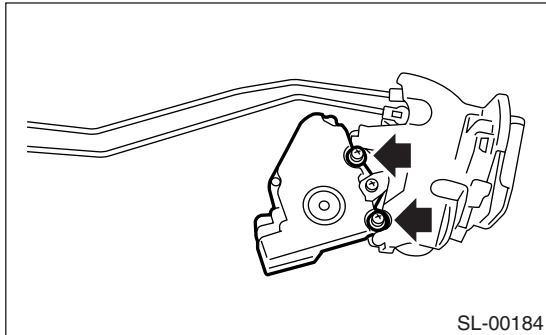

B: INSTALLATION

Install in the reverse order of removal.

NOTE:

Make sure the lock works properly after installation.

C: INSPECTION

- 1) Disconnect the rear door lock actuator harness connector.
- 2) Connect the battery to rear door lock actuator terminals.

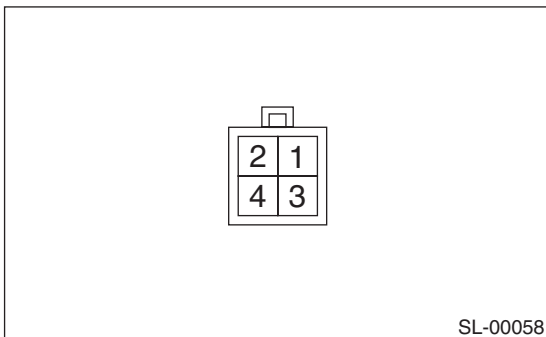

Terminal No.	Actuator operation
No. 3 (+) and No. 1 (-)	Unlocked → Locked
No. 1 (+) and No. 3 (-)	Locked → Unlocked

If NG, replace the door lock actuator.

13.Rear Gate Outer Handle

A: REMOVAL

- 1) Remove the rear gate trim. <Ref. to EI-57, REMOVAL, Rear Gate Trim.>
- 2) Remove the rear gate latch assembly. <Ref. to SL-38, REMOVAL, Rear Gate Latch Assembly.>
- 3) Remove the two nuts to remove the rear gate outer handle.

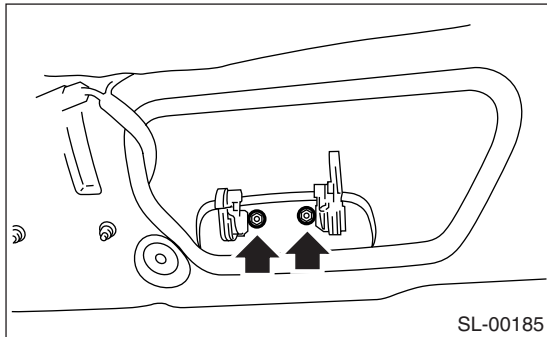

B: INSTALLATION

Install in the reverse order of removal.

NOTE:

Make sure the rear gate outer handle works properly after installation.

C: INSPECTION

- 1) Inspect the rod for deformation.
- 2) Make sure the outer handle and cable move smoothly.

14. Rear Gate Latch Assembly

A: REMOVAL

- 1) Disconnect the ground cable from battery.
- 2) Remove the rear gate trim. <Ref. to EI-57, REMOVAL, Rear Gate Trim.>
- 3) Remove three bolts.

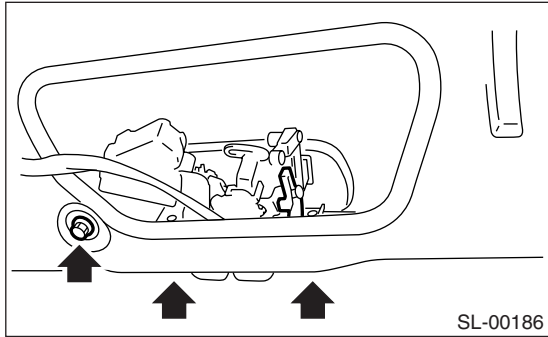

- 4) Disconnect the connectors, and then remove the rear gate latch assembly.

B: INSTALLATION

Install in the reverse order of removal.

NOTE:

Make sure the lock works properly after installation.

C: INSPECTION

- 1) Make sure the rod is not deformed.
- 2) Make sure the outer handle and cable move smoothly.

15. Rear Gate Latch Lock Actuator

A: REMOVAL

- 1) Remove the rear gate latch assembly. <Ref. to SL-38, REMOVAL, Rear Gate Latch Assembly.>
- 2) Loosen two screws to remove the rear gate lock actuator.

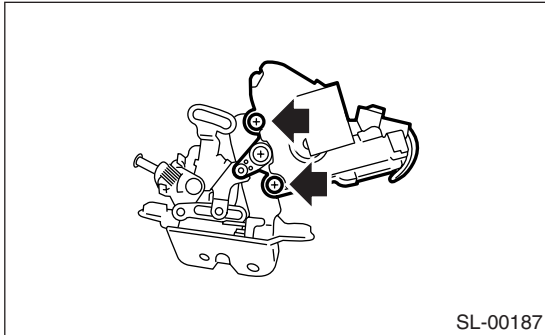

B: INSTALLATION

Install in the reverse order of removal.

NOTE:

Make sure the lock works properly after installation.

C: INSPECTION

- 1) Disconnect the rear gate latch lock actuator harness connector.
- 2) Connect the battery to rear gate latch lock actuator terminals.

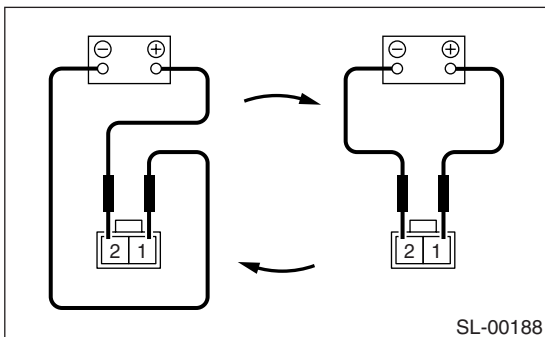

Terminal No.	Actuator operation
No. 1 (+) and No. 2 (-)	Unlocked → Locked
No. 2 (+) and No. 1 (-)	Locked → Unlocked

If NG, replace the rear gate latch lock actuator.

16. Trunk Lid Lock Assembly

A: REMOVAL

- 1) Remove the trunk lid key cylinder rod clamp.
- 2) Loosen two bolts to remove the trunk lid lock assembly.

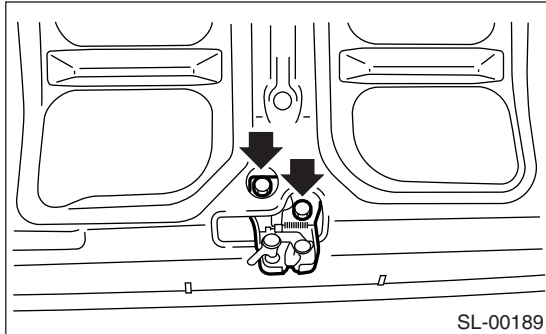

B: INSTALLATION

Install in the reverse order of removal.

NOTE:

- Apply grease to parts that rub.
- Make sure the lock works properly after installation.

C: INSPECTION

- 1) Check the striker for bending or abnormal wear.
- 2) Check the safety lever for improper movement.
- 3) Check other levers and the spring for rust formation and unsmooth movement.

17. Trunk Lid Release Handle

A: REMOVAL

1) Remove the five clips.

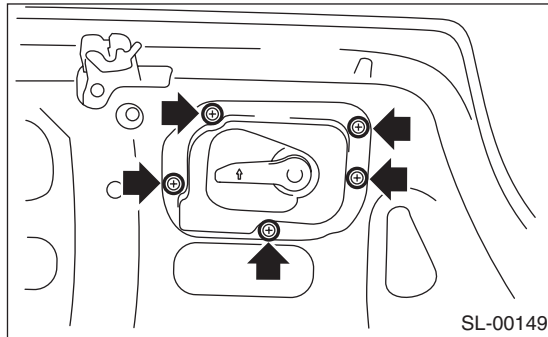

2) Remove the cable from trunk lid release handle.

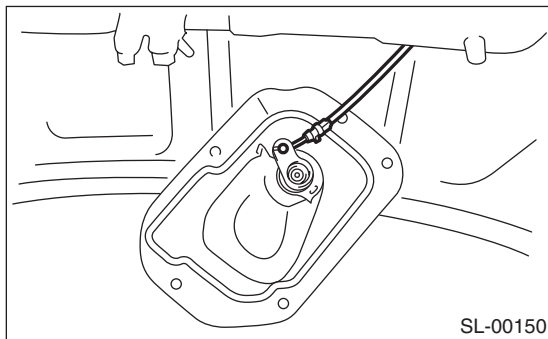

B: INSTALLATION

Install in the reverse order of removal.

C: INSPECTION

- 1) Make sure the cable is not deformed.
- 2) Make sure the lever works smoothly.

18. Front Hood Lock Assembly

A: REMOVAL

- 1) Open the front hood.
- 2) Remove the bolts. Remove the hood lock assembly.

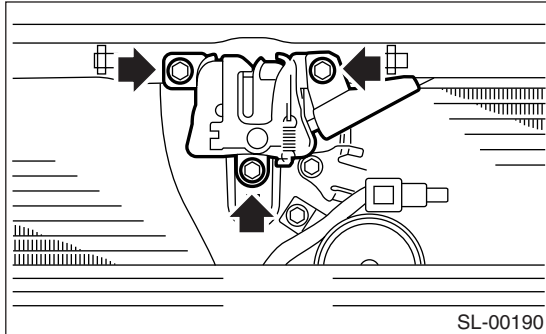

- 3) Remove the release cable from front hood lock assembly.

B: INSTALLATION

Install in the reverse order of removal.

NOTE:

- Apply grease to parts that rub.
- Make sure the release cable works properly after installation.

C: ADJUSTMENT

Loosen the bolt. Adjust the front hood lock assembly while moving it up and down.

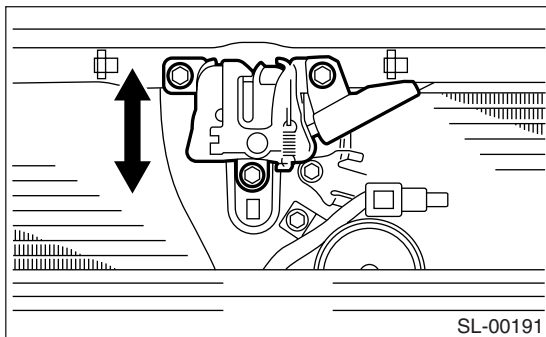

D: INSPECTION

- 1) Check the striker for bending or abnormal wear.
- 2) Check the safety lever for improper movement.
- 3) Check other levers and the spring for rust formation and unsmooth movement.

19. Remote Openers

A: REMOVAL

1. HOOD OPENER

- 1) Remove the release cable from front hood lock assembly.
- 2) Remove the bolt. Remove the lever assembly.

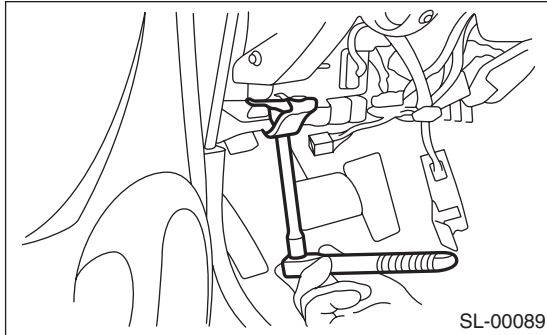

2. TRUNK LID OPENER

- 1) Remove the rear seat. <Ref. to SE-13, REMOVAL, Rear Seat.>
- 2) Remove the center pillar lower trim, and remove the side sill cover on passenger side. Remove the rear pillar lower trim. Pull back the floor mat. Remove the clip holding the cable.
- 3) Remove the bolt. Remove the pull handle assembly.

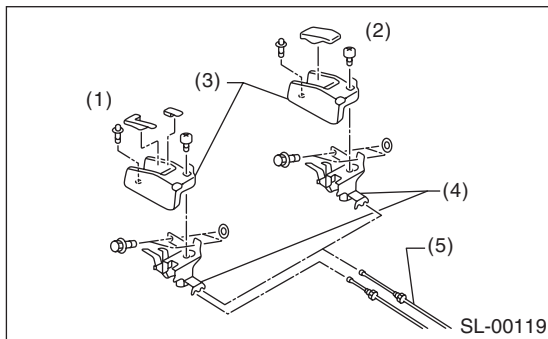

- (1) Sedan
- (2) Wagon
- (3) Cover
- (4) Pull handle ASSY
- (5) Cable

- 4) Remove the cable from pull handle assembly.
- 5) Remove the striker from trunk lid.

- 6) Remove the cable from striker.

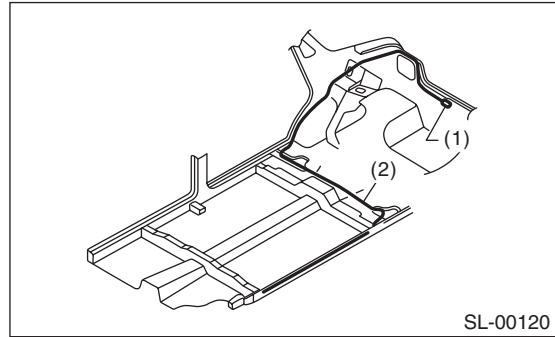

- (1) Striker
- (2) Cable

3. FUEL FLAP OPENER

- 1) Remove the rear seat. <Ref. to SE-13, REMOVAL, Rear Seat.>
- 2) Remove the center pillar lower trim, and remove the side sill cover on passenger side. Remove the rear pillar lower trim. Pull back the floor mat. Remove the clip holding the cable.
- 3) Remove the bolt. Remove the pull handle assembly.

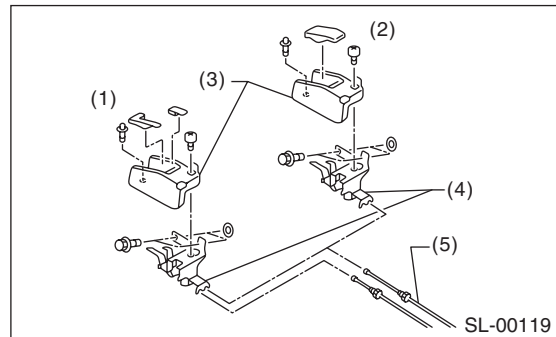

- (1) Sedan
- (2) Wagon
- (3) Cover
- (4) Pull handle ASSY
- (5) Cable

- 4) Remove the cable from pull handle assembly.
- 5) Remove the right rear quarter trim. <Ref. to EI-52, REMOVAL, Rear Quarter Trim.>

Remote Openers

SECURITY AND LOCKS

6) Rotate the fuel lock inside the quarter panel to left and remove.

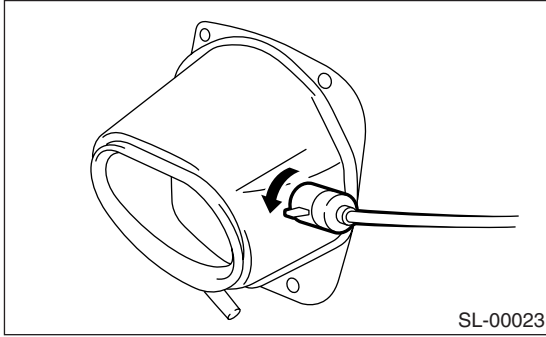

B: INSTALLATION

1. HOOD OPENER

Install in the reverse order of removal.

2. TRUNK LID OPENER

Install in the reverse order of removal.

3. FUEL FLAP OPENER

Install in the reverse order of removal.

C: INSPECTION

Make sure the fuel filler flap lid opens and closes smoothly.

20. Ignition Key Lock

A: REPLACEMENT

- 1) Remove the ground cable from battery.
- 2) Remove the steering column. <Ref. to PS-23, REMOVAL, Tilt Steering Column.>
- 3) Secure the steering column in a vise. Remove the bolt with a drill.

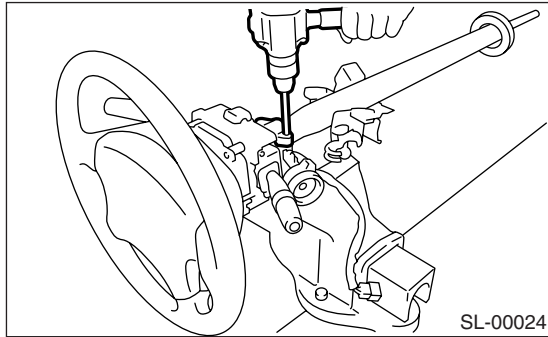

- 4) Remove the ignition key lock.
- 5) Use a new torn bolt. Tighten the torn bolt to end of thread.

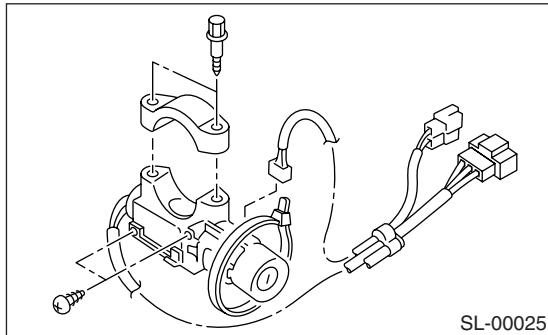

B: INSPECTION

- 1) Remove the instrument panel lower cover.
- 2) Remove the lower column cover.
- 3) Unfasten the hold-down clip which secures harness and disconnect the connector of ignition switch from body harness.
- 4) Turn the ignition key plate to each position and check the continuity between terminals of ignition connector.

Switch position	Terminal No.	Standard
LOCK	—	—
ACC	No. 1 and No. 2	Less than 1 Ω
ON	No. 1 and No. 2 No. 1 and No. 4 No. 2 and No. 4	Less than 1 Ω
ST	No. 1 and No. 3 No. 1 and No. 4 No. 3 and No. 4	Less than 1 Ω

If NG, replace the ignition switch.

21. Key Lock Cylinders

A: REPLACEMENT

1. FRONT DOOR

- 1) Remove the door trim. <Ref. to EI-41, REMOVAL, Front Door Trim.>
- 2) Pull back the sealing cover.
- 3) Move the front door glass downward.
- 4) Remove the rod clamp. Remove the bolt. Replace the key cylinder.

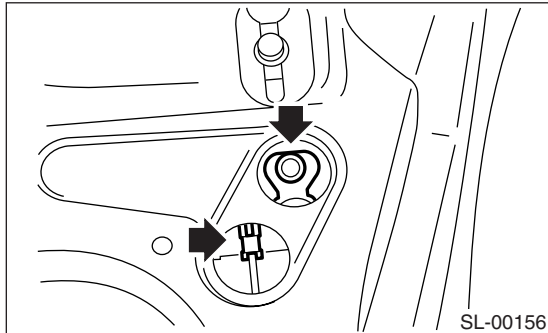

2. TRUNK LID

- 1) Remove the trunk lid release handle. <Ref. to SL-41, Trunk Lid Release Handle.>
- 2) Remove the rod clamp. Remove the lock plate. Replace the key cylinder.

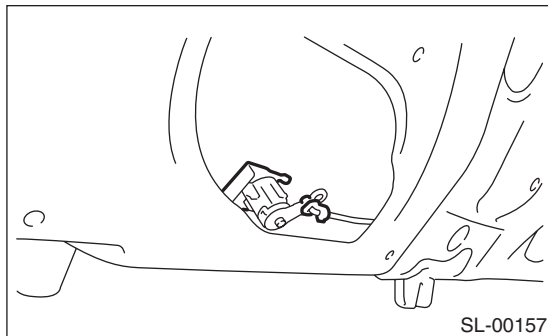

22. Immobilizer Control Unit

A: REMOVAL

NOTE:

- Prepare the security ID plate.
 - Prepare all registered immobilizer keys for the model with immobilizer.
 - Make a registration of immobilizer when replacing the immobilizer control unit. New immobilizer key is required for registration. For detailed operation procedure, refer to "IMMOBILIZER REGISTRATION MANUAL".
 - If the keys are added without replacing the immobilizer control unit, maximum 4 keys can be registered including new keys.
- 1) Disconnect the ground cable from battery.
 - 2) Remove the instrument panel lower cover. <Ref. to EI-47, REMOVAL, Instrument Panel Assembly.>
 - 3) Disconnect the connector from immobilizer control unit.
 - 4) Remove the immobilizer control unit.

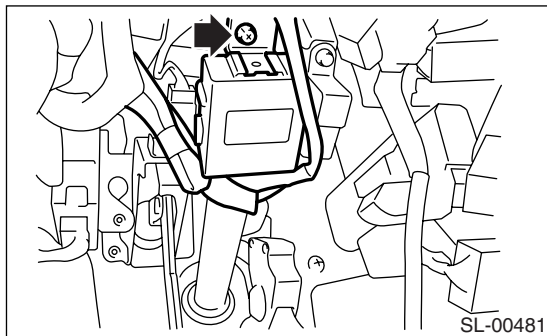

B: INSTALLATION

Install in the reverse order of removal.

23. Immobilizer Antenna

A: REMOVAL

- 1) Disconnect the ground cable from battery.
- 2) Remove the instrument panel lower cover. <Ref. to EI-47, REMOVAL, Instrument Panel Assembly.>
- 3) Remove the screws, separate upper column cover and lower column cover.

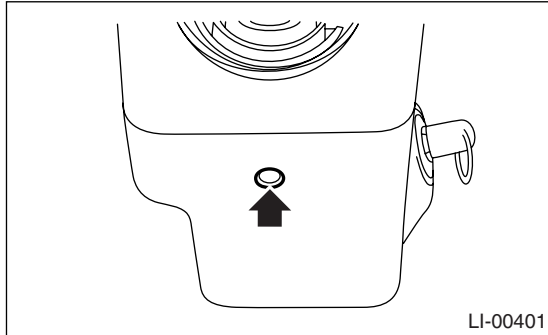

- 4) Disconnect the immobilizer antenna connector (A) from body harness.
- 5) Remove the screw, and detach the immobilizer antenna (B).

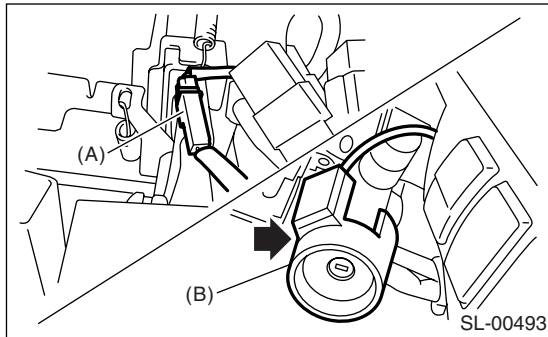

B: INSTALLATION

Install in the reverse order of removal.

24. Security Control Unit

A: NOTE

The control of security system is performed by the keyless entry control unit.

B: REMOVAL

<Ref. to SL-55, REMOVAL, Keyless Entry Control Unit.>

C: INSTALLATION

<Ref. to SL-55, INSTALLATION, Keyless Entry Control Unit.>

D: PROCEDURE

1. FUNCTION SETTING (ECM CUSTOMIZING)

- 1) Connect the Subaru Select Monitor to data link connector.
- 2) Turn the ignition switch to ON.
- 3) On the «Main Menu» display screen, select the {Each System Check} and press the [YES] key.
- 4) On the «System Selection Menu» display screen, select the {Keyless Unit Mode} and press the [YES] key.
- 5) On the «Integ. Unit mode failuer diag» display screen, select the {ECM customizing} and press the [YES] key.
- 6) Change the setting with UP/DOWN key and press the [YES] key.
 - List of function setting item (ECM customizing)

No.	Data	Initial setting value	Customize setting	Remarks
1	Security Alarm Setup	OFF	ON	Security alarm (hazard, horn) is active.
			OFF	Security alarm is inactive.
2	Alarm monitor delay setup	ON		After doors are locked by keyless entry system operated, Alarm monitor starts in the following delay time.
			ON	Delay time is 30 seconds.
			OFF	Delay time is 0 seconds.
3	Impact Sensor Setup	OFF	ON	Workable when Impact Sensor Setup is set to "ON". Impact sensor is in active condition.
			OFF	Impact sensor is in inactive condition. (Set Impact Sensor Setup of model without impact sensor to "OFF".)
4	Impact sensor	OFF	ON	Vehicle is controlled with impact sensor equipped mode. (Set it to "OFF" for the model without impact sensor. If it is set to "ON", hazard, horn or siren operates with keyless entry system operated (alarm monitor starting).)
			OFF	Vehicle is controlled in impact sensor no-equipped mode.
5	Passive Alarm	OFF	ON	There is no function that it is automatically set to ARM without user's intentional locking (ARM).
			OFF	Workable when passive arming is set to "ON".

7) After setting, make sure that vehicle equipment is same as the setting changed in the {Current Data Display & Save}.

CAUTION:

- It is possible to control the original functions of vehicle when settings above are corresponded to vehicle equipment.
- Do not change the settings except for setting above during operation of equipment setting.
- Resetting is needed if installing a new keyless unit.
- In passive mode, the system will automatically activate the alarm but WILL NOT automatically lock the doors. Failure to lock the doors manually will result in a higher security risk.

NOTE:

For details concerning operation procedure, refer to the SUBARU SELECT MONITOR OPERATION MANUAL.

8) Turn the ignition switch to OFF, and then remove the Subaru Select Monitor.

Security Control Unit

SECURITY AND LOCKS

2. ALARM HISTORY REPORT MODE

- 1) Turn the ignition switch to ON.
- 2) Security indicator light blinks.

The number of times security indicator light blinks	Vehicle state
Once	WARNNG is activated by impact sensor (OP). It may be caused by light impact on outside of vehicle or other person's vandalism.
2 times	ALARM is activated by impact sensor (OP). It may be caused by strong impact on outside of vehicle or other person's vandalism.
3 times	The ignition switch has been turned to ON.
4 times	The rear gate has been opened.
5 times	One of the doors has been opened.

NOTE:

- If the ALARM/WARNING occurs in the ARM mode, the indicator light blinks when the ignition switch is turned to OFF → ON at the next DISARM mode.
- If ALARM/WARNING does not occur, the light does not blink.
- More than one alarm or warning occurs, the most numbers of blinking times have priority to blink.
- Anytime the ignition switch is turned to ON in the DISARM mode, it blinks. The memory will be updated at the next ARM mode.

25.Security Horn

A: REMOVAL

- 1) Disconnect the ground cable from battery.
- 2) Remove the nuts and then detach the security horn while disconnecting the connector.

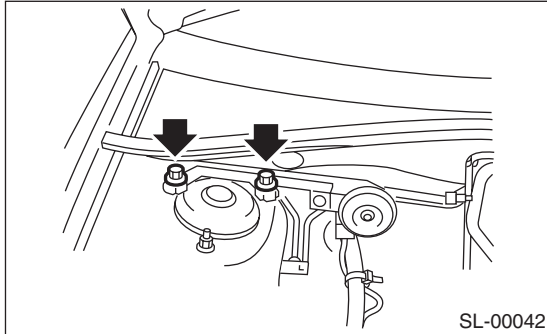

B: INSTALLATION

Install in the reverse order of removal.

C: INSPECTION

Connect the battery to the security horn terminal and case ground and make sure the horn sounds properly.

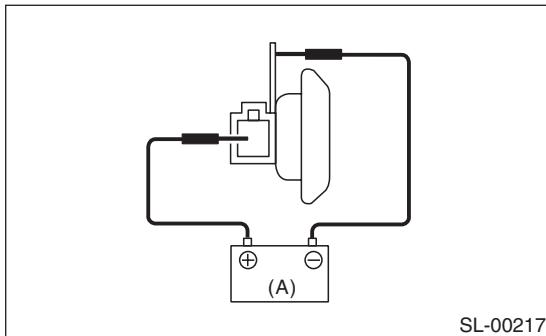

(A) Battery

If NG, replace the security horn.

26. Security Horn Relay

A: REMOVAL

- 1) Disconnect the ground cable from battery.
- 2) Remove the mounting bolt and detach the security horn relay.

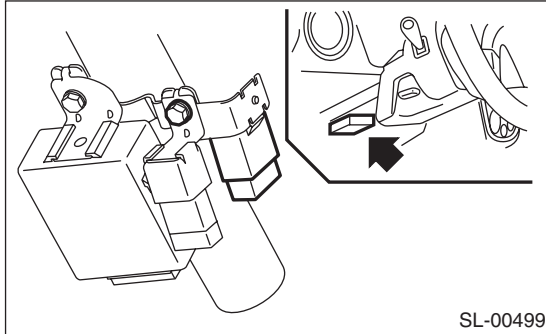

B: INSTALLATION

Install in the reverse order of removal.

C: INSPECTION

Measure the security horn relay resistance between terminals (indicated in the table below) when connecting terminal No. 4 to battery positive terminal and terminal No. 1 to battery ground terminal.

Current	Terminal No.	Standard value
Flow	2 and 3	Less than 1 Ω
No flow		More than 1 M Ω

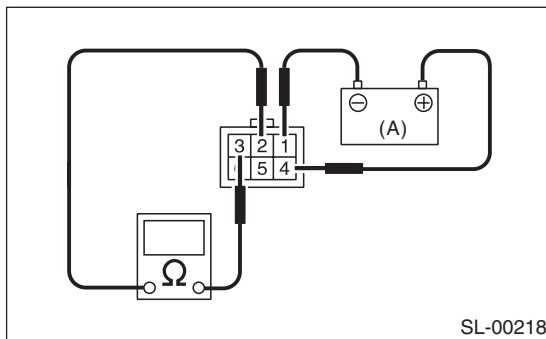

(A) Battery

If NG, replace the security horn relay.

27. Impact Sensor

A: REMOVAL

- 1) Remove the key from ignition switch.
- 2) Close all the doors, trunk lid and rear gate.
- 3) Press the UNLOCK button of transmitter.
- 4) Change the setting of impact sensor using Subaru Select Monitor.
- 5) Disconnect the ground cable from battery.
- 6) Remove the impact sensor.

B: INSTALLATION

- 1) Remove the key from ignition switch.
- 2) Close all the doors, trunk lid and rear gate.
- 3) Press the UNLOCK button of transmitter.
- 4) Disconnect the ground cable from battery.
- 5) Install the impact sensor.
- 6) Connect the battery ground cable to battery.
- 7) Change the setting of impact sensor using Subaru Select Monitor.

C: OPERATION

1. IMPACT SENSOR SETTING USING SUBARU SELECT MONITOR

- 1) Connect the Subaru Select Monitor to data link connector.
- 2) Turn the ignition switch to ON.
- 3) Select {Keyless Unit} from the main menu.
- 4) Select {ECU customizing}.
- 5) Make a impact monitor setting.
 - When installing: ON
 - When removing: OFF
- 6) Make a impact monitor ON/OFF setting.
 - When installing: ON
 - When removing: OFF
- 7) Turn the ignition switch to OFF, and then remove the Subaru Select Monitor.

D: ADJUSTMENT

1. CHECK IMPACT SENSOR

- 1) Remove the key from ignition switch.
- 2) Close all windows.
- 3) Close all the doors, trunk lid and rear gate. Leave open the front hood.
- 4) Press the LOCK button of the transmitter from outside vehicle.
- 5) Check that the security indicator light blinks twice within 0.5 seconds in 2 seconds cycle after 30 seconds.
- 6) Hit the windshield with your palm continuously and check the security alarm operates. Lift up the front hood approx. 12 cm (4.7 in), and then drop it off to check the operation of security alarm.
- 7) If NG, adjust the impact sensitivity.

2. IMPACT SENSITIVITY ADJUSTMENT

- 1) Connect the Subaru Select Monitor to data link connector.
- 2) Turn the ignition switch to ON.
- 3) Select {Impact Sensor} from the main menu.
- 4) Make a {ECU customizing}.
 - Sensitivity can be adjusted in 11 levels (0 to 10).
 - Initial setting is 5.
 - Smaller number means more sensitive.
 - Larger number means less sensitive.
- 5) Turn the ignition switch to OFF, and then remove the Subaru Select Monitor.

NOTE:

- Set the sensor so as not to let the alarm on normal vibration (reclining to the door, hit the ball and etc.).
- Set the sensor to operate the alarm with hitting the door or window glass, etc. continuously like a mayhem by robbery.
- Ask the customer about parking situation for setting, because the alarm operate when the vibration not only the burglar but also the construction etc.

28. Interrupt Relay

A: REMOVAL

- 1) Disconnect the ground cable from battery.
- 2) Remove the audio instrument. <Ref. to ET-6, REMOVAL, Audio.>
- 3) Remove the interrupt relay.

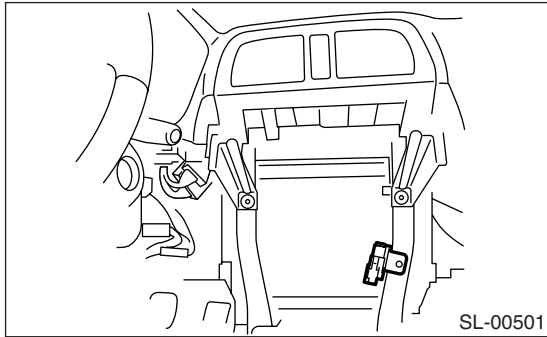

B: INSTALLATION

Install in the reverse order of removal.

C: INSPECTION

Measure the interrupt relay resistance between terminals (indicated in the table below) when connecting terminal No. 3 to battery positive terminal and terminal No. 1 to battery ground terminal.

Current	Terminal No.	Standard value
Flow	2 and 5	More than 1 MΩ
No flow		Less than 1 Ω
Flow	4 and 5	Less than 1 Ω
No flow		More than 1 MΩ

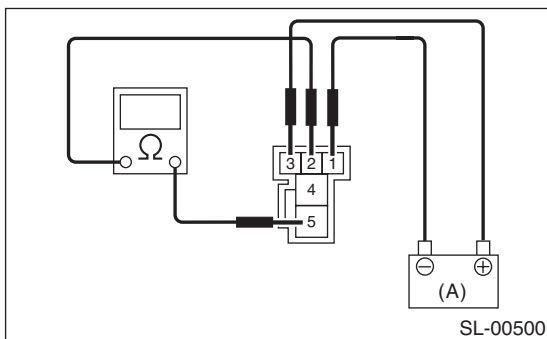

(A) Battery

If NG, replace the interrupt relay.

CAUTION:

Do not connect the terminals to battery positive terminal and ground terminal incorrectly. If this happens, replace the interrupt relay.

29. Keyless Entry Control Unit

A: REMOVAL

- 1) Disconnect the ground cable from battery.
- 2) Remove the instrument panel lower cover. <Ref. to EI-47, REMOVAL, Instrument Panel Assembly.>
- 3) Remove the nut, and then remove the keyless entry control unit while disconnecting connector.

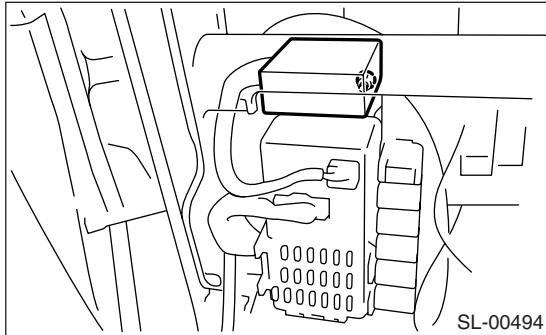

- 4) Disconnect the keyless entry control unit and other electrical control module.

B: INSTALLATION

Install in the reverse order of removal.

30. Body Integrated Module

A: REMOVAL

- 1) Disconnect the ground cable from battery.
- 2) Remove the instrument panel lower cover. <Ref. to EI-47, REMOVAL, Instrument Panel Assembly.>
- 3) Remove the nut, then remove the body integrated module while disconnecting the connector.

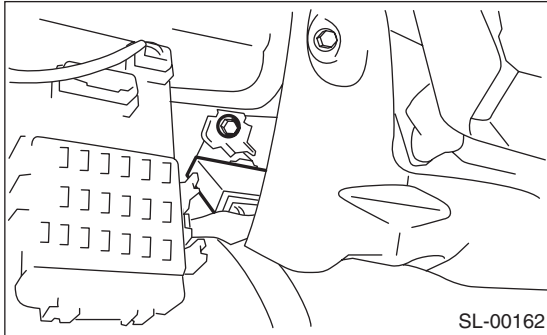

B: INSTALLATION

Install in the reverse order of removal.

31. Transmitter

A: REMOVAL

1. TRANSMITTER BATTERY

Remove the battery (1) from transmitter.

NOTE:

To prevent static electricity damage to transmitter printed circuit board, touch the steel area of building with hand to discharge the static electricity carried on body or clothes before disassembling transmitter.

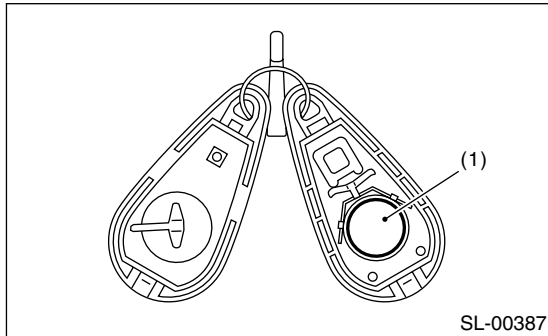

B: INSTALLATION

1. TRANSMITTER BATTERY

Install in the reverse order of removal.

C: INSPECTION

1. TRANSMITTER BATTERY

Measure the voltage between the transmitter battery (+) terminal and (-) terminal.

NOTE:

Battery discharge occurs during measurement. Complete the measurement within 5 seconds.

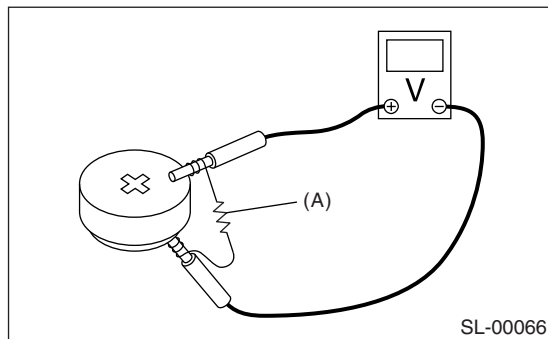

(A) Resistance 47 Ω

Tester connection		Standard
(+)	(-)	
Battery Positive terminal	Battery Ground terminal	2.5 — 3.0 V

If NG, replace the battery. (Use CR2025 or equivalent.)

D: REPLACEMENT

1. REGISTRATION OF TRANSMITTER WITH SUBARU SELECT MONITOR

NOTE:

- A maximum of four transmitters can be registered for each individual vehicle.
- When replacing or adding the transmitter, new registration of transmitter is necessary.

- 1) Connect the Subaru Select Monitor to the vehicle.
- 2) Turn the ignition switch to ON.
- 3) From the «Main menu» on the Subaru Select Monitor, select the {2. Check individual system} → {Keyless unit mode} → {1. Keyless ID registration}, and press the [YES] key.
- 4) Input the 8-digit ID number from the left attached to the plastic bag of transmitter or circuit board inside transmitter.

NOTE:

Press the [▲] key on the Subaru Select Monitor to increase the number, and the [▼] key to decrease. Press the [<] key to move to the digit in the left, and [>] to the right.

- 5) The ID number you have entered will be shown. Make sure that the ID number shown is the same as that of plastic bag.
- 6) Press the [YES] key if the ID number is correct. Press the [NO] key if incorrect, to return to the step 3) and try again.
- 7) «ID registration in process...» will be displayed and registration started.
- 8) «ID registration done» will be shown when the process is done.
- 9) To end, select the «END:NO», and press the [NO] key to return to {1. Keyless ID registration}. If there are additional transmitters to be registered, select the «Next registration:YES», and press the [YES] key to return to the step 3).

NOTE:

- If the registration fails, «ID registration failed. Try again.» will be shown. Press the [YES] key to return to the {1. Keyless ID registration} and retry from the step 2).
- «END: NO» is shown on the Subaru Select Monitor when four transmitters have been registered. Press the [NO] key to return to {1. Keyless ID registration}.

