

GLASS/WINDOWS/MIRRORS

General Description

GLASS/WINDOWS/MIRRORS

1. General Description

A: COMPONENT

1. FIXED GLASS (SEDAN MODEL)

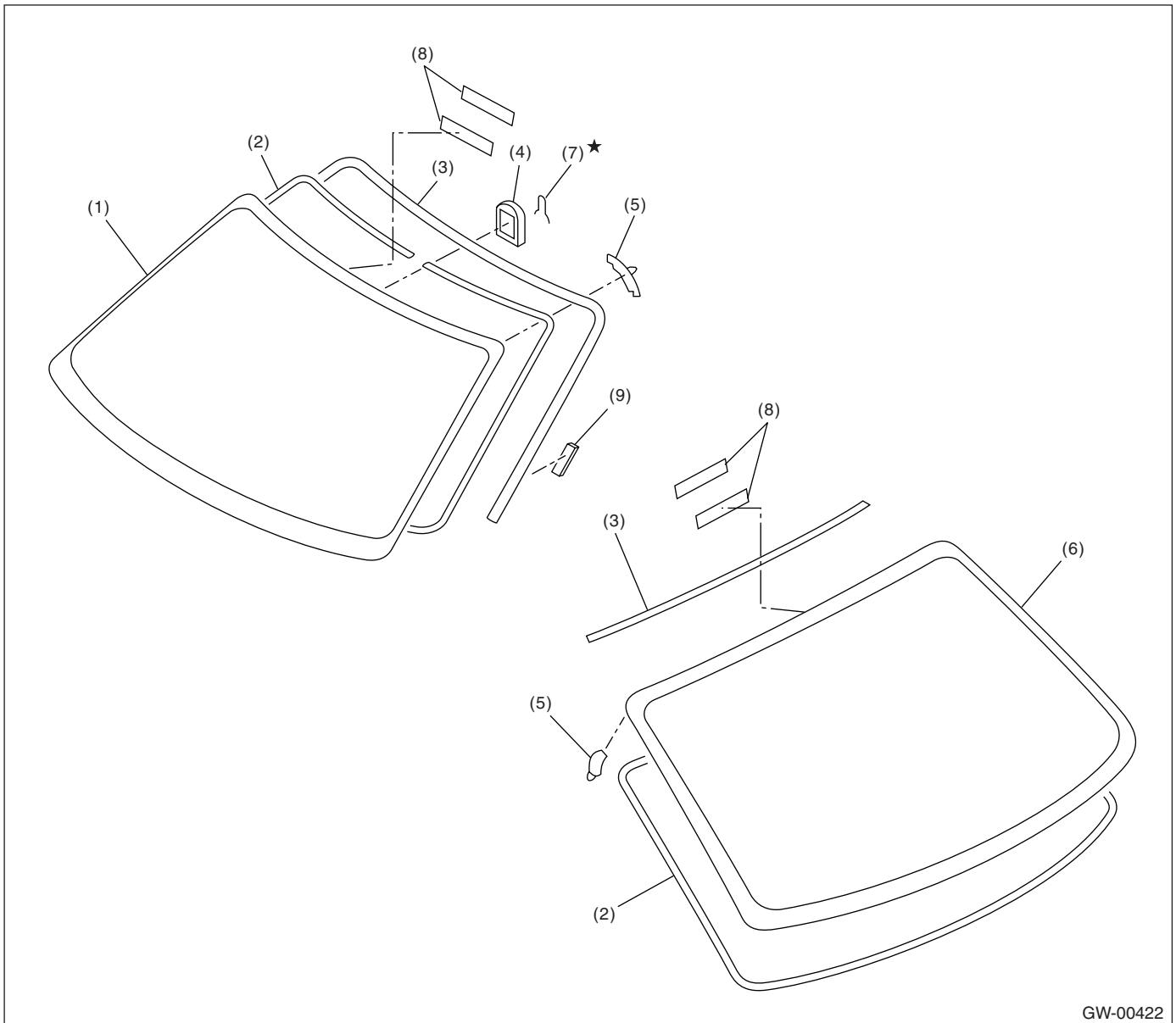

- (1) Windshield glass
- (2) Dam rubber
- (3) Molding

- (4) Rearview mirror mount
- (5) Locating pin
- (6) Rear window glass

- (7) Spring
- (8) Fastener
- (9) Seal

2. FIXED GLASS (WAGON MODEL)

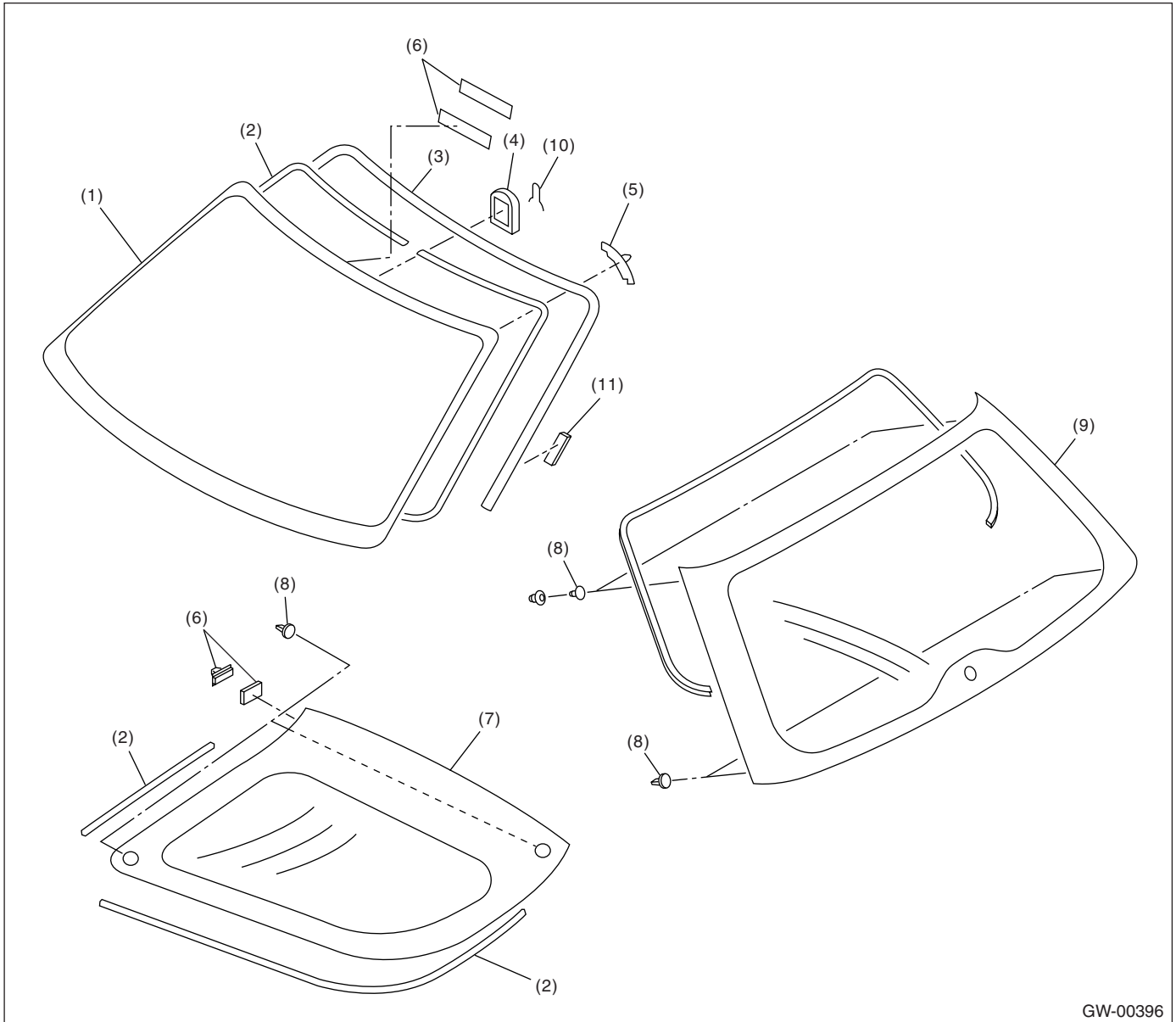

GW-00396

- | | | |
|---------------------------|------------------------|---------------------|
| (1) Windshield glass | (5) Locating pin | (9) Rear gate glass |
| (2) Dam rubber | (6) Fastener | (10) Spring |
| (3) Molding | (7) Rear quarter glass | (11) Seal |
| (4) Rearview mirror mount | (8) Locating pin | |

General Description

GLASS/WINDOWS/MIRRORS

3. FRONT DOOR GLASS

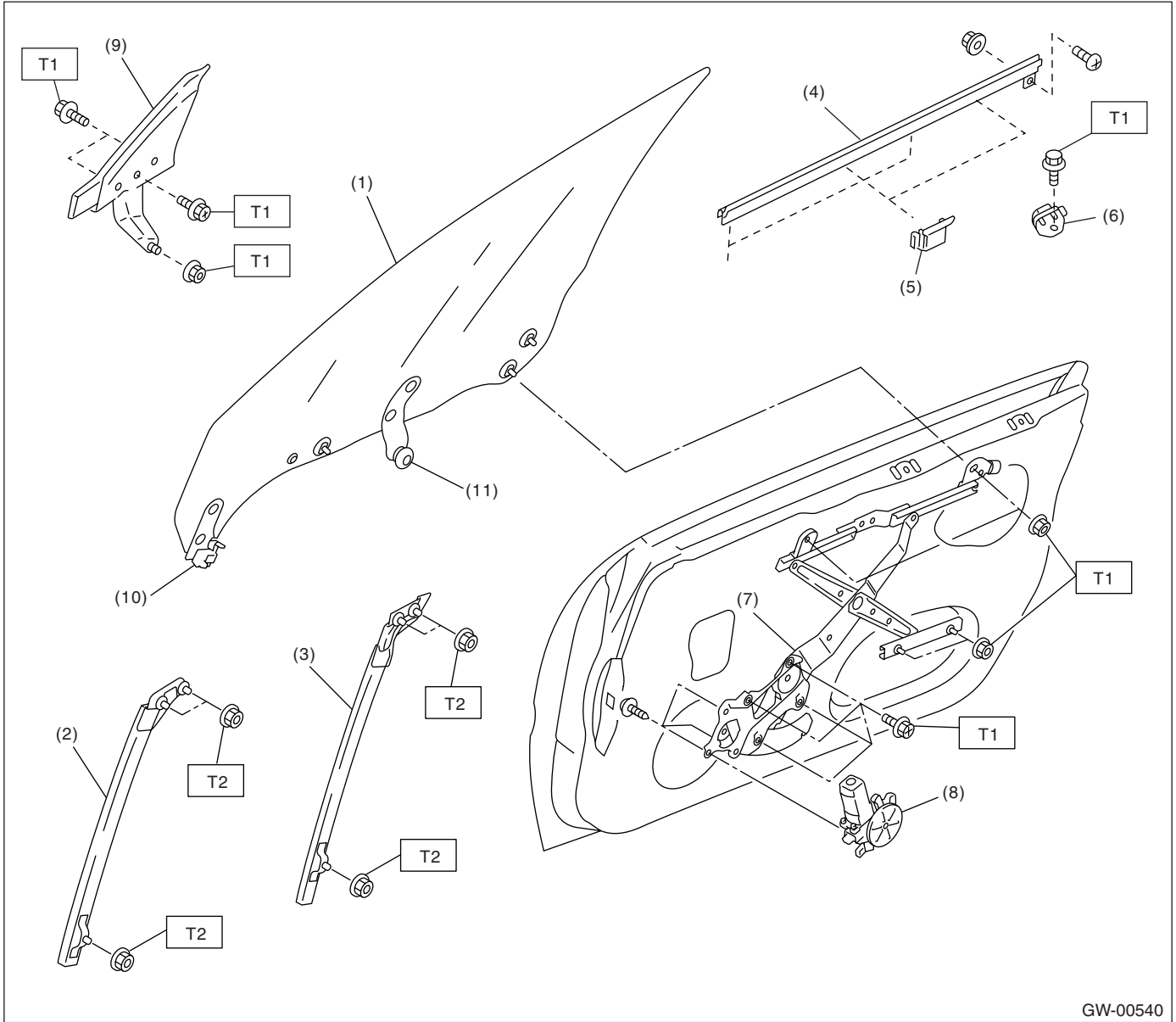

- | | |
|------------------------|------------------------|
| (1) Glass | (6) Stabilizer (Inner) |
| (2) Door sash (Front) | (7) Regulator ASSY |
| (3) Door sash (Rear) | (8) Motor ASSY |
| (4) Weather strip | (9) Mirror gusset |
| (5) Stabilizer (Outer) | (10) Slider |

- (11) Roller

Tightening torque: N·m (kgf·m, ft·lb)

T1: 7.4 (0.75, 5.5)

T2: 13.7 (1.4, 10.1)

4. REAR DOOR GLASS

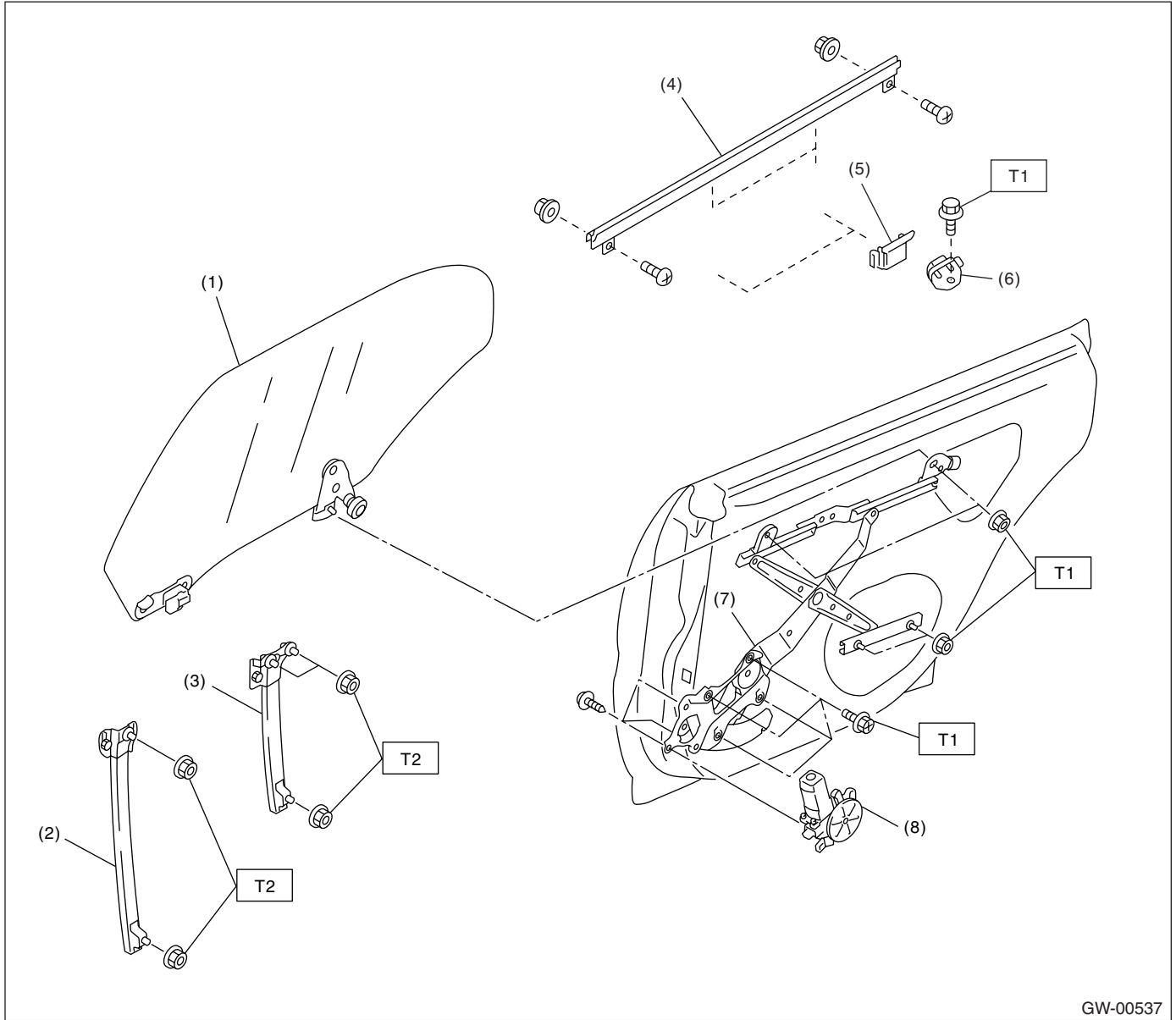

GW-00537

- | | |
|-----------------------|------------------------|
| (1) Glass | (5) Stabilizer (Outer) |
| (2) Door sash (Front) | (6) Stabilizer (Inner) |
| (3) Door sash (Rear) | (7) Regulator ASSY |
| (4) Weather strip | (8) Motor ASSY |

Tightening torque: N·m (kgf·m, ft·lb)

T1: 7.4 (0.75, 5.5)

T2: 13.7 (1.4, 10.1)

General Description

GLASS/WINDOWS/MIRRORS

5. MIRROR

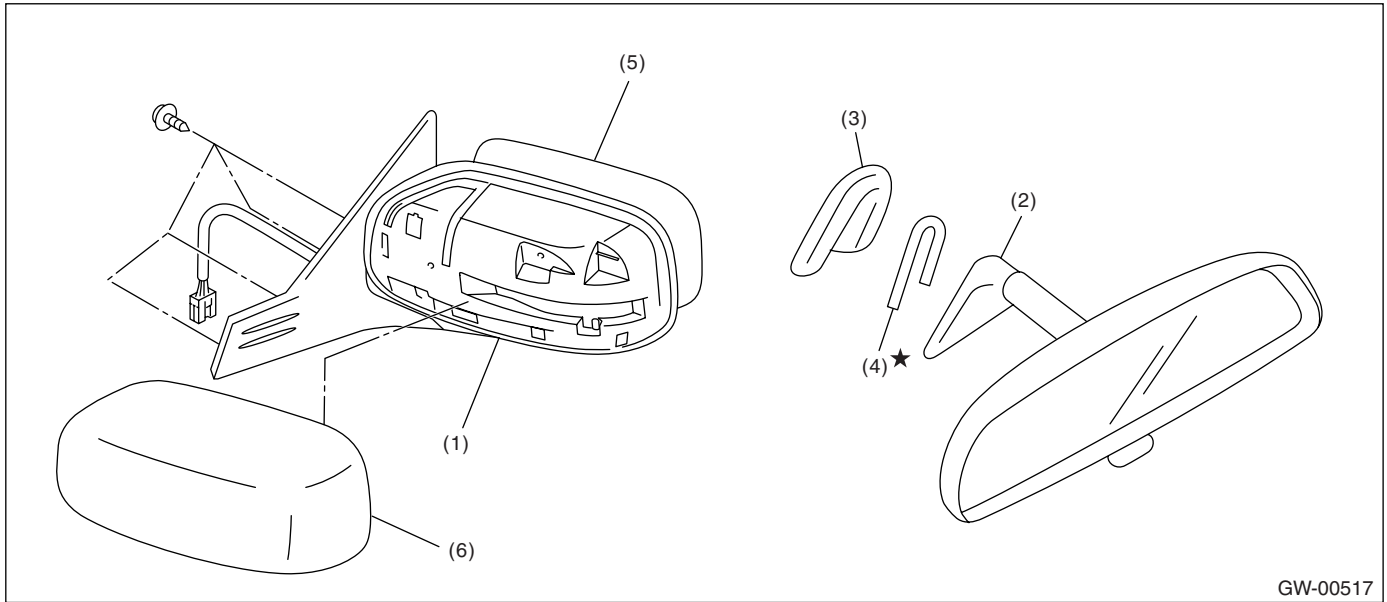

- (1) Outer mirror
- (2) Inner rearview mirror

- (3) Mount
- (4) Spring

- (5) Mirror
- (6) Scalp cap

B: CAUTION

- When the electrical connectors are disconnected, always conduct an operational check after connecting them again.
- Avoid impact and damage to glass.

General Description

GLASS/WINDOWS/MIRRORS

C: PREPARATION TOOL

1. SPECIAL TOOL

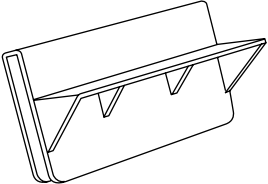
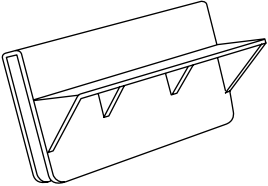
ILLUSTRATION	TOOL NUMBER	DESCRIPTION	REMARKS
 ST61299AE000	61299AE000	SPACER	Used for adjusting the upper end position of front door glass. (Glass thickness: 5 mm (0.197 in))
 ST61299AE010	61299AE010	SPACER	Used for adjusting the upper end position of rear door glass. (Glass thickness: 4 mm (0.157 in))

2. GENERAL TOOL

TOOL NAME	REMARKS
Circuit tester	Used for checking voltage and continuity.
Piano wire	Used for window glass removal.
Windshield knife	Used for window glass removal.

Power Window System

GLASS/WINDOWS/MIRRORS

2. Power Window System

A: WIRING DIAGRAM

<Ref. to WI-144, Power Window System.>

B: INSPECTION

Symptom	Repair order
All power windows do not operate.	(1) Fuse (SBF-6) (2) Power window circuit breaker (3) Power window relay (4) Wiring harness
One window does not operate.	(1) Power window main switch (2) Power window sub switch (3) Power window motor (4) Wiring harness
"Window Lock" does not operate.	Power window main switch

3. Power Window Control Switch

A: REMOVAL

1. MAIN SWITCH

- 1) Disconnect the ground cable from battery.
- 2) Using a flat tip screwdriver, remove the screw cover.

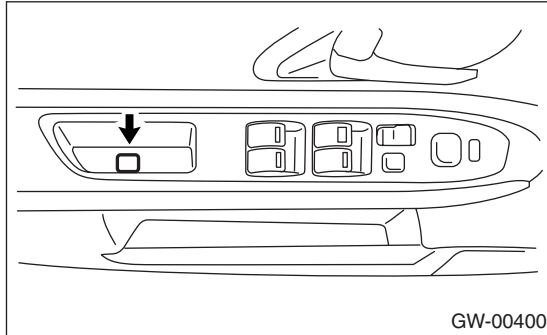

- 3) Loosen the screw to remove the power window main switch.

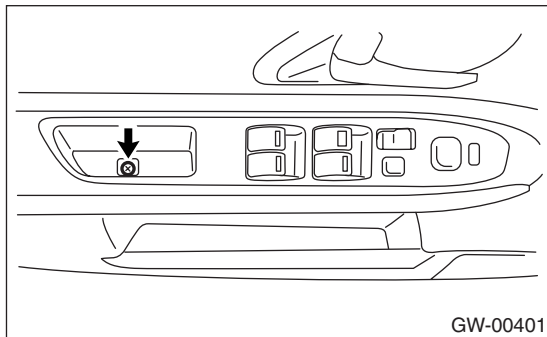

- 4) Disconnect the connector.

2. SUB SWITCH

- 1) Disconnect the ground cable from battery.
- 2) Remove the screw which secures switch panel.

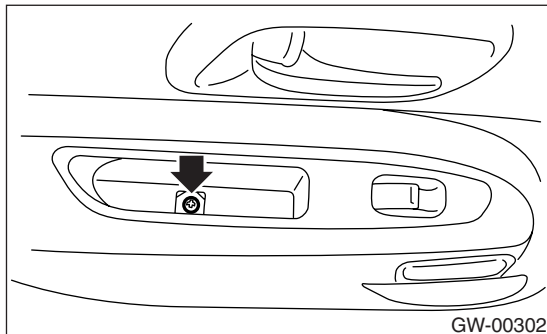

- 3) Remove the switch panel.

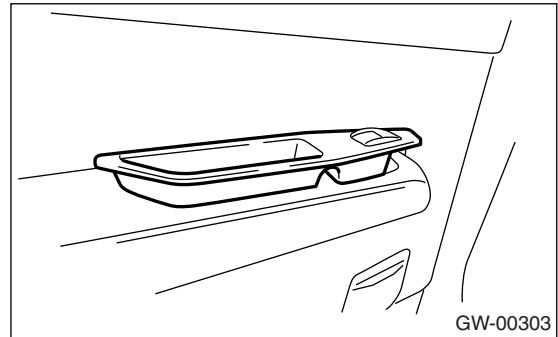

- 4) Disconnect the connector.

B: INSTALLATION

1. MAIN SWITCH

Install in the reverse order of removal.

2. SUB SWITCH

Install in the reverse order of removal.

C: INSPECTION

1. MAIN SWITCH

- 1) Remove the main switch. <Ref. to GW-9, REMOVAL, Power Window Control Switch.>
- 2) Turn the window lock switch to UNLOCK.
- 3) Connect the battery and main switch as shown in the figure below.

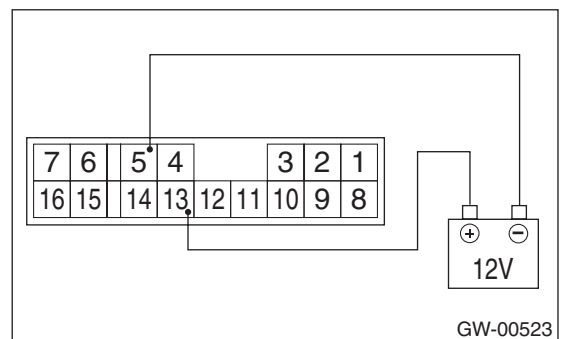

Power Window Control Switch

GLASS/WINDOWS/MIRRORS

4) Measure the main switch resistance.

	Switch position	Terminal No.	Standard
Driver's side	UP	13 and 2, 1 and 5	Less than 1 Ω
	OFF	1 and 5 2 and 5	Less than 1 Ω
	DOWN	13 and 1, 2 and 5	Less than 1 Ω
	AUTO DOWN	13 and 1, 2 and 5	Less than 1 Ω
Front passenger's side	UP	13 and 6, 7 and 5	Less than 1 Ω
	OFF	5 and 6 5 and 7	Less than 1 Ω
	DOWN	13 and 7, 6 and 5	Less than 1 Ω
Rear LH	UP	11 and 13, 10 and 5	Less than 1 Ω
	OFF	5 and 11 5 and 10	Less than 1 Ω
	DOWN	13 and 10, 11 and 5	Less than 1 Ω
Rear RH	UP	13 and 16, 15 and 5	Less than 1 Ω
	OFF	5 and 15 5 and 16	Less than 1 Ω
	DOWN	13 and 15, 16 and 5	Less than 1 Ω

5) If NG, replace the main switch.

2. SUB SWITCH

1) Remove the sub switch. <Ref. to GW-9, REMOVAL, Power Window Control Switch.>

2) Measure the sub switch resistance.

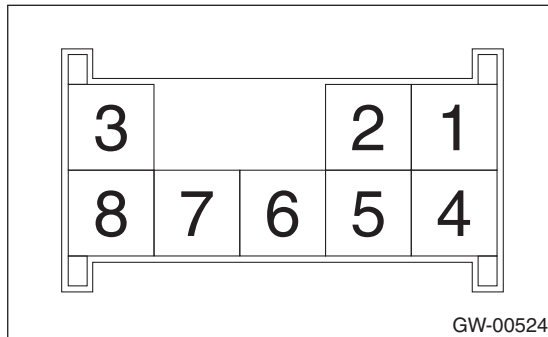

	Switch position	Terminal No.	Standard
Front passenger's side & rear	UP	8 and 5, 4 and 7	Less than 1 Ω
	OFF	6 and 5, 4 and 7	Less than 1 Ω
	DOWN	8 and 7, 6 and 5	Less than 1 Ω

3) If NG, replace the sub switch.

4. Front Door Glass

A: REMOVAL

- 1) Remove the front door trim. <Ref. to EI-41, REMOVAL, Front Door Trim.>
- 2) Remove the sealing cover. <Ref. to EB-17, REMOVAL, Front Sealing Cover.>
- 3) Remove the outer mirror assembly. <Ref. to GW-18, REMOVAL, Outer Mirror Assembly.>
- 4) Remove the mirror gusset.

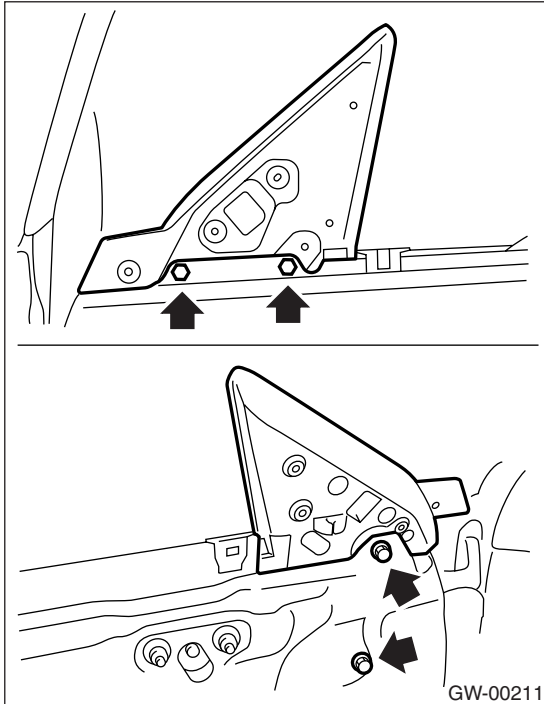

- 5) Remove the stabilizer (Inner) and stabilizer (Outer).

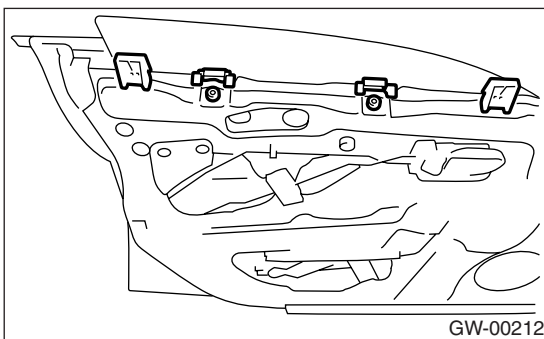

- 6) Remove the screw at the rear end of weather strip, and remove weather strip.

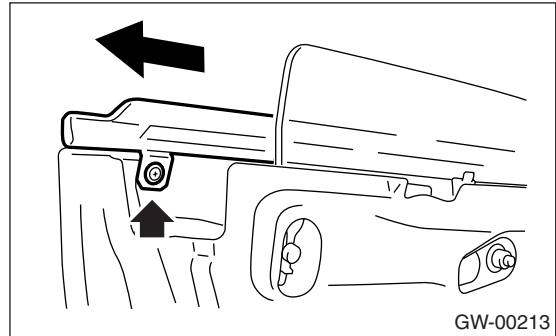

- 7) Operate the power window switch to move the glass to position shown in the figure, and then remove the two nuts from service holes.

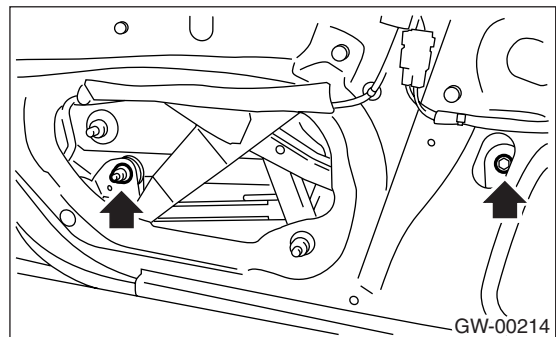

- 8) Take out the door glass.

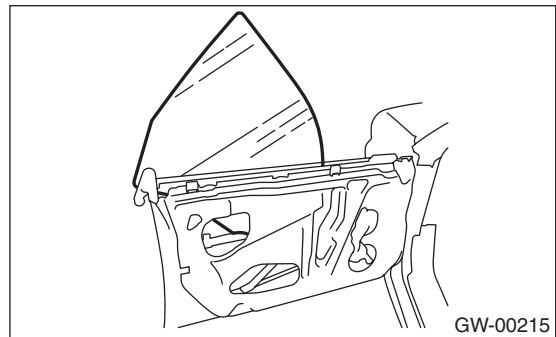

CAUTION:

- Do not turn the regulator in closing direction after removal of the glass. Otherwise gear may be disengaged.
- Avoid impact and damage to the glass.

B: INSTALLATION

- 1) Install in the reverse order of removal.

CAUTION:

Make sure the slider (front) and roller (rear) of glass is placed securely in sash.

- 2) Adjust the front door glass. <Ref. to GW-12, ADJUSTMENT, Front Door Glass.>

Front Door Glass

GLASS/WINDOWS/MIRRORS

Tightening torque:

Refer to **COMPONENT in General Description.** <Ref. to **GW-4, FRONT DOOR GLASS, COMPONENT, General Description.**>

C: ADJUSTMENT

NOTE:

Before adjustment, ensure that all adjusting nuts of stabilizer (inner), upper stopper, and sash are loosened and door glass is raised so that it is in contact with weather strip.

1) Temporarily tighten one adjusting bolt on one side of rear sash at the midpoint of slotted hole in the inner panel.

2) Temporarily tighten the regulator B-channel in a position at the top of slotted hole.

3) Lower the door glass 10 to 15 mm (0.39 to 0.59 in) from fully closed position. While applying outward pressure of 45.0 ± 5.0 N (4.5 ± 0.5 kgf, 9.9 ± 1.1 lbf) (F) to the upper edge of glass above midpoint of stabilizer (Outer), press the stabilizer (Inner) at pressure of 30 ± 5 N (3.0 ± 0.5 kgf, 6.6 ± 1.1 lbf) to the glass, then secure it.

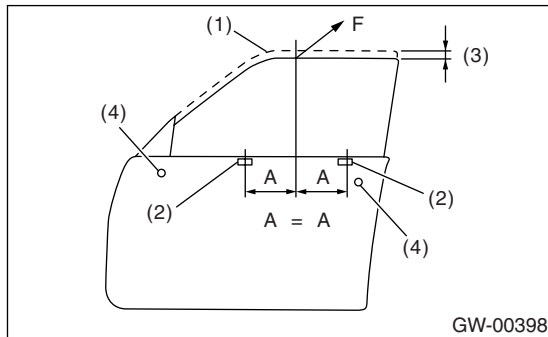

- (1) Full close position
- (2) Stabilizer (Outer)
- (3) 10 — 15 mm (0.39 — 0.59 in)
- (4) Upper stopper

4) For adjustment of clearance between front glass and center pillar cover, loosen the nuts (A), and move the glass sash back and forward until clearance becomes the value shown.

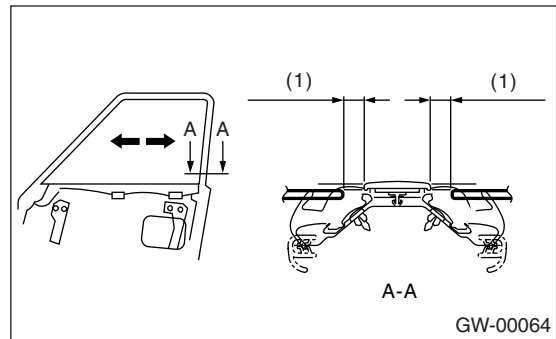
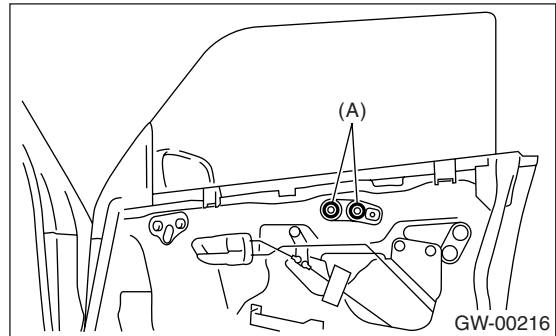

- (1) 12 mm (0.472 in)

5) For adjustment of upper and lower ends of center pillar, loosen the adjusting nut (A) of B-channel (B).

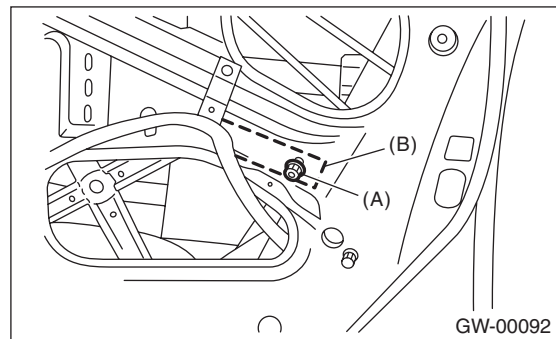

6) Adjust so that the upper and lower ends of center pillar are the same size.

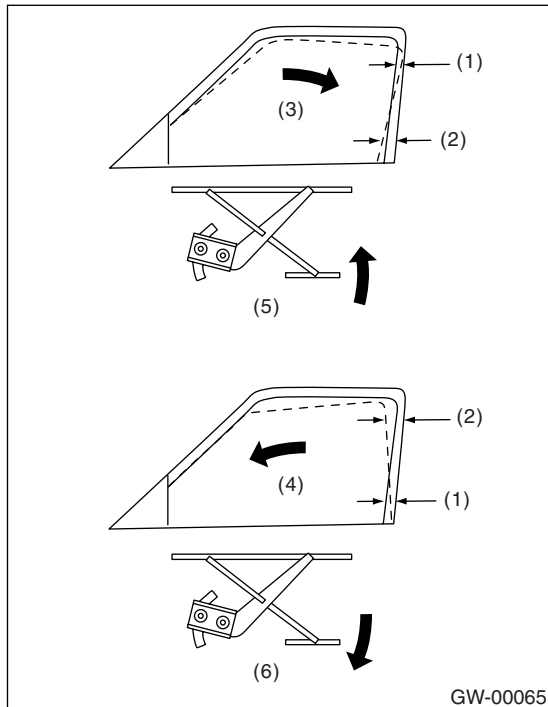

- (1) Narrow
- (2) Wide
- (3) Glass tilts too far rearward
- (4) Glass tilts too far forward
- (5) Raise B channel
- (6) Lower B channel

7) For glass stroke adjustment, set the ST on glass and close the door, raise glass until positional relationship between glass and weather strip becomes as shown. And secure the glass so that the upper stopper lightly touches the glass holder.

ST 61299AE000 SPACER (For front door glass of thickness 5 mm (0.197 in))

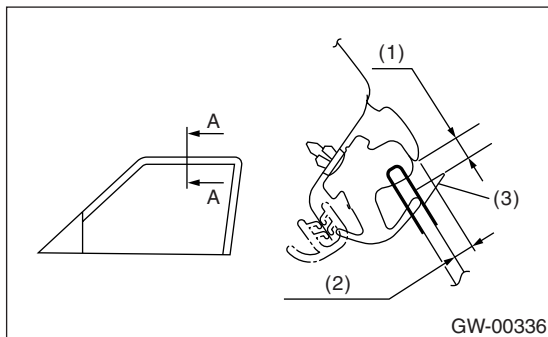

- (1) 2.7 — 4.3 mm (0.106 — 0.169 in)
- (2) 6 mm (0.236 in)
- (3) Special Tool

For preventing wind noise, adjust the glass at the position where tip of gusset is raised up a little.

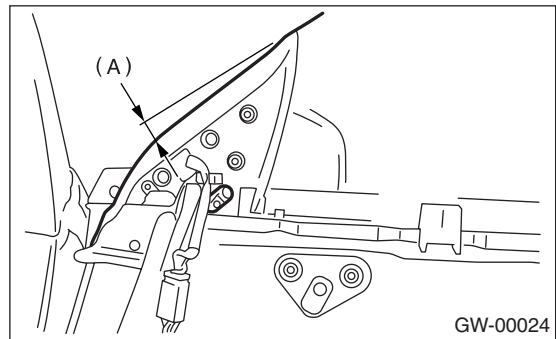

(A) 0 — 1.5 mm (0 — 0.059 in)

8) After stabilizer adjustment, carry out the glass crimp adjustment. First, visually ensure positional relationship between retainer & molding and glass of the roof side, and then begin with rear sash adjustment. Set the ST on glass, and then adjust two adjusting bolts alternately step by step to obtain dimensions shown below (cross-section A).

ST 61299AE000 SPACER (For front door glass of thickness 5 mm (0.197 in))

NOTE:

If two nuts are loosened at the same time, sash moves back and forth. Therefore, when one nut is adjusted, leave the other secured.

9) Make the same adjustment of two adjusting bolts of rear sash.

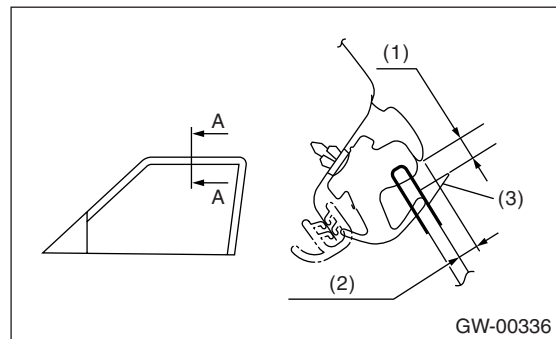

- (1) 2.7 — 4.3 mm (0.106 — 0.169 in)
- (2) 6 mm (0.236 in)
- (3) Special Tool

Front Door Glass

GLASS/WINDOWS/MIRRORS

NOTE:

Do not tilt the sash bracket to inner panel during adjustment. Otherwise smooth regulator operation cannot be achieved.

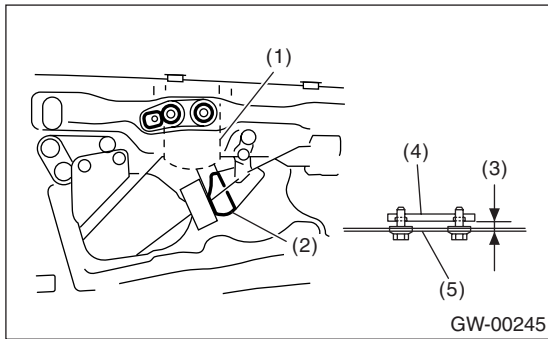

- (1) Sash bracket
- (2) Rear sash
- (3) Adjust a line parallel
- (4) Sash
- (5) Inner panel

10) Make adjustment of front sash in the same manner as that of rear sash.

NOTE:

Although front and rear sashes must, as a rule, be adjusted in the same manner, in some door installation, the adjustment in a different manner may be required. However, adjustment of one sash to the maximum amount and the other to the minimum amount is not permitted. Such adjustment may result in application of excessive load to regulator.

11) After adjustments, tighten the nuts.

12) After adjustment to glass, close the door. If there is a gap between outer lip of gusset and glass surface, adjust the gap with adjusting bolt (A) in lower fitting part of the gusset to prevent generation of wind noise.

13) During adjustments, loosen the other three clamping bolts.

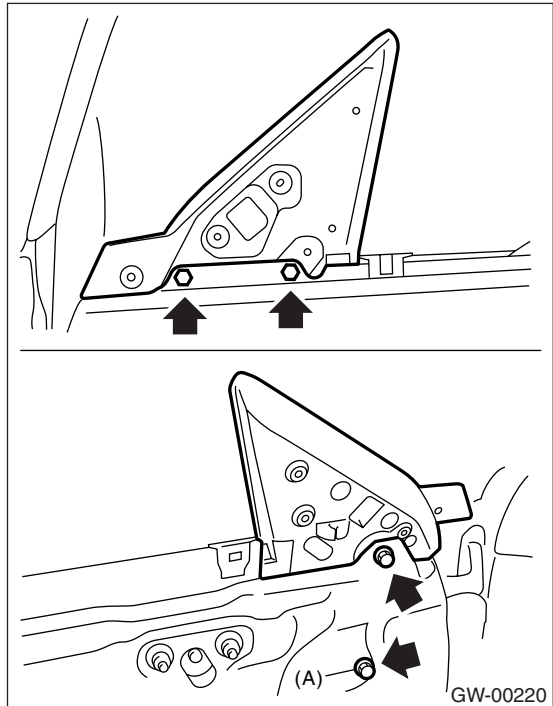

14) After adjustment, tighten the bolts and nuts.

5. Front Regulator and Motor Assembly

A: REMOVAL

- 1) Remove the door glass. <Ref. to GW-11, REMOVAL, Front Door Glass.>
- 2) Loosen the nuts to remove the rear sash.

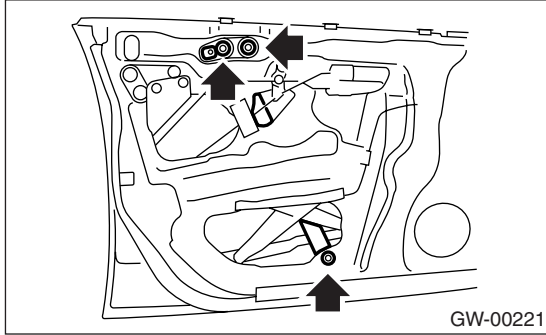

- 3) Disconnect the motor connector.
- 4) Loosen the four bolts and two nuts to remove the regulator assembly.

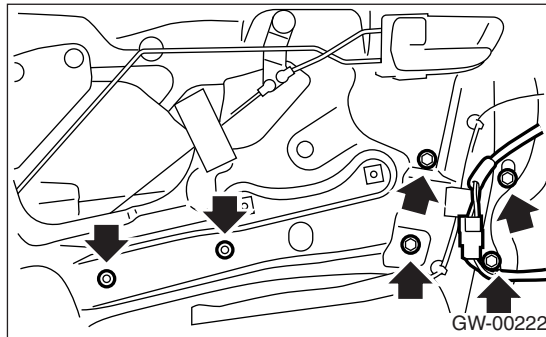

- 5) Loosen the screw to remove motor assembly.

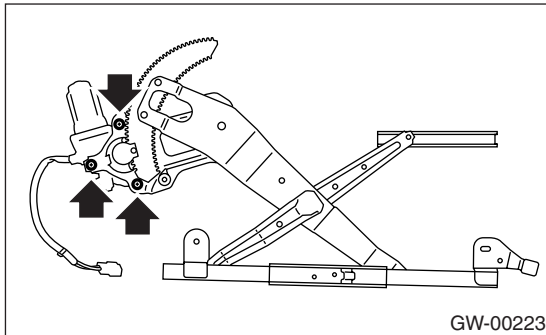

B: INSTALLATION

- 1) Install in the reverse order of removal.
- 2) Adjust the front door glass. <Ref. to GW-12, ADJUSTMENT, Front Door Glass.>

Tightening torque:

Refer to COMPONENT in General Description. <Ref. to GW-4, FRONT DOOR GLASS, COMPONENT, General Description.>

C: INSPECTION

- 1) Make sure the power window motor rotates properly when battery voltage is applied to the terminals of motor connector.
- 2) Change polarity of battery connections to terminals to ensure the motor rotates in reverse direction.

Remote Control Mirror System

GLASS/WINDOWS/MIRRORS

6. Remote Control Mirror System

A: WIRING DIAGRAM

<Ref. to WI-150, Remote Control Mirror System.>

B: INSPECTION

Symptom	Repair order
All functions do not operate.	(1) Fuse (F/B No. 1) (F/B No. 4) (F/B No. 19) (2) Mirror switch (3) Wiring harness
One side of the mirror motor does not operate.	(1) Mirror switch (2) Mirror motor (3) Wiring harness
Mirror heater does not operate.	(1) Mirror switch (2) Mirror heater (3) Wiring harness

7. Scalp Cap

A: REPLACEMENT

- 1) Turn the mirror downward.
- 2) Insert a thin screw driver, push the clip part of scalp cap, and remove the scalp cap.

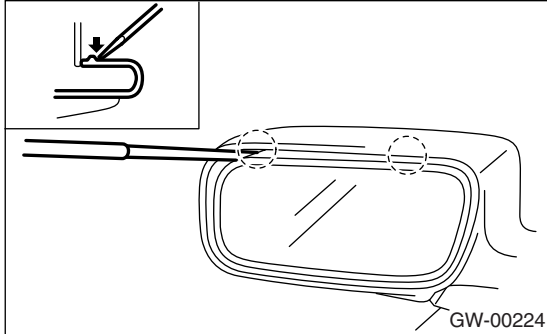

- 3) Insert the claw at the bottom of scalp cap into outer mirror.

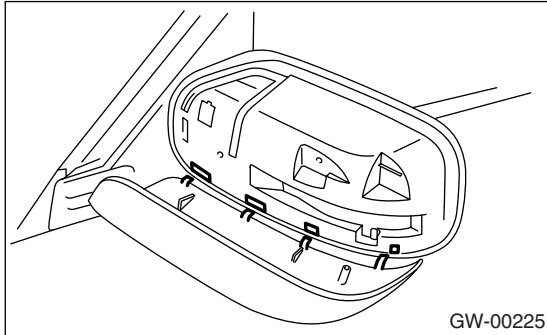

- 4) Install the scalp cap securely.

Outer Mirror Assembly

GLASS/WINDOWS/MIRRORS

8. Outer Mirror Assembly

A: REMOVAL

- 1) Remove the door trim. <Ref. to EI-41, REMOVAL, Front Door Trim.>
- 2) Remove the mirror gusset cover.

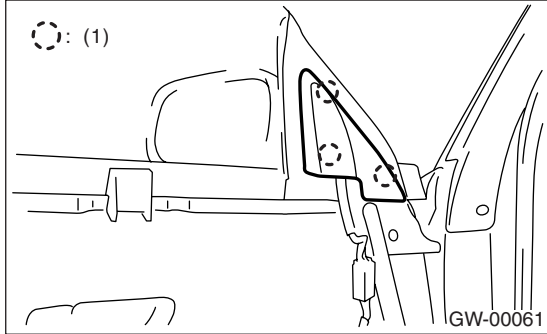

(1) Hook pawl

C: INSPECTION

Check to ensure that the outer mirror moves properly when battery voltage is applied to terminals.

- Mirror heater not-equipped model:

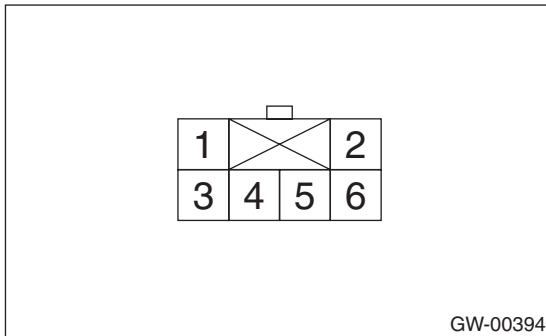

- 3) Disconnect the outer mirror connector.
- 4) Remove the screws to remove the outer mirror assembly.

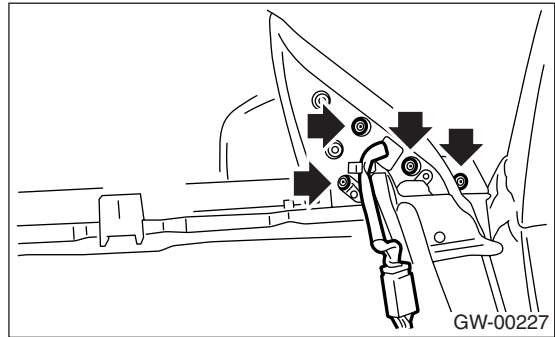

B: INSTALLATION

Install in the reverse order of removal.

Switch position	Terminal No.
OFF	—
UP	4 (+) and 6 (-)
DOWN	6 (+) and 4 (-)
LEFT	5 (+) and 6 (-)
RIGHT	6 (+) and 5 (-)

If NG, replace the outer mirror.

- Mirror heater equipped model:

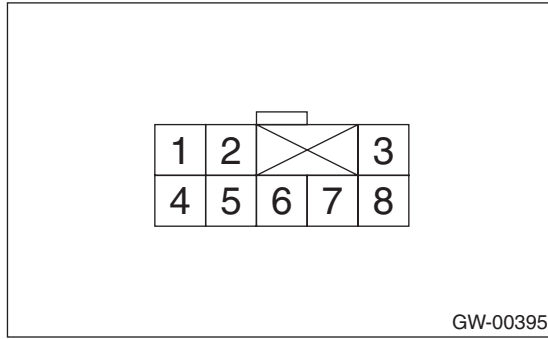

Switch position	Terminal No.
OFF	—
UP	6 (+) and 8 (-)
DOWN	8 (+) and 6 (-)
LEFT	7 (+) and 8 (-)
RIGHT	8 (+) and 7 (-)

If NG, replace the outer mirror.

9. Outer Mirror

A: REPLACEMENT

- 1) Remove the outer mirror assembly. <Ref. to GW-18, REMOVAL, Outer Mirror Assembly.>
- 2) Warm the area around the mirror holder (A) with a hair drier until the edges of the mirror holder become soft (about 2 or 3 minutes with a 1,000 W drier).
- 3) Use a flat tip screwdriver without sharp edges to lift the mirror out of the mirror holder (A).

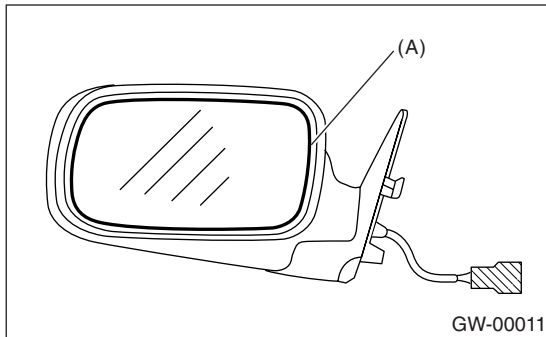

- 4) Disconnect the mirror heater connector. (Model with mirror heater)
- 5) Warm the area around the mirror holder with a hair drier until the edges of the mirror holder become soft (about 2 or 3 minutes with a 1,000 W drier).
- 6) Connect the mirror heater connector. (Model with mirror heater)
- 7) Remove the backing of the new double-stick tape, and push the mirror in to install it.

NOTE:

Unless the mirror holder is warmed sufficiently, the mirror holder edges may be damaged or the mirror cracked.

10. Remote Control Mirror Switch

A: REMOVAL

Refer to Power Window Control Switch for removal procedure, because the remote control mirror switch is installed in power window control switch panel. <Ref. to GW-9, REMOVAL, Power Window Control Switch.>

B: INSTALLATION

Refer to Power Window Control Switch for installation procedure, because the remote control mirror switch is installed in power window control switch panel. <Ref. to GW-9, INSTALLATION, Power Window Control Switch.>

C: INSPECTION

Move the rearview mirror switch to each position and check continuity between terminals.

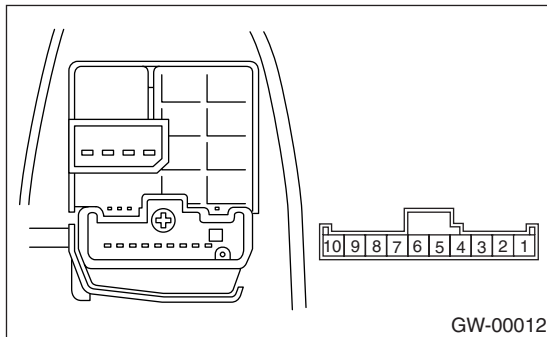

Change over switch right position:

Switch position	Terminal No.	Standard
OFF	—	More than 1 MΩ
UP	8 and 3, 6 and 7	Less than 1 Ω
DOWN	8 and 6, 3 and 7	Less than 1 Ω
LEFT	8 and 2, 6 and 7	Less than 1 Ω
RIGHT	8 and 6, 2 and 7	Less than 1 Ω

Change over switch left position:

Switch position	Terminal No.	Standard
OFF	—	More than 1 MΩ
UP	8 and 4, 6 and 7	Less than 1 Ω
DOWN	8 and 6, 4 and 7	Less than 1 Ω
LEFT	8 and 5, 6 and 7	Less than 1 Ω
RIGHT	8 and 6, 5 and 7	Less than 1 Ω

If NG, replace the switch.

11. Rear Door Glass

A: REMOVAL

- 1) Remove the rear door trim. <Ref. to EI-42, REMOVAL, Rear Door Trim.>
- 2) Remove the sealing cover. <Ref. to EB-20, REMOVAL, Rear Sealing Cover.>
- 3) Remove the stabilizer.

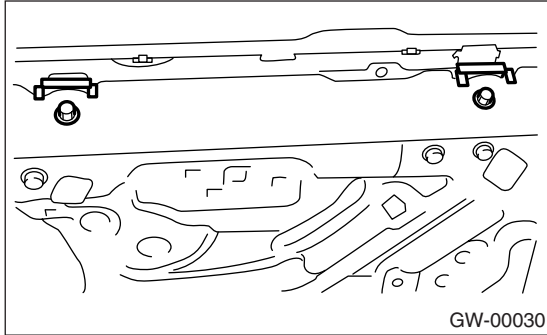

- 4) Remove the front end and rear end of weather strip.

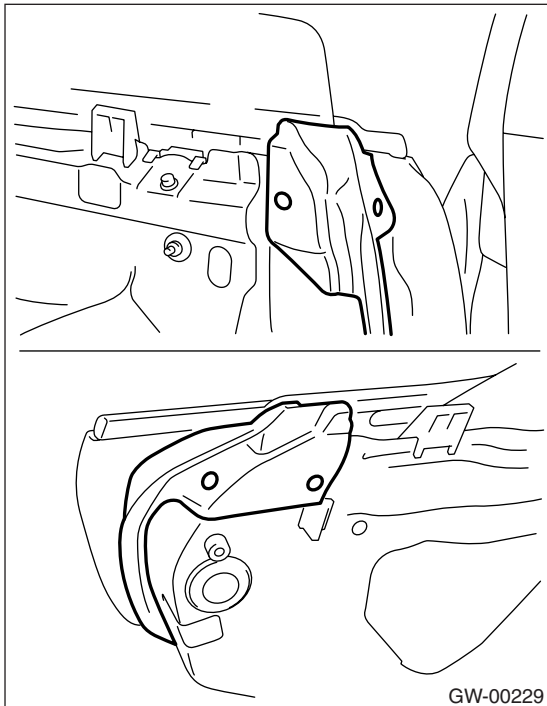

- 5) Remove the two screws to remove the weather strip outer.

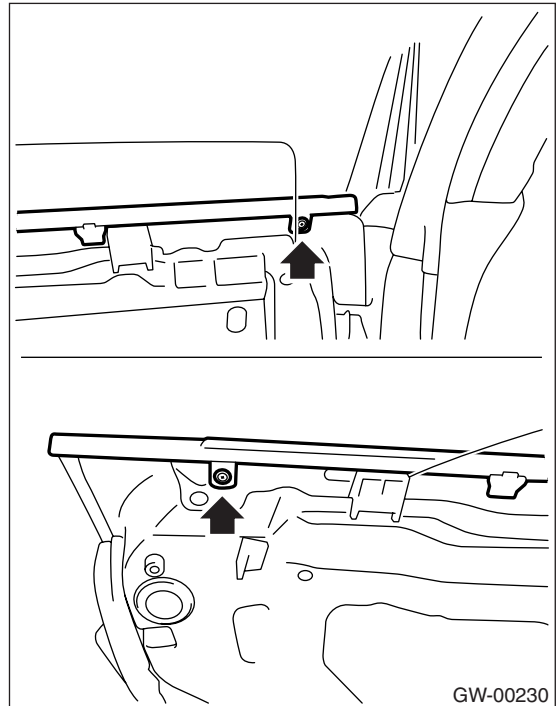

- 6) Operate the power window switch to move the glass to position shown in the figure, and then remove two nuts from service holes.

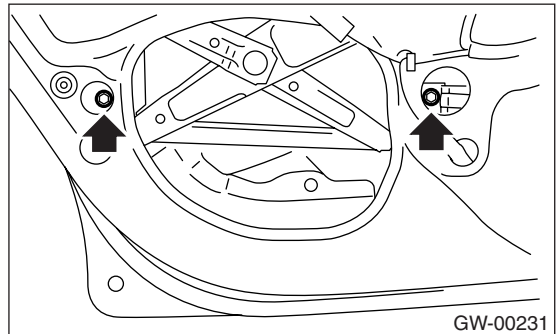

- 7) Remove the two rear sash installation nuts, and then move the rear sash backward.
- 8) Remove the glass.

CAUTION:
Avoid impact and damage to the glass.

B: INSTALLATION

- 1) Install in the reverse order of removal.

NOTE:

Make sure the slider (front) and roller (rear) of glass stay is placed securely in front and rear sash.

- 2) Adjust the rear door glass. <Ref. to GW-23, ADJUSTMENT, Rear Door Glass.>

Tightening torque:

Refer to **COMPONENT** in **General Description**. <Ref. to GW-5, REAR DOOR GLASS, COMPONENT, General Description.>

C: ADJUSTMENT

NOTE:

The rear door glass, as a rule, should be adjusted in the same manner as front door glass, although they are different in dimension. Special notes for the rear glass are given below.

1) Adjust the glass position using the following dimensions as a guide line.

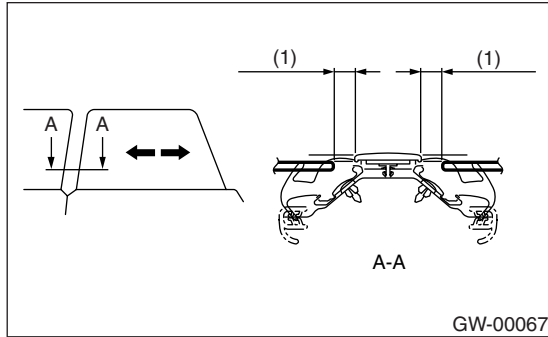

(1) 12 mm (0.472 in)

NOTE:

- If the dimensions are smaller than the given dimensions, glass may get caught in weather strip during lifting/lowering operation. In the worst case, it may cause the glass not to be opened fully.
- After adjustment, move the glass up and down to check whether it is caught.

2) Set the ST on glass, and then adjust the contact degree of glass using the following dimensions as a guide line.

ST 61299AE010 SPACER (For rear door glass of thickness 4 mm (0.157 in))

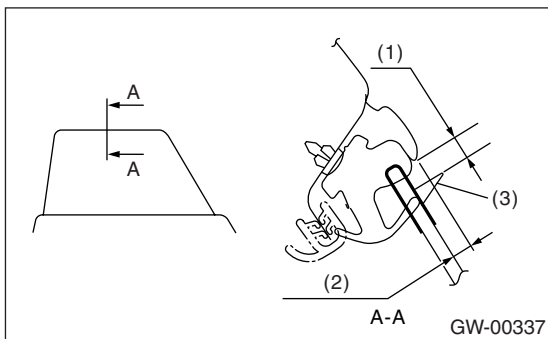

(1) 3.7 — 5.3 mm (0.146 — 0.209 in)

(2) 6 mm (0.236 in)

(3) Special Tool

NOTE:

- If the contact degree of rear glass is higher than necessary, glass may get caught in weather strip of center pillar corner, resulting in early wear of weather strip. Be careful when adjusting.

12. Rear Regulator and Motor Assembly

A: REMOVAL

- 1) Remove the rear door glass. <Ref. to GW-22, REMOVAL, Rear Door Glass.>
- 2) Remove the front sash.
- 3) Disconnect the motor connector.
- 4) Remove the four bolts and two nuts to remove regulator assembly.

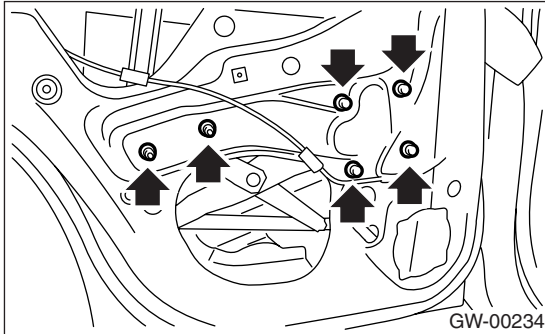

- 5) Remove the screws to remove motor assembly.

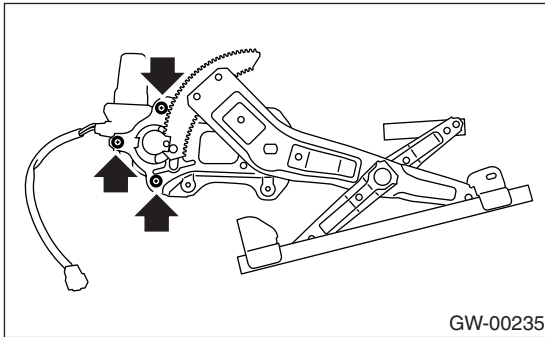

B: INSTALLATION

- 1) Install in the reverse order of removal.
- 2) Adjust the rear door glass. <Ref. to GW-23, ADJUSTMENT, Rear Door Glass.>

Tightening torque:

Refer to COMPONENT in General Description. <Ref. to GW-5, REAR DOOR GLASS, COMPONENT, General Description.>

C: INSPECTION

- 1) Make sure that the power window motor rotates properly when battery voltage is applied to terminals of motor connector.
- 2) Change polarity of battery connections to terminals to ensure that the motor rotates in reverse direction.

13. Windshield Glass

A: REMOVAL

1. USING WINDSHIELD KNIFE

- 1) Disconnect the wiper deicer connector. (Model with wiper deicer)
- 2) Remove the cowl panel. <Ref. to EI-34, REMOVAL, Cowl Panel.>
- 3) Remove the glass molding.
- 4) Tape the body side of the circumference of windshield glass for protection.
- 5) Apply sufficient amount of soapy water to the adhesive layer.
- 6) Insert the windshield knife into the adhesive layer.
- 7) While holding the knife edge and windshield glass edge at a right angle, move the windshield knife in parallel to the windshield glass edge along face and edge of windshield glass to cut the adhesive layer.

NOTE:

- Do not twist the windshield knife.
- Cutting of adhesive layer shall be started with wider gap between windshield glass and body.

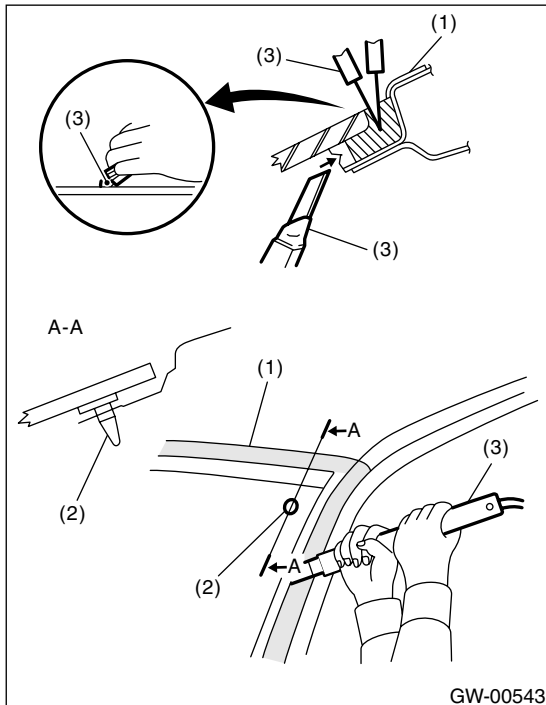

- (1) Protective tape
- (2) Locating pin
- (3) Windshield knife

- Because the locating pins are bonded to corners of glass, use piano wire to cut the pin.

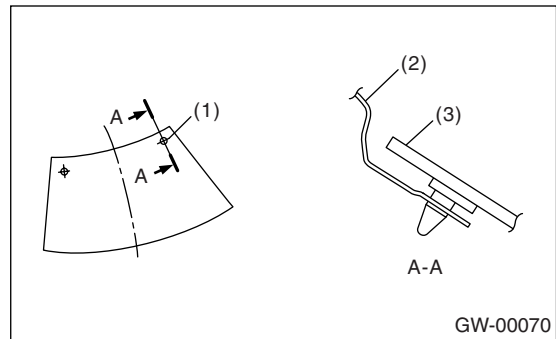

- (1) Locating pin
- (2) Body panel
- (3) Windshield glass

2. USING PIANO WIRE

- 1) Disconnect the wiper deicer connector. (Model with wiper deicer)
- 2) Remove the cowl panel. <Ref. to EI-34, REMOVAL, Cowl Panel.>
- 3) Remove the glass molding.
- 4) Tape the body side of circumference of windshield glass for protection.
- 5) Make a hole in adhesive layer using a drill or knife.
- 6) Pass the piano wire through hole, and attach securely both the piano wire ends to pieces of wood.

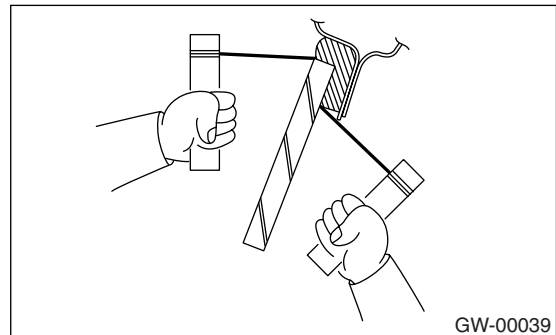

- 7) Pull the wire ends alternately to cut off the adhesive layer.

CAUTION:

- Do not tightly pull the piano wire against the windshield glass edge.
- Be careful not to damage the interior and exterior parts.
- Do not cross piano wires. Otherwise they may be cut.
- After removing the area near instrument panel, attach a protection plate to it. Use extreme care when removing.

Windshield Glass

GLASS/WINDOWS/MIRRORS

B: INSTALLATION

1) Clean the external circumference of windshield glass with alcohol or white gasoline.

2) Remove the adhesive layer on the body using cutter knife to obtain smooth face 2 mm (0.08 in) thick.

CAUTION:

Be careful not to damage the body and paint surface.

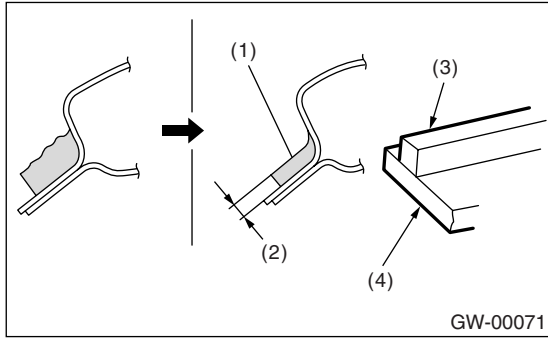

- (1) Adhesive
- (2) 2 mm (0.08 in)
- (3) Dam rubber
- (4) Glass

3) Clean the body with alcohol or white gasoline to remove thoroughly chips, dusts, and dirt from body face.

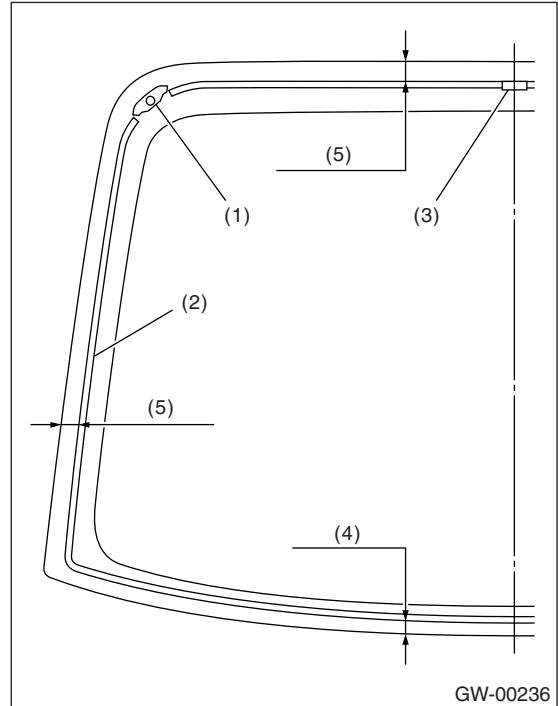

- (1) Locating pin
- (2) Dam rubber
- (3) Fastener
- (4) 15 mm (0.591 in)
- (5) 11 mm (0.433 in)

4) Install the dam rubber.

5) Fit the mark (B) on molding to the notch (A) of glass side, and install the molding to the whole glass edge.

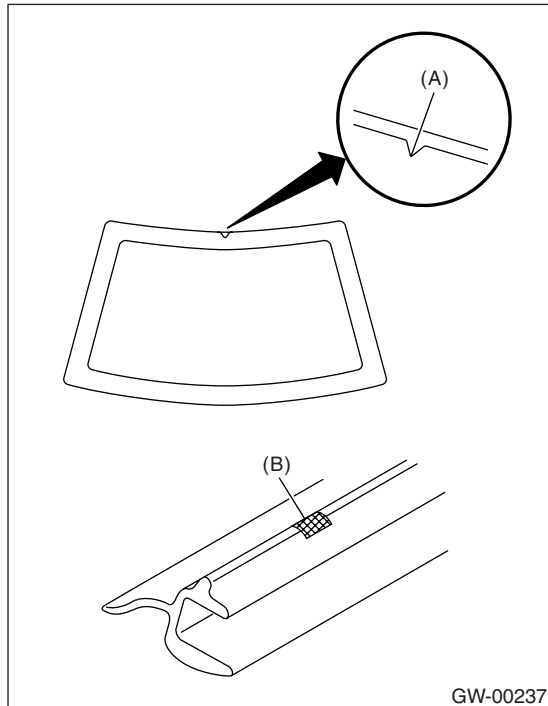

GW-00237

6) Apply two kinds of primer to the adhesive layer of glass using sponge.

Glass primer:

Dow Automotive

ESSEX U-401 (for undercoat) and ESSEX U-402 (for overcoat) or equivalent

7) Apply primer to adhesive layer of body.

Painted surface primer:

Dow Automotive

ESSEX U-413 or equivalent

NOTE:

- Primer once attached to painted surface of the body and internal trim is hard to wipe off. Mask the circumference of such areas.
- Let the primer dry for about ten minutes before installing the glass.

- Do not touch the surface coated with primer.

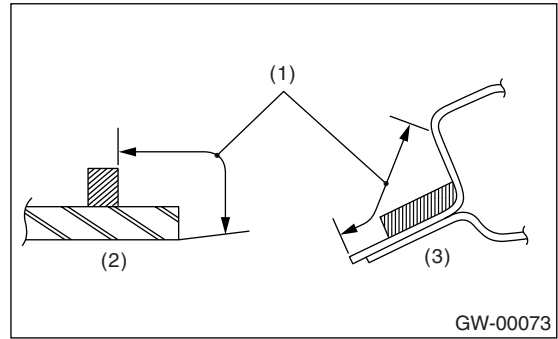

GW-00073

- (1) Application of primer
- (2) Glass side
- (3) Body side

8) Cut off the cartridge nozzle tip as shown and set it in sealant gun.

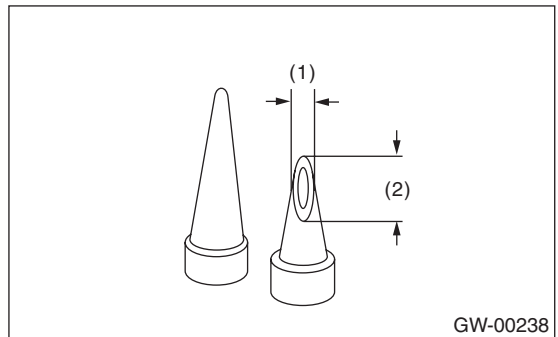

GW-00238

- (1) 10 mm (0.39 in)
- (2) 15 mm (0.59 in)

9) Apply adhesive to the glass end surface as shown.

Adhesive:

Dow Automotive

ESSEX U-400HV or equivalent

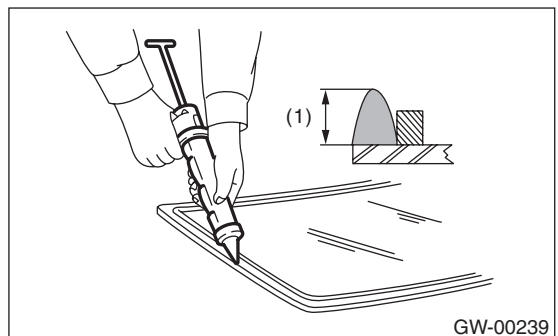

GW-00239

- (1) 12 — 15 mm (0.47 — 0.59 in)

Windshield Glass

GLASS/WINDOWS/MIRRORS

10) Fit the locating pins using suction rubber cup to install the windshield glass.

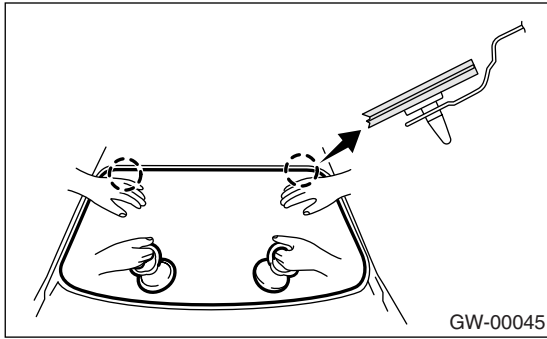

- 11) Lightly press the windshield glass for tight fit.
12) Make flush the adhesive surface jugged out using spatula.
13) Connect the wiper deicer connector. (Model with wiper deicer)
14) After completion of all work, allow the vehicle to stand for about 24 hours.

NOTE:

- When the door is opened/closed after glass is bonded, always lower the door glass and then open/close it carefully.
- Move the vehicle slowly.
- For minimum drying time and time the vehicle must be left standing before driving after bonding, follow the instructions or instruction manual from adhesive manufacturer.

15) After curing of adhesive, pour water on external surface of vehicle to check that there are no water leaks.

NOTE:

When a vehicle is returned to the user, tell him or her that the vehicle should not be subjected to heavy impact for at least three days.

16) Install the cowl panel. <Ref. to EI-34, INSTALLATION, Cowl Panel.>

14.Rear Gate Glass

A: REMOVAL

- 1) Remove the rear wiper motor. <Ref. to WW-18, REMOVAL, Rear Wiper Motor.>
- 2) Disconnect the electrical connector from rear defogger terminal.
- 3) Remove the glass in the same procedure as for windshield glass. <Ref. to GW-25, REMOVAL, Windshield Glass.>

B: INSTALLATION

- 1) Apply adhesive in the same procedure as for windshield glass. <Ref. to GW-26, INSTALLATION, Windshield Glass.>
- 2) Insert the glass locating pin into the rear gate hole, and after pushing on the area around the locating pin to secure it, push lightly all around the area to seal it.
- 3) About one hour after installation, conduct a water leak test.

NOTE:

- When the door is opened/closed after glass is bonded, always lower the door glass and then open/close it carefully.
 - Move the vehicle slowly.
 - For minimum drying time and time the vehicle must be left standing before driving after bonding, follow the instructions or instruction manual from adhesive manufacturer.
 - When a vehicle is returned to the user, tell him or her that the vehicle should not be subjected to heavy impact for at least three days.
- 5) Connect the rear defogger terminals.
 - 6) Install the rear wiper. <Ref. to WW-18, INSTALLATION, Rear Wiper Motor.>

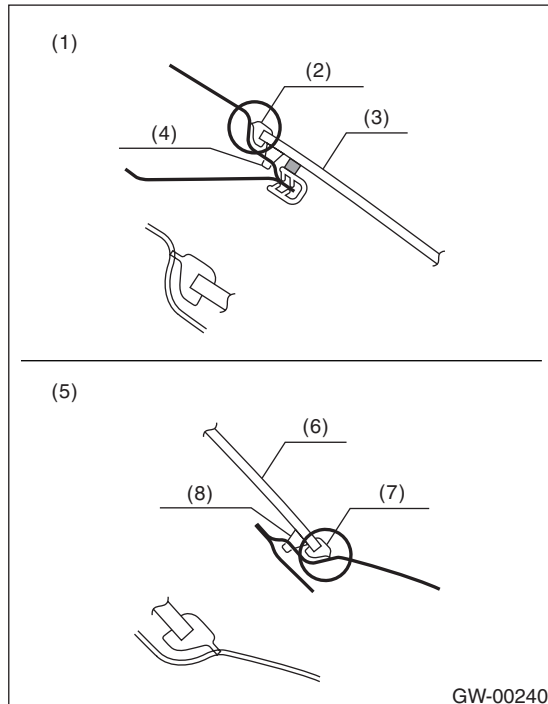

- (1) Upper side
- (2) Molding
- (3) Glass
- (4) Adhesive
- (5) Lower side
- (6) Glass
- (7) Molding
- (8) Adhesive

- 4) After completion of all work, allow the vehicle to stand for about 24 hours.

15. Rear Window Glass

A: REMOVAL

- 1) Disconnect the electrical connectors from rear defogger terminals and antenna terminal.
- 2) Remove the glass in the same procedure as for windshield glass. <Ref. to GW-25, REMOVAL, Windshield Glass.>

B: INSTALLATION

- 1) Install the dam rubber.

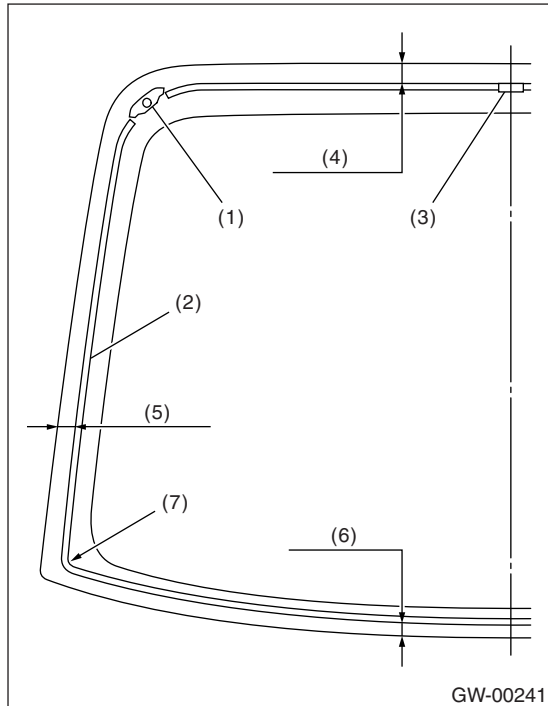

- (1) Locating pin
- (2) Dam rubber
- (3) Fastener
- (4) 14.5 mm (0.571 in)
- (5) 8 mm (0.315 in)
- (6) 22 mm (0.866 in)
- (7) R20

- 2) Install the glass in the same procedure as for windshield glass. <Ref. to GW-26, INSTALLATION, Windshield Glass.>
- 3) Connect the rear defogger terminals and antenna terminal.
- 4) After completion of all work, allow the vehicle to stand for about 24 hours.

NOTE:

- When the door is opened/closed after glass is bonded, always lower the door glass and then open/close door carefully.
- Move the vehicle slowly.

- For minimum drying time and time the vehicle must be left standing before driving after bonding, follow the instructions or instruction manual from adhesive manufacturer.

- 5) After curing of adhesive, pour water on external surface of vehicle to check that there are no water leaks.

NOTE:

When a vehicle is returned to user, tell him or her that the vehicle should not be subjected to heavy impact for at least three days.

16.Rear Window Defogger System

A: WIRING DIAGRAM

<Ref. to WI-148, Rear Defogger System.>

B: INSPECTION

Symptom	Repair order
Rear window defogger does not operate.	(1) Fuse (M/B No. 1) (F/B No. 17) (2) Rear defogger relay (3) Rear defogger timer (4) Defogger switch (5) Rear defogger condenser (6) Defogger wire (7) Wiring harness

Rear Window Defogger

GLASS/WINDOWS/MIRRORS

17.Rear Window Defogger

A: INSPECTION

CAUTION:

When wiping stain on glass off with cloth, use a dry and soft cloth and move it along the heat wire to avoid damage to heat wire.

- 1) Turn the ignition switch to ON.
- 2) Turn the defogger switch to ON.
- 3) Wrap the tips of tester pins with aluminum foil to avoid damage to heat wire.

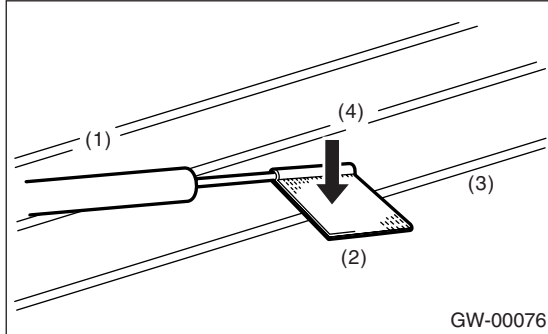

- (1) Tester probe
- (2) Aluminum foil
- (3) Heat wire
- (4) Press

4) Measure the voltage at wire center with DC voltmeter.

Standard voltage:
Approx. 6 V

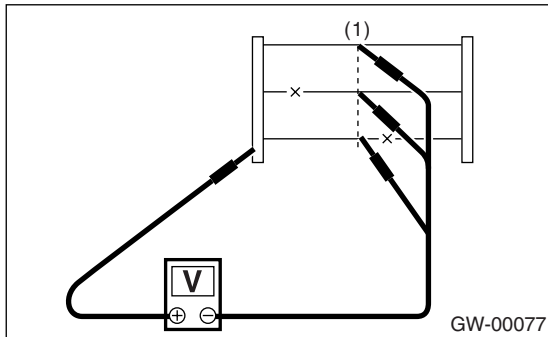

- (1) Wire center

Voltage	Criteria
Approx. 6 V	OK
Approx. 12 V or 0 V	Broken

NOTE:

- If the measured value is 12 volts, heat wire is open between wire center and positive (+) end.
- If zero volt, heat wire is open between wire center and ground.

5) Apply positive lead of voltmeter to positive terminal of voltmeter, and then move the negative lead along the wire up to negative terminal end. If voltage changes from zero to several volts during movement of lead, heat wire is open at the voltage change point.

B: REPAIR

- 1) Clean the broken portion with alcohol or white gasoline.
- 2) Mask both side of wire with thin film.
- 3) Apply conductive silver composition (DUPONT No. 4817) to broken portion.

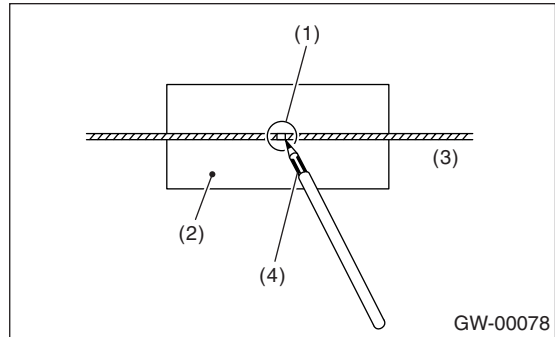

- (1) Broken portion
- (2) Masking thin film
- (3) Broken wire
- (4) Conductive silver composition (DUPONT No. 4817)

4) After repair, check the wire.

18.Rear Quarter Glass

A: REMOVAL

Remove the glass in the same procedure as for windshield glass. <Ref. to GW-25, REMOVAL, Windshield Glass.>

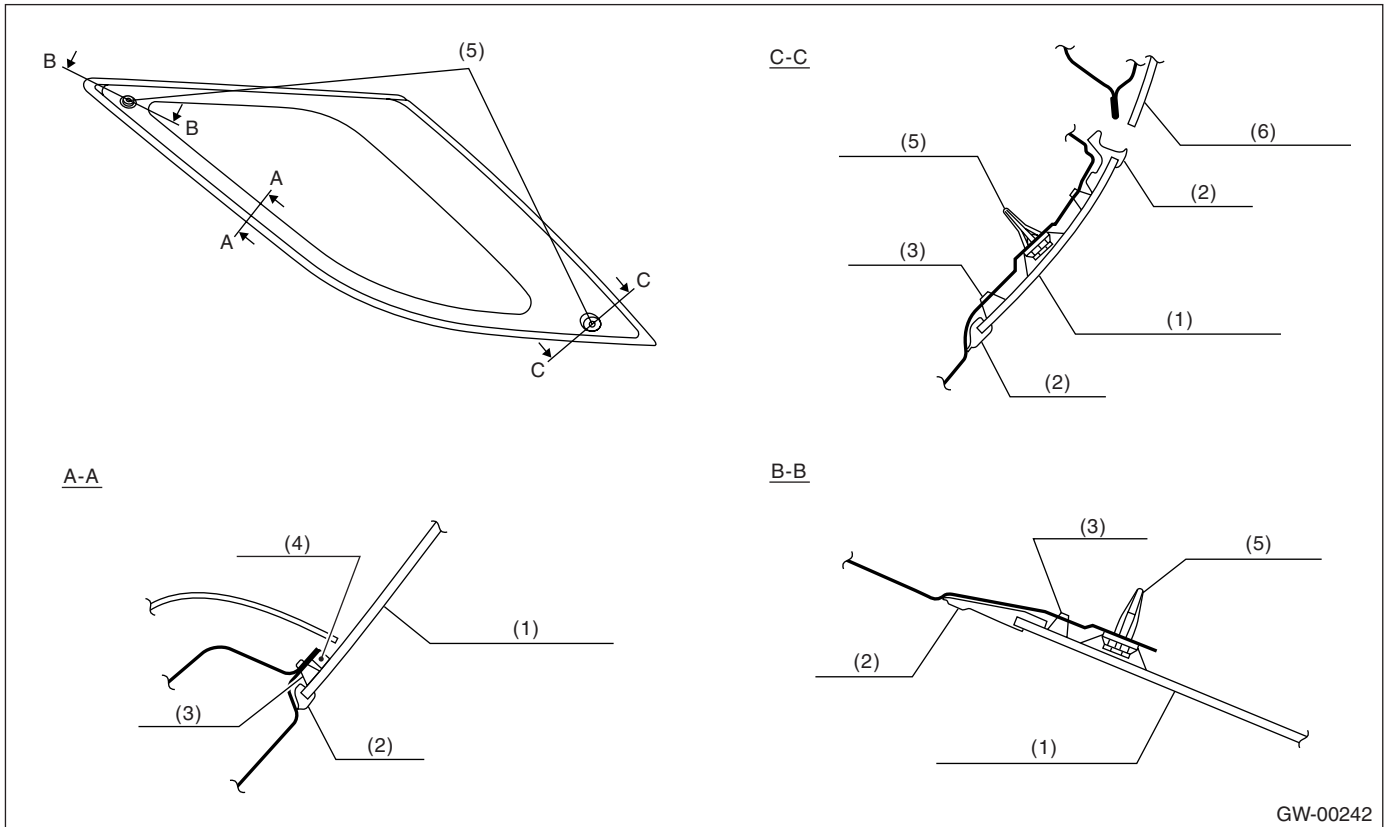

GW-00242

- | | | |
|------------------------|----------------|---------------------|
| (1) Rear quarter glass | (3) Adhesive | (5) Locating pin |
| (2) Molding | (4) Dam rubber | (6) Rear gate glass |

B: INSTALLATION

1) Cut off the nozzle tip as shown in the figure.

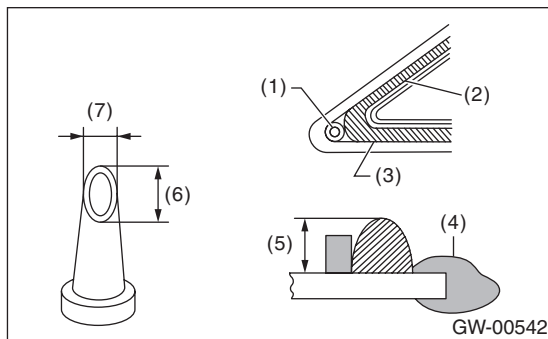

GW-00542

- | |
|---------------------------------|
| (1) Locating pin |
| (2) Dam rubber |
| (3) Adhesive |
| (4) Molding |
| (5) 12 — 15 mm (0.47 — 0.59 in) |
| (6) 15 mm (0.59 in) |
| (7) 10 mm (0.39 in) |

2) Install the glass in the same procedure as for windshield glass. <Ref. to GW-26, INSTALLATION, Windshield Glass.>

3) After completion of all work, allow the vehicle to stand for about 24 hours.

NOTE:

- When the door is opened/closed after glass is bonded, always lower the door glass and then open/close it carefully.
- Move the vehicle slowly.
- For minimum drying time and time the vehicle must be left standing before driving after bonding, follow the instructions or instruction manual from adhesive manufacturer.

4) After curing of adhesive, pour water on external surface of vehicle to check that there are no water leaks.

NOTE:

When a vehicle is returned to user, tell him or her that the vehicle should not be subjected to heavy impact for at least three days.

19.Sun Roof Glass

A: REMOVAL

<Ref. to SR-5, REMOVAL, Glass Lid.>

B: INSTALLATION

<Ref. to SR-5, INSTALLATION, Glass Lid.>

C: ADJUSTMENT

<Ref. to SR-5, ADJUSTMENT, Glass Lid.>

20.Rearview Mirror

A: REMOVAL

NOTE:

The spring cannot be reused. Prepare a new spring before removal.

1) Turn the mirror base 90° clockwise or counter-clockwise to remove it.

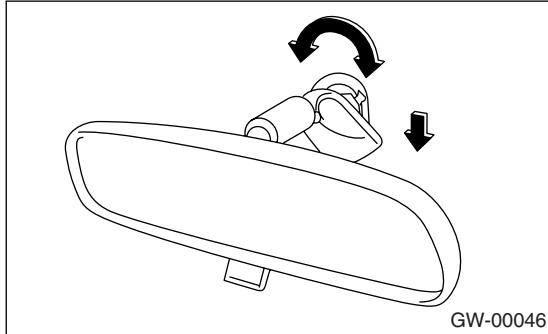

2) Remove the spring from mirror base.

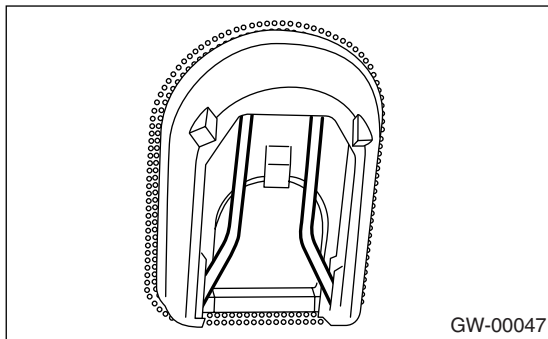

CAUTION:

Be careful not to damage the mirror surface.

3) If the mirror base is damaged, remove the mirror base using piano wire or spatula, etc.

CAUTION:

Be careful not to damage the windshield glass.

B: INSTALLATION

1) If removing the mirror base, remove the remaining adhesive thoroughly, and then fit the mirror base to mark on windshield glass to install.

Adhesive:

REPAIR KIT IN MR (Part No. 65029FC000) or equivalent

2) Verify that the mirror base is adhered securely, and then install the spring.

3) Install in the reverse order of removal.

C: INSPECTION

Make sure the mirror is not damaged.

Make sure the spring is not deteriorated.

21. Wiper Deicer System

A: INSPECTION

Refer to INSPECTION under Rear Window Defogger. <Ref. to GW-32, INSPECTION, Rear Window Defogger.>

B: REPAIR

Refer to REPAIR under Rear Window Defogger. <Ref. to GW-32, REPAIR, Rear Window Defogger.>

22. Wiper Deicer Switch

A: REMOVAL

Remove the driver side lower cover, and then remove the wiper deicer switch.

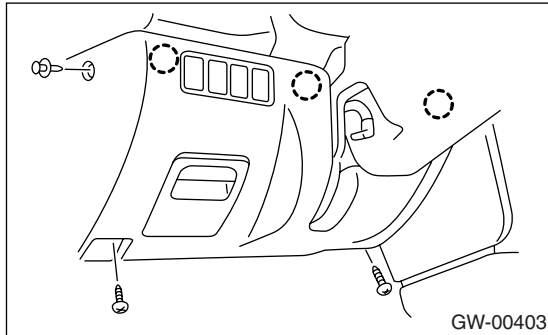

B: INSTALLATION

Install in the reverse order of removal.

C: INSPECTION

Move wiper deicer switch to each position and check continuity between terminals.

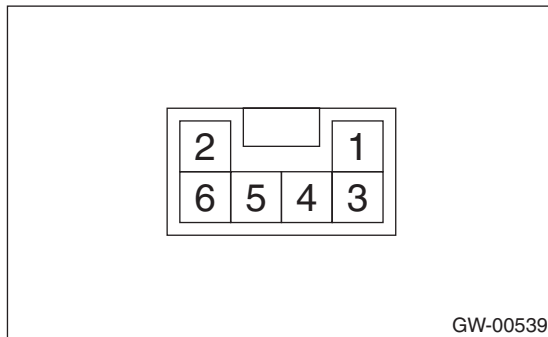

Switch position	Terminal No.	Standard
OFF	3 and 5	More than 1 MΩ
ON	3 and 5	Less than 1 Ω

If NG, replace the switch.

