

HVAC SYSTEM (AUTO A/C) (DIAGNOSTICS)

Basic Diagnostic Procedure

HVAC SYSTEM (AUTO A/C) (DIAGNOSTICS)

1. Basic Diagnostic Procedure

A: PROCEDURE

	Step	Check	Yes	No
1	START INSPECTIONS. 1) Perform the pre-inspection. <Ref. to AC(diag)-3, INSPECTION, General Description.> 2) Perform the self-diagnosis. <Ref. to AC(diag)-8, OPERATION, Diagnostic Chart for Self-Diagnosis.>	Does the self-diagnosis operate?	Go to step 2.	<Ref. to AC(diag)-11, A/C OR SELF-DIAGNOSIS SYSTEMS DO NOT OPERATE, Diagnostics for A/C System Malfunction.>
2	CONFIRM MALFUNCTION PART. Confirm the malfunction part with self-diagnosis.	Can the malfunction part be confirmed?	Repair the malfunction part according to each diagnostics chart.	Go to step 3.
3	CHECK COMPARTMENT TEMPERATURE. 1) Turn the A/C switch ON. 2) Set the temperature control dial to maximum cold position. 3) Check the compartment temperature changes.	Is the compartment temperature changed?	Go to step 4.	<Ref. to AC(diag)-15, COMPARTMENT TEMPERATURE DOES NOT CHANGE, OR A/C SYSTEM DOES NOT RESPOND PROMPTLY., Diagnostics for A/C System Malfunction.>
4	CHECK A/C SYSTEM RESPONSE. Change the temperature setting, and check the response of A/C system.	Does the A/C system respond quickly?	A/C system is OK.	<Ref. to AC(diag)-15, COMPARTMENT TEMPERATURE DOES NOT CHANGE, OR A/C SYSTEM DOES NOT RESPOND PROMPTLY., Diagnostics for A/C System Malfunction.>

General Description

HVAC SYSTEM (AUTO A/C) (DIAGNOSTICS)

2. General Description

A: CAUTION

1) Never connect the battery in reverse polarity. The Auto A/C control module will be destroyed instantly.

2) Do not disconnect the battery cables while the engine is running.

A large counter electromotive force will be generated in the alternator, and this voltage may damage electronic parts such as auto A/C control module.

3) Before disconnecting the connectors of each sensor and the auto A/C control module, be sure to turn off the ignition switch.

The auto A/C control module may be damaged.

4) Every A/C-related part is a precision part. Do not drop them.

5) Airbag system wiring harness is routed near the A/C control panel (auto A/C control module) and junction box.

CAUTION:

- Airbag system connectors are colored yellow. Do not use electrical test equipment on these circuits.

- Be careful not to damage the airbag system wiring harness when servicing the A/C control panel (auto A/C control module) and junction box.

B: INSPECTION

Before performing diagnosis, check the following items which might affect A/C system problems.

1. BATTERY

1) Measure the battery voltage and specific gravity of electrolyte.

Standard voltage: 12 V

Specific gravity: Above 1.260

2) Check the condition of the fuses for A/C system power supply and other fuses.

3) Check the condition of the harnesses and harness connectors connection.

2. ASPIRATOR HOSE

1) Turn the ignition switch to ON and push the A/C switch.

2) Turn the temperature control dial to maximum hot position.

3) Turn the air flow control dial to "DEF" position.

4) Turn the fan speed control dial to MAX speed position.

5) Firmly hold a thin paper (b) in front of the in-vehicle sensor suction port (a) for the auto A/C control module and check that the paper moves towards the port indicating that air is being sucked into the port.

NOTE:

Ensure the paper does not get sucked into the port.

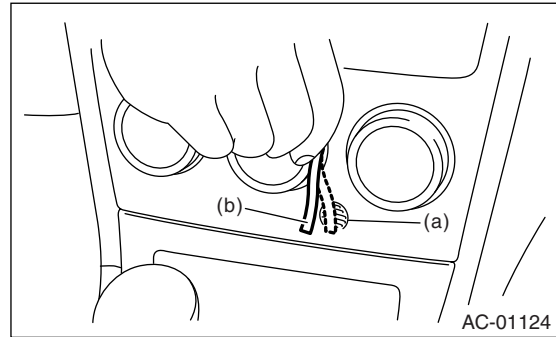

6) If the paper does not move at all, remove the auto A/C control module <Ref. to AC-31, REMOVAL, Control Unit (Auto A/C Model).> and check for improper connection of the aspirator hose (A), auto A/C control module and heater unit, and secure as necessary.

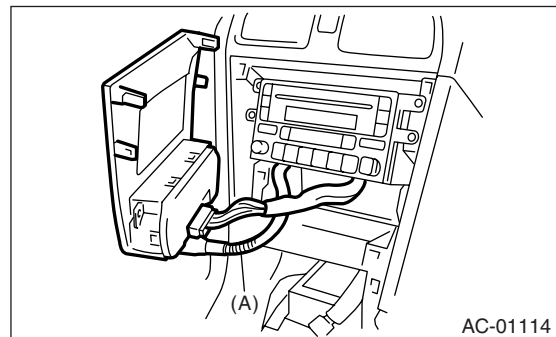

3. A/C LINE

Check the connection for A/C line (A) and lower side high-pressure pipe.

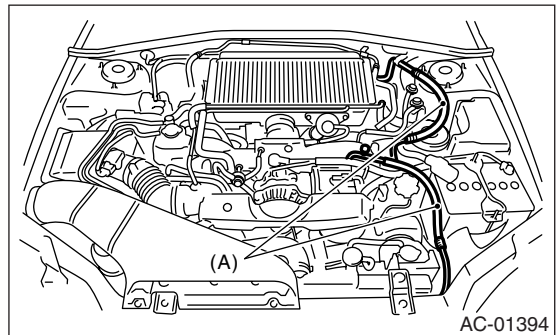

4. CONTROL LINKAGE

- 1) Check the state of mode door linkage.
- 2) Check the state of air mix door linkage.
- 3) Check the state of intake door linkage.

General Description

HVAC SYSTEM (AUTO A/C) (DIAGNOSTICS)

5. CONTROL SWITCHES

Start and warm-up the engine completely.

1) Inspection using switches

No.	Item to be checked	Switch position	Judgment standard
1	Air flow control dial	Turn the dial to the right.	Outlet opening (mode) switches AUTO → VENT → BILEVEL → HEAT → DEF/HEAT → DEF each time turning the dial.
2	Fan speed control dial	Turn the dial to the right	Fan speed switches OFF → AUTO → 1st — 25th each time turning the dial.
3	FRESH/RECIRC switch	Press the FRESH/RECIRC switch.	Inlet opening switches RECIRC → FRESH each time pressing the switch.
		Press the FRESH/RECIRC switch longer (more than 1.0 seconds).	LED blinks twice, and switches to AUTO.
4	A/C switch	Turn the A/C switch to ON with the fan speed control dial position other than OFF.	LED comes on, and the compressor will be operated.
		Press the A/C switch longer (more than 1.0 seconds).	LED blinks twice, and switches to AUTO.
5	Auto function Operate from 1) in order.	1) Set the following dials and switches to AUTO. <ul style="list-style-type: none"> • Air flow control dial • Fan speed control dial • FRESH/RECIRC switch • A/C switch 2) Turn the temperature control dial to the left fully, to set to the maximum cool position.	<ul style="list-style-type: none"> • Outlet air temperature: COOL • Fan speed: MAX • Outlet opening: VENT • Inlet opening: Internal air • Compressor: AUTO
		3) Turn the temperature control dial to the right slowly, to change the setting gradually to the maximum hot position.	<ul style="list-style-type: none"> • Outlet air temperature: COOL → HOT • Fan speed: AUTO • Outlet opening: AUTO • Inlet opening: AUTO • Compressor: AUTO
		4) Turn the temperature control dial to the right fully, to set to the maximum hot position.	<ul style="list-style-type: none"> • Outlet air temperature: HOT • Fan speed: MAX • Outlet opening: HEAT • Inlet opening: External air • Compressor: AUTO
6	Defroster interlock	Turn the air flow control dial to DEF or DEF/HEAT position.	<ul style="list-style-type: none"> • Outlet air temperature: AUTO • Fan speed: AUTO • Outlet opening: DEF or DEF/HEAT • Inlet opening: External air • Compressor: ON
7	Rear window defogger switch	Press the rear window defogger switch.	LED comes on.

2) Inspection of illumination control

No.	Item to be checked	Switch operation	Judgment standard
1	Illumination	Turn the lighting switch to ON.	Illumination comes on. LED goes dim if it has been illuminated.

Electrical Component Location

HVAC SYSTEM (AUTO A/C) (DIAGNOSTICS)

3. Electrical Component Location

A: LOCATION

1. ENGINE COMPARTMENT

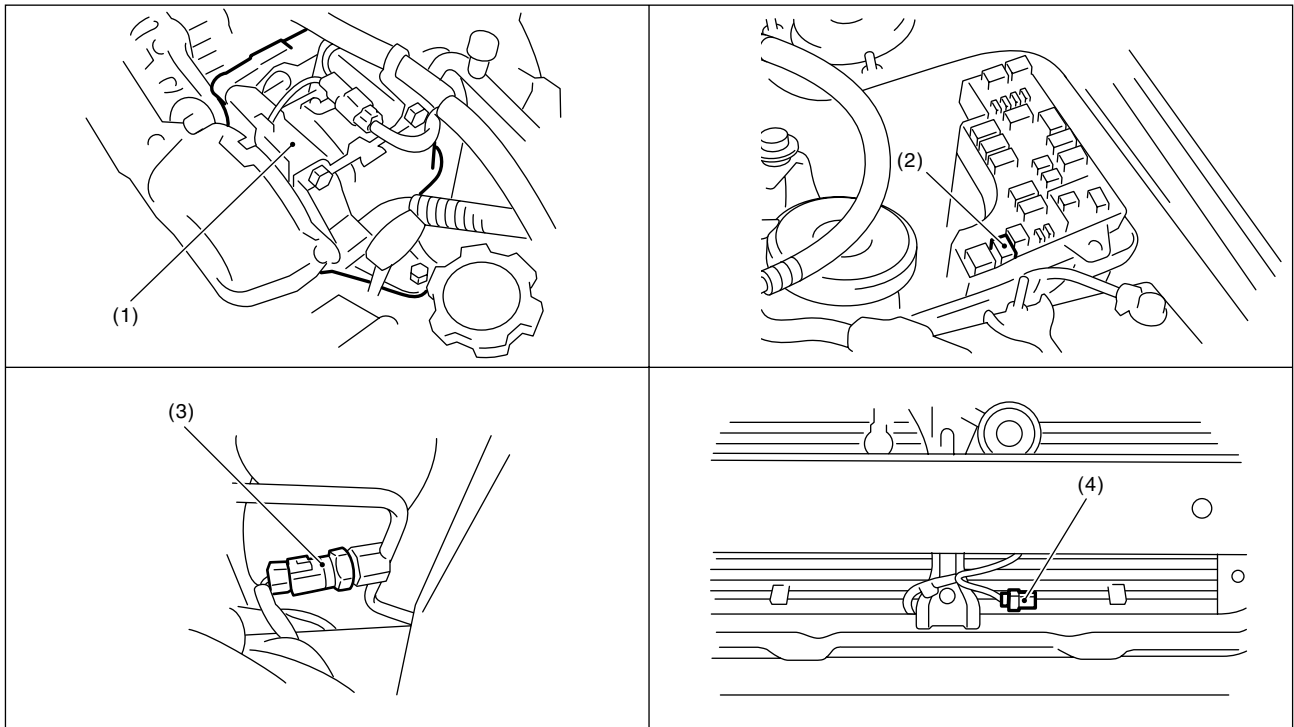
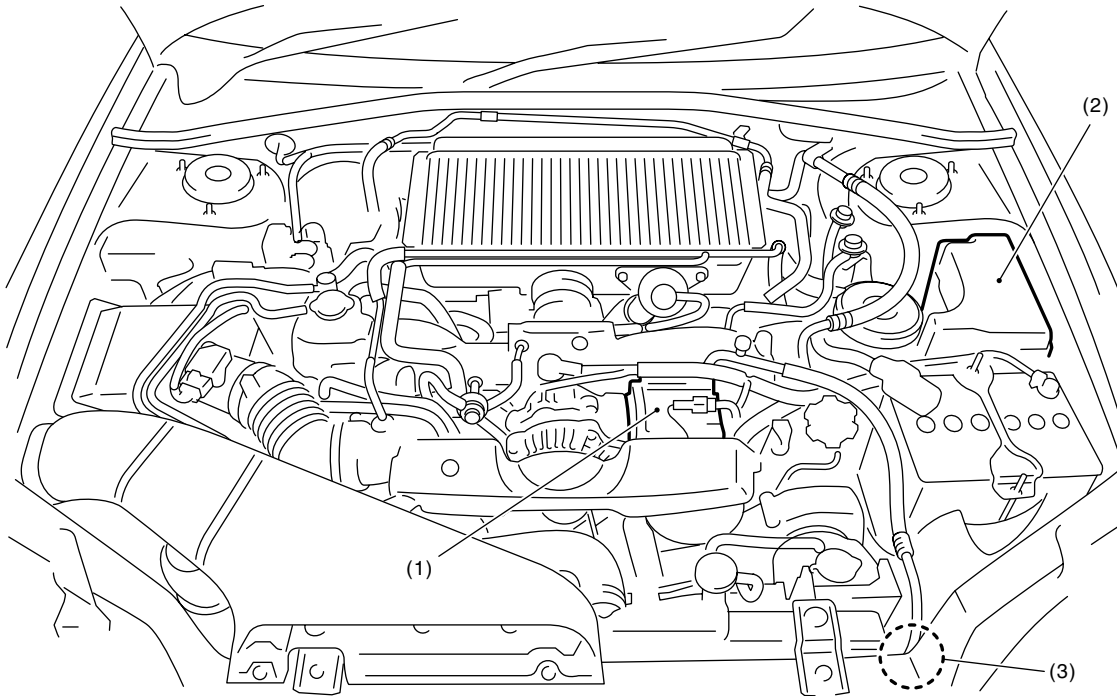

AC-01393

(1) A/C compressor
(2) A/C relay

(3) Pressure switch

(4) Ambient sensor

Electrical Component Location

HVAC SYSTEM (AUTO A/C) (DIAGNOSTICS)

2. PASSENGER COMPARTMENT

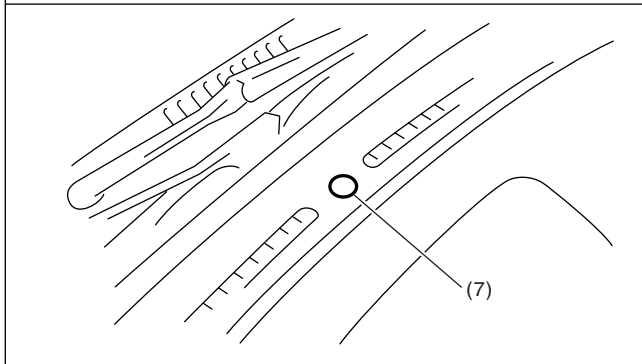
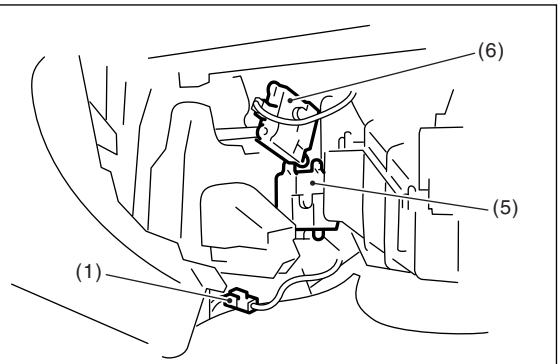
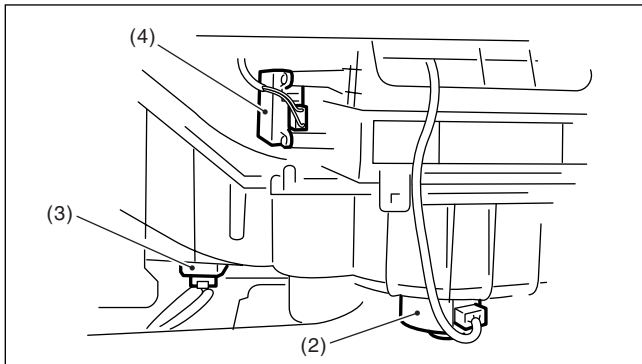
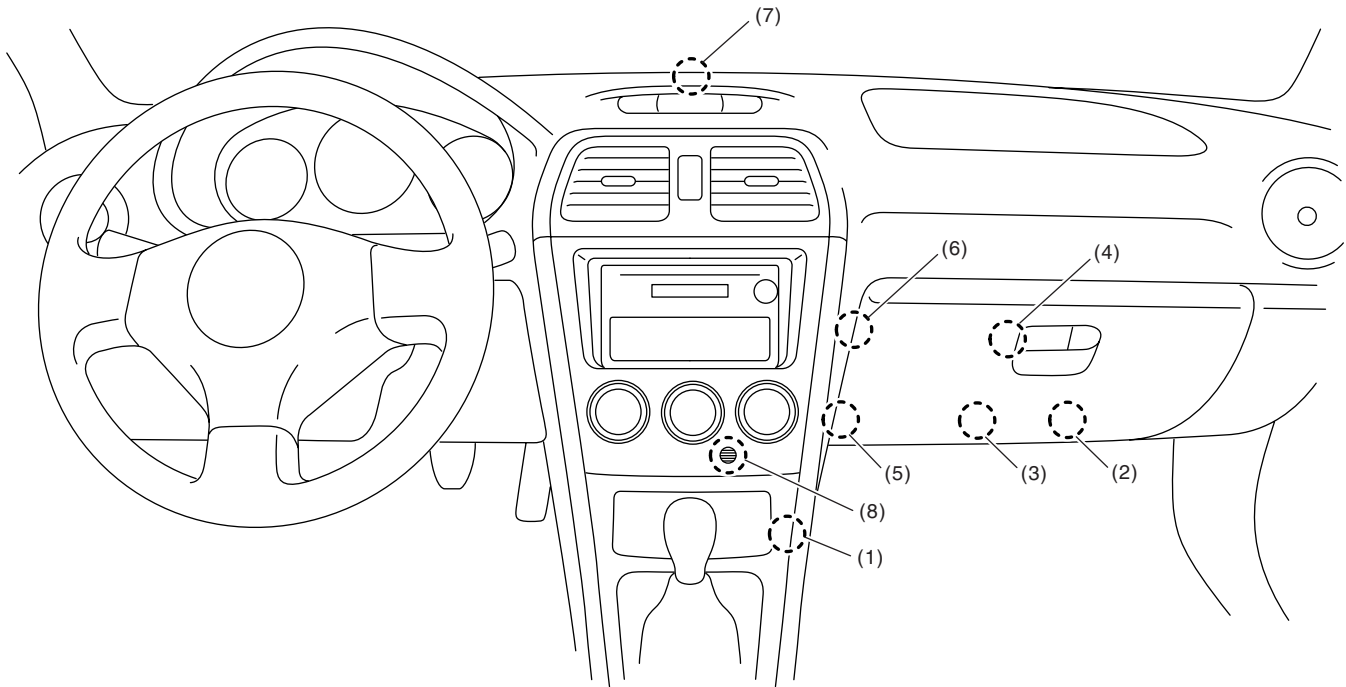

AC-01127

- | | | |
|---------------------------|---------------------------|---|
| (1) Evaporator sensor | (4) Intake door actuator | (7) Sunload sensor |
| (2) Blower motor | (5) Air mix door actuator | (8) In-vehicle sensor (built-in with Auto A/C control module) |
| (3) Blower motor resistor | (6) Mode door actuator | |

Auto A/C Control Module I/O Signal

HVAC SYSTEM (AUTO A/C) (DIAGNOSTICS)

4. Auto A/C Control Module I/O Signal

A: ELECTRICAL SPECIFICATION

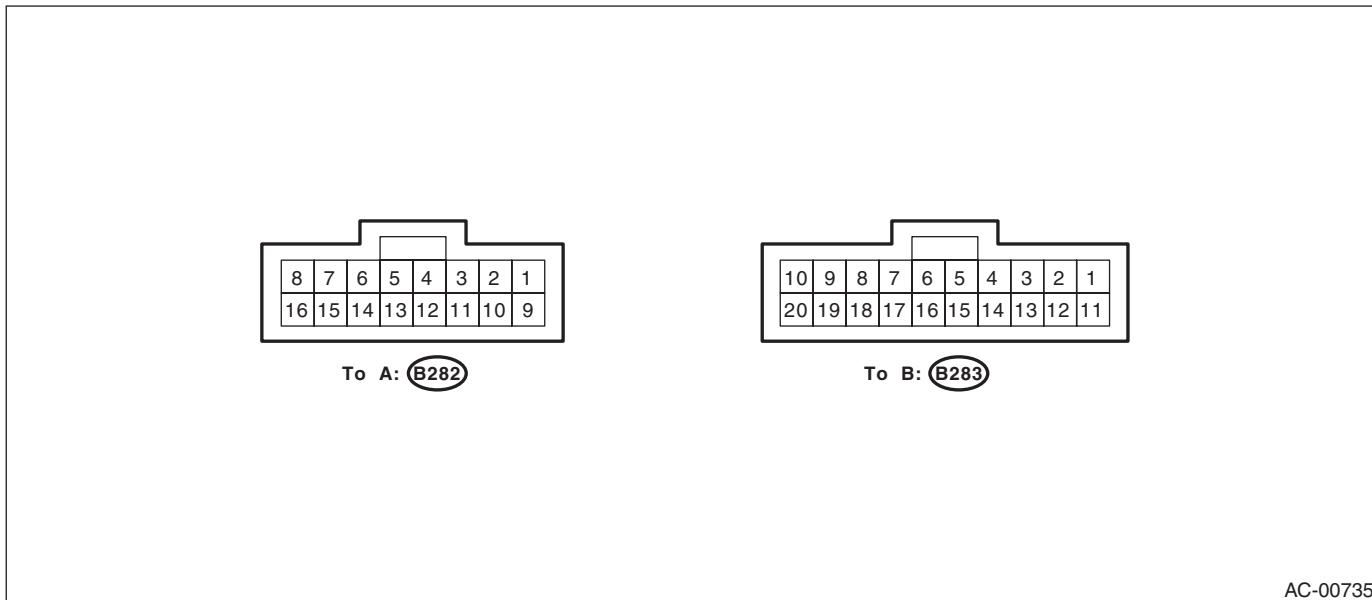

AC-00735

Content	Connector & Terminal No.	Signal (V)
Battery power supply (Memory back-up)	B1 — B12	Battery voltage, 13 — 14 (engine running)
IGN power supply	A8 — B12	Battery voltage (ignition switch ON), 13 — 14 (engine running)
ACC power supply	B2 — B12	Battery voltage, 0 (engine cranking), Battery voltage (engine running)
Auto A/C control module ground circuit	B12 — chassis ground	0 (ignition switch ON) — circuit constantly grounded to chassis
Sensor ground circuit	B17 — chassis ground	0 (ignition switch ON) — circuit constantly grounded to chassis
Ambient sensor	B9 — B17	Approx. 5 (disconnect connector, and ignition switch ON)
Evaporator sensor	B7 — B17	
Thermometer	B15 — B12	
Sunload sensor	B16 — B17	Approx. 5 (disconnect connector, and ignition switch ON)
Air mix door actuator	B5 — B1	Battery voltage (ignition switch ON)
Air mix door actuator P.B.R.	A4 — B17	LAN connection
Mode door actuator	B6 — B17	Battery voltage (ignition switch ON)
Mode door actuator P.B.R.	A12 — B17	LAN connection
Intake door FRS voltage	A15 — A7	Battery voltage (FRESH/RECIRC switch OFF)
Intake door CIRC voltage	A7 — A15	Battery voltage (FRESH/RECIRC switch ON)
Blower fan relay	B14 — body	Battery voltage (ignition switch ON)
A/C relay	B3 — B12	0 (ignition and A/C switches ON) Battery voltage (A/C switch OFF)
Illumination control signal	B10 — B20	Battery voltage (ignition and lighting switches ON)
Rear window defogger	A 13 — B12	0 (ignition switch ON, rear window defogger switch ON)

B: WIRING DIAGRAM

1. AIR CONDITIONER AUTO A/C MODEL

<Ref. to WI-92, AUTO A/C MODEL, WIRING DIAGRAM, Air Conditioning System.>

Diagnostic Chart for Self-Diagnosis

HVAC SYSTEM (AUTO A/C) (DIAGNOSTICS)

5. Diagnostic Chart for Self-Diagnosis

A: OPERATION

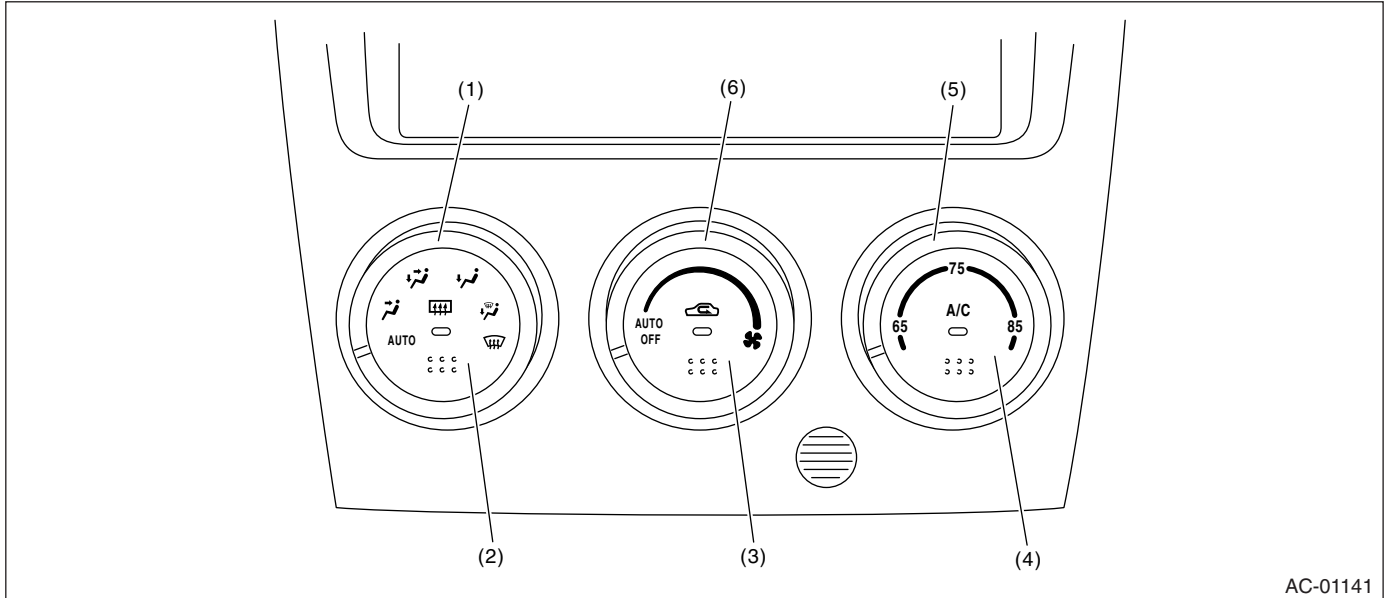

AC-01141

- | | | |
|---------------------------------|-------------------------|------------------------------|
| (1) Air flow control dial | (3) FRESH/RECIRC switch | (5) Temperature control dial |
| (2) Rear window defogger switch | (4) A/C switch | (6) Fan speed control dial |

Step	Check	Yes	No
1 SELECT CONTROL PANEL TO SELF-DIAGNOSIS MODE. 1) Turn the fan speed control dial to OFF position. 2) Start the engine and press the A/C switch for at least 5 seconds. The A/C switch must be pressed within 10 seconds after starting engine.	Does the self-diagnosis mode operate?	Go to step 2.	<Ref. to AC(diag)-11, A/C OR SELF-DIAGNOSIS SYSTEMS DO NOT OPERATE, Diagnostics for A/C System Malfunction.>
2 CHECK LED ILLUMINATION. Make sure that all switch LED illuminate on control panel.	Do all LED illuminate?	Go to step 3.	Check the switch LED.
3 CHECK SENSORS MALFUNCTION. 1) Turn the fan speed control dial to AUTO position. 2) If the system has trouble for each sensor, rear window defogger switch LED is turned off. 3) If the system has no trouble, rear window defogger switch LED is illuminated.	Does the rear window defogger switch LED illuminate?	Go to step 5.	Go to step 4.
4 CONFIRM MALFUNCTIONING SENSOR. 1) Turn the fan speed control dial to 1 — 6th position. 2) Turn the air flow control dial to each mode position, check each switch LED illumination according to sensor check table. <Ref. to AC(diag)-10, SENSOR CHECK TABLE, OPERATION, Diagnostic Chart for Self-Diagnosis.>	Do FRESH/RECIRC and A/C switch LED illuminate when turning the dial to each mode position?	Go to step 5.	Repair the malfunctioning sensor. <Ref. to AC(diag)-24, Diagnostic Procedure for Sensors.>

Diagnostic Chart for Self-Diagnosis

HVAC SYSTEM (AUTO A/C) (DIAGNOSTICS)

Step	Check	Yes	No
5 CHECK MODE DOOR POSITION SIGNAL. 1) Turn the fan speed control dial to 7 — 12th position. 2) If the system has trouble for mode door position signal, rear window defogger switch LED is turned off. 3) If the system has no trouble, rear window defogger switch LED is illuminated.	Does the rear window defogger switch LED illuminate?	Go to step 6.	Check the mode door actuator circuit. <Ref. to AC(diag)-20, MODE DOOR ACTUATOR, Diagnostic Procedure for Actuators.>
6 CHECK BLOWER FAN OPERATION. 1) Turn the fan speed control dial to 13 — 18th position. 2) Turn the temperature control dial, check that blower fan speed changes depending on set temperature.	Does the blower fan speed change?	Go to step 7.	Check the blower motor circuit. <Ref. to AC(diag)-13, BLOWER FAN DOES NOT ROTATE., Diagnostics for A/C System Malfunction.>
7 CHECK OPERATION OF EACH ACTUATOR, BLOWER FAN AND COMPRESSOR CLUTCH. 1) Turn the fan speed control dial to 19 — 25th position. 2) Select the operating mode by turning air flow control dial. 3) Check the operation of each mode according to operating mode table. <Ref. to AC(diag)-10, OPERATING MODE TABLE, OPERATION, Diagnostic Chart for Self-Diagnosis.> <ul style="list-style-type: none"> • Air inlet: • Air outlet: • Air mix door: • Blower fan: • A/C compressor: 	Does the operation of each mode match to operating mode table?	Push the A/C switch or turn the ignition switch to OFF, and finish the self-diagnosis.	Repair the malfunction part according to each diagnostics chart.

Diagnostic Chart for Self-Diagnosis

HVAC SYSTEM (AUTO A/C) (DIAGNOSTICS)

1. SENSOR CHECK TABLE

NOTE:

When the sunload sensor is checked indoors or in the shade, open circuit might be indicated. Always check the sunload sensor at a place where sun shines directly on it.

Air flow control dial position	Checked sensor	No trouble	Short circuit	Open circuit
VENT	Ambient sensor	A/C switch LED and FRESH/RECIRC switch LED illuminate	A/C switch LED illuminate	FRESH/RECIRC switch LED illuminate
BI-LEVEL	In-vehicle sensor	A/C switch LED and FRESH/RECIRC switch LED illuminate	A/C switch LED illuminate	FRESH/RECIRC switch LED illuminate
HEAT	Evaporator sensor	A/C switch LED and FRESH/RECIRC switch LED illuminate	A/C switch LED illuminate	FRESH/RECIRC switch LED illuminate
DEF/HEAT	Sunload sensor	A/C switch LED and FRESH/RECIRC switch LED illuminate	A/C switch LED illuminate	FRESH/RECIRC switch LED illuminate
DEF	Air mix door motor (Potential balance resistor)	A/C switch LED and FRESH/RECIRC switch LED illuminate	A/C switch LED illuminate	

2. OPERATING MODE TABLE

Operation	Air flow control dial position				
	VENT	BI-LEVEL	HEAT	DEF/HEAT	DEF
Air outlet	VENT	BI-LEVEL	HEAT	DEF/HEAT	DEF
Air inlet	RECIRC	RECIRC	RECIRC	FRESH	FRESH
Air mix door	FULL COOL	FULL COOL	FULL HOT	FULL HOT	FULL COOL
Blower fan	5V	5V	8V	10V	Power supply voltage
A/C compressor	ON	OFF	OFF	ON	ON

Diagnostics for A/C System Malfunction

HVAC SYSTEM (AUTO A/C) (DIAGNOSTICS)

6. Diagnostics for A/C System Malfunction

A: A/C OR SELF-DIAGNOSIS SYSTEMS DO NOT OPERATE

TROUBLE SYMPTOM:

- Switch LEDs are faulty or switches do not operate.
- Self-diagnosis system does not operate.

WIRING DIAGRAM:

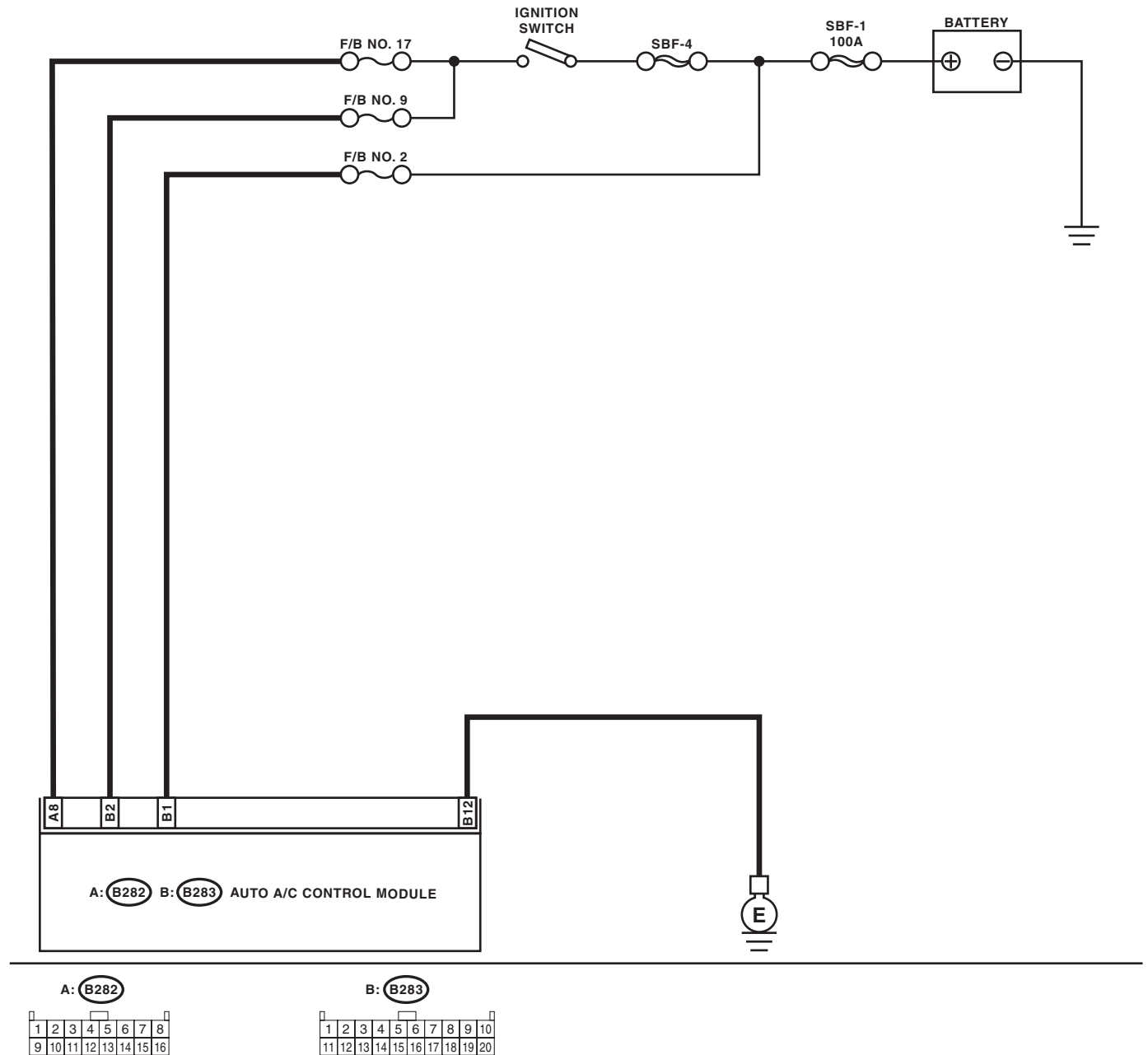

AC-01142

Diagnostics for A/C System Malfunction

HVAC SYSTEM (AUTO A/C) (DIAGNOSTICS)

Step	Check	Yes	No
1 CHECK FUSE. 1) Turn the ignition switch to OFF. 2) Remove the fuse No. 2 from main fuse box. 3) Check the condition of fuse.	Is the fuse blown-out?	Replace the fuse.	Go to step 2.
2 CHECK FUSE. 1) Turn the ignition switch to OFF. 2) Remove the fuses No. 9 and No. 17 from fuse & relay box. 3) Check the condition of fuse.	Is the fuse blown-out?	Replace the fuse.	Go to step 3.
3 CHECK AUTO A/C CONTROL MODULE POWER CIRCUIT. 1) Pull out the auto A/C control module connector. 2) Measure the voltage between auto A/C control module connector terminal and chassis ground when turning ignition switch to OFF. <i>Connector & terminal</i> <i>(B283) No. 1 (+) — Chassis ground (-):</i>	Is the voltage more than 10 V?	Go to step 4.	Repair the short circuit in harness for power supply line.
4 CHECK AUTO A/C CONTROL MODULE POWER CIRCUIT. Measure the voltage between auto A/C control module connector terminal and chassis ground when turning the ignition switch to ACC. <i>Connector & terminal</i> <i>(B283) No. 2 (+) — Chassis ground (-):</i>	Is the voltage more than 10 V?	Go to step 5.	Repair the short circuit in harness for power supply line.
5 CHECK AUTO A/C CONTROL MODULE POWER CIRCUIT. Measure the voltage between auto A/C control module connector terminal and chassis ground when turning the ignition switch to ON. <i>Connector & terminal</i> <i>(B282) No. 8 (+) — Chassis ground (-):</i>	Is the voltage more than 10 V?	Go to step 6.	Repair the short circuit in harness for power supply line.
6 CHECK AUTO A/C CONTROL MODULE GROUND CIRCUIT. Measure the resistance of harness between auto A/C control module and chassis ground. <i>Connector & terminal</i> <i>(B283) No. 12 — Chassis ground:</i>	Is the resistance less than 5 Ω ?	Go to step 7.	Repair the harness for ground line.
7 CHECK POOR CONTACT. Check poor contact in auto A/C control module connector.	Is there poor contact in connector?	Repair the connector.	Replace the auto A/C control module.

Diagnostics for A/C System Malfunction

HVAC SYSTEM (AUTO A/C) (DIAGNOSTICS)

B: BLOWER FAN DOES NOT ROTATE.

TROUBLE SYMPTOM:

- Blower motor is not rotated.
- Blower motor is not rotated at "HI".

WIRING DIAGRAM:

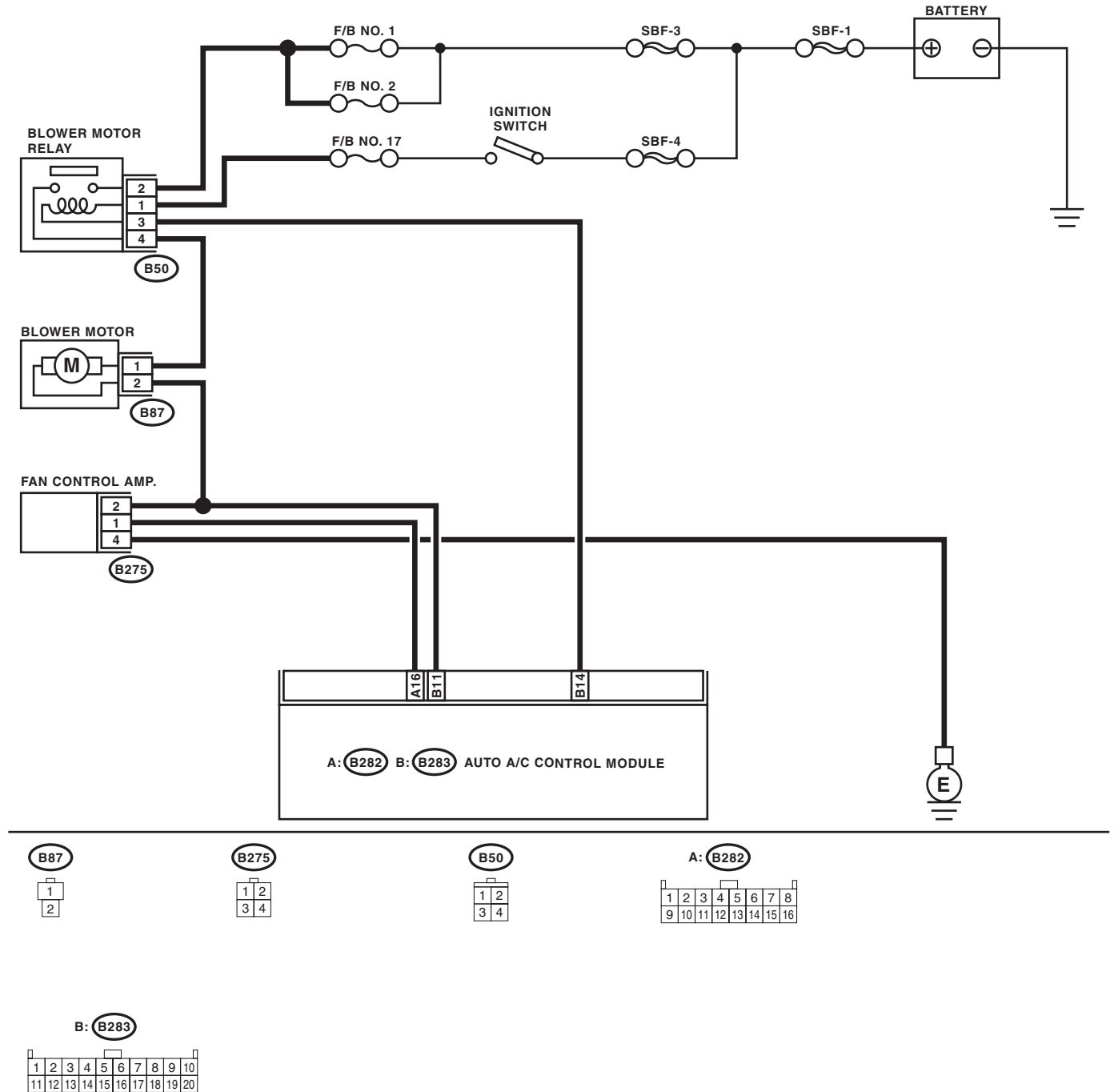

AC-01143

Diagnostics for A/C System Malfunction

HVAC SYSTEM (AUTO A/C) (DIAGNOSTICS)

Step	Check	Yes	No
1 CHECK FUSE. 1) Remove the No. 1, No. 2 and No. 17 fuses in fuse & relay box. 2) Check the condition of fuses.	Are any of the fuses blown-out?	Replace the fuse.	Go to step 2.
2 CHECK POWER SUPPLY TO BLOWER FAN MOTOR. 1) Turn the ignition switch to ON. 2) Turn the fan speed control dial to the right. 3) Measure the voltage between blower fan motor and chassis ground. Connector & terminal (B87) No. 1 (+) — Chassis ground (-):	Is the voltage more than 10 V?	Go to step 3.	Repair the open circuit in harness for blower fan motor power supply line.
3 CHECK BLOWER FAN MOTOR RELAY. 1) Turn the ignition switch to OFF. 2) Remove the blower fan motor relay. 3) Connect the battery positive (+) terminal to No. 1 terminal and negative (-) terminal to No. 3 terminal of blower fan motor connector. 4) Measure the resistance between No. 2 and No. 4 terminals. Terminals No. 2 — No. 4:	Is the resistance less than 1 Ω ?	Go to step 4.	Replace the blower fan motor relay.
4 CHECK BLOWER FAN MOTOR. 1) Disconnect the connector from blower fan motor. 2) Connect the battery positive (+) terminal to No. 1 terminal and negative (-) terminal to No. 2 terminal of blower fan motor connector. 3) Make sure that the blower fan motor is operated.	Does the blower fan motor operate?	Go to step 5.	Replace the blower fan motor.
5 CHECK POOR CONTACT. Check poor contact in auto A/C control module connector.	Is there poor contact in connector?	Repair the connector.	Replace the auto A/C control module.

Diagnostics for A/C System Malfunction

HVAC SYSTEM (AUTO A/C) (DIAGNOSTICS)

C: COMPARTMENT TEMPERATURE DOES NOT CHANGE, OR A/C SYSTEM DOES NOT RESPOND PROMPTLY.

TROUBLE SYMPTOM:

- Compartment temperature is not changed. (No cool air is discharged.)
- A/C system does not respond quickly.

WIRING DIAGRAM:

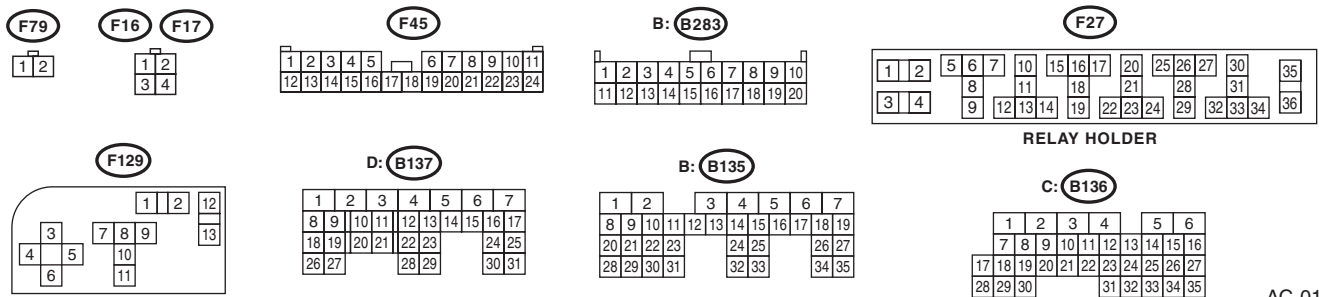
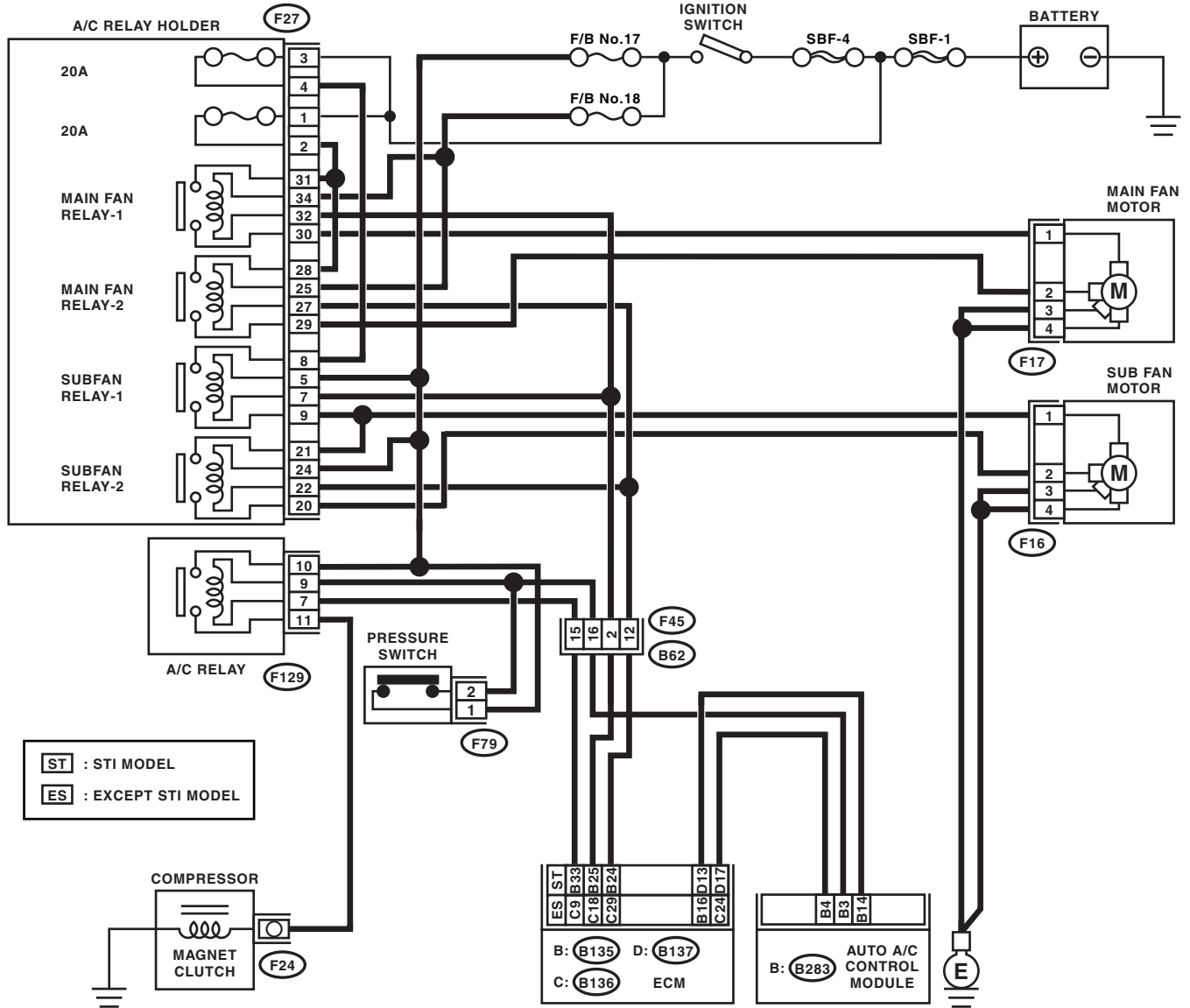

AC-01395

Diagnostics for A/C System Malfunction

HVAC SYSTEM (AUTO A/C) (DIAGNOSTICS)

Step	Check	Yes	No
1 CHECK FUSE. 1) Turn the ignition switch to OFF. 2) Remove the No. 2 fuse in main fuse box. 3) Check the condition of fuse.	Is the fuse blown-out?	Replace the fuse.	Go to step 2.
2 CHECK POWER SUPPLY TO MAGNET CLUTCH OF A/C COMPRESSOR. 1) Start the engine, and turn A/C switch to ON. 2) Set the temperature control dial to maximum cold position. 3) Measure the voltage between magnet clutch connector and chassis ground. Connector & terminal (F24) No. 1 (+) — Chassis ground (-):	Is the voltage more than 10 V?	Go to step 3.	Repair the open circuit in harness for power supply line of the A/C compressor.
3 CHECK SIGNAL VOLTAGE TO A/C RELAY. 1) Turn the ignition switch to ON. 2) Turn the A/C switch to ON. 3) Measure the signal voltage between A/C relay and chassis ground. Connector & terminal (F129) No. 7 (+) — Chassis ground (-):	Is the voltage more than 10 V?	Go to step 4.	Repair the open circuit in harness for A/C relay signal circuit.
4 CHECK A/C RELAY. Check the A/C relay. <Ref. to AC-37, INSPECTION, Relay and Fuse.>	Is the operation of the relay OK?	Go to step 5.	Replace the A/C relay.
5 CHECK OPERATION OF MAIN FAN MOTOR. 1) Start the engine. 2) Turn the A/C switch to ON. 3) Check the operation of main fan motor.	Does the radiator main fan operate?	Go to step 10.	Go to step 6.
6 CHECK POWER SUPPLY TO MAIN FAN MOTOR. CAUTION: Be careful not to overheat the engine during repair. 1) Turn the ignition switch to OFF. 2) Disconnect the connector from main fan motor. 3) Start the engine, and warm it up until engine coolant temperature increases over 95°C (203°F). 4) Stop the engine and turn ignition switch to ON. 5) Measure the voltage between main fan motor connector and chassis ground. Connector & terminal (F17) No. 1, 2 (+) — Chassis ground (-):	Is the voltage more than 10 V?	Go to step 7.	Repair the open circuit in harness for power supply circuit.
7 CHECK GROUND CIRCUIT OF MAIN FAN MOTOR. 1) Turn the ignition switch to OFF. 2) Measure the resistance between main fan motor connector and chassis ground. Connector & terminal (F17) No. 3, 4 — Chassis ground:	Is the resistance less than 1 Ω?	Go to step 8.	Repair the open circuit in harness between main fan motor connector and chassis ground.
8 CHECK POOR CONTACT. Check poor contact in main fan motor connector.	Is there poor contact in main fan motor connector?	Repair the poor contact in main fan motor connector.	Go to step 9.
9 CHECK MAIN FAN MOTOR. Connect the battery positive (+) terminal to terminal No. 1 and 2, and negative (-) terminal to terminal No. 3 and 4.	Does the main fan rotate?	Repair the poor contact in main fan motor connector.	Replace the main fan motor with a new one.

Diagnostics for A/C System Malfunction

HVAC SYSTEM (AUTO A/C) (DIAGNOSTICS)

Step	Check	Yes	No	
10	CHECK OPERATION OF SUB FAN MOTOR. Check the operation of sub fan motor.	Does the radiator sub fan operate?	Go to step 15.	Go to step 11.
11	CHECK POWER SUPPLY TO SUB FAN MOTOR. CAUTION: Be careful not to overheat the engine during repair. 1) Turn the ignition switch to OFF. 2) Disconnect the connector from sub fan motor. 3) Start the engine, and warm it up until engine coolant temperature increases over 100°C (212°F). 4) Stop the engine and turn the ignition switch to ON. 5) Measure the voltage between sub fan motor connector and chassis ground. Connector & terminal (F16) No. 1, 2 (+) — Chassis ground (-):	Is the voltage more than 10 V?	Go to step 12.	Repair the open circuit in harness for power supply circuit.
12	CHECK GROUND CIRCUIT OF SUB FAN MOTOR. 1) Turn the ignition switch to OFF. 2) Measure the resistance between sub fan motor connector and chassis ground. Connector & terminal (F16) No. 3, 4 — Chassis ground:	Is the resistance less than 1 Ω?	Go to step 13.	Repair the open circuit in harness between sub fan motor connector and chassis ground.
13	CHECK POOR CONTACT. Check poor contact in sub fan motor connector.	Is there poor contact in sub fan motor connector?	Repair the poor contact in sub fan motor connector.	Go to step 14.
14	CHECK SUB FAN MOTOR. Connect the battery positive (+) terminal to terminal No. 1 and 2, and negative (-) terminal to terminal No. 3 and 4.	Does the sub fan rotate?	Repair the poor contact in sub fan motor connector.	Replace the sub fan motor with a new one.
15	CHECK EACH SENSOR AND POTENTIOMETER. Check the sensors and potentiometer for proper operation using the self-diagnostic function. <Ref. to AC(diag)-8, Diagnostic Chart for Self-Diagnosis.>	Is the operation of each sensor and potentiometer normal?	Go to step 16.	Check the sensor and circuit. <Ref. to AC(diag)-24, Diagnostic Procedure for Sensors.>
16	CHECK CONNECTION OF ASPIRATOR HOSE. Make sure the connection of aspirator hose is correct.	Is the connection of aspirator hose correct?	Go to step 17.	Repair the aspirator hose connection.
17	CHECK EACH ACTUATOR. Check the actuators for proper operation using the self-diagnostic function. <Ref. to AC(diag)-8, Diagnostic Chart for Self-Diagnosis.>	Is the operation of each actuator normal?	Go to step 18.	Check the actuator and circuit. <Ref. to AC(diag)-18, Diagnostic Procedure for Actuators.>
18	CHECK POOR CONTACT. Check poor contact in auto A/C control module connector.	Is there poor contact in connector?	Repair the connector.	Replace the auto A/C control module.

Diagnostic Procedure for Actuators

HVAC SYSTEM (AUTO A/C) (DIAGNOSTICS)

7. Diagnostic Procedure for Actuators

A: INTAKE DOOR ACTUATOR

TROUBLE SYMPTOM:

FRESH/RECIRC mode is not changed.

WIRING DIAGRAM:

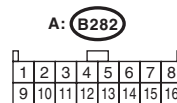
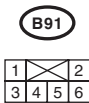
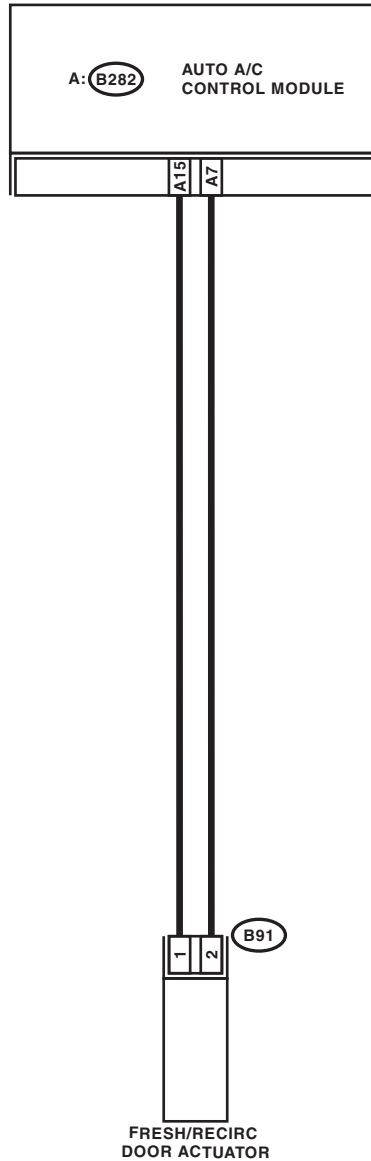

AC-01424

Diagnostic Procedure for Actuators

HVAC SYSTEM (AUTO A/C) (DIAGNOSTICS)

Step	Check	Yes	No
1 CHECK FUSE. 1) Remove the No. 17 fuse in fuse & relay box. 2) Check the condition of fuse.	Is the fuse blown-out?	Replace the fuse.	Go to step 2.
2 CHECK SIGNAL VOLTAGE. 1) Change the air intake to RECIRC by pushing FRESH/RECIRC switch. 2) Measure the voltage between auto A/C control module and chassis ground. <i>Connector & terminal</i> <i>(B282) No. 15 (+) — Chassis ground (-):</i>	Is the voltage less than 1 V?	Go to step 3.	Repair the short circuit in harness for power supply line.
3 CHECK SIGNAL VOLTAGE. 1) Change the air intake to FRESH with pushing FRESH/RECIRC switch. 2) Measure the voltage between auto A/C control module and chassis ground. <i>Connector & terminal</i> <i>(B282) No. 7 (+) — Chassis ground (-):</i>	Is the voltage less than 1 V?	Go to step 4.	Repair the short circuit in harness for power supply line.
4 CHECK HARNESS CONNECTOR BETWEEN AUTO A/C CONTROL MODULE AND FRESH/RECIRC ACTUATOR. 1) Turn the ignition switch to OFF. 2) Disconnect the connector from auto A/C control module and intake door actuator. 3) Measure the resistance of harness between auto A/C control module and intake door actuator. <i>Connector & terminal</i> <i>(B282) No. 15 — (B91) No. 1:</i>	Is the resistance less than 1 Ω ?	Go to step 5.	Repair the open circuit in harness between auto A/C control module and intake door actuator.
5 CHECK HARNESS CONNECTOR BETWEEN AUTO A/C CONTROL MODULE AND FRESH/RECIRC ACTUATOR. Measure the resistance of harness between auto A/C control module and intake door actuator. <i>Connector & terminal</i> <i>(B282) No. 7 — (B91) No. 2:</i>	Is the resistance less than 1 Ω ?	Go to step 6.	Repair the open circuit in harness between auto A/C control module and intake door actuator.
6 CHECK POOR CONTACT. Check poor contact in auto A/C control module connector.	Is there poor contact in connector?	Repair the connector.	Replace the auto A/C control module.

Diagnostic Procedure for Actuators

HVAC SYSTEM (AUTO A/C) (DIAGNOSTICS)

B: MODE DOOR ACTUATOR

TROUBLE SYMPTOM:

Air flow outlet is not changed.

WIRING DIAGRAM:

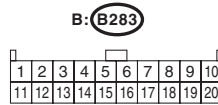
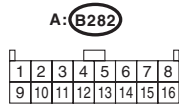
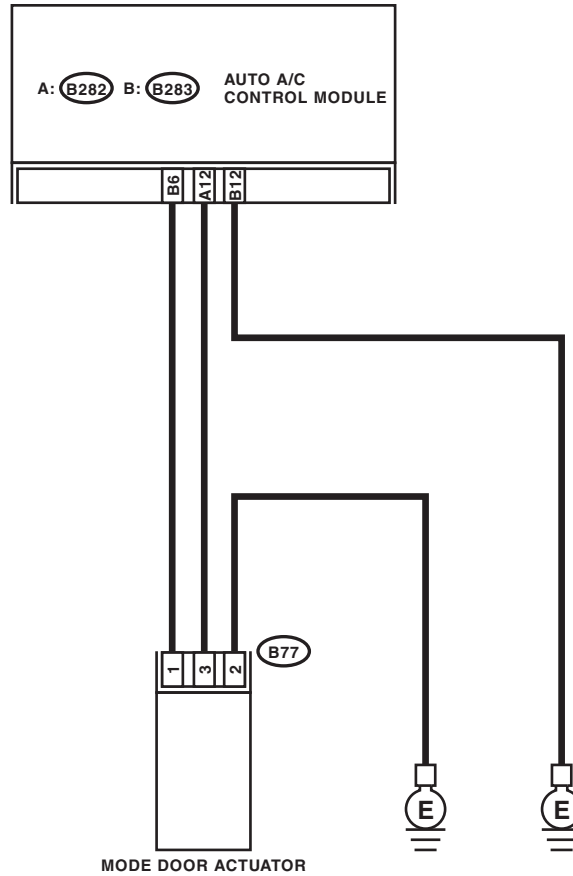

Diagnostic Procedure for Actuators

HVAC SYSTEM (AUTO A/C) (DIAGNOSTICS)

Step	Check	Yes	No
1 CHECK POWER SUPPLY FOR AUTO A/C CONTROL MODULE SIDE. 1) Turn the ignition switch to ON. 2) Turn the A/C switch to ON. 3) Measure the voltage between auto A/C control module harness connector terminal and chassis ground. <i>Connector & terminal</i> <i>(B283) No. 6 (+) — Chassis ground (-):</i>	Is the voltage more than 10 V?	Go to step 2.	Replace the auto A/C control module.
2 CHECK POWER SUPPLY FOR ACTUATOR SIDE. Measure the voltage between mode door actuator harness connector terminal and chassis ground. <i>Connector & terminal</i> <i>(B77) No. 1 (+) — Chassis ground (-):</i>	Is the voltage more than 10 V?	Go to step 3.	Repair the open circuit in harness between auto A/C control module and mode door actuator.
3 CHECK SIGNAL FOR AUTO A/C CONTROL MODULE SIDE. Measure the voltage between auto A/C control module harness connector terminal and chassis ground with oscilloscope. <i>Connector & terminal</i> <i>(B282) No. 12 (+) — Chassis ground (-):</i>	Is the voltage approx. 5.5 V?	Go to step 4.	Replace the auto A/C control module.
4 CHECK SIGNAL FOR ACTUATOR SIDE. Measure the voltage between mode door actuator harness connector terminal and chassis ground. <i>Connector & terminal</i> <i>(B77) No. 3 (+) — Chassis ground (-):</i>	Is the voltage approx. 5.5 V?	Go to step 5.	Repair the open circuit in harness between auto A/C control module and mode door actuator.
5 CHECK GROUND CIRCUIT OF ACTUATOR. 1) Turn the ignition switch and A/C switch to OFF. 2) Measure the resistance between mode door actuator harness connector terminal and chassis ground. <i>Connector & terminal</i> <i>(B77) No. 2 — Chassis ground:</i>	Is the resistance less than 1 Ω ?	Go to step 6.	Repair the open circuit in harness between mode door actuator and chassis ground.
6 CHECK POOR CONTACT. Check poor contact in auto A/C control module connector.	Is there poor contact in connector?	Repair the connector.	Replace the auto A/C control module.

Diagnostic Procedure for Actuators

HVAC SYSTEM (AUTO A/C) (DIAGNOSTICS)

C: AIR MIX DOOR ACTUATOR

TROUBLE SYMPTOM:

Outlet air temperature is not changed.

WIRING DIAGRAM:

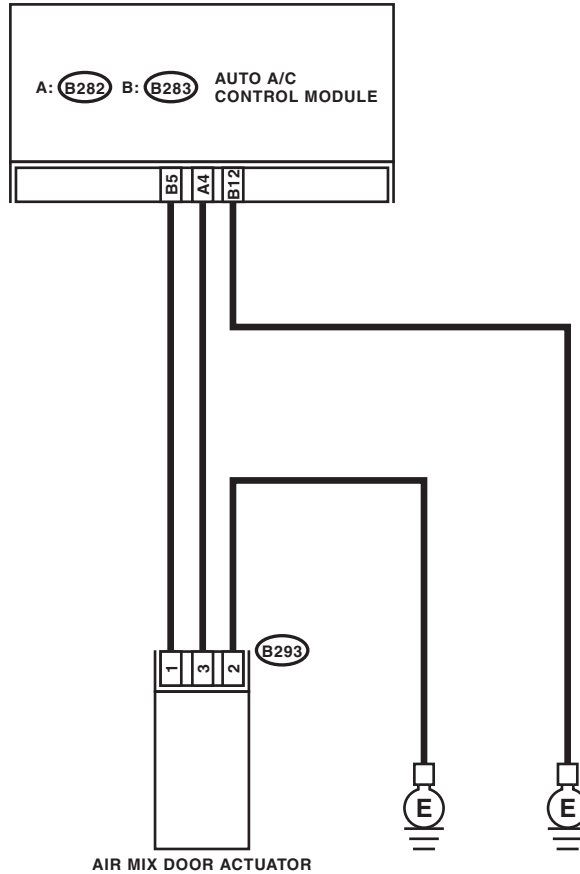

(B293)



A: (B282)

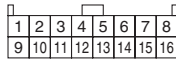

B: (B283)

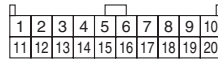

AC-01147

Diagnostic Procedure for Actuators

HVAC SYSTEM (AUTO A/C) (DIAGNOSTICS)

Step	Check	Yes	No
1 CHECK POWER SUPPLY FOR AUTO A/C CONTROL MODULE SIDE. 1) Turn the ignition switch to ON. 2) Turn the A/C switch to ON. 3) Measure the voltage between auto A/C control module harness connector terminal and chassis ground. <i>Connector & terminal</i> <i>(B283) No. 5 (+) — Chassis ground (-):</i>	Is the voltage more than 10 V?	Go to step 2.	Replace the auto A/C control module.
2 CHECK POWER SUPPLY FOR ACTUATOR SIDE. Measure the voltage between air mix door actuator harness connector terminal and chassis ground. <i>Connector & terminal</i> <i>(B293) No. 1 (+) — Chassis ground (-):</i>	Is the voltage more than 10 V?	Go to step 3.	Repair the open circuit in harness between auto A/C control module and air mix door actuator.
3 CHECK SIGNAL FOR AUTO A/C CONTROL MODULE SIDE. Measure the voltage between auto A/C control module harness connector terminal and chassis ground with oscilloscope. <i>Connector & terminal</i> <i>(B282) No. 4 (+) — Chassis ground (-):</i>	Is the voltage approx. 5.5 V?	Go to step 4.	Replace the auto A/C control module.
4 CHECK SIGNAL FOR ACTUATOR SIDE. Measure the voltage between air mix door actuator harness connector terminal and chassis ground with oscilloscope. <i>Connector & terminal</i> <i>(B293) No. 3 (+) — Chassis ground (-):</i>	Is the voltage approx. 5.5 V?	Go to step 5.	Repair the open circuit in harness between auto A/C control module and air mix door actuator.
5 CHECK GROUND CIRCUIT OF ACTUATOR. 1) Turn the ignition switch and A/C switch to OFF. 2) Measure the resistance between air mix door actuator harness connector terminal and chassis ground. <i>Connector & terminal</i> <i>(B293) No. 2 — Chassis ground:</i>	Is the resistance less than 1 Ω ?	Go to step 6.	Repair the open circuit in harness between air mix door actuator and chassis ground.
6 CHECK POOR CONTACT. Check poor contact in auto A/C control module connector.	Is there poor contact in connector?	Repair the connector.	Replace the auto A/C control module.

Diagnostic Procedure for Sensors

HVAC SYSTEM (AUTO A/C) (DIAGNOSTICS)

8. Diagnostic Procedure for Sensors

A: AMBIENT SENSOR

TROUBLE SYMPTOM:

Fan speed is not switched when the fan speed control dial is in AUTO position.

WIRING DIAGRAM:

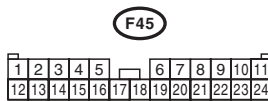
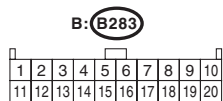
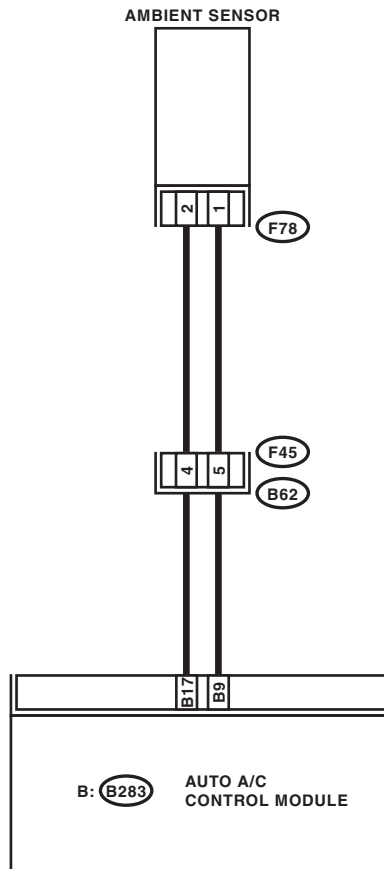

Diagnostic Procedure for Sensors

HVAC SYSTEM (AUTO A/C) (DIAGNOSTICS)

Step	Check	Yes	No
1 CHECK AMBIENT SENSOR. 1) Turn the ignition switch to OFF. 2) Disconnect the connector from ambient sensor. 3) Measure the resistance between connector terminals of ambient sensor. <i>Terminals</i> <i>No. 1 — No. 2:</i>	Is the resistance approx. 2.2 k Ω at 25°C (77°F)?	Go to step 2.	Replace the ambient sensor.
2 CHECK INPUT SIGNALS FOR AMBIENT SENSOR. 1) Turn the ignition ON. 2) Measure the voltage between (F78) connector terminals. <i>Connector & terminal</i> <i>(F78) No. 1 (+) — No. 2 (-):</i>	Is the voltage approx. 5 V?	Go to step 6.	Go to step 3.
3 CHECK OUTPUT SIGNALS FROM AUTO A/C CONTROL MODULE. 1) Turn the ignition switch to OFF. 2) Pull out the auto A/C control module. 3) Disconnect the connector from ambient sensor. 4) Turn the ignition switch to ON. 5) Measure the voltage between connector terminals of auto A/C control module. <i>Connector & terminal</i> <i>(B283) No. 9 (+) — No. 17 (-):</i>	Is the voltage approx. 5 V?	Go to step 4.	Go to step 6.
4 CHECK HARNESS CONNECTOR BETWEEN AUTO A/C CONTROL MODULE AND AMBIENT SENSOR. 1) Turn the ignition switch to OFF. 2) Disconnect the connectors from auto A/C control module. 3) Measure the resistance of harness between auto A/C control module and ambient sensor. <i>Connector & terminal</i> <i>(F78) No. 1 — (B283) No. 9:</i>	Is the resistance less than 1 Ω ?	Go to step 5.	Repair the open circuit in harness between auto A/C control module and ambient sensor.
5 CHECK HARNESS CONNECTOR BETWEEN AUTO A/C CONTROL MODULE AND AMBIENT SENSOR. Measure the resistance of harness between auto A/C control module and ambient sensor. <i>Connector & terminal</i> <i>(F78) No. 2 — (B283) No. 17:</i>	Is the resistance less than 1 Ω ?	Go to step 6.	Repair the open circuit in harness between auto A/C control module and ambient sensor.
6 CHECK POOR CONTACT. Check poor contact in auto A/C control module connector.	Is there poor contact in connector?	Repair the connector.	Replace the auto A/C control module.

B: IN-VEHICLE SENSOR

TROUBLE SYMPTOM:

- When turning the AUTO switch to ON, blower fan speed, outlet port and inlet port is not changed.
- If the switch LED indicates that the sensor is malfunctioning, replace the auto A/C control module. The in-vehicle sensor is built into the auto A/C control module and cannot be replaced as a single unit.

Diagnostic Procedure for Sensors

HVAC SYSTEM (AUTO A/C) (DIAGNOSTICS)

C: EVAPORATOR SENSOR

WIRING DIAGRAM:

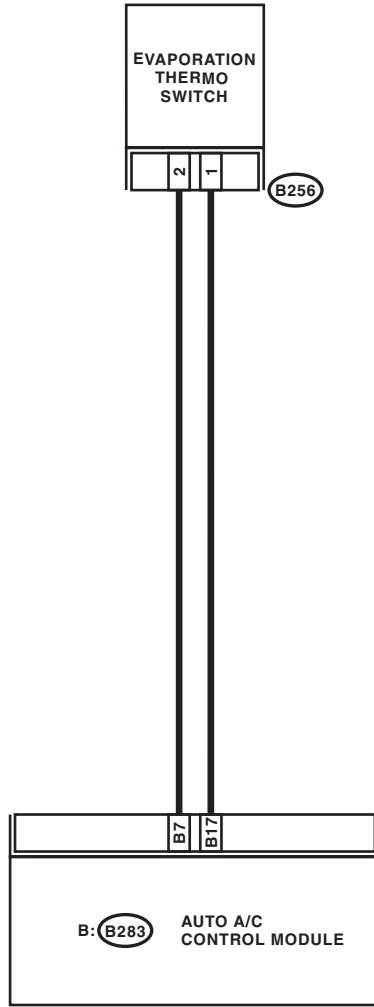

(B256)

1 2

B: (B283)

1	2	3	4	5	6	7	8	9	10
11	12	13	14	15	16	17	18	19	20

AC-01152

Diagnostic Procedure for Sensors

HVAC SYSTEM (AUTO A/C) (DIAGNOSTICS)

Step	Check	Yes	No
1 CHECK EVAPORATOR SENSOR. 1) Turn the ignition switch to OFF. 2) Remove the glove box. 3) Disconnect the connector from evaporator sensor. 4) Measure the resistance between connector terminals of evaporator sensor. <i>Terminals</i> <i>No. 1 — No. 2:</i>	Is the resistance approx. 3.3 k Ω at 20°C (68°F)?	Go to step 2.	Replace the evaporator sensor.
2 CHECK INPUT SIGNALS FOR EVAPORATOR SENSOR. 1) Turn the ignition switch to ON. 2) Measure the voltage between (B256) connector terminal and chassis ground. <i>Connector & terminal</i> <i>(B256) No. 2 (+) — Chassis ground (-):</i>	Is the voltage approx. 5 V?	Go to step 6.	Go to step 3.
3 CHECK OUTPUT SIGNALS FROM AUTO A/C CONTROL MODULE. 1) Turn the ignition switch to OFF. 2) Pull out the auto A/C control module. 3) Turn the ignition switch to ON. 4) Measure the voltage between auto A/C control module connector terminals. <i>Connector & terminal</i> <i>(B283) No. 7 (+) — No. 17 (-):</i>	Is the voltage approx. 5 V?	Go to step 4.	Go to step 6.
4 CHECK HARNESS CONNECTOR BETWEEN AUTO A/C CONTROL MODULE AND EVAPORATOR SENSOR. 1) Turn the ignition switch to OFF. 2) Disconnect the connectors from auto A/C control module. 3) Measure the resistance of harness between auto A/C control module and evaporator sensor. <i>Connector & terminal</i> <i>(B256) No. 2 — (B283) No. 7:</i>	Is the resistance less than 1 Ω ?	Go to step 5.	Repair the open circuit in harness between auto A/C control module and evaporator sensor.
5 CHECK HARNESS CONNECTOR BETWEEN AUTO A/C CONTROL MODULE AND EVAPORATOR SENSOR. Measure the resistance of harness between auto A/C control module and evaporator sensor. <i>Connector & terminal</i> <i>(B256) No. 1 — (B283) No. 17:</i>	Is the resistance less than 1 Ω ?	Go to step 6.	Repair the open circuit in harness between auto A/C control module and evaporator sensor.
6 CHECK POOR CONTACT. Check poor contact in auto A/C control module connector.	Is there poor contact in connector?	Repair the connector.	Replace the auto A/C control module.

Diagnostic Procedure for Sensors

HVAC SYSTEM (AUTO A/C) (DIAGNOSTICS)

D: SUNLOAD SENSOR

TROUBLE SYMPTOM:

- Sensor identified that sunlight is at maximum. Then, A/C system is controlled to COOL side.
- Sensor identified that sunlight is at minimum. Then, A/C system is controlled to HOT side.

NOTE:

When the sunload sensor is checked indoors or in the shade, it may be diagnosed as open circuit. Always check the sunload sensor at a place where sun shines directly on it.

WIRING DIAGRAM:

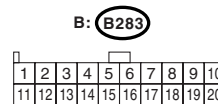
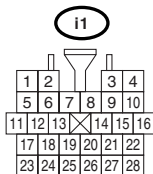
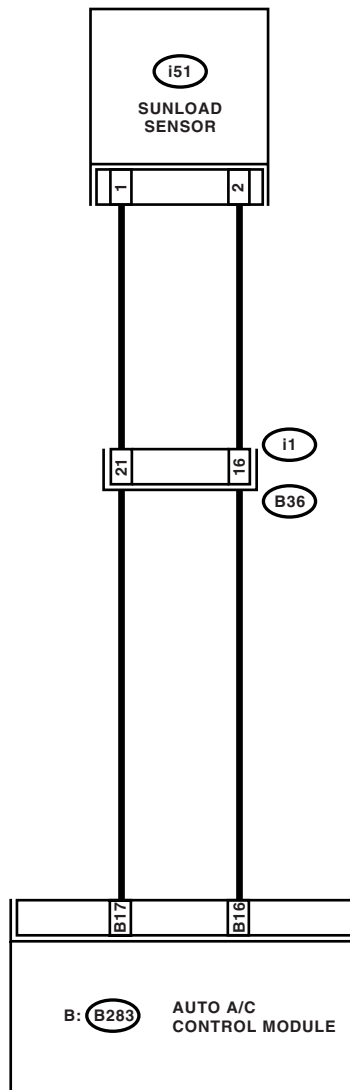

Diagnostic Procedure for Sensors

HVAC SYSTEM (AUTO A/C) (DIAGNOSTICS)

Step	Check	Yes	No
1 CHECK INPUT VOLTAGE TO SUNLOAD SENSOR. 1) Turn the ignition switch to ON. 2) Measure the input voltage to sunload sensor. <i>Connector & terminal</i> <i>(i51) No. 2 (+) — Chassis ground (-):</i>	Is the voltage approx. 5 V?	Go to step 3.	Go to step 2.
2 CHECK HARNESS CONNECTOR BETWEEN AUTO A/C CONTROL MODULE AND SUNLOAD SENSOR. 1) Turn the ignition switch to OFF. 2) Disconnect the connectors from auto A/C control module. 3) Measure the resistance of harness between auto A/C control module and sunload sensor. <i>Connector & terminal</i> <i>(i51) No. 2 — (B283) No. 16:</i>	Is the resistance less than 1 Ω ?	Go to step 3.	Repair the harness between auto A/C control module and sunload sensor.
3 CHECK HARNESS CONNECTOR BETWEEN AUTO A/C CONTROL MODULE AND SUNLOAD SENSOR. Measure the resistance of harness between auto A/C control module and sunload sensor. <i>Connector & terminal</i> <i>(i51) No. 1 — (B283) No. 17:</i>	Is the resistance less than 1 Ω ?	Go to step 4.	Repair the harness between auto A/C control module and sunload sensor.
4 CHECK THE INPUT VOLTAGE TO AUTO A/C CONTROL MODULE. 1) Connect the auto A/C control module connector. 2) Turn the ignition switch to ON. 3) Measure the voltage between auto A/C control module connector terminals. <i>Connector & terminal</i> <i>(B283) No. 16 (+) — (B283) No. 17 (-):</i>	Is the voltage approx. 2.5 V?	Go to step 5.	Replace the sunload sensor.
5 CHECK POOR CONTACT. Check poor contact in auto A/C control module connector.	Is there poor contact in connector?	Repair the connector.	Replace the auto A/C control module.

Diagnostics with Phenomenon

HVAC SYSTEM (AUTO A/C) (DIAGNOSTICS)

9. Diagnostics with Phenomenon

A: INSPECTION

Symptom	Problem parts
A/C system fails to operate.	<ul style="list-style-type: none"> • Fuse (M/B No. 5, F/B No. 17) • Connector (Poor contact) • Ground • Auto A/C control module • Blower fan motor • Blower fan relay • A/C Relay • Compressor (Magnet clutch) • Evaporator sensor
Fuse is blown out.	<ul style="list-style-type: none"> • Fuse (M/B No. 5, F/B No. 17) • Connector (Poor contact)
Illumination cannot dim.	<ul style="list-style-type: none"> • Fuse (M/B No. 5, F/B No. 17) • Connector (Poor contact) • Auto A/C control module
Blower fan does not rotate or fan speed cannot be controlled.	<ul style="list-style-type: none"> • Fuse (M/B No. 7, F/B No. 17) • Connector (Poor contact) • Ground • Auto A/C control module • Blower fan motor • Blower fan relay
Unable to switch suction vents.	<ul style="list-style-type: none"> • Connector (Poor contact) • Auto A/C control module • Intake door actuator
Unable to switch blow vents.	<ul style="list-style-type: none"> • Connector (Poor contact) • Auto A/C control module • Mode door actuator
Compartment temperature does not increase. (No hot air is discharged.)	<ul style="list-style-type: none"> • Connector (Poor contact) • Auto A/C control module • Air mix door actuator • In-vehicle sensor, ambient sensor, evaporator sensor and sunload sensor • In-vehicle sensor aspirator hose
Compartment temperature does not decrease. (No cool air is discharged.)	<ul style="list-style-type: none"> • Connector (Poor contact) • Auto A/C control module • Air mix door actuator • A/C Relay • Compressor (Magnet clutch) • Radiator fan motor • Radiator fan relay • In-vehicle sensor, ambient sensor, evaporator sensor and sunload sensor • In-vehicle sensor aspirator hose
Compartment temperature is higher or lower than setting temperature.	<ul style="list-style-type: none"> • Auto A/C control module • Air mix door actuator • In-vehicle sensor, ambient sensor, evaporator sensor and sunload sensor • In-vehicle sensor aspirator hose
Compartment temperature does not quickly respond to setting temperature.	<ul style="list-style-type: none"> • Air mix door actuator • In-vehicle sensor, ambient sensor, evaporator sensor and sunload sensor • In-vehicle sensor aspirator hose
Radiator fan does not rotate during A/C operation.	<ul style="list-style-type: none"> • Radiator fan motor • Radiator fan relay